

STEPPER MOTOR DRIVER

■ GENERAL DESCRIPTION

The NJM2673 is a stepper motor driver, which consists of a LS-TTL compatible logic input stage, off time control circuits and a pair of high power H-bridges and protection diodes.

The output current is up to 1000mA.

The NJM2673 with small number of external components conforms a complete control and drive unit for stepper motor systems.

■ PACKAGE OUTLINE

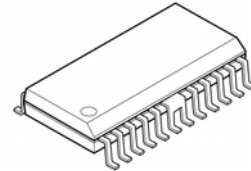

NJM2673E3
(SOP24)

■ FEATURES

- Switched mode bipolar constant current drive
- Wide voltage range 4 to 45V
- Wide range of current control 5 to 1000mA
- Half- step and full-step operation
- Thermal overload protection
- Package SOP24 JEDEC 300mil (batwing)

■ PIN CONNECTION

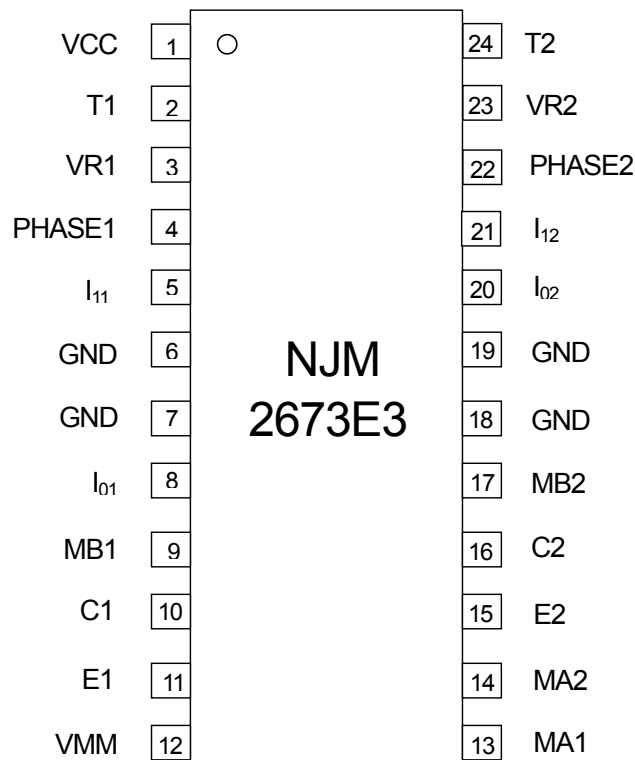

Figure1. Pin configuration

NJM2673

■ BLOCK DIAGRAM

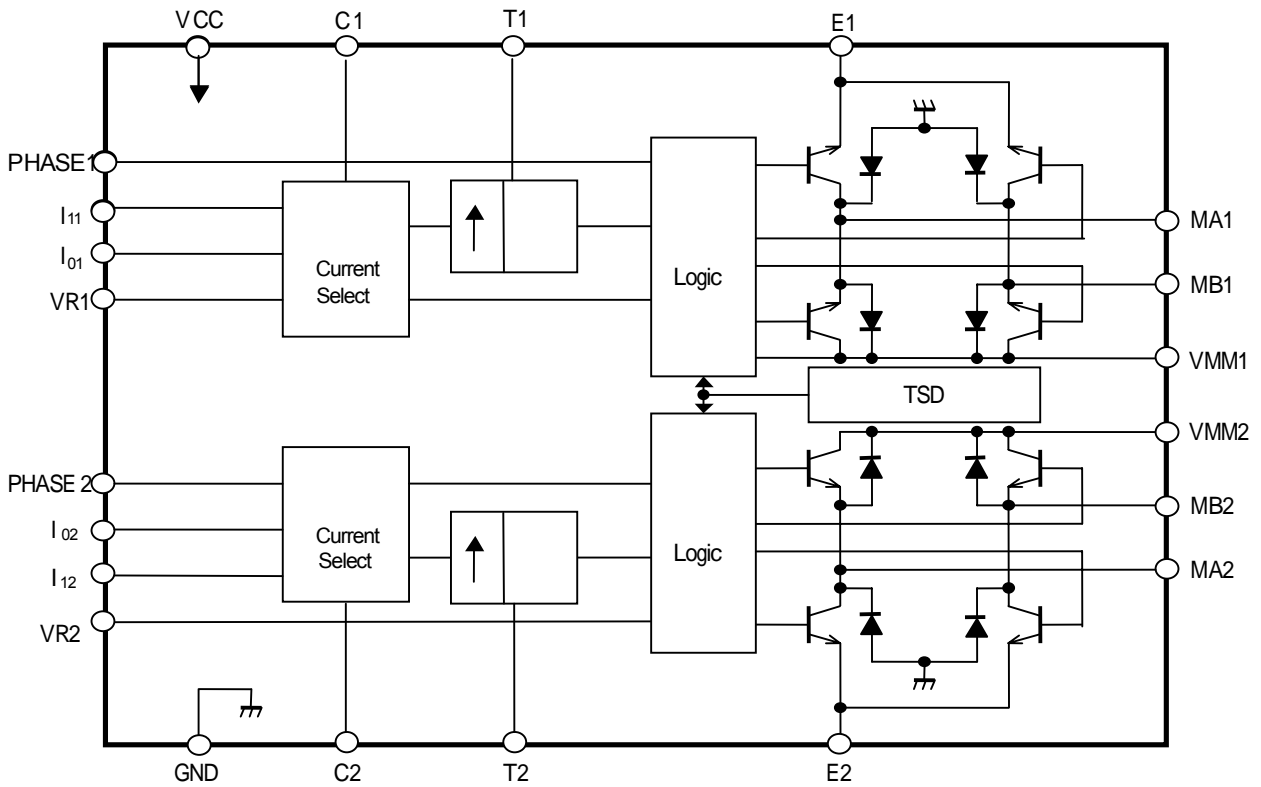

Figure 2. Block Diagram

■ PIN DESCRIPTION

SOP	Symbol	Description
1	V _{CC}	Logic voltage supply normally +5V.
2	T1	Clock Oscillator, channel 1. Timing pin connect a 56kΩ resistance and a 820pF in parallel between T and ground.
3	VR1	Reference voltage, channel 1. Controls the threshold voltage for the comparator and hence the output current.
4	PHASE1	Controls the direction of the motor current of MA1 and MB1 outputs. Motor current flows from MA1 to MB1 when Phase1 is HIGH.
5	I ₁₁	Logic input, channel 1. It controls, together with the I ₀₁ input, the current level in the output stage.
6,7,18,19	GND	Ground and negative supply. These pins are used for heat sinking. Make sure that all ground pins are soldered onto a suitable large copper ground plane for efficient heat sinking.
8	I ₀₁	Logic input, channel 1. It controls, together with the I ₁₁ input, the current level in the output stage.
9	MB1	Motor output B, channel 2. Motor current flows from MA1 to MB1 when Phase1 is high.
10	C1	Comparator input, channel 1. This input senses the instantaneous voltage across the sensing resistor, filtered through a RC network.
11	E1	Common emitter, channel 1. Connect the Sense resistor between this pin and ground.
12	VMM	Motor output A, channel 1. Motor current flows from MA1 to MB1 when Phase1 is high.
13	MA1	Motor output A, channel 2. Motor current flows from MA2 to MB2 when Phase2 is high.
14	MA2	Common emitter, channel 2. Connect the Sense resistor between this pin and ground.
15	E2	Comparator input, channel 2. This input senses the instantaneous voltage across the sensing resistor, filtered through a RC network.
16	C2	Motor output B, channel 2. Motor current flows from MA2 to MB2 when Phase2 is high.
17	MB2	Logic input, channel 2. It controls, together with the I ₁₂ input, the current level in the output stage.
20	I ₀₂	Logic input, channel 2. It controls, together with the I ₀₂ input, the current level in the output stage.
21	I ₁₂	Controls the direction of the motor current of MA2 and MB2 outputs. Motor current flows from MA2 to MB2 when Phase2 is HIGH.
22	PHASE2	Reference voltage, channel 2. Controls the threshold voltage for the comparator and hence the output current.
23	VR2	Clock Oscillator, channel 2. Timing pin connect a 56kΩ resistance and a 820pF in parallel between T and ground.
24	T2	

■ ABSOLUTE MAXIMUM RATINGS

(Ta=25°C)

NJM2673

PARAMETER	SYMBOL	MIN.	MAX.	UNIT
Voltage				
Logic Supply	V_{CC}	0	7	V
Motor Supply	V_{MM}	0	45	V
Logic Input Voltage	V_I	-0.3	V_{CC}	V
Comparator Input Voltage	V_C	-0.3	V_{CC}	V
Reference Input Voltage	V_C	-0.3	V_{CC}	V
Current				
Motor Output Current	I_M	-1000	+1000	mA
Logic Input Current	I_I	-10	-	mA
Analog Input Current	I_A	-10	-	mA
Temperature				
Operating Temperature	T_{opr}	-40	85	°C
Storage Temperature	T_{stg}	-55	150	°C

■ RECOMMENDED OPERATING CONDITIONS

PARAMETER	SYMBOL	MIN.	TYP.	MAX.	UNIT
Logic Supply	V_{CC}	4.75	5.00	5.25	V
Motor Supply	V_{MM}	4	-	40	V
Motor Output Current	I_M	-800	-	800	mA
Operating Junction Temperature	T_J	-20	-	+125	°C
Rise time Logic Inputs	t_r	-	-	2	μS
Fall Time Logic Inputs	t_f	-	-	2	μS

■ **ERECTRICAL CHARACTERISTICS** ($T_J=+25^{\circ}\text{C}$, $V_{CC}=5\text{V}$, $V_{MM}=40\text{V}$, $C_T=820\text{pF}$, $R_T=56\text{k}\Omega$)

PARAMETER	SYMBOL	CONDITION	MIN.	TYP.	MAX.	UNIT
General						
Supply Current	I_{CC}		-	-	60	mA
Turn Off	t_d	$dV_c/dt \geq 50\text{mV}/\mu\text{s}$	-	0.9	-	μs
Thermal Shutdown Temperature	TSD		-	170	-	$^{\circ}\text{C}$
Logic Input						
H Level Input Voltage	V_{IH}		2.0	-	-	V
L Level Input Voltage	V_{IL}		-	-	0.8	V
H Level Input Current	I_{IH}	$V_i=2.4\text{V}$	-	-	20	μA
L Level Input Current	I_{IL}	$V_i=0.4\text{V}$	-250	-	-	μA
Input Resistance						
Input Resistance	R_R		-	8.8	-	$\text{k}\Omega$
Analog Input						
Threshold Voltage	V_{CH}	$V_R=5.0\text{V}, I_0=I_1=L$	405	450	495	mV
	V_{CM}	$V_R=5.0\text{V}, I_0=H, I_1=L$	284	315	347	mV
	V_{CL}	$V_R=5.0\text{V}, I_0=L, I_1=H$	134	150	163	mV
Input Current	I_C		-20	-	-	μA
Motor Output						
Lower Transistor Saturation Voltage	V_{OL}	$I_M=500\text{mA}$	-	1.1	1.4	V
		$I_M=800\text{mA}$	-	1.3	1.7	V
Upper Transistor Saturation Voltage	V_{OU}	$I_M=500\text{mA}$	-	1.1	1.4	V
		$I_M=800\text{mA}$	-	1.3	1.7	V
Lower Diode Forward Voltage Drop	V_{fL}	$I_M=500\text{mA}$	-	1.0	1.3	V
		$I_M=800\text{mA}$	-	1.2	1.6	V
Upper Diode Forward Voltage Drop	V_{fU}	$I_M=500\text{mA}$	-	1.1	1.4	V
		$I_M=800\text{mA}$	-	1.3	1.7	V
Output Leak Current	I_{fL}	$I_0=I_1=H$	-	-	100	μA
Monostable						
Cut Off Time	t_{off}		-	31	-	μs

■ **THERMAL CHARACTERISTICS**

PARAMETER	SYMBOL	CONDITION	MIN.	TYP.	MAX.	UNIT
Thermal Resistance	$R_{th_{J-GND}}$		-	13	-	$^{\circ}\text{C}$
	$R_{th_{J-A}}$	Note2	-	42	-	$^{\circ}\text{C}$

Notes

1. All voltages are with respect to ground. Currents are positive into, negative out of specified terminal.
2. All ground pins soldered onto 20cm^2 PCB copper area with free air condition, $T_A=25^{\circ}\text{C}$.

NJM2673

■ TYPICAL APPLICATION CIRCUIT

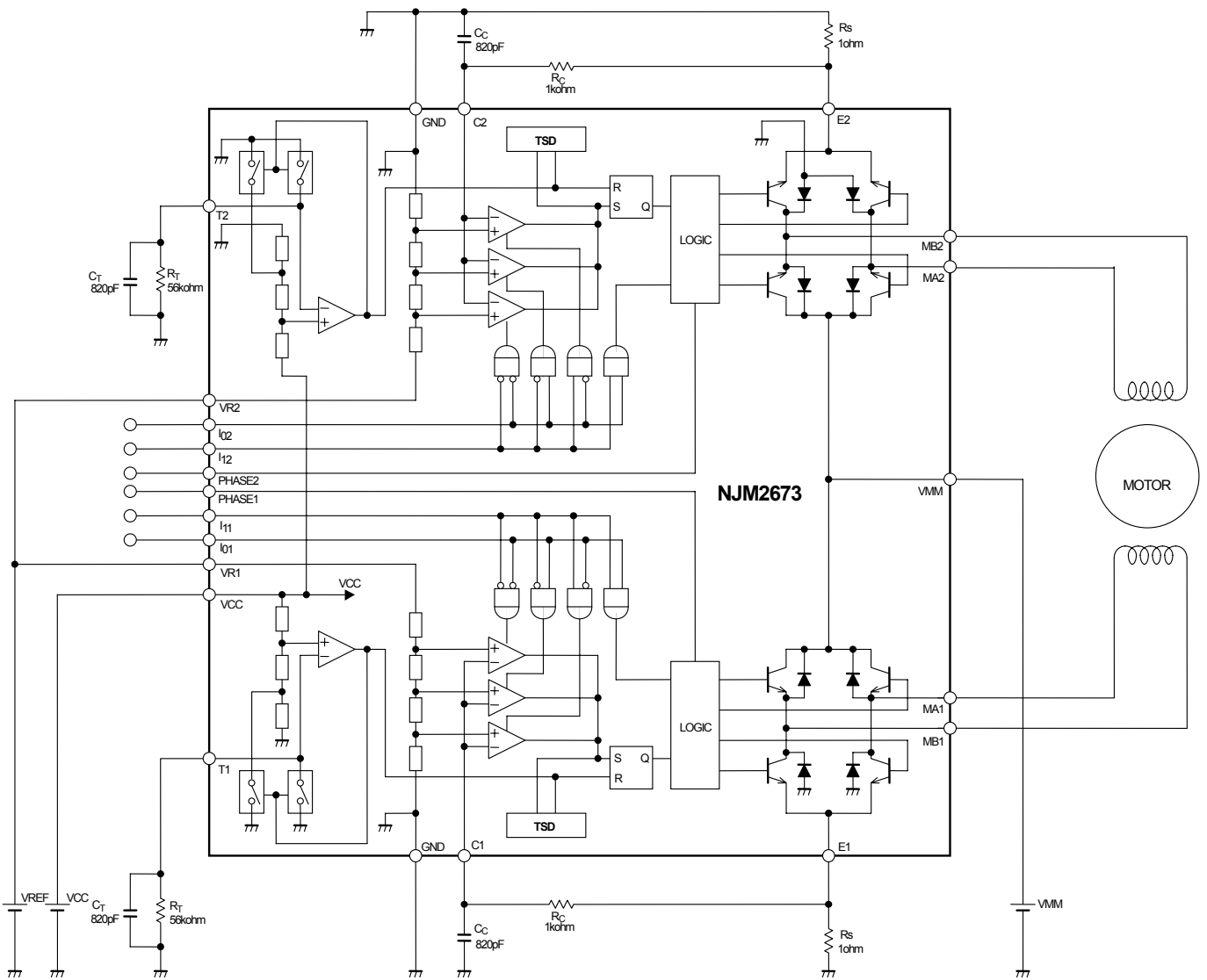
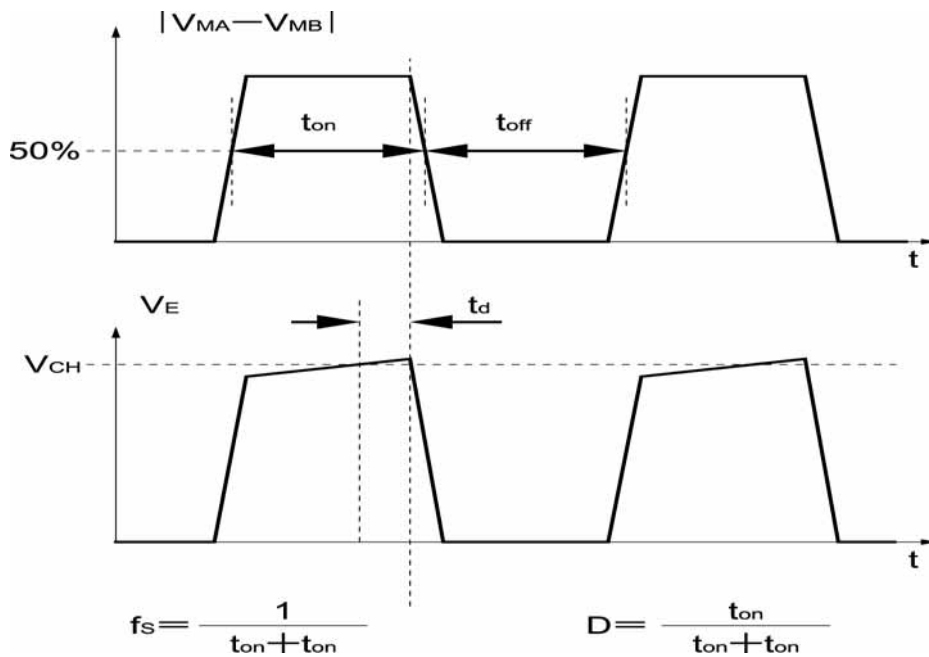

Figure 3. Application Circuit

■ TYPICAL APPLICATION CIRCUIT



New Japan Radio Co., Ltd.

FUNCTIONAL DESCRIPTION

The NJM2673 is intended to drive a bipolar constant current through one winding of a 2-phase stepper motor.

Current control is achieved through switched-mode regulation, see figure 4 and 5.

Three different current levels and zero current can be selected by the input logic.

The circuit contains the following functional blocks:

- Input logic
- Current sense
- Single-pulse generator
- Output stage

Input logic

Phase input

The phase input determines the direction of the current in the motor winding. High input forces the current from terminal M_A to M_B and low input from terminal M_B to M_A . A Schmitt trigger provides noise immunity and a delay circuit eliminates the risk of cross conduction in the output stage during a phase shift.

Half- and full-step operation is possible.

Current level selection.

The status of I_0 and I_1 inputs determines the current level in the motor winding. Three fixed current levels can be selected according to the table below.

Motor current		I_0	I_1
High level	100%	L	L
Medium level	60%	H	L
Low level	20%	L	H
Zero current	0%	H	H

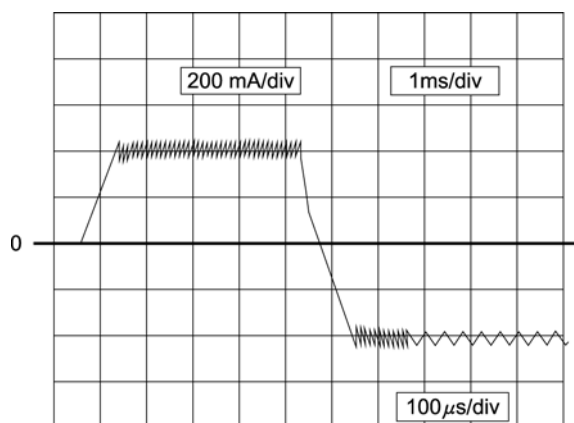

Figure 4. Motor current (I_M),
Vertical : 200 mA/div,
Horizontal: 1 ms/div,
expanded part 100 μ s/div.

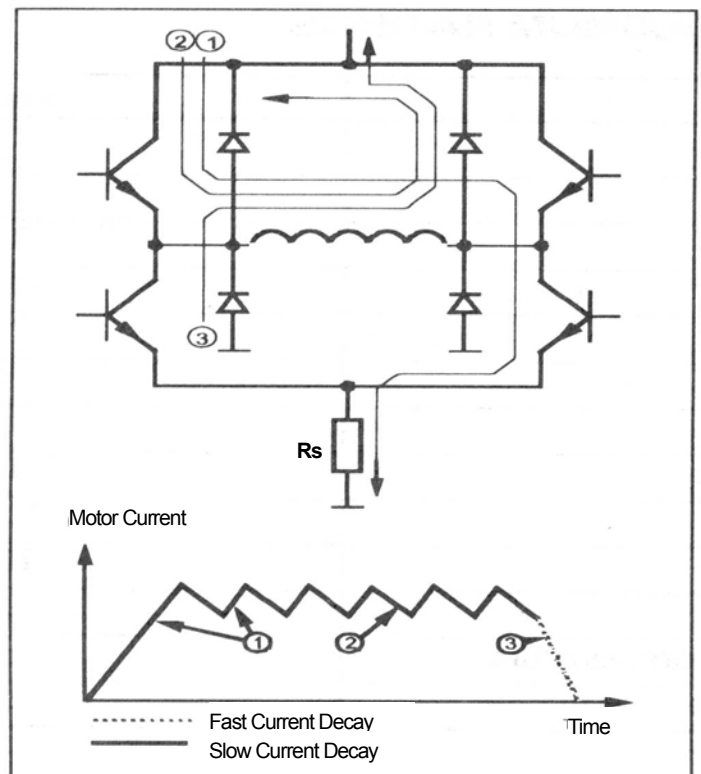

Figure 5. Output stage with current paths for fast and slow current decay.

The specific values of the different current levels are determined by the reference voltage V_R together with the value of the sensing resistor R_S .

The peak motor current can be calculated as follows:

$$i_m = (V_R \cdot 0.080) / R_S \text{ [A], at 100% level}$$

$$i_m = (V_R \cdot 0.050) / R_S \text{ [A], at 60% level}$$

$$i_m = (V_R \cdot 0.016) / R_S \text{ [A], at 20% level}$$

The motor current can also be continuously varied by modulating the voltage reference input.

Current sensor

The current sensor contains a reference voltage divider and three comparators for measuring each of the selectable current levels. The motor current is sensed as a voltage drop across the current sensing resistor, R_S , and compared with one of the voltage references from the divider. When the two voltages are equal, the comparator triggers the single-pulse generator. Only one comparator at a time is activated by the input logic.

Single-pulse generator

The pulse generator is a monostable multivibrator triggered on the positive edge of the comparator output. The multivibrator output is high during the pulse time, t_{off} , which is determined by the timing components R_T and C_T .

The single pulse switches off the power feed to the motor winding, causing the winding to decrease during t_{off} .

If a new trigger signal should occur during t_{off} , it is ignored.

Output stage

The output stage contains four transistors and four diodes, connected in an H-bridge. Note that the upper recirculation diodes are connected to the circuit externally. The two sinking transistors are used to switch the power supplied to the motor winding, thus driving a constant current through the winding. See figures 4 and 5.

Overload protection

The circuit is equipped with a thermal shut-down function, which will limit the junction temperature. The output current will be reduced if the maximum permissible junction temperature is exceeded. It should be noted, however, that it is not short circuit protected.

Operation

When a voltage V_{MM} is applied across the motor winding, the current rise follows the equation:

$$i_m = (V_{MM} / R) \cdot (1 - e^{-(R \cdot t) / L})$$

R = Winding resistance

L = Winding inductance

t = time

(see figure 5, arrow 1)

The motor current appears across the external sensing resistor, R_S , as an analog voltage. This voltage is fed through a low-pass filter, $R_C C_C$, to the voltage comparator input (pin 10 and pin 16). At the moment the sensed voltage rises above the comparator threshold voltage, the monostable is triggered and its output turns off the conducting sink transistor. The polarity across the motor winding reverses and the current is forced to circulate through the appropriate upper protection diode back through the source transistor (see figure 5, arrow 2).

After the monostable has timed out, the current has decayed and the analog voltage across the sensing resistor is below the comparator threshold level. The sinking transistor then turns on and the motor current starts to increase again. The cycle is repeated until the current is turned off via the logic inputs. When both I_1 and I_0 are high, all four transistors in the output H-bridge are turned off, which means that inductive current recirculates through two opposite free-wheeling diodes (see figure 5, arrow 3). This method of turning off the current results in a faster current decay than if only one transistor was turned off and will therefore improve speed performance in half-stepping mode.

■ PRINCIPAL OPERATING SEQUENCE

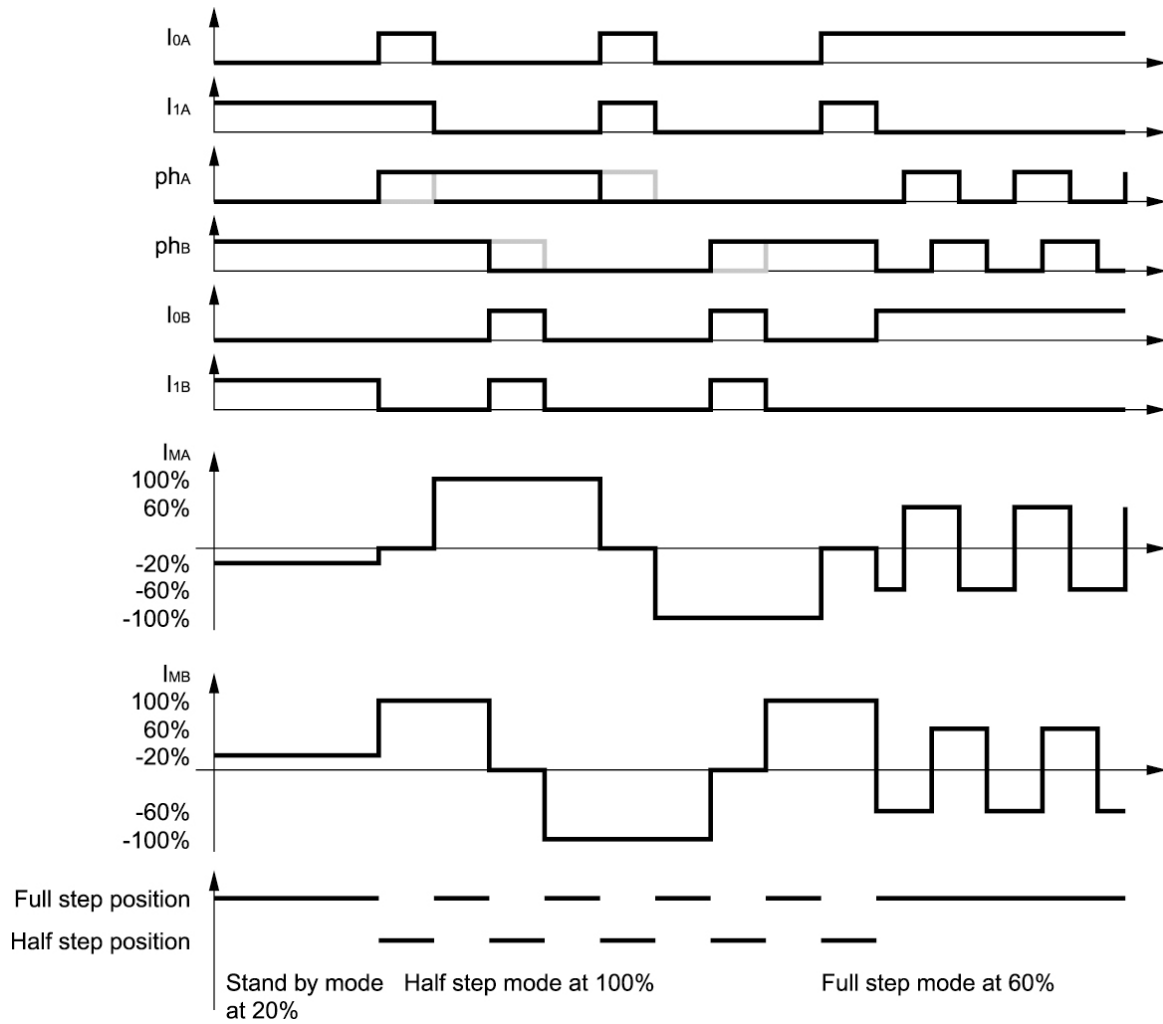

■ APPLICATIONS INFORMATION

Motor selection

Some stepper motors are not designed for continuous operation at maximum current. As the circuit drives a constant current through the motor, its temperature can increase, both at low- and high-speed operation.

Some stepper motors have such high core losses that they are not suited for switched-mode operation.

Interference

As the circuit operates with switched-mode current regulation, interference-generation problems can arise in some applications. A good measure is then to decouple the circuit with a 0.1 μF ceramic capacitor, located near the package across the power line VMM and ground.

Also make sure that the V_{Ref} input is sufficiently decoupled. An electrolytic capacitor should be used in the +5V rail, close to the circuit.

The ground leads between R_S , C_C and circuit GND should be kept as short as possible. This applies also to the leads connecting R_S and R_C to pin 10 and pin 11, pin 15 and pin 16 respectively.

In order to minimize electromagnetic interference, it is recommended to route M_A and M_B leads in parallel on the printed circuit board directly to the terminal connector. The motor wires should be twisted in pairs, each phase separately, when installing the motor system.

Unused inputs

Unused inputs should be connected to proper voltage levels in order to obtain the highest possible noise immunity.

Ramping

A stepper motor is a synchronous motor and does not change its speed due to load variations. This means that the torque of the motor must be large enough to match the combined inertia of the motor and load for all operation modes. At speed changes, the required torque increases by the square, and the required power by the cube of the speed change. Ramping, i.e., controlled acceleration or deceleration must then be considered to avoid motor pullout.

VCC , VMM

The supply voltages, VCC and VMM, can be turned on or off in any order. Normal dv/dt values are assumed.

Before a driver circuit board is removed from its system, all supply voltages must be turned off to avoid destructive transients being generated by the motor.

Switching frequency

The motor inductance, together with the pulse time, t_{off} , determines the switching frequency of the current regulator. The choice of motor may then require other values on the R_T , C_T components than those recommended in figure 3, to obtain a switching frequency above the audible range. Switching frequencies above 40 kHz are not recommended because the current regulation can be affected.

Analog control

As the current levels can be continuously controlled by modulating the V_R input, limited microstepping can be achieved.

Sensor resistor

The R_S resistor should be of a noninductive type power resistor. A 1.0 ohm resistor, tolerance $\leq 1\%$, is a good choice for 415 mA max motor current at $V_R = 5\text{V}$.

The peak motor current, i_m , can be calculated by using the formula:

$$i_m = (V_R \cdot 0.080) / R_S \text{ [A], at 100\% level}$$

■ TYPICAL CHARACTERISTICS

VCC VS. ICC
@NJM2673 I0=I1=LOW

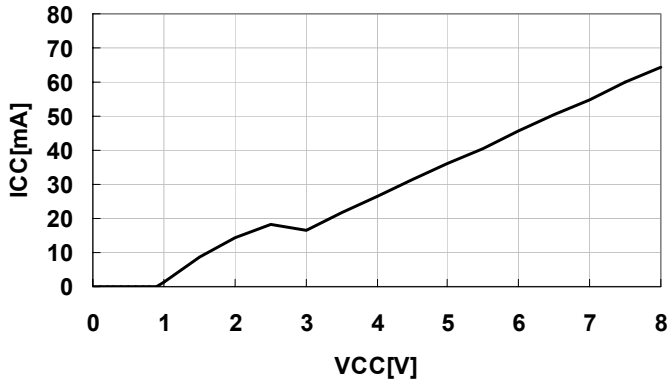

VCC VS. ICC
@NJM2673 I0=I1=HIGH

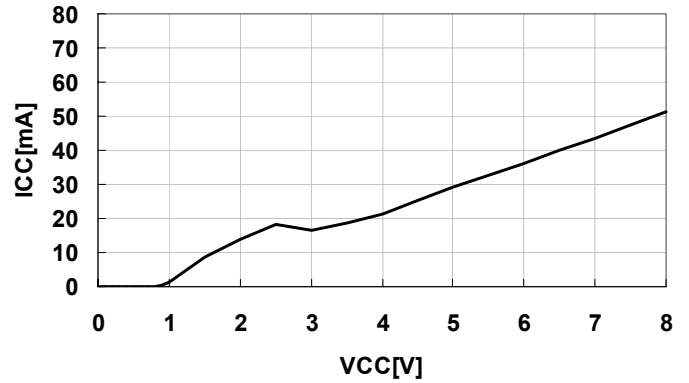

COMP input Voltage VS. COMP input Current
@NJM2673 VCC=VR=5V I0=I1=LOW

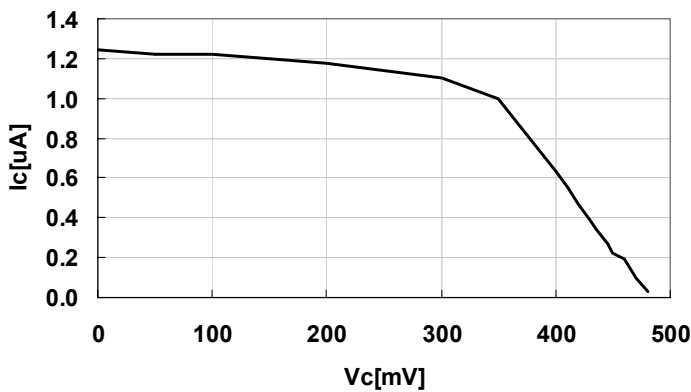

COMP input Voltage VS. COMP input Current
@NJM2673 VCC=VR=5V I0=LOW I1=HIGH

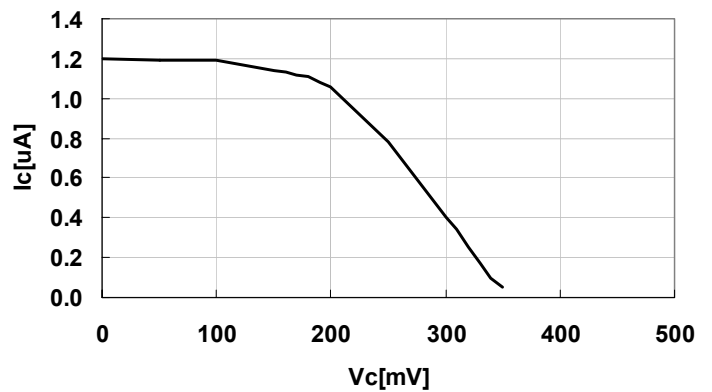

COMP input Voltage VS. COMP input Current
@NJM2673 VCC=VR=5V I0=HIGH I1=LOW

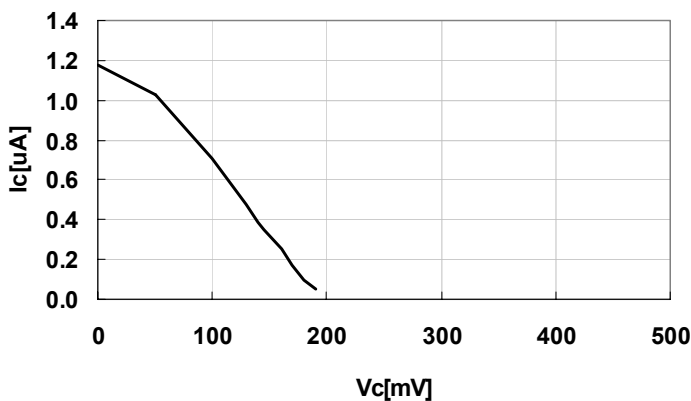

Phase input Voltage VS. Phase input Current
@NJM2673 VCC=VR=5V

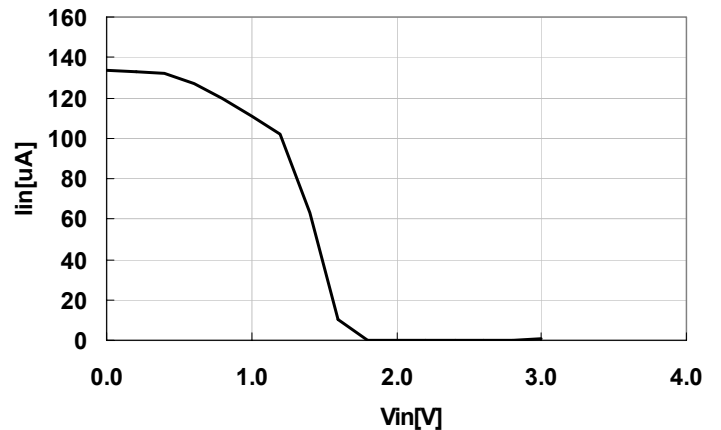

■ TYPICAL CHARACTERISTICS

Power Dissipation vs Motor Current
NJM2673(1ch Drive)VCC=5V, VMM=40V, ta=25°C

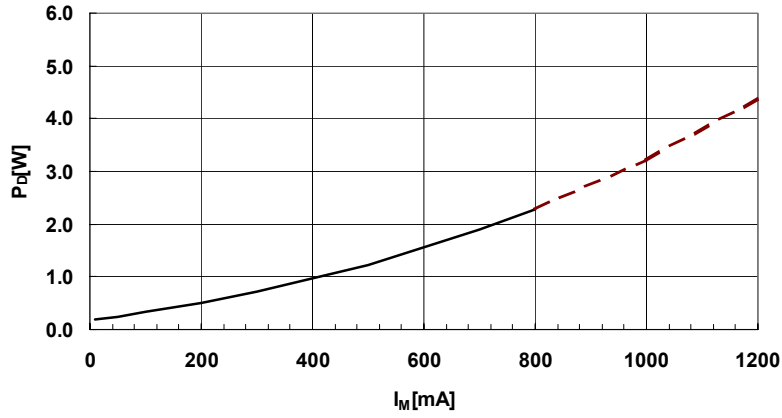

Power Dissipation vs Motor Current
NJM2673(2ch Drive)VCC=5V, VMM=40V, ta=25°C

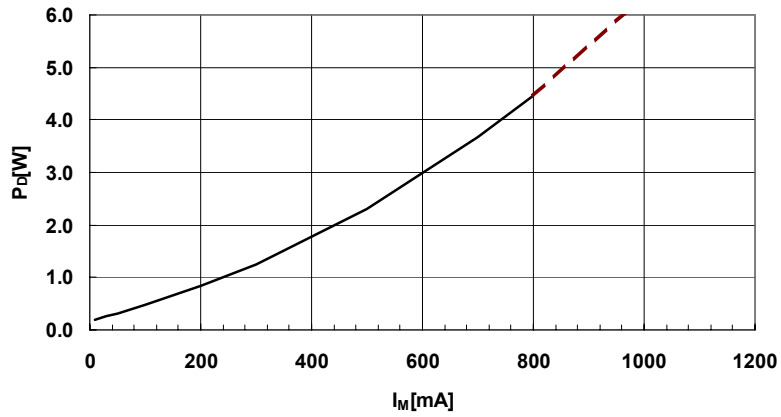

[CAUTION]

The specifications on this databook are only given for information, without any guarantee as regards either mistakes or omissions. The application circuits in this databook are described only to show representative usages of the product and not intended for the guarantee or permission of any right including the industrial rights.

Mouser Electronics

Authorized Distributor

Click to View Pricing, Inventory, Delivery & Lifecycle Information:

[NJR:](#)

[NJM2673E3-TE2](#) [NJM2673E3](#)

Компания «Life Electronics» занимается поставками электронных компонентов импортного и отечественного производства от производителей и со складов крупных дистрибьюторов Европы, Америки и Азии.

С конца 2013 года компания активно расширяет линейку поставок компонентов по направлению коаксиальный кабель, кварцевые генераторы и конденсаторы (керамические, пленочные, электролитические), за счёт заключения дистрибьюторских договоров

Мы предлагаем:

- Конкурентоспособные цены и скидки постоянным клиентам.
- Специальные условия для постоянных клиентов.
- Подбор аналогов.
- Поставку компонентов в любых объемах, удовлетворяющих вашим потребностям.
- Приемлемые сроки поставки, возможна ускоренная поставка.
- Доставку товара в любую точку России и стран СНГ.
- Комплексную поставку.
- Работу по проектам и поставку образцов.
- Формирование склада под заказчика.
- Сертификаты соответствия на поставляемую продукцию (по желанию клиента).
- Тестирование поставляемой продукции.
- Поставку компонентов, требующих военную и космическую приемку.
- Входной контроль качества.
- Наличие сертификата ISO.

В составе нашей компании организован Конструкторский отдел, призванный помогать разработчикам, и инженерам.

Конструкторский отдел помогает осуществить:

- Регистрацию проекта у производителя компонентов.
- Техническую поддержку проекта.
- Защиту от снятия компонента с производства.
- Оценку стоимости проекта по компонентам.
- Изготовление тестовой платы монтаж и пусконаладочные работы.



Тел: +7 (812) 336 43 04 (многоканальный)

Email: org@lifeelectronics.ru