



General Description

The SLG59M1804V is designed for load switching application. The part comes with two 4.5 A rated MOSFETs switched on by two ON control pins. Each MOSFETs turn on time is independently adjusted by an external capacitor.

Features

- UL2367 Certified - File Number E497808
- Two 4.5A independent MOSFETs
- Two Integrated VGS Charge Pumps
- Two internal discharges per channel for gate and source
- Independent Ramp Control
- Protected by thermal shutdown with current limit
- Pb-Free / RoHS Compliant
- Halogen-Free
- STDFN 14L, 1 x 3 x 0.55 mm

Pin Configuration

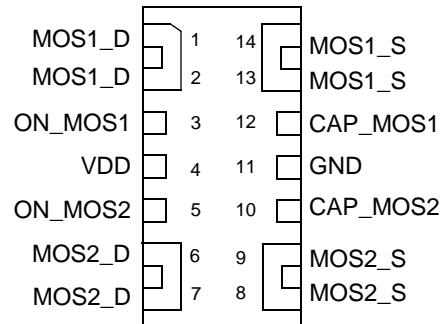

14-pin STDFN
(Top View)

Applications

- Ideal for switching ON and OFF S0 +5.0 and 3.3V power rails with associated support circuitry discharges.
- Ideal for switching ON and OFF power rails 5V or less.
- Can use either channel up to 4.5A with combined maximum current of 8.5A
- Maximum load capacitance of 1000 μ F for each Channel Source terminal.

Block Diagram

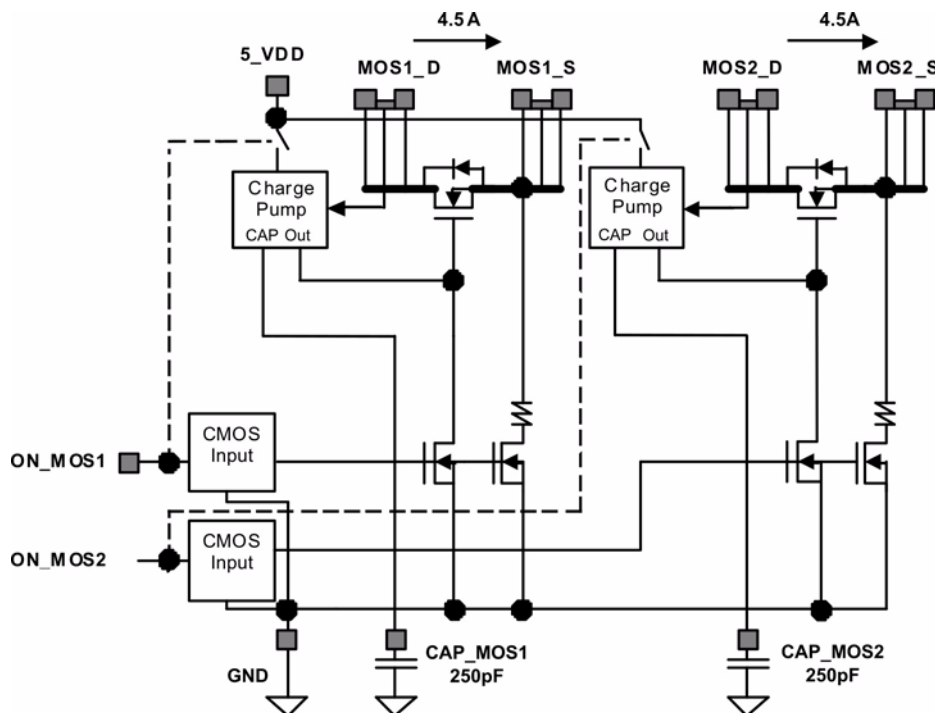

Do not probe CAP_MOS1 (PIN 12) or CAP_MOS2 (PIN 10) with low impedance probe.



Pin Description

Pin #	Pin Name	Type	Pin Description
1	MOS1_D	MOSFET	Drain of MOSFET1
2	MOS1_D	MOSFET	Drain of MOSFET1 (fused with pin 1)
3	ON_MOS1	Input	Turns on MOS1 (4 M Ω pull down resistor)
4	VDD	VDD	+5VDD Power
5	ON_MOS2	Input	Turns on MOS2 (4 M Ω pull down resistor)
6	MOS2_D	MOSFET	Drain of MOSFET2
7	MOS2_D	MOSFET	Drain of MOSFET2 (fused with pin 6)
8	MOS2_S	MOSFET	Source of MOSFET2 (fused with pin 9)
9	MOS2_S	MOSFET	Source of MOSFET2
10	CAP_MOS2	Input	Sets ramp and turn on time for MOSFET2
11	GND	GND	Ground
12	CAP_MOS1	Input	Sets ramp and turn on time for MOSFET1
13	MOS1_S	MOSFET	Source of MOSFET1 (fused with pin 14)
14	MOS1_S	MOSFET	Source of MOSFET1

Ordering Information

Part Number	Type	Production Flow
SLG59M1804V	STDFN 14L	Industrial, -40 °C to 85 °C
SLG59M1804VTR	STDFN 14L (Tape and Reel)	Industrial, -40 °C to 85 °C



Absolute Maximum Ratings

Parameter	Description	Conditions	Min.	Typ.	Max.	Unit
V_D	Power Supply		--	--	6	V
T_S	Storage Temperature		-65	--	150	°C
ESD_{HBM}	ESD Protection	Human Body Model	2000	--	--	V
W_{DIS}	Package Power Dissipation		--	--	1.2	W
$ID_{S_{MAX}}$	Max Operating Current				4.5	A
MOSFET $ID_{S_{PK}}$	Peak Current from Drain to Source	Maximum pulsed switch current, pulse width < 1 ms, 1% duty cycle	--	--	8	A

Note: Stresses greater than those listed under "Absolute Maximum Ratings" may cause permanent damage to the device. This is a stress rating only and functional operation of the device at these or any other conditions above those indicated in the operational sections of this specification is not implied. Exposure to absolute maximum rating conditions for extended periods may affect reliability.

Electrical Characteristics

$T_A = -40\text{ °C to }85\text{ °C}$ (unless otherwise stated)

Parameter	Description	Conditions	Min.	Typ.	Max.	Unit
V_{DD}	Power Supply Voltage		2.5	--	5.0	V
I_{DD}	Power Supply Current when OFF		--	0.1	1	μA
	Power Supply Current ON_MOS_1 & ON_MOS_2 (Steady State)		--	50	75	μA
$R_{DS_{ON}}$	ON Resistance	T_A 25°C MOSFET1 @100 mA	--	14.5	18	mΩ
		T_A 70°C MOSFET1 @100 mA	--	17	22	mΩ
		T_A 85°C MOSFET1 @100 mA	--	18	23	mΩ
		T_A 85°C MOSFET1 @ 4.5 A	--	19.3	25.1	mΩ
		T_A 25°C MOSFET2 @100 mA	--	14.5	18	mΩ
		T_A 70°C MOSFET2 @100 mA	--	17	22	mΩ
		T_A 85°C MOSFET2 @100 mA	--	18	23	mΩ
		T_A 85°C MOSFET2 @ 4.5 A	--	19.3	25.1	mΩ
MOSFET ID_S	Current from Drain to Source for each MOSFET	Continuous	--	--	4.5	A
V_D	Drain Voltage		0.9	--	V_{DD}	V
T_{ON_Delay}	ON pin Delay Time	50% ON to Ramp Begin	0	300	500	μs
T_{Total_ON}	Total Turn On Time	50% ON to 90% V_S	Configurable ¹			ms
		Example: CAP = 4 nF, $V_{DD} = V_D = 5\text{ V}$, Source_Cap = 10 μF, $R_L = 20\text{ Ω}$	--	2.0	--	ms
$T_{SLEWRATE}$	Slew Rate	10% V_S to 90% V_S	Configurable ¹			V/ms
		Example: CAP = 4 nF, $V_{DD} = V_D = 5\text{ V}$, Source_Cap = 10 μF, $R_L = 20\text{ Ω}$	--	3.0	--	V/ms
CAP_{SOURCE}	Source Cap	Source to GND	--	--	1000	μF
R_{DIS}	Discharge Resistance		100	150	300	Ω
ON_ V_{IH}	High Input Voltage on ON pin		0.85	--	V_{DD}	V
ON_ V_{IL}	Low Input Voltage on ON pin		-0.3	0	0.3	V
I_{LIMIT}	Active Current Limit	MOSFET will automatically limit current when $V_S > 250\text{ mV}$	--	6.0	8	A
$THERM_{ON}$	Thermal shutoff turn-on temperature		--	125	--	°C



Electrical Characteristics (continued)

$T_A = -40\text{ }^\circ\text{C}$ to $85\text{ }^\circ\text{C}$ (unless otherwise stated)

Parameter	Description	Conditions	Min.	Typ.	Max.	Unit
THERM _{OFF}	Thermal shutoff turn-off temperature		--	100	--	$^\circ\text{C}$
THERM _{TIME}	Thermal shutoff time		--	--	1	ms
T _{OFF_Delay}	OFF Delay Time	50% ON to V_S Fall, $V_{DD} = V_D = 5\text{ V}$	--	--	15	μs

Notes:

1. Refer to table for configuration details.

T_{Total_ON}, T_{ON_Delay} and Slew Rate Measurement

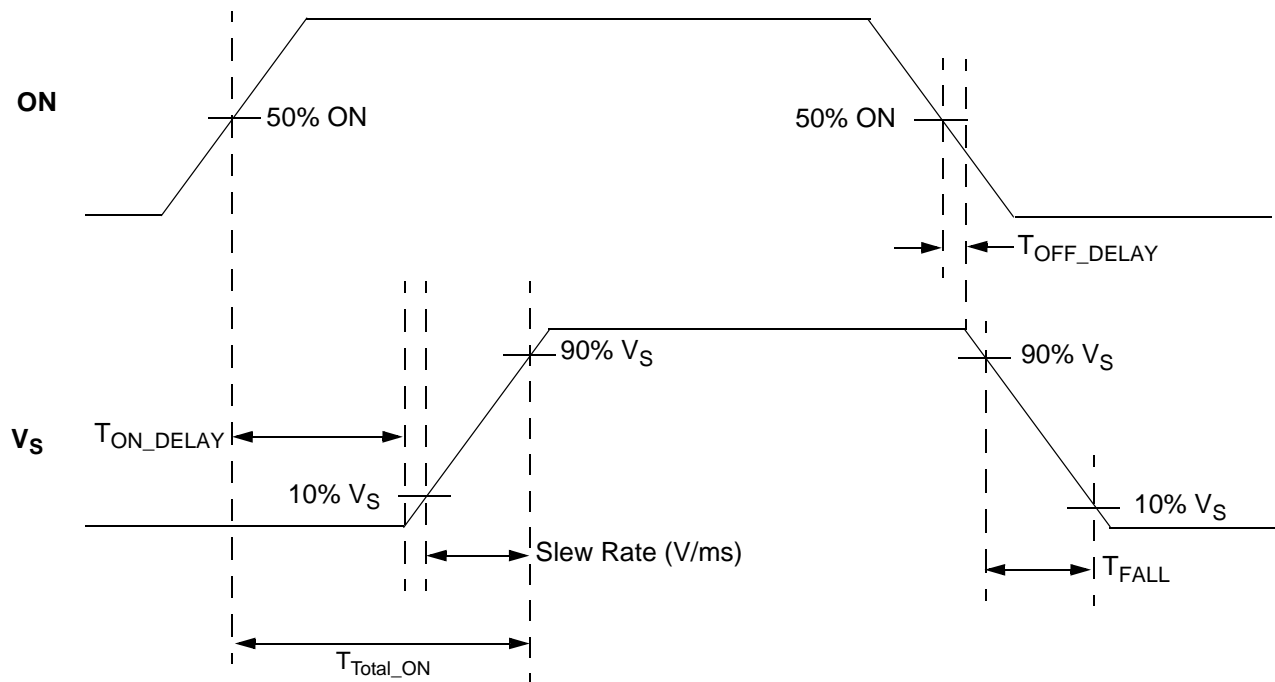



Application Notes SLG59M1804V Power-Up/Power-Down Sequence Considerations

To ensure glitch-free power-up under all conditions, apply V_{DD} first, followed by V_D after V_{DD} exceeds 1 V. Then allow V_D to reach 90% of its max value before toggling the ON pin from Low-to-High. Likewise, power-down in reverse order.

If V_{DD} and V_D need to be powered up simultaneously, glitching can be minimized by having a suitable load capacitor. A 10 μF C_{LOAD} will prevent glitches for rise times of V_{DD} and V_D less than 2 ms.

If the ON pin is toggled HIGH before V_{DD} and V_D have reached their steady-state values, the IPS timing parameters may differ from datasheet specifications.

The slew rate of output V_S follows a linear ramp set by a capacitor connected to the CAP pin. A larger capacitor value at the CAP pin produces a slower ramp, reducing inrush current from capacitive loads.

SLG59M1804V Current Limiting

The SLG59M1804V has two forms of current limiting.

Standard Current Limiting Mode

Current is measured by mirroring the current through the main MOSFET. The mirrored current is then sent through a resistor creating a voltage $V(i)$ proportional to the MOSFET current. The $V(i)$ is then compared with a Band Gap voltage $V(BG)$. If $V(i)$ exceeds the Band Gap voltage then the voltage $V(g)$ on the gate of the main MOSFET is reduced. The $V(g)$ continues to drop until $V(i) < V(BG)$. This response is a closed loop response and is therefore very fast and current limits in less than a few micro-seconds. There is no difference between peak or constant current limit.

Temperature Cutoff

However, as the $V(g)$ drops the $R_{ds}(ON)$ of the main MOSFET will increase, thus limiting the current, but also increasing the power dissipation of the IC. The IC is very small and cannot dissipate much power. Therefore, if a current limit condition is sustained the IC will heat up. If the temperature exceeds approximately 120°C, then $V(g)$ will be brought low completely shutting off the main MOSFET. As the die cools the MOSFET will be turned back on at 100°C.

If the current limiting condition has not been mitigated then the die will again heat up to 120°C and the process will repeat.

Short Circuit Current Limiting Mode

When $V(V_S) < 250$ mV, which is the case if there is a solder bridge during the manufacturing process or a hard short on the power rail, then the current is limited to approximately 500 mA. This current limit is accomplished in the same manner as the Standard Current Limiting Mode with the exception that the current mirror is 12x greater. Because the current mirror is so much larger, a 15x smaller main MOSFET current is required to generate the same $V(i)$. If $V(V_S)$ rises above approximately 250 mV, then this mode is automatically switched out.

Slew Rate Control

V_S slew rate control, or inrush current control for each channel, is set by an external capacitor on pin 10 and pin 12. The charging current drawn from V_D is commonly referred to as " V_D Inrush Current" and can cause the input power source to collapse if the V_D inrush current is too high. The expression relating V_D inrush current, V_S slew rate and C_{OUT} is:

$$V_D \text{ Inrush Current, A} = C_{OUT}, \mu\text{F} \times \text{Slew Rate, V/ms}$$

Dependence of Slew Rate from Cap on Pin 10 and pin 12 is illustrated on page 6. Since the IPS has some T_{on} Delay time before V_S starts rising, the dependence of Total ON time vs Cap on pin 10 and pin 12 can be estimated and is illustrated on page 6.



T_{SLEW} vs. CAP

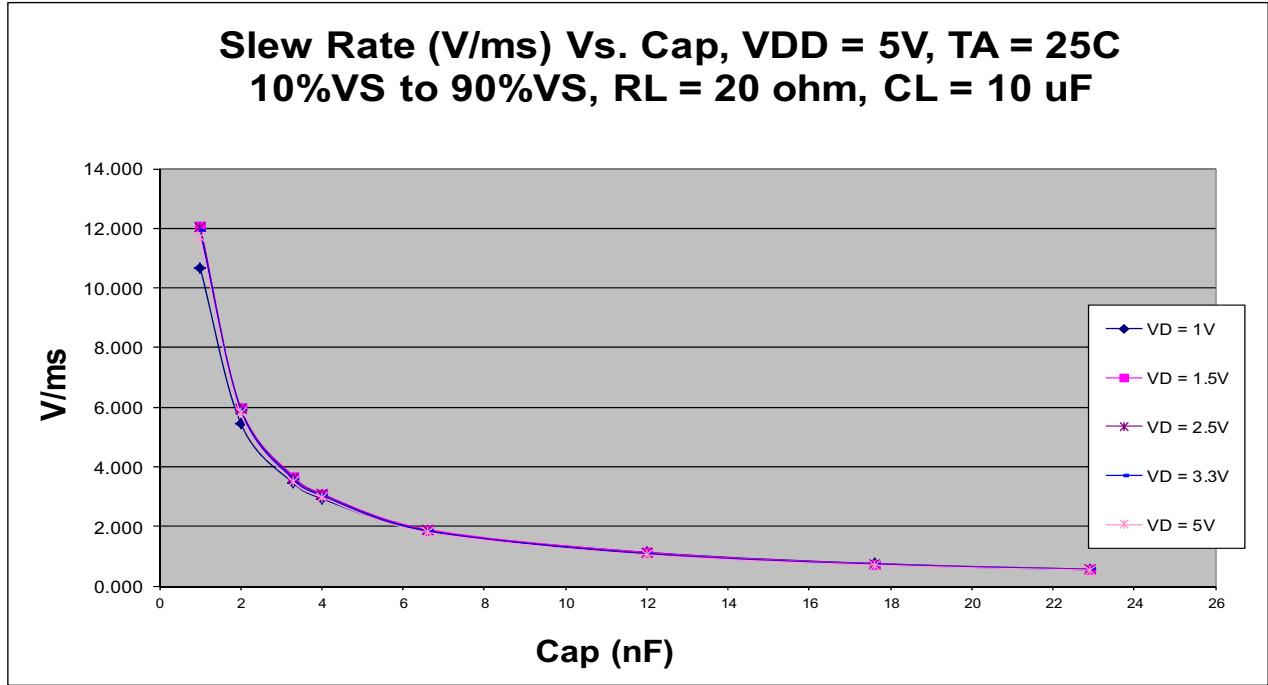

T_{TOTAL_ON} vs. CAP

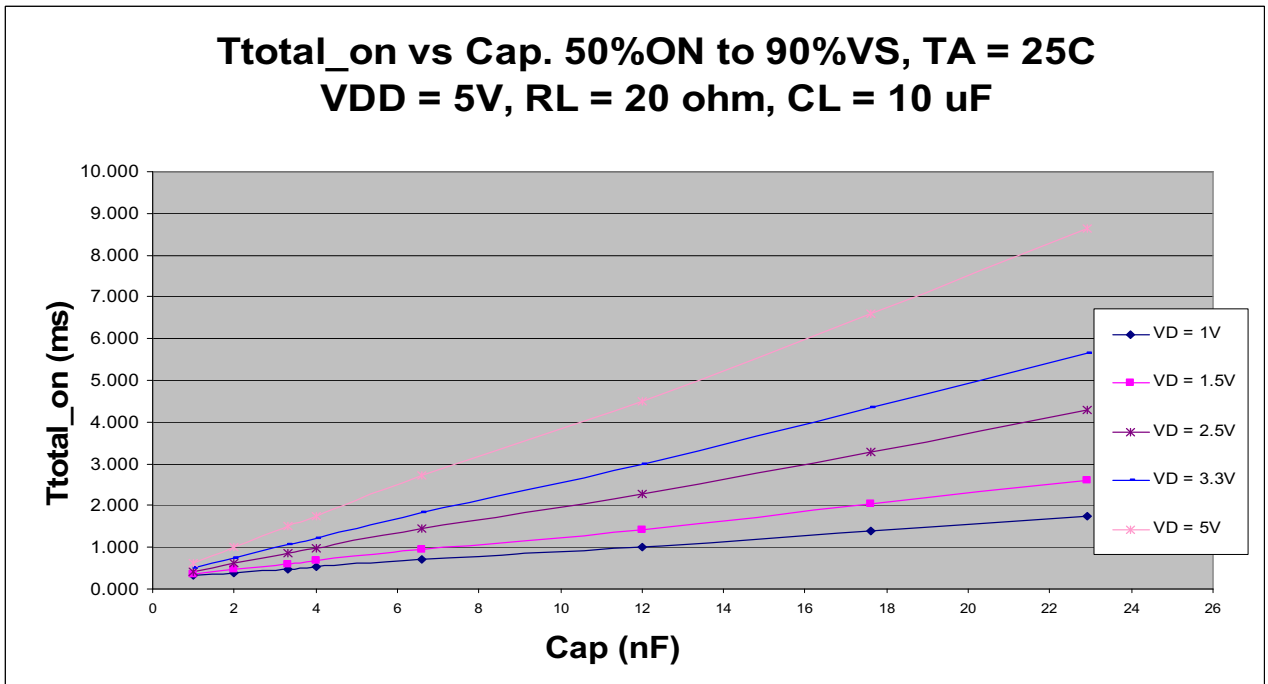



RDS_{ON} (typ) vs IDS @ T_A = 85°C

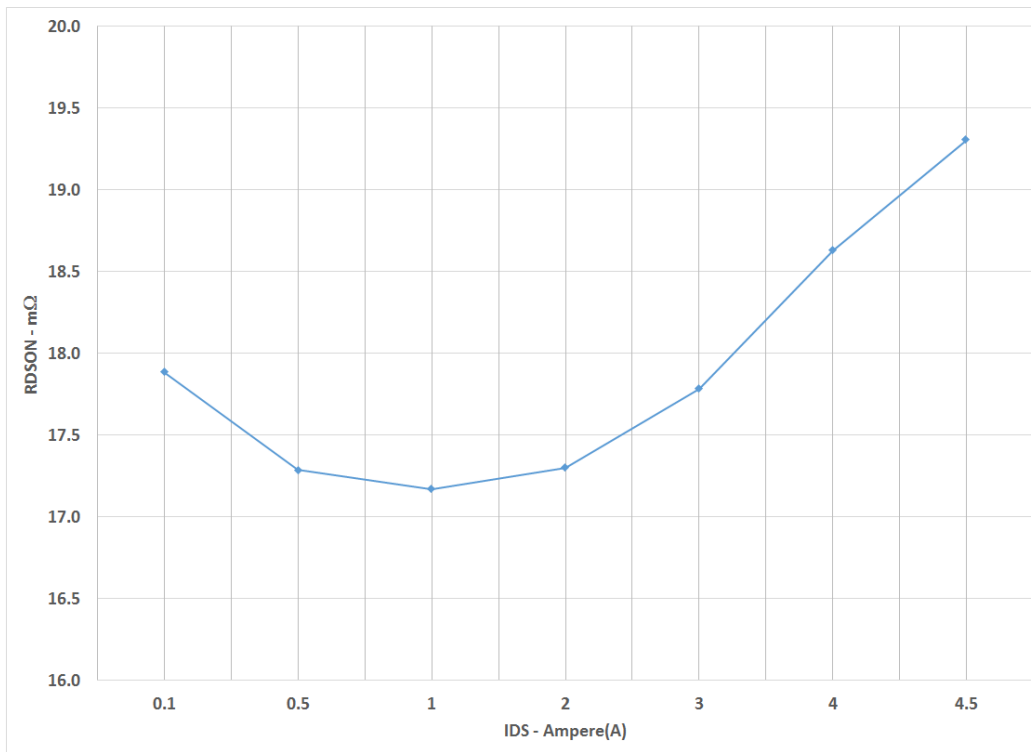



Package Top Marking System Definition



Part Number: SLG59M1804V
Production Part Code: CN



Package Drawing and Dimensions

14 Lead STDFN Package 1 mm x 3 mm (Fused Lead)

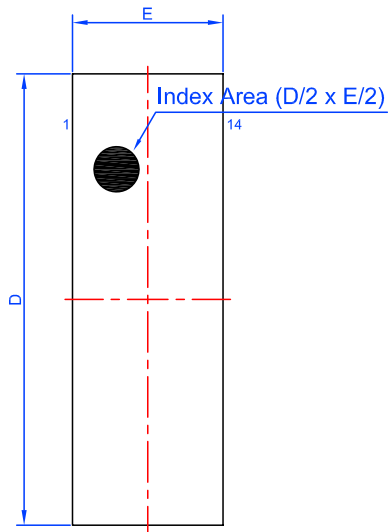

Top View

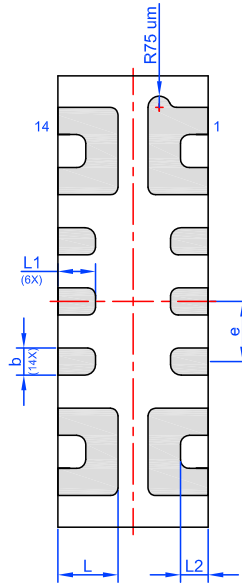

BTM View

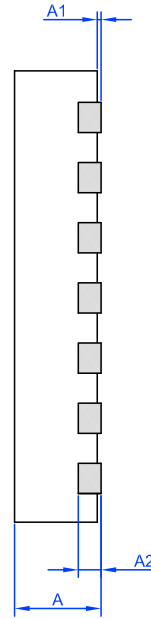

SIDE View

Unit: mm

Symbol	Min	Nom.	Max	Symbol	Min	Nom.	Max
A	0.50	0.55	0.60	D	2.95	3.00	3.05
A1	0.005	-	0.050	E	0.95	1.00	1.05
A2	0.10	0.15	0.20	L	0.35	0.40	0.45
b	0.13	0.18	0.23	L1	0.20	0.25	0.30
e	0.40 BSC			L2	0.06	0.11	0.16



Tape and Reel Specifications

Package Type	# of Pins	Nominal Package Size	Units per Reel	Max Units per Box	Reel & Hub Size (mm)	Trailer A		Leader B		Pocket Tape (mm)	
						Pockets	Length (mm)	Pockets	Length (mm)	Width	Pitch
STDFN 14L	14	1x3x0.55mm	3000	3000	178/60	100	400	100	400	8	4

Carrier Tape Drawing and Dimensions

Package Type	Pocket BTM Length [mm]	Pocket BTM Width [mm]	Pocket Depth [mm]	Index Hole Pitch [mm]	Pocket Pitch [mm]	Index Hole Diameter [mm]	Index Hole to Tape Edge [mm]	Index Hole to Pocket Center [mm]	Tape Width [mm]
	A0	B0	K0	P0	P1	D0	E	F	W
STDFN 14L	1.15	3.15	0.7	4	4	1.5	1.75	3.5	8

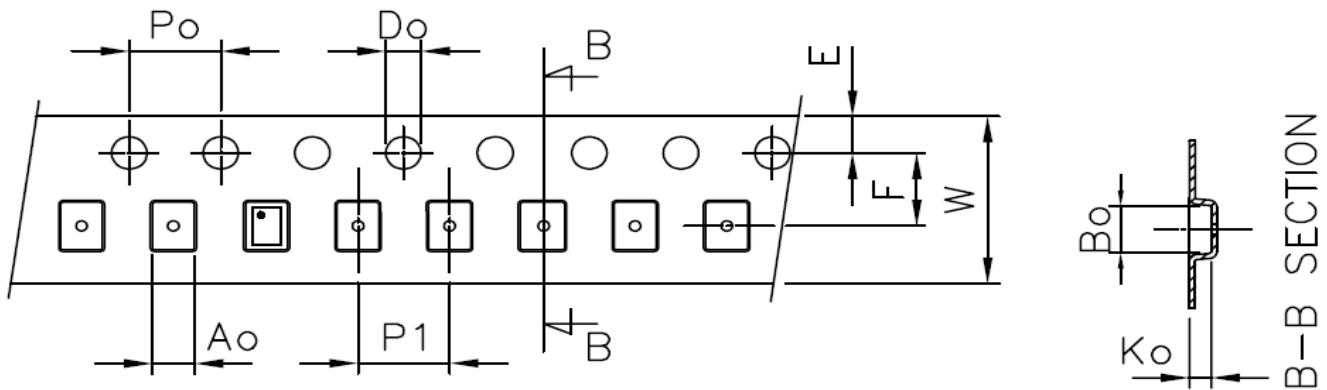

Recommended Reflow Soldering Profile

Please see IPC/JEDEC J-STD-020: latest revision for reflow profile based on package volume of 1.65 mm³ (nominal). More information can be found at www.jedec.org.



Revision History

Date	Version	Change
2/16/2018	1.02	Updated VDD Max to 5 V Added UL certification
10/26/2017	1.01	Updated Part Code Marking Fixed typos
10/03/2017	1.00	Production Release

Компания «Life Electronics» занимается поставками электронных компонентов импортного и отечественного производства от производителей и со складов крупных дистрибьюторов Европы, Америки и Азии.

С конца 2013 года компания активно расширяет линейку поставок компонентов по направлению коаксиальный кабель, кварцевые генераторы и конденсаторы (керамические, пленочные, электролитические), за счёт заключения дистрибьюторских договоров

Мы предлагаем:

- Конкуренспособные цены и скидки постоянным клиентам.
- Специальные условия для постоянных клиентов.
- Подбор аналогов.
- Поставку компонентов в любых объемах, удовлетворяющих вашим потребностям.
- Приемлемые сроки поставки, возможна ускоренная поставка.
- Доставку товара в любую точку России и стран СНГ.
- Комплексную поставку.
- Работу по проектам и поставку образцов.
- Формирование склада под заказчика.
- Сертификаты соответствия на поставляемую продукцию (по желанию клиента).
- Тестирование поставляемой продукции.
- Поставку компонентов, требующих военную и космическую приемку.
- Входной контроль качества.
- Наличие сертификата ISO.

В составе нашей компании организован Конструкторский отдел, призванный помогать разработчикам, и инженерам.

Конструкторский отдел помогает осуществить:

- Регистрацию проекта у производителя компонентов.
- Техническую поддержку проекта.
- Защиту от снятия компонента с производства.
- Оценку стоимости проекта по компонентам.
- Изготовление тестовой платы монтаж и пусконаладочные работы.



Тел: +7 (812) 336 43 04 (многоканальный)
Email: org@lifeelectronics.ru