



GS2994 Adaptive Cable Equalizer

Key Features

- SMPTE 424M, SMPTE 292M and SMPTE 259M compliant
- Automatic cable equalization
- Multi-standard operation from 143Mb/s to 2.97Gb/s
- Performance optimized for 270Mb/s, 1.485Gb/s and 2.97Gb/s. Typical equalized length of Belden 1694A cable:
 - ◆ 140m at 2.97Gb/s
 - ◆ 200m at 1.485Gb/s
 - ◆ 400m at 270Mb/s
- Supports DVB-ASI at 270Mb/s
- Manual bypass (useful for low data rates with slow rise/fall times)
- Programmable carrier detect with squelch threshold adjustment
- Automatic power-down on loss of signal
 - ◆ Standby power <30mW (typical)
- Differential outputs support DC-coupling to 1.2V, 2.5V and 3.3V CML logic
- 0/6 dB gain boost selection pin
- Selectable de-emphasis: 2dB, 4dB and 6dB
- Standard EIA/JEDEC logic control and status signal levels
- Single 3.3V power supply operation
- 167mW power consumption (typical)
- Wide operating temperature range of -40°C to +85°C
- Small footprint QFN package (4mm x 4mm)
 - ◆ Footprint compatible with the GS2974 and the GS2984
- Pb-free and RoHS compliant

Applications

- SMPTE 424M, SMPTE 292M and SMPTE 259M coaxial cable serial digital interfaces

Description

The GS2994 is a high-speed BiCMOS integrated circuit designed to equalize and restore signals received over 75Ω coaxial cable.

The device is designed to support SMPTE 424M, SMPTE292M and SMPTE 259M, and is optimized for performance at 270Mb/s, 1.485Gb/s and 2.97Gb/s.

The GS2994 features DC restoration to compensate for the DC content of SMPTE pathological test patterns.

The Carrier Detect output pin (\overline{CD}) indicates whether a valid input signal has been detected. It can be connected directly to the SLEEP pin to enable automatic power-down upon loss of carrier. In the manual sleep mode, a voltage programmable threshold, which can be changed via the SQ_ADJ pin, forces \overline{CD} high when the input signal amplitude falls below the threshold. This allows the GS2994 to distinguish between low-amplitude SDI signals and noise at the input of the device.

The equalizing and DC restore stages are disengaged when the BYPASS pin is HIGH. No equalization occurs in Bypass mode.

The GS2994 includes a gain selection pin (GAIN_SEL) which, when tied HIGH, compensates for 6dB flat attenuation.

The differential outputs can be DC-coupled to Gennum 3.3V cable drivers and reclockers and to industry-standard 1.2V, 2.5V and 3.3V CML logic using the VCC_O pin. In general, DC-coupling to any termination voltage between 1.2V and 3.3V is supported.

The GS2994 also includes programmable de-emphasis with three operating levels in order to support long PCB traces.

The GS2994 is footprint and drop-in compatible with existing GS2974 and GS2984 designs.

The device is available in a 16-pin, 4mm x 4mm QFN package.

Power consumption of the GS2994 is typically 167mW when DC-coupled at 1.2V.

The GS2994 is Pb-free, and the encapsulation compound does not contain halogenated flame retardant.

This component and all homogeneous subcomponents are RoHS compliant.

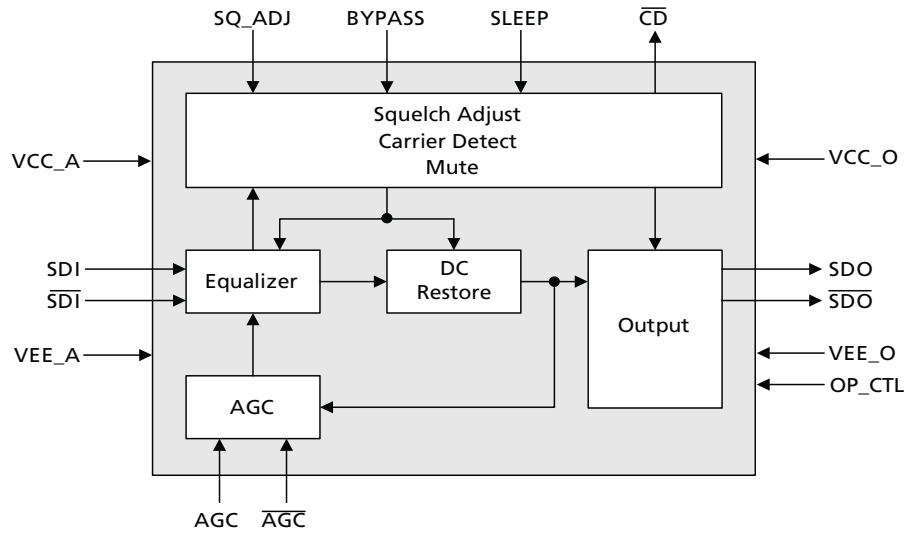

GS2994 Functional Block Diagram

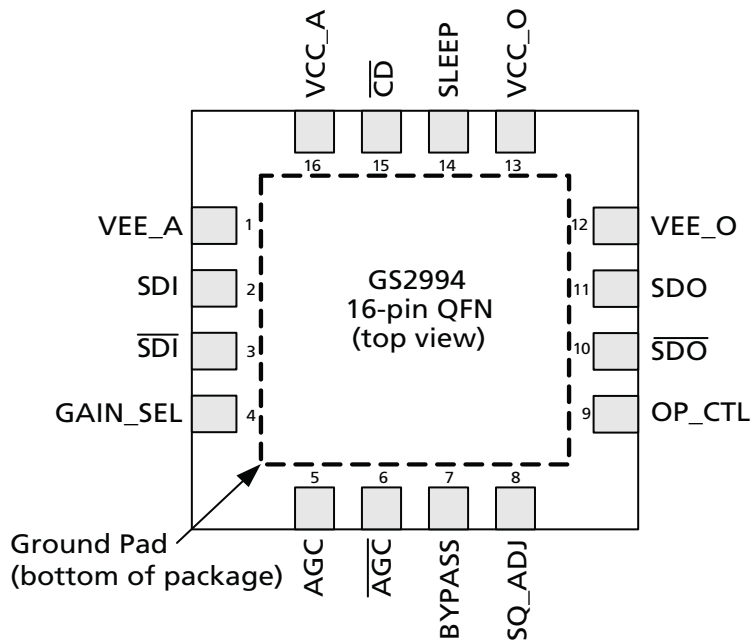

GS2994 Pin Out

**DOCUMENT IDENTIFICATION
PRODUCT BRIEF**

The product is in a development phase and specifications are subject to change without notice. Gennum reserves the right to remove the product at any time. Listing the product does not constitute an offer for sale.

CAUTION

ELECTROSTATIC SENSITIVE DEVICES

DO NOT OPEN PACKAGES OR HANDLE EXCEPT AT A
STATIC-FREE WORKSTATION

GENNUM CORPORATE HEADQUARTERS

4281 Harvester Road, Burlington, Ontario L7L 5M4 Canada

Phone: +1 (905) 632-2996

E-mail: corporate@gennum.com

Fax: +1 (905) 632-2055

www.gennum.com

OTTAWA232 Herzberg Road, Suite 101
Kanata, Ontario K2K 2A1
Canada

Phone: +1 (613) 270-0458

Fax: +1 (613) 270-0429

CALGARY3553 - 31st St. N.W., Suite 210
Calgary, Alberta T2L 2K7
Canada

Phone: +1 (403) 284-2672

UNITED KINGDOMNorth Building, Walden Court
Parsonage Lane,
Bishop's Stortford Hertfordshire, CM23 5DB
United Kingdom

Phone: +44 1279 714170

Fax: +44 1279 714171

INDIA#208(A), Nirmala Plaza,
Airport Road, Forest Park Square
Bhubaneswar 751009
India

Phone: +91 (674) 653-4815

Fax: +91 (674) 259-5733

SNOWBUSH IP - A DIVISION OF GENNUM439 University Ave. Suite 1700
Toronto, Ontario M5G 1Y8
Canada

Phone: +1 (416) 925-5643

Fax: +1 (416) 925-0581

E-mail: sales@snowbush.comWeb Site: <http://www.snowbush.com>**MEXICO**288-A Paseo de Maravillas
Jesus Ma., Aguascalientes
Mexico 20900

Phone: +1 (416) 848-0328

JAPAN KKShinjuku Green Tower Building 27F
6-14-1, Nishi Shinjuku
Shinjuku-ku, Tokyo, 160-0023
Japan

Phone: +81 (03) 3349-5501

Fax: +81 (03) 3349-5505

E-mail: gennum-japan@gennum.comWeb Site: <http://www.gennum.co.jp>**TAIWAN**6F-4, No.51, Sec.2, Keelung Rd.
Sinyi District, Taipei City 11502
Taiwan R.O.C.

Phone: (886) 2-8732-8879

Fax: (886) 2-8732-8870

E-mail: gennum-taiwan@gennum.com**GERMANY**Hainbuchenstraße 2
80935 Muenchen (Munich), Germany

Phone: +49-89-35831696

Fax: +49-89-35804653

E-mail: gennum-germany@gennum.com**NORTH AMERICA WESTERN REGION**691 South Milpitas Blvd., Suite #200
Milpitas, CA 95035
United States

Phone: +1 (408) 934-1301

Fax: +1 (408) 934-1029

E-mail: naw_sales@gennum.com**NORTH AMERICA EASTERN REGION**4281 Harvester Road
Burlington, Ontario L7L 5M4
Canada

Phone: +1 (905) 632-2996

Fax: +1 (905) 632-2055

E-mail: nae_sales@gennum.com**KOREA**8F Jinnex Lakeview Bldg.
65-2, Bangidong, Songpagu
Seoul, Korea 138-828

Phone: +82-2-414-2991

Fax: +82-2-414-2998

E-mail: gennum-korea@gennum.com

Gennum Corporation assumes no liability for any errors or omissions in this document, or for the use of the circuits or devices described herein. The sale of the circuit or device described herein does not imply any patent license, and Gennum makes no representation that the circuit or device is free from patent infringement.

All other trademarks mentioned are the properties of their respective owners.

GENNUM and the Gennum logo are registered trademarks of Gennum Corporation.

© Copyright 2009 Gennum Corporation. All rights reserved.

www.gennum.com

Компания «Life Electronics» занимается поставками электронных компонентов импортного и отечественного производства от производителей и со складов крупных дистрибьюторов Европы, Америки и Азии.

С конца 2013 года компания активно расширяет линейку поставок компонентов по направлению коаксиальный кабель, кварцевые генераторы и конденсаторы (керамические, пленочные, электролитические), за счёт заключения дистрибьюторских договоров

Мы предлагаем:

- Конкурентоспособные цены и скидки постоянным клиентам.
- Специальные условия для постоянных клиентов.
- Подбор аналогов.
- Поставку компонентов в любых объемах, удовлетворяющих вашим потребностям.
- Приемлемые сроки поставки, возможна ускоренная поставка.
- Доставку товара в любую точку России и стран СНГ.
- Комплексную поставку.
- Работу по проектам и поставку образцов.
- Формирование склада под заказчика.
- Сертификаты соответствия на поставляемую продукцию (по желанию клиента).
- Тестирование поставляемой продукции.
- Поставку компонентов, требующих военную и космическую приемку.
- Входной контроль качества.
- Наличие сертификата ISO.

В составе нашей компании организован Конструкторский отдел, призванный помогать разработчикам, и инженерам.

Конструкторский отдел помогает осуществить:

- Регистрацию проекта у производителя компонентов.
- Техническую поддержку проекта.
- Защиту от снятия компонента с производства.
- Оценку стоимости проекта по компонентам.
- Изготовление тестовой платы монтаж и пусконаладочные работы.



Тел: +7 (812) 336 43 04 (многоканальный)

Email: org@lifeelectronics.ru