

NUD4011

Low Current LED Driver

This device is designed to replace discrete solutions for driving LEDs in AC/DC high voltage applications (up to 200 V). An external resistor allows the circuit designer to set the drive current for different LED arrays. This discrete integration technology eliminates individual components by combining them into a single package, which results in a significant reduction of both system cost and board space. The device is a small surface mount package (SO-8).

Features

- Supplies Constant LED Current for Varying Input Voltages
- External Resistor Allows Designer to Set Current – up to 70 mA
- Offered in Surface Mount Package Technology (SO-8)
- Pb-Free Package is Available

Benefits

- Maintains a Constant Light Output During Battery Drain
- One Device can be used for Many Different LED Products
- Reduces Board Space and Component Count
- Simplifies Circuit and System Designs

Typical Applications

- Portables: For Battery Back-up Applications, also Simple Ni-CAD Battery Charging
- Industrial: General Lighting Applications and Small Appliances
- Automotive: Tail Lights, Directional Lights, Back-up Light, Dome Light

PIN FUNCTION DESCRIPTION

Pin	Symbol	Description
1	V_{in}	Positive input voltage to the device
2	Boost	This pin may be used to drive an external transistor as described in the App Note AND8198/D.
3	R_{ext}	An external resistor between R_{ext} and V_{in} pins sets different current levels for different application needs
4	PWM	For high voltage applications (higher than 48 V), pin 4 is connected to the LEDs array. For low voltage applications (lower than 48 V), pin 4 is connected to ground.
5, 6, 7, 8	I_{out}	The LEDs are connected from these pins to ground



ON Semiconductor®

<http://onsemi.com>

PIN CONFIGURATION AND SCHEMATIC

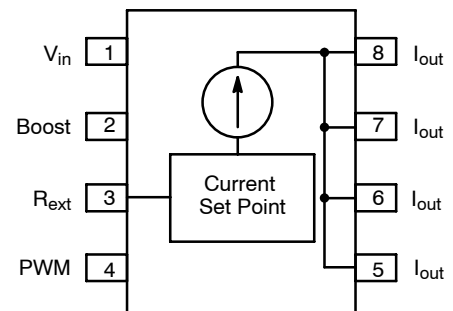

MARKING DIAGRAM

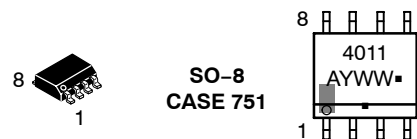

A = Assembly Location
 Y = Year
 WW = Work Week
 ■ = Pb-Free Package
 (Note: Microdot may be in either location)

ORDERING INFORMATION

Device	Package	Shipping [†]
NUD4011DR2	SO-8	2500 / Tape & Reel
NUD4011DR2G	SO-8 (Pb-Free)	2500 / Tape & Reel

[†]For information on tape and reel specifications, including part orientation and tape sizes, please refer to our Tape and Reel Packaging Specification Brochure, BRD8011/D.

NUD4011

MAXIMUM RATINGS ($T_A = 25^\circ\text{C}$ unless otherwise noted)

Rating	Symbol	Value	Unit
Input Voltage	V_{in}	200	V
Output Current (For $V_{drop} \leq 16\text{ V}$) (Note 1)	I_{out}	70	mA
Output Voltage	V_{out}	198	V
Human Body Model (HBM)	ESD	500	V

Stresses exceeding Maximum Ratings may damage the device. Maximum Ratings are stress ratings only. Functional operation above the Recommended Operating Conditions is not implied. Extended exposure to stresses above the Recommended Operating Conditions may affect device reliability.

1. $V_{drop} = V_{in} - 0.7\text{ V} - V_{LEDs}$.

THERMAL CHARACTERISTICS

Characteristic	Symbol	Value	Unit
Operating Ambient Temperature	T_A	-40 to +125	$^\circ\text{C}$
Maximum Junction Temperature	T_J	150	$^\circ\text{C}$
Storage Temperature	T_{STG}	-55 to +150	$^\circ\text{C}$
Total Power Dissipation (Note 2) Derating above 25°C (Figure 3)	P_D	1.13 9.0	W mW/ $^\circ\text{C}$
Thermal Resistance, Junction-to-Ambient (Note 2)	$R_{\theta JA}$	110	$^\circ\text{C/W}$
Thermal Resistance, Junction-to-Lead (Note 2)	$R_{\theta JL}$	77	$^\circ\text{C/W}$

2. Mounted on FR-4 board, 2 in sq pad, 1 oz coverage.

ELECTRICAL CHARACTERISTICS ($T_A = 25^\circ\text{C}$ unless otherwise noted)

Characteristic	Symbol	Min	Typ	Max	Unit
Output Current1 (Note 3) ($V_{in} = 120\text{ Vdc}$, $R_{ext} = 24\ \Omega$, $V_{LEDs} = 90\text{ V}$)	I_{out1}	26.0	27.5	29.5	mA
Output Current2 (Note 3) ($V_{in} = 200\text{ Vdc}$, $R_{ext} = 68\ \Omega$, $V_{LEDs} = 120\text{ V}$)	I_{out2}	11.5	14.0	15.5	mA
Bias Current ($V_{in} = 120\text{ Vdc}$, $R_{ext} = \text{Open}$, $R_{shunt} = 80\text{ k}\Omega$)	I_{Bias}	-	1.1	2.0	mA
Voltage Overhead (Note 4)	V_{over}	5.0	-	-	V

3. Device's pin 4 connected to the LEDs array (as shown in Figure 5).

4. $V_{over} = V_{in} - V_{LEDs}$.

NUD4011

TYPICAL PERFORMANCE CURVES

($T_A = 25^\circ\text{C}$ unless otherwise noted)

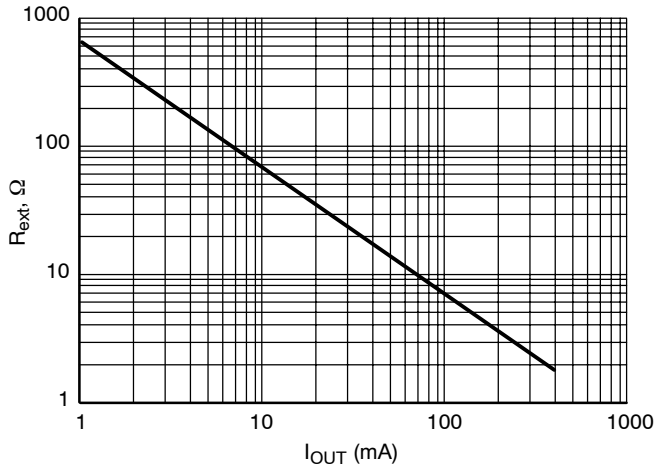

Figure 1. Output Current (I_{OUT}) vs. External Resistor (R_{ext})

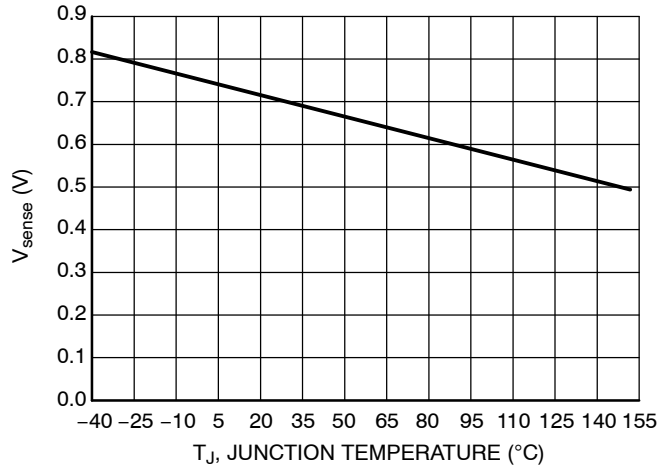

Figure 2. V_{sense} vs. Junction Temperature

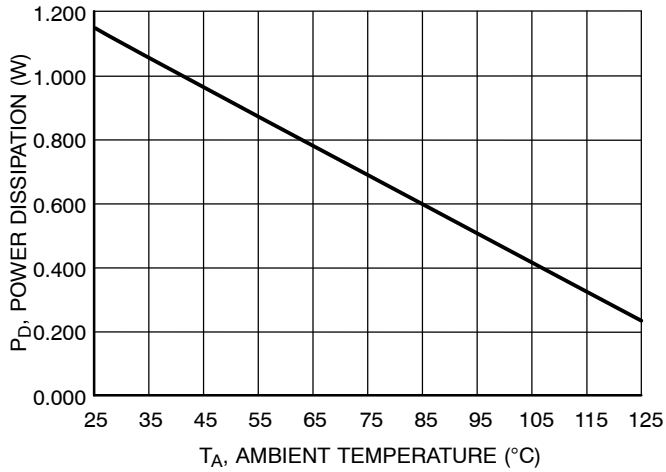

Figure 3. Total Power Dissipation (P_D) vs. Ambient Temperature (T_A)

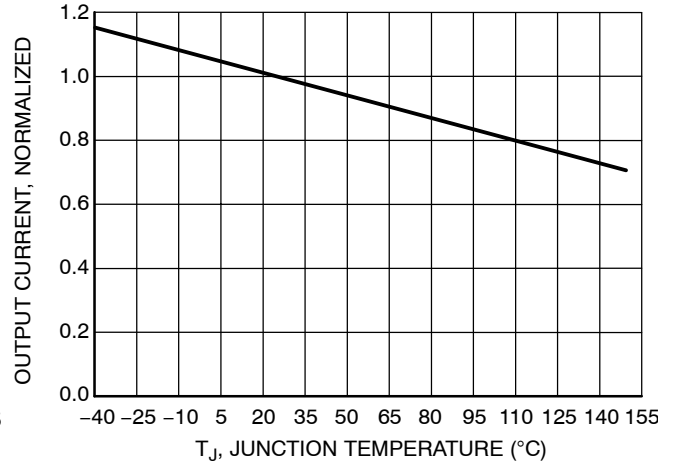

Figure 4. Current Regulation vs. Junction Temperature

APPLICATION INFORMATION

Design Guide for DC Applications

1. Define LED's current:
 - a. $I_{LED} = 30 \text{ mA}$
2. Calculate Resistor Value for R_{ext} :
 - a. $R_{ext} = V_{sense} / I_{LED}$ (see Figure 2)
 - b. $R_{ext} = 0.7(T_J = 25 \text{ }^\circ\text{C}) / 0.030 = 24 \text{ } \Omega$
3. Define V_{in} :
 - a. Per example in Figure 5, $V_{in} = 120 \text{ Vdc}$
4. Define $V_{LED} @ I_{LED}$ per LED supplier's data sheet: per example in Figure 5,
 - a. $V_{LED} = 3.0 \text{ V}$ (30 LEDs in series)
 - b. $V_{LEDs} = 90 \text{ V}$
5. Calculate V_{drop} across the NUD4001 device:
 - a. $V_{drop} = V_{in} - V_{sense} - V_{LEDs}$
 - b. $V_{drop} = 120 \text{ V} - 0.7 \text{ V} - 90 \text{ V}$
 - c. $V_{drop} = 29.3 \text{ V}$
6. Calculate Power Dissipation on the NUD4001 device's driver:
 - a. $P_{D_driver} = V_{drop} * I_{out}$
 - b. $P_{D_driver} = 29.3 \text{ V} \times 0.030 \text{ A}$
 - c. $P_{D_driver} = 0.879 \text{ W}$
7. Establish Power Dissipation on the NUD4001 device's control circuit per below formula:
 - a. $P_{D_control} = (V_{in} - 1.4 - V_{LEDs})^2 / 20,000$
 - b. $P_{D_control} = 0.040 \text{ W}$
8. Calculate Total Power Dissipation on the device:
 - a. $P_{D_total} = P_{D_driver} + P_{D_control}$
 - b. $P_{D_total} = 0.879 \text{ W} + 0.040 \text{ W} = 0.919 \text{ W}$
9. If $P_{D_total} > 1.13 \text{ W}$ (or derated value per Figure 3), then select the most appropriate recourse and repeat steps 1–8:
 - a. Reduce V_{in}
 - b. Reconfigure LED array to reduce V_{drop}
 - c. Reduce I_{out} by increasing R_{ext}
 - d. Use external resistors or parallel device's configuration
10. Calculate the junction temperature using the thermal information on Page 8 and refer to Figure 4 to check the output current drop due to the calculated junction temperature. If desired, compensate it by adjusting the value of R_{ext} .

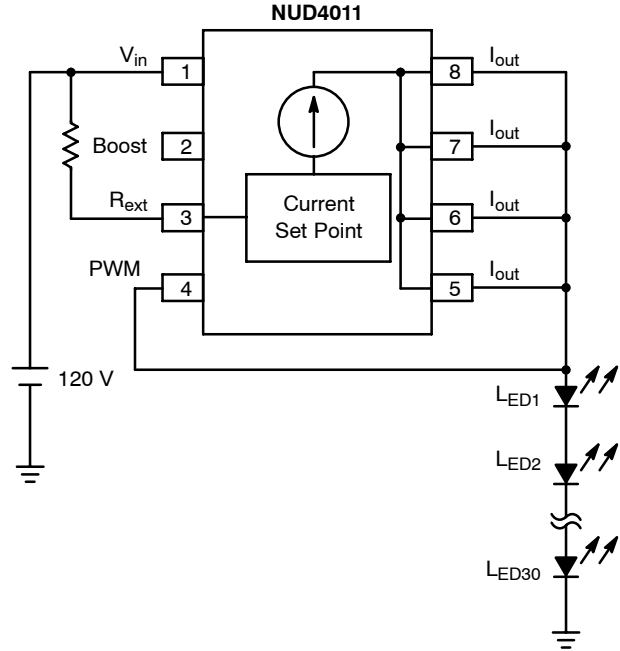

Figure 5. 120 V Application (Series LED's Array)

APPLICATION INFORMATION (continued)

Design Guide for AC Applications

1. Define LED's current:
 - a. $I_{LED} = 30 \text{ mA}$
2. Define V_{in} :
 - a. Per example in Figure 5, $V_{in} = 120 \text{ Vac}$
3. Define $V_{LED} @ I_{LED}$ per LED supplier's data sheet:
 - a. Per example in Figure 6,

$$V_{LED} = 3.0 \text{ V (30 LEDs in series)}$$

$$V_{LEDs} = 90 \text{ V}$$
4. Calculate Resistor Value for R_{ext} :

The calculation of the R_{ext} for AC applications is totally different than for DC. This is because current conduction only occurs during the time that the ac cycles' amplitude is higher than V_{LEDs} . Therefore R_{ext} calculation is now dependent on the peak current value and the conduction time.

 - a. Calculate θ for $V_{LEDs} = 90 \text{ V}$:

$$V = V_{peak} \times \text{Sin } \theta$$

$$90 \text{ V} = (120 \times \sqrt{2}) \times \text{Sin } \theta$$

$$\theta = 32.027^\circ$$
 - b. Calculate conduction time for $\theta = 32.027^\circ$. For a sinusoidal waveform V_{peak} happens at $\theta = 90^\circ$. This translates to 4.165 ms in time for a 60 Hz frequency, therefore 32.027° is 1.48 ms and finally:

$$\text{Conduction time} = (4.165 \text{ ms} - 1.48 \text{ ms}) \times 2$$

$$= 5.37 \text{ ms}$$
 - c. Calculate the I_{peak} needed for $I_{(avg)} = 30 \text{ mA}$
 Since a full bridge rectifier is being used (per Figure 6), the frequency of the voltage signal applied to the NUD4011 device is now 120 Hz. To simplify the calculation, it is assumed that the 120 Hz waveform is square shaped so that the following formula can be used:

$$I_{(avg)} = I_{peak} \times \text{duty cycle};$$
 If 8.33 ms is 100% duty cycle, then 5.37 ms is 64.46%, then:

$$I_{peak} = I_{(avg)} / \text{duty cycle}$$

$$I_{peak} = 30 \text{ mA} / 0.645 = 46 \text{ mA}$$
 - d. Calculate R_{ext}

$$R_{ext} = 0.7 \text{ V} / I_{peak}$$

$$R_{ext} = 15.21 \Omega$$
5. Calculate V_{drop} across the NUD4011 device:
 - a. $V_{drop} = V_{in} - V_{sense} - V_{LEDs}$
 - b. $V_{drop} = 120 \text{ V} - 0.7 \text{ V} - 90 \text{ V}$
 - c. $V_{drop} = 29.3 \text{ V}$

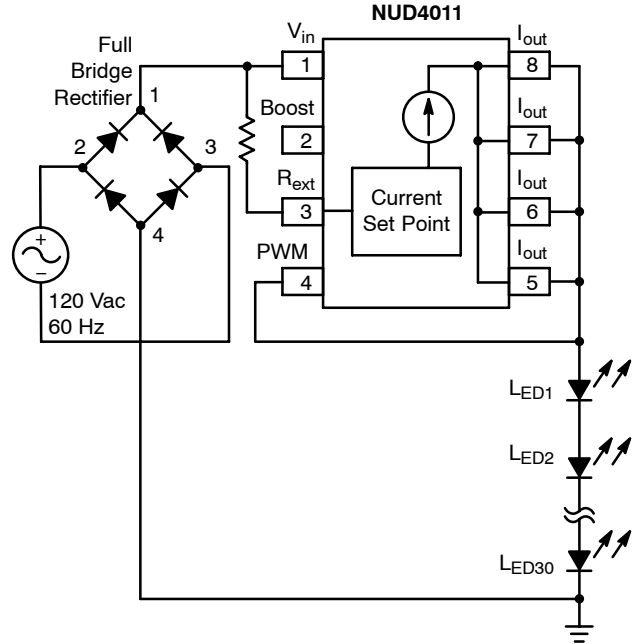

Figure 6. 120 Vac Application (Series LED's array)

6. Calculate Power Dissipation on the NUD4011 device's driver:
 - a. $P_{D_driver} = V_{drop} * I_{(avg)}$
 - b. $P_{D_driver} = 29.3 \text{ V} \times 0.030 \text{ A}$
 - c. $P_{D_driver} = 0.879 \text{ W}$
7. Establish Power Dissipation on the NUD4011 device's control circuit per below formula:
 - a. $P_{D_control} = (V_{in} - 1.4 - V_{LEDs})^2 / 20,000$
 - b. $P_{D_control} = 0.040 \text{ W}$
8. Calculate Total Power Dissipation on the device:
 - a. $P_{D_total} = P_{D_driver} + P_{D_control}$
 - b. $P_{D_total} = 0.879 \text{ W} + 0.040 \text{ W} = 0.919 \text{ W}$
9. If $P_{D_total} > 1.13 \text{ W}$ (or derated value per Figure 3), then select the most appropriate recourse and repeat steps 1-8:
 - a. Reduce V_{in}
 - b. Reconfigure LED array to reduce V_{drop}
 - c. Reduce I_{out} by increasing R_{ext}
 - d. Use external resistors or parallel device's configuration
10. Calculate the junction temperature using the thermal information on Page 8 and refer to Figure 4 to check the output current drop due to the calculated junction temperature. If desired, compensate it by adjusting the value of R_{ext} .

NUD4011

TYPICAL APPLICATION CIRCUITS

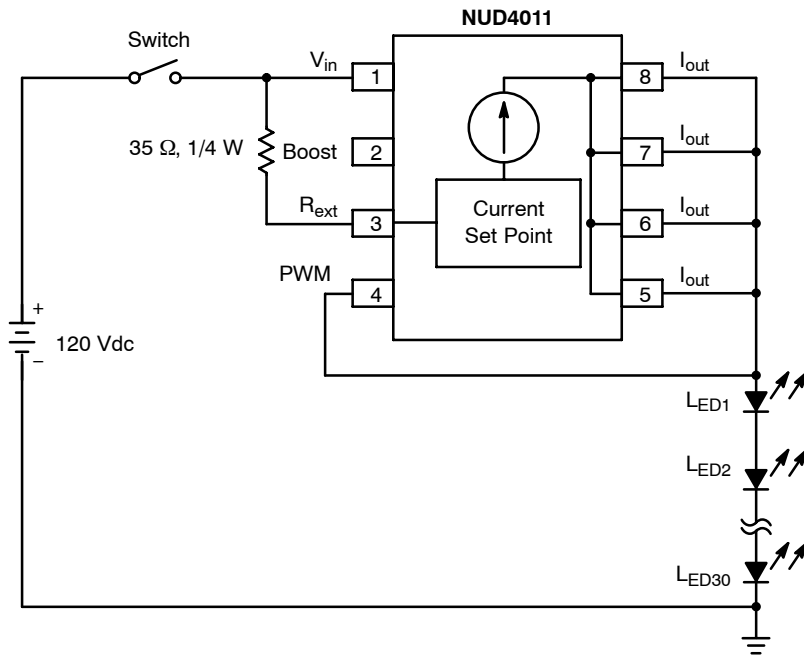

Figure 7. 120 Vdc Application Circuit for a Series Array of 30 LEDs (3.0 V, 20 mA)

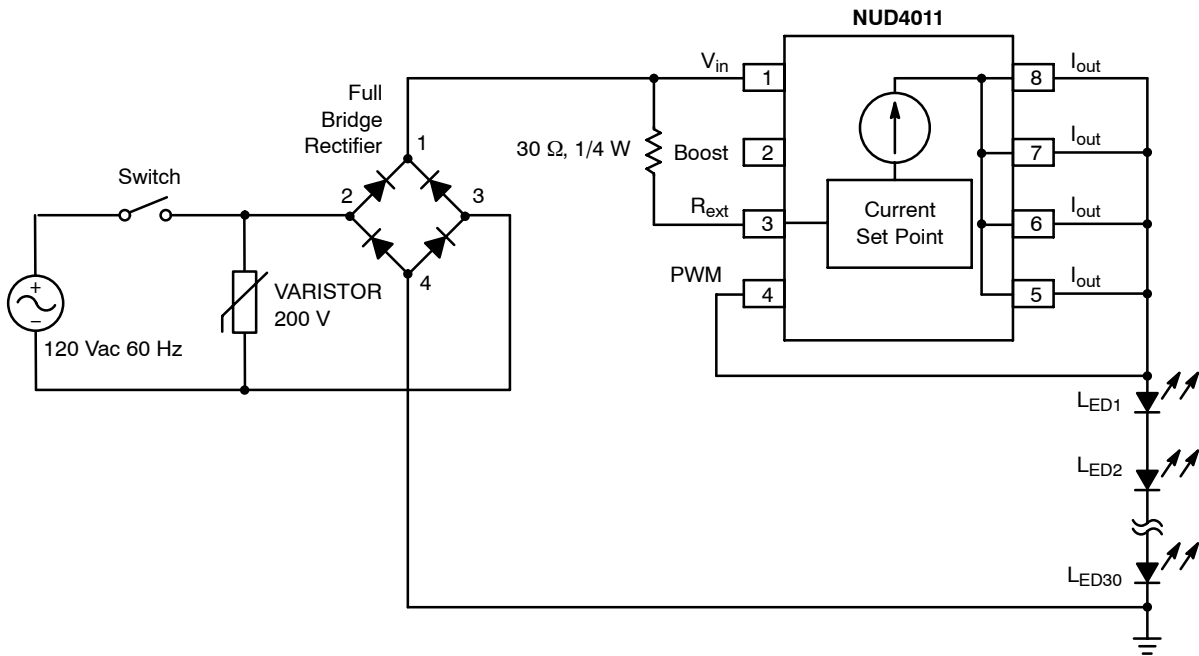

Figure 8. 120 Vac Application Circuit for a Series Array of 30 LEDs (3.0 V, 20 mA)

NUD4011

TYPICAL APPLICATION CIRCUITS (continued)

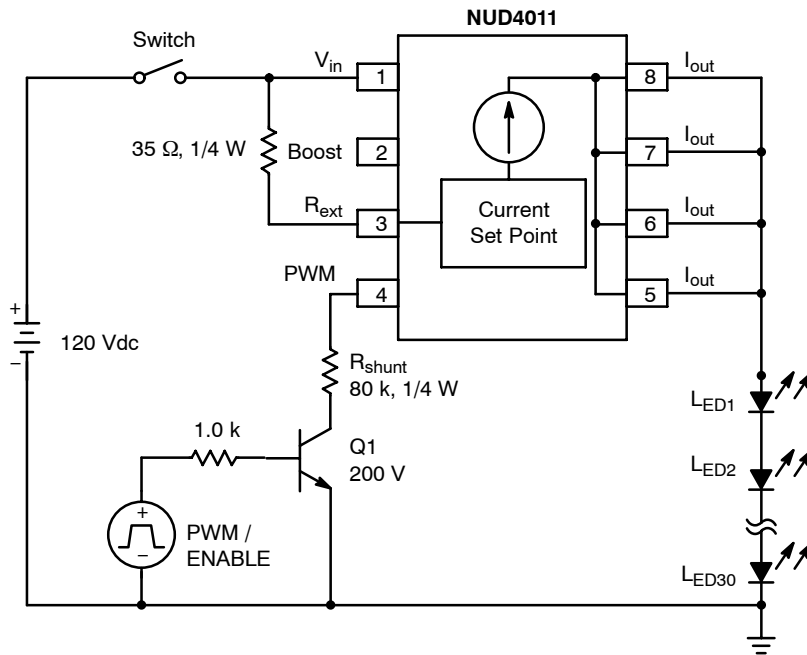

Figure 9. 120 Vdc Application with PWM / Enable Function, 30 LEDs in Series (3.0 V, 20 mA)

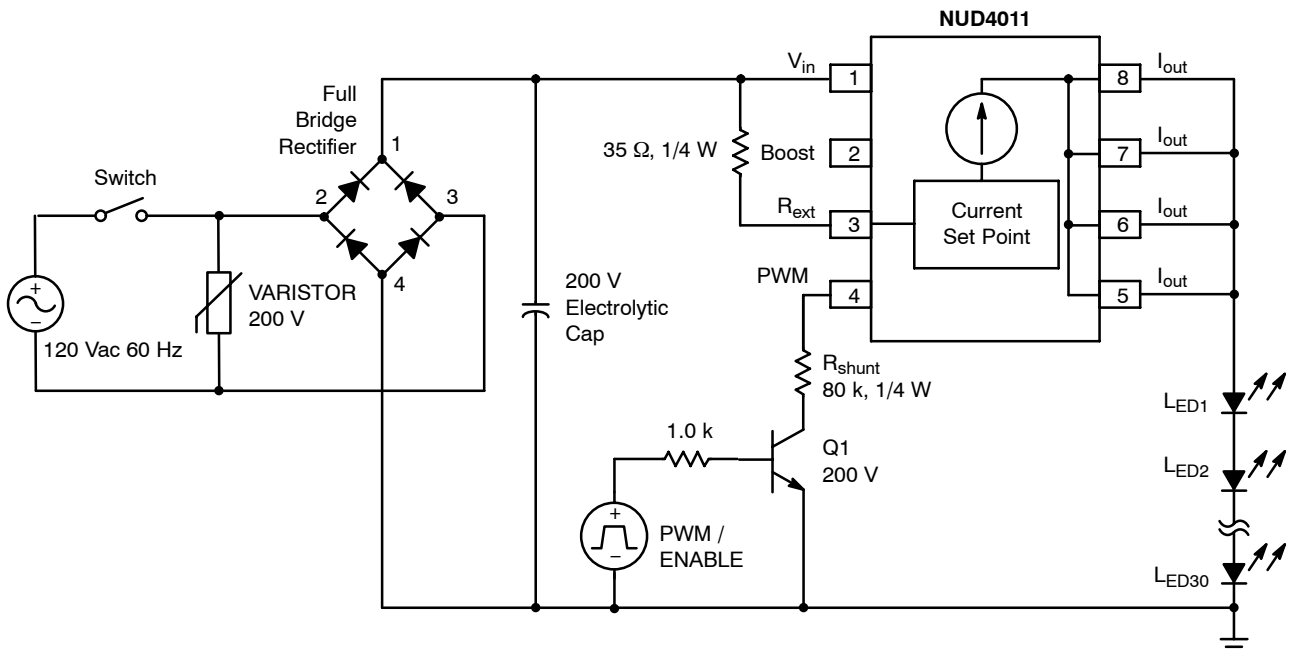

Figure 10. 120 Vac Application with PWM / Enable Function, 30 LEDs in Series (3.0 V, 20 mA)

THERMAL INFORMATION

NUD4011 Power Dissipation

The power dissipation of the SO-8 is a function of the pad size. This can vary from the minimum pad size for soldering to a pad size given for maximum power dissipation. Power dissipation for a surface mount device is determined by $T_{J(max)}$, the maximum rated junction temperature of the die, $R_{\theta JA}$, the thermal resistance from the device junction to ambient, and the operating temperature, T_A . Using the values provided on the data sheet for the SO-8 package, P_D can be calculated as follows:

$$P_D = \frac{T_{Jmax} - T_A}{R_{\theta JA}}$$

The values for the equation are found in the maximum ratings table on the data sheet. Substituting these values into the equation for an ambient temperature T_A of 25°C, one can calculate the power dissipation of the device which in this case is 1.13 W.

$$P_D = \frac{150^{\circ}C - 25^{\circ}C}{110^{\circ}C} = 1.13 W$$

The 110°C/W for the SO-8 package assumes the use of a FR-4 copper board with an area of 2 square inches with 2 oz coverage to achieve a power dissipation of 1.13 W. There are other alternatives to achieving higher dissipation from the SOIC package. One of them is to increase the copper area to

reduce the thermal resistance. Figure 11 shows how the thermal resistance changes for different copper areas. Another alternative would be to use a ceramic substrate or an aluminum core board such as Thermal Clad®. Using a board material such as Thermal Clad or an aluminum core board, the power dissipation can be even doubled using the same footprint.

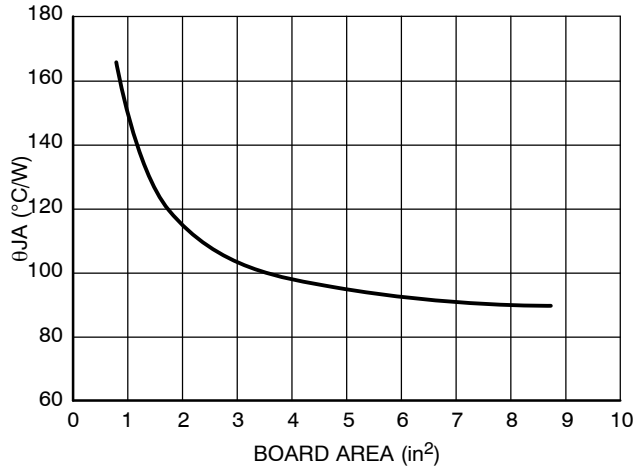

Figure 11. θJA versus Board Area

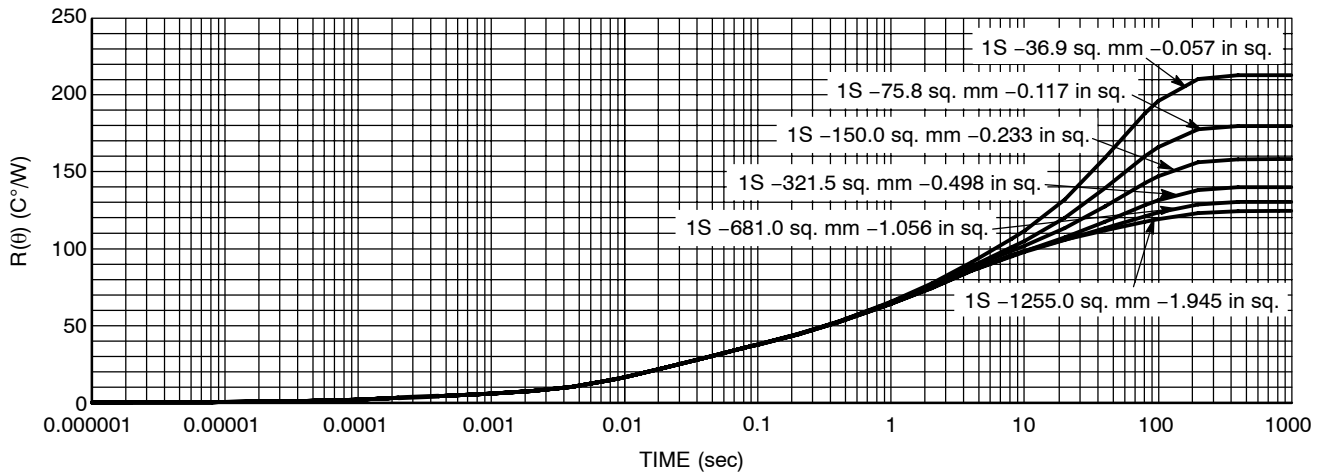
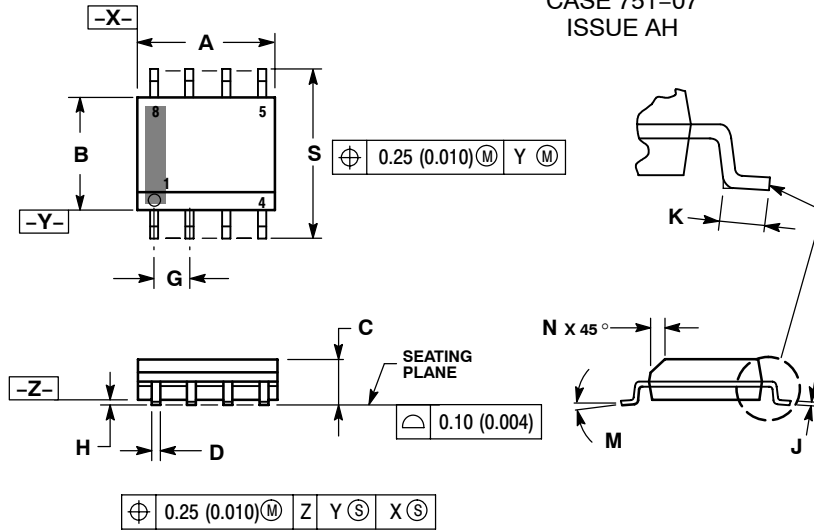

Figure 12. Transient Thermal Response

NUD4011

PACKAGE DIMENSIONS

SOIC-8 NB CASE 751-07 ISSUE AH



NOTES:

1. DIMENSIONING AND TOLERANCING PER ANSI Y14.5M, 1982.
2. CONTROLLING DIMENSION: MILLIMETER.
3. DIMENSION A AND B DO NOT INCLUDE MOLD PROTRUSION.
4. MAXIMUM MOLD PROTRUSION 0.15 (0.006) PER SIDE.
5. DIMENSION D DOES NOT INCLUDE DAMBAR PROTRUSION. ALLOWABLE DAMBAR PROTRUSION SHALL BE 0.127 (0.005) TOTAL IN EXCESS OF THE D DIMENSION AT MAXIMUM MATERIAL CONDITION.
6. 751-01 THRU 751-06 ARE OBSOLETE. NEW STANDARD IS 751-07.

DIM	MILLIMETERS		INCHES	
	MIN	MAX	MIN	MAX
A	4.80	5.00	0.189	0.197
B	3.80	4.00	0.150	0.157
C	1.35	1.75	0.053	0.069
D	0.33	0.51	0.013	0.020
G	1.27 BSC		0.050 BSC	
H	0.10	0.25	0.004	0.010
J	0.19	0.25	0.007	0.010
K	0.40	1.27	0.016	0.050
M	0°	8°	0°	8°
N	0.25	0.50	0.010	0.020
S	5.80	6.20	0.228	0.244

SOLDERING FOOTPRINT*

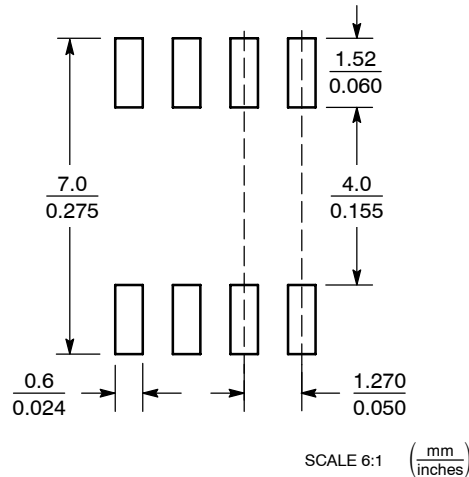

*For additional information on our Pb-Free strategy and soldering details, please download the ON Semiconductor Soldering and Mounting Techniques Reference Manual, SOLDERRM/D.

Thermal Clad is a registered trademark of the Bergquist Company.

ON Semiconductor and are registered trademarks of Semiconductor Components Industries, LLC (SCILLC). SCILLC reserves the right to make changes without further notice to any products herein. SCILLC makes no warranty, representation or guarantee regarding the suitability of its products for any particular purpose, nor does SCILLC assume any liability arising out of the application or use of any product or circuit, and specifically disclaims any and all liability, including without limitation special, consequential or incidental damages. "Typical" parameters which may be provided in SCILLC data sheets and/or specifications can and do vary in different applications and actual performance may vary over time. All operating parameters, including "Typicals" must be validated for each customer application by customer's technical experts. SCILLC does not convey any license under its patent rights nor the rights of others. SCILLC products are not designed, intended, or authorized for use as components in systems intended for surgical implant into the body, or other applications intended to support or sustain life, or for any other application in which the failure of the SCILLC product could create a situation where personal injury or death may occur. Should Buyer purchase or use SCILLC products for any such unintended or unauthorized application, Buyer shall indemnify and hold SCILLC and its officers, employees, subsidiaries, affiliates, and distributors harmless against all claims, costs, damages, and expenses, and reasonable attorney fees arising out of, directly or indirectly, any claim of personal injury or death associated with such unintended or unauthorized use, even if such claim alleges that SCILLC was negligent regarding the design or manufacture of the part. SCILLC is an Equal Opportunity/Affirmative Action Employer. This literature is subject to all applicable copyright laws and is not for resale in any manner.

PUBLICATION ORDERING INFORMATION

LITERATURE FULFILLMENT:
Literature Distribution Center for ON Semiconductor
P.O. Box 5163, Denver, Colorado 80217 USA
Phone: 303-675-2175 or 800-344-3860 Toll Free USA/Canada
Fax: 303-675-2176 or 800-344-3867 Toll Free USA/Canada
Email: orderlit@onsemi.com

N. American Technical Support: 800-282-9855 Toll Free
USA/Canada
Europe, Middle East and Africa Technical Support:
Phone: 421 33 790 2910
Japan Customer Focus Center
Phone: 81-3-5773-3850

ON Semiconductor Website: www.onsemi.com
Order Literature: <http://www.onsemi.com/orderlit>

For additional information, please contact your local Sales Representative

Компания «Life Electronics» занимается поставками электронных компонентов импортного и отечественного производства от производителей и со складов крупных дистрибьюторов Европы, Америки и Азии.

С конца 2013 года компания активно расширяет линейку поставок компонентов по направлению коаксиальный кабель, кварцевые генераторы и конденсаторы (керамические, пленочные, электролитические), за счёт заключения дистрибьюторских договоров

Мы предлагаем:

- Конкурентоспособные цены и скидки постоянным клиентам.
- Специальные условия для постоянных клиентов.
- Подбор аналогов.
- Поставку компонентов в любых объемах, удовлетворяющих вашим потребностям.
- Приемлемые сроки поставки, возможна ускоренная поставка.
- Доставку товара в любую точку России и стран СНГ.
- Комплексную поставку.
- Работу по проектам и поставку образцов.
- Формирование склада под заказчика.
- Сертификаты соответствия на поставляемую продукцию (по желанию клиента).
- Тестирование поставляемой продукции.
- Поставку компонентов, требующих военную и космическую приемку.
- Входной контроль качества.
- Наличие сертификата ISO.

В составе нашей компании организован Конструкторский отдел, призванный помогать разработчикам, и инженерам.

Конструкторский отдел помогает осуществить:

- Регистрацию проекта у производителя компонентов.
- Техническую поддержку проекта.
- Защиту от снятия компонента с производства.
- Оценку стоимости проекта по компонентам.
- Изготовление тестовой платы монтаж и пусконаладочные работы.



Тел: +7 (812) 336 43 04 (многоканальный)

Email: org@lifeelectronics.ru