

Self-Oscillating Half-Bridge Driver

Features

- Floating channel designed for bootstrap operation
- Integrated 600 V half-bridge gate driver
- 15.6 V zener clamp on Vcc
- True micropower start up
- Tighter initial dead time control
- Low temperature coefficient dead time
- Shutdown feature (1/6th Vcc) on CT pin
- Increased undervoltage lockout Hysteresis (1 V)
- Lower power level-shifting circuit
- Constant LO, HO pulse widths at startup
- Lower di/dt gate driver for better noise immunity
- Low side output in phase with RT
- Excellent latch immunity on all inputs and outputs
- ESD protection on all leads

Description

The IR25603(S) incorporates a high voltage half-bridge gate driver with a front end oscillator similar to the industry standard CMOS 555 timer. A shutdown feature has been designed into the CT pin, so that both gate driver outputs can be disabled using a low voltage control signal. In addition, the gate driver output pulse widths are the same once the rising undervoltage lockout threshold on Vcc has been reached, resulting in a more stable profile of frequency vs time at startup. Special attention has been paid to maximizing the latch immunity of the device and providing comprehensive ESD protection on all pins.

Product Summary

V_{OFFSET}	600 V max.
Duty Cycle	50%
T_r / T_f	80 ns / 40 ns
V_{CLAMP}	15.6 V
Dead time (typ.)	1.2 μ s
I_{o+}/I_{o-} (typ.)	180 mA / 260 mA

Package Options

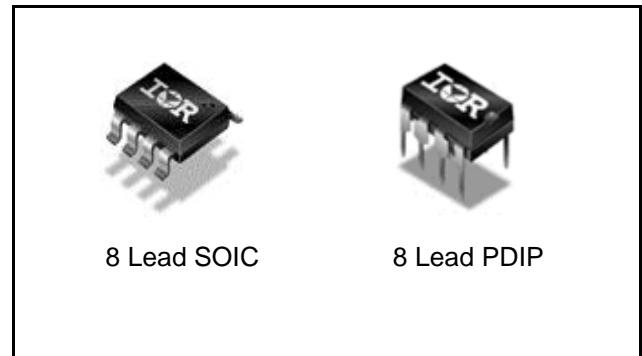

Ordering Information

Base Part Number	Package Type	Standard Pack		Orderable Part Number
		Form	Quantity	
IR25603SPBF	SO8N	Tube	95	IR25603SPBF
IR25603SPBF	SO8N	Tape and Reel	2500	IR25603STRPBF
IR25603PBF	PDIP8	Tube	50	IR25603PBF

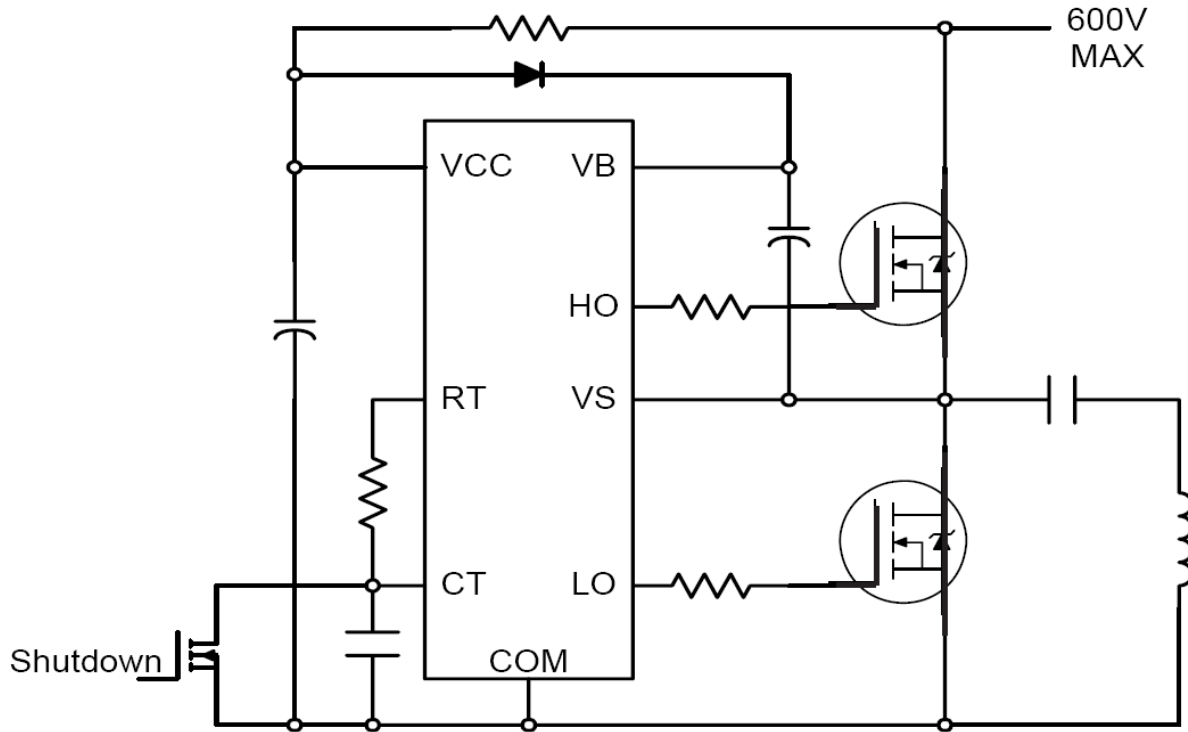
Typical Connection Diagram

Absolute Maximum Ratings

Absolute maximum ratings indicate sustained limits beyond which damage to the device may occur. All voltage parameters are absolute voltages referenced to COM, all currents are defined positive into any lead. The thermal resistance and power dissipation ratings are measured under board mounted and still air conditions.

Symbol	Definition	Min.	Max.	Units	
V_B	High side floating absolute voltage	-0.3	625	V	
V_S	High side floating supply offset voltage	$V_B - 25$	$V_B + 0.3$		
V_{HO}	High side floating output voltage	$V_S - 0.3$	$V_B + 0.3$		
V_{LO}	Low side output voltage	-0.3	$V_{CC} + 0.3$		
V_{RT}	R_T pin voltage	-0.3	$V_{CC} + 0.3$		
V_{CT}	C_T pin voltage	-0.3	$V_{CC} + 0.3$		
I_{CC}	Supply current†	—	25	mA	
I_{RT}	R_T pin current	-5	5		
dVs/dt	Allowable offset supply voltage transient	—	50	V/ns	
P_D	Package power dissipation @ $T_A \leq +25^\circ\text{C}$	8 lead PDIP	—	1	W
		8 lead SOIC	—	0.625	
R_{thJA}	Thermal resistance, junction to ambient	8 lead PDIP	—	125	$^\circ\text{C}/\text{W}$
		8 lead SOIC	—	200	
T_J	Junction temperature	—	150	$^\circ\text{C}$	
T_S	Storage temperature	-55	150		
T_L	Lead temperature (soldering, 10 seconds)	—	300		

Recommended Operating Conditions

For proper operation the device should be used within the recommended conditions. The V_S offset rating is tested with all supplies biased at 15V differential.

Symbol	Definition	Min.	Max.	Units
V_B	High side floating supply absolute voltage	$V_{CC} - 0.7$	V_{CLAMP}	V
V_S	Steady state high side floating supply offset voltage	††	600	
V_{CC}	Supply voltage	10	V_{CLAMP}	mA
I_{CC}	Supply current	†††	5	
T_A	Ambient temperature	-40	125	$^\circ\text{C}$

† This IC contains a zener clamp structure between the chip V_{CC} and COM which has a nominal breakdown voltage of 15.6V. Please note that this supply pin should not be driven by a DC, low impedance power source greater than the V_{CLAMP} specified in the Electrical Characteristics section.

†† Care should be taken to avoid output switching conditions where the V_S node flies inductively below ground by more than 5V.

††† Enough current should be supplied to the V_{CC} pin of the IC to keep the internal 15.6V zener diode clamping the voltage at this pin.

Recommended Component Values

Symbol	Component	Min.	Max.	Units
R_T	Timing resistor value	10	—	$k\Omega$
C_T	C_T pin capacitor value	330	—	μF

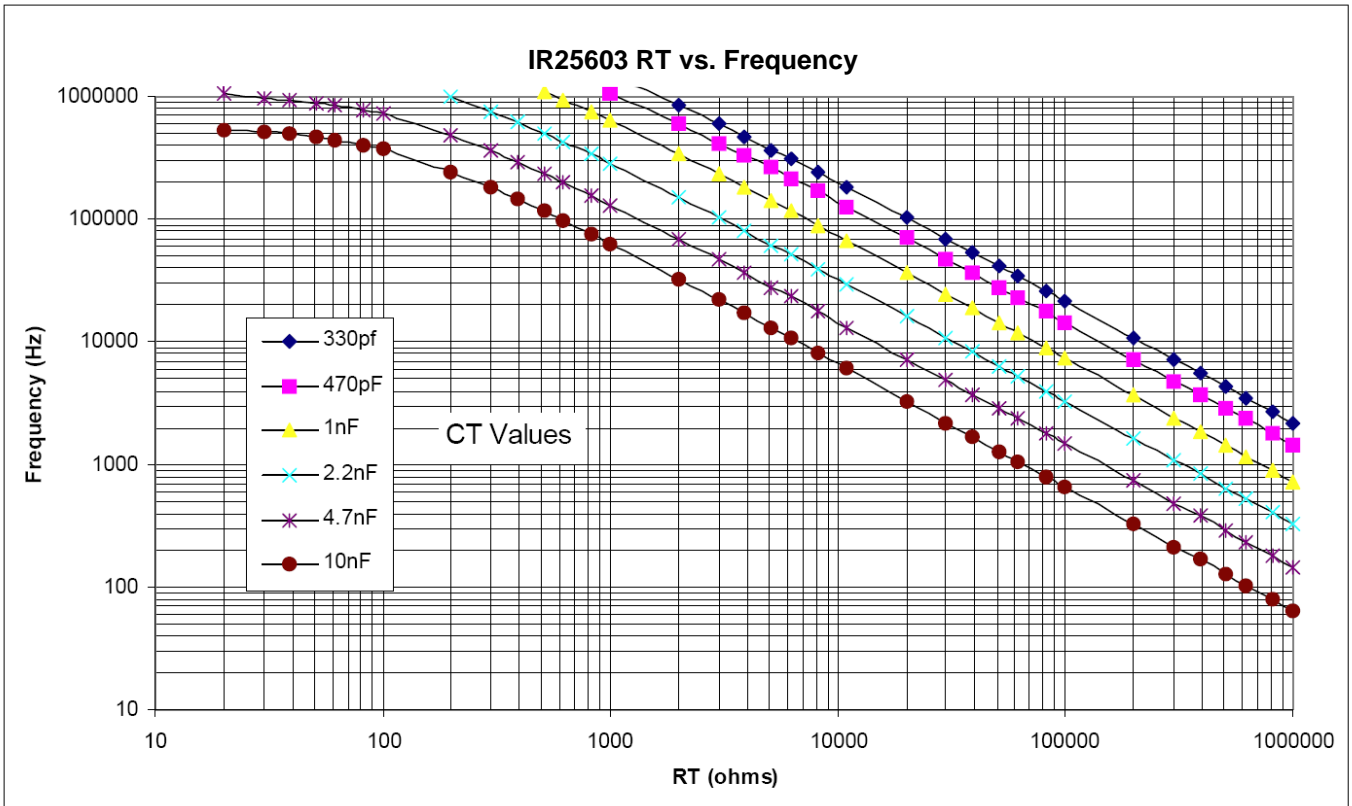

Electrical Characteristics

V_{BIAS} (V_{CC} , V_{BS}) = 12V, C_L = 1000 pF, C_T = 1nF and T_A = 25°C unless otherwise specified.

Low Voltage Supply Characteristics						
Symbol	Definition	Min.	Typ.	Max.	Units	Test Conditions
V_{CCUV+}	V_{CC} supply undervoltage positive going threshold	8.1	9.0	9.9	V	
V_{CCUV-}	V_{CC} supply undervoltage negative going threshold	7.2	8.0	8.8		
V_{CCUVH}	V_{CC} undervoltage hysteresis	0.5	1.0	1.5		
I_{QCCUV}	Micropower startup V_{CC} supply current	—	75	150	μ A	$V_{CC} \leq V_{CCUV-}$
I_{QCC}	Quiescent V_{CC} supply current	—	500	950		
V_{CLAMP}	V_{CC} zener clamp voltage	14.4	15.6	16.8	V	$I_{CC} = 5mA$
Floating Supply Characteristics						
Symbol	Definition	Min.	Typ.	Max.	Units	Test Conditions
I_{QBSUV}	Micropower startup V_{BS} supply current	—	0	10	μ A	$V_{CC} \leq V_{CCUV-}$
I_{QBS}	Quiescent V_{BS} supply current	—	30	50		
V_{BSMIN}	Minimum required V_{BS} voltage for proper functionality from R_T to HO	—	4.0	5.0	V	$V_{CC} = V_{CCUV+} + 0.1V$
I_{LK}	Offset supply leakage current	—	—	50	μ A	$V_B = V_S = 600V$
Oscillator I/O Characteristics						
Symbol	Definition	Min.	Typ.	Max.	Units	Test Conditions
f_{OSC}	Oscillator frequency	19.4	20	20.6	kHz	$R_T = 36.9k\Omega$
		94	100	106		$R_T = 7.43k\Omega$
d	R_T pin duty cycle	48	50	52	%	$f_O < 100kHz$
I_{CT}	C_T pin current	—	0.001	1.0	μ A	
I_{CTUV}	UV-mode C_T pin pull down current	0.3	0.7	1.2	mA	$V_{CC} = 7V$
V_{CT+}	Upper C_T ramp voltage threshold	—	8	—	V	
V_{CT-}	Lower C_T ramp voltage threshold	—	4	—		
V_{CTSD}	C_T voltage shutdown threshold	1.8	2.1	2.4		
V_{RT+}	High-level R_T output voltage, $V_{CC} - V_{RT}$	—	10	50	mV	$I_{RT} = 100 \mu A$
		—	100	300		$I_{RT} = 1mA$
V_{RT-}	Low-level R_T output voltage	—	10	50		$I_{RT} = 100 \mu A$
		—	100	300		$I_{RT} = 1mA$
V_{RTUV}	UV-mode R_T output voltage	—	0	100		$V_{CC} \leq V_{CCUV-}$
V_{RTSD}	SD-Mode R_T output voltage, $V_{CC} - V_{RT}$	—	10	50		$I_{RT} = 100 \mu A$, $V_{CT} = 0V$
		—	10	300		$I_{RT} = 1mA$, $V_{CT} = 0V$

Electrical Characteristics (cont.)

Gate Driver Output Characteristics						
Symbol	Definition	Min.	Typ.	Max.	Units	Test Conditions
VOH	High level output voltage, $V_{BIAS} - V_O$	—	0	100	mV	$I_O = 0A$
VOL	Low-level output voltage, V_O	—	0	100		$I_O = 0A$
VOL_UV	UV-mode output voltage, V_O	—	0	100		$I_O = 0A$ $V_{CC} \leq V_{CCUV-}$
t_r	Output rise time	—	80	150	ns	
t_f	Output fall time	—	45	100		
t_{sd}	Shutdown propagation delay	—	660	—		
t_d	Output dead time (HO or LO)	0.75	1.20	1.65	μs	
I_{O+}	Output source current	—	180	—	mA	
I_{O-}	Output sink current	—	260	—		

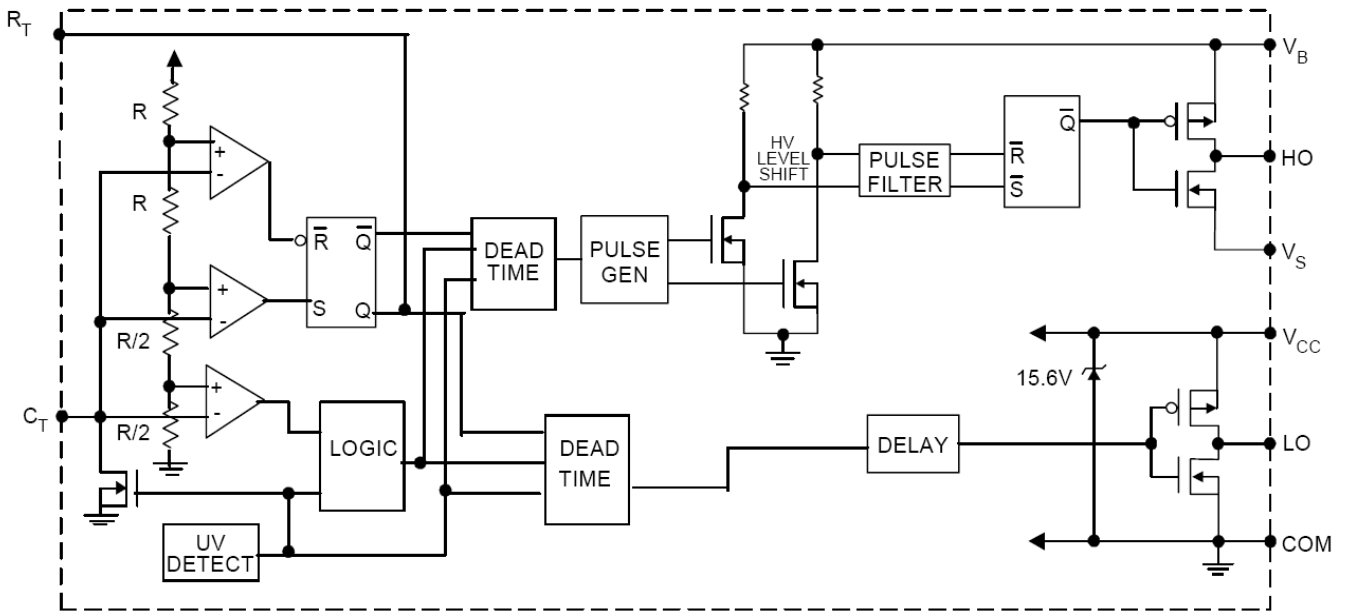
Functional Block Diagram

Lead Definitions

Symbol	Description
V _{CC}	Logic and internal gate drive supply voltage
R _T	Oscillator timing resistor input
C _T	Oscillator timing capacitor input
COM	IC power and signal ground
LO	Low side gate driver output
V _S	High voltage floating supply return
HO	High side gate driver output
V _B	High side gate driver floating supply

Lead Assignments

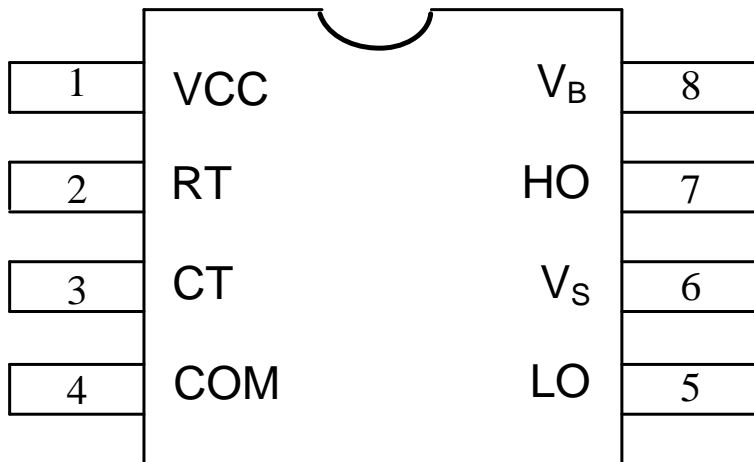

Application Information and Additional Details

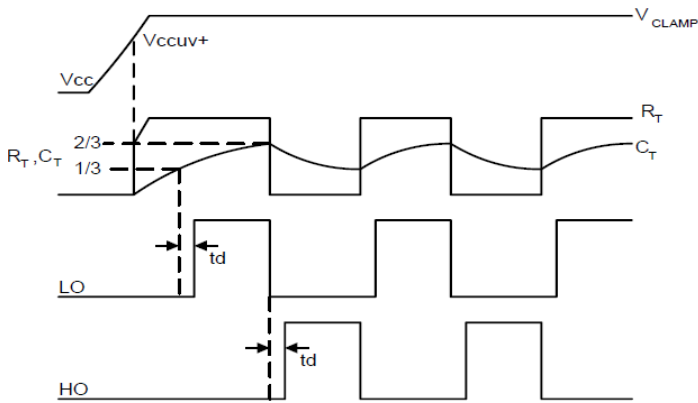

Figure 1. Input/Output Timing Diagram

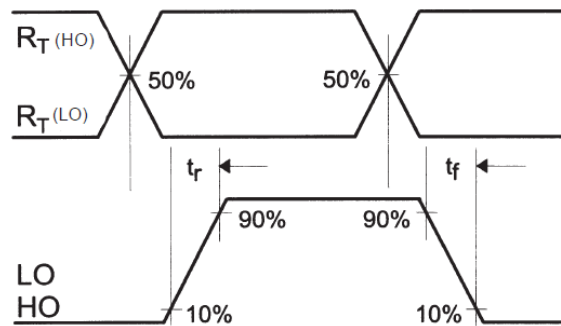

Figure 2. Switching Time Waveform Definitions

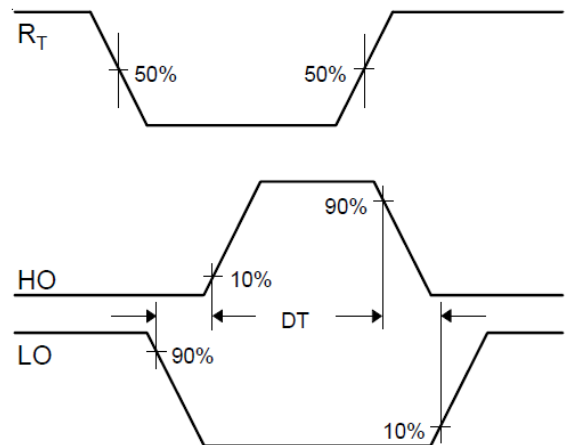
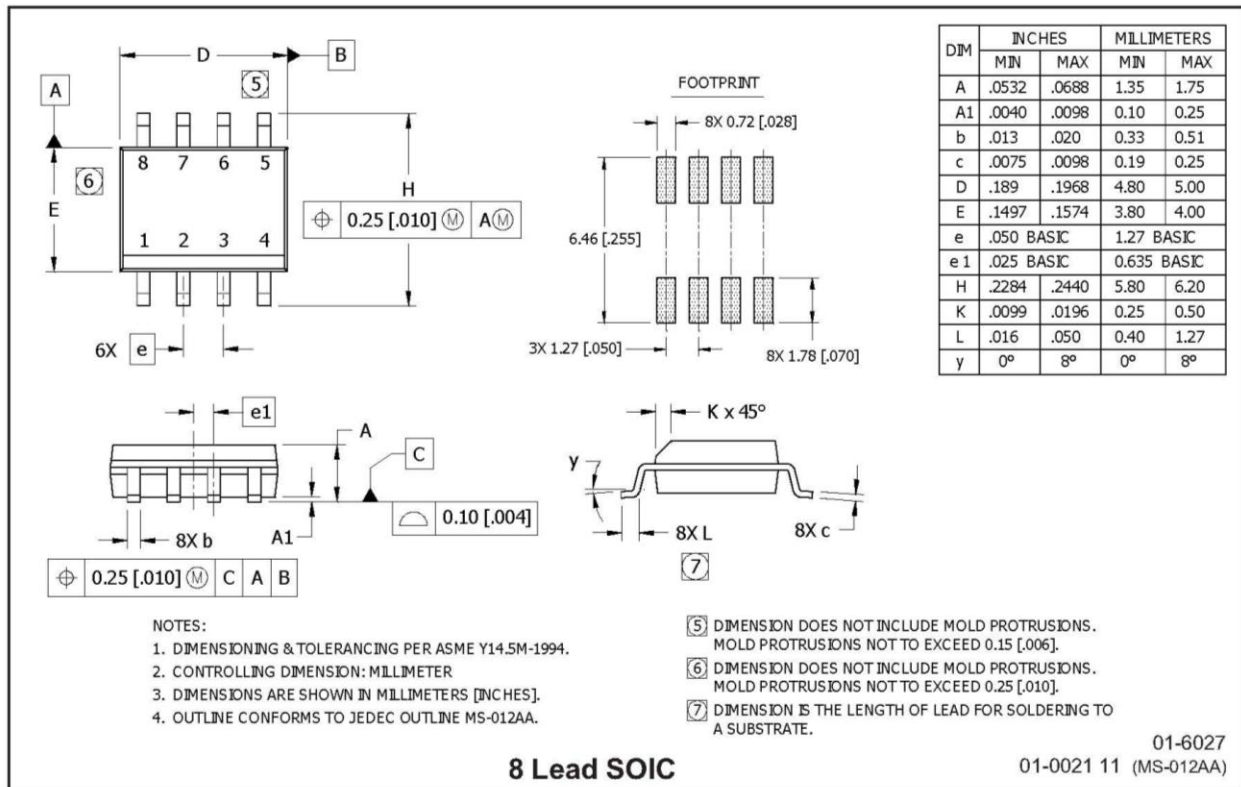
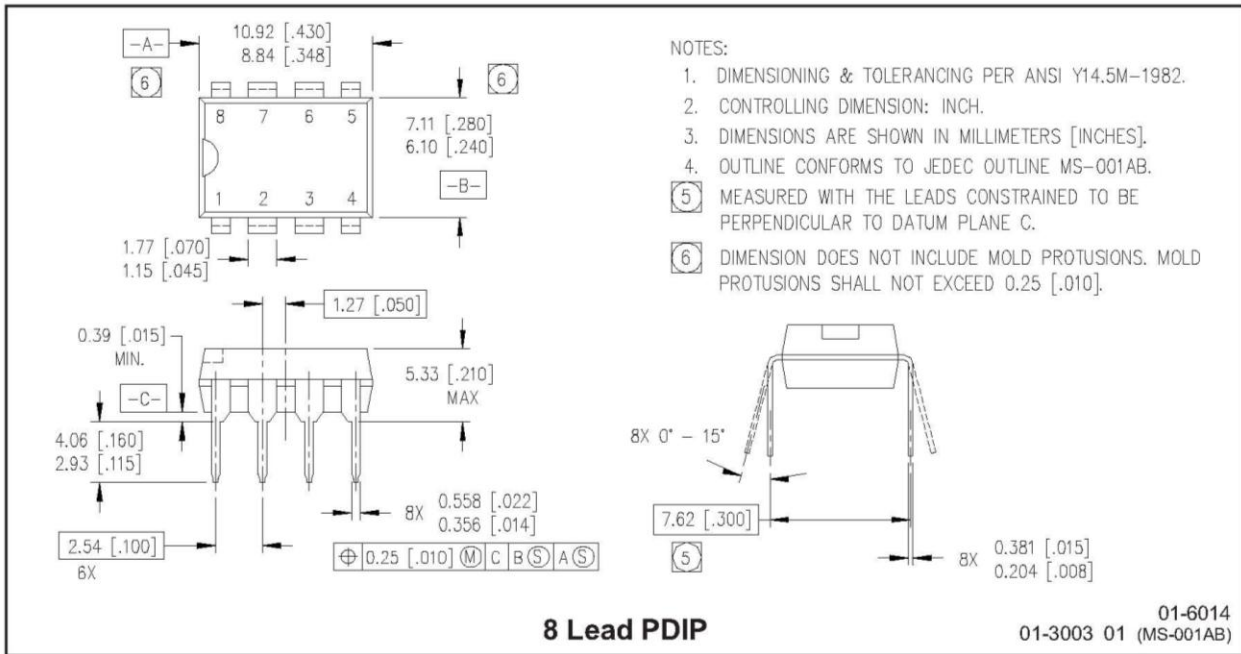
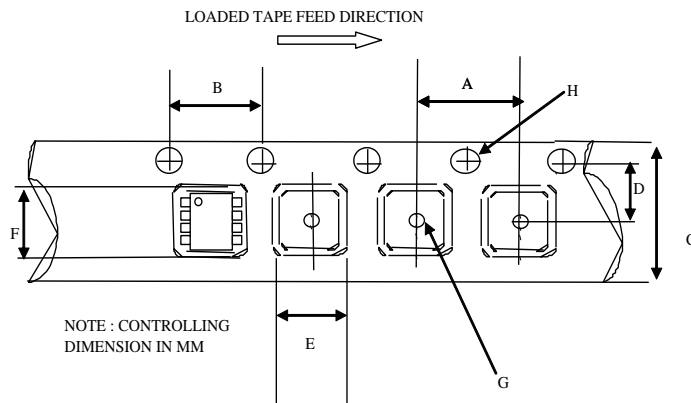

Figure 3. Deadtime Waveform Definitions

Package Details

Tape and Reel Details, SO8N



CARRIER TAPE DIMENSION FOR 8SOICN

Code	Metric		Imperial	
	Min	Max	Min	Max
A	7.90	8.10	0.311	0.318
B	3.90	4.10	0.153	0.161
C	11.70	12.30	0.46	0.484
D	5.45	5.55	0.214	0.218
E	6.30	6.50	0.248	0.255
F	5.10	5.30	0.200	0.208
G	1.50	n/a	0.059	n/a
H	1.50	1.60	0.059	0.062

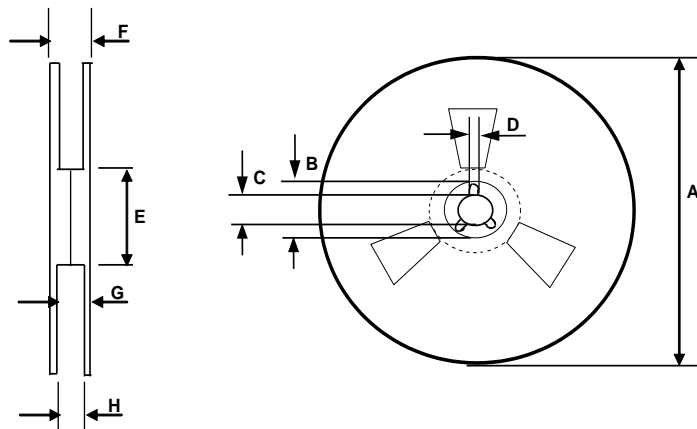

REEL DIMENSIONS FOR 8SOICN

Code	Metric		Imperial	
	Min	Max	Min	Max
A	329.60	330.25	12.976	13.001
B	20.95	21.45	0.824	0.844
C	12.80	13.20	0.503	0.519
D	1.95	2.45	0.767	0.096
E	98.00	102.00	3.858	4.015
F	n/a	18.40	n/a	0.724
G	14.50	17.10	0.570	0.673
H	12.40	14.40	0.488	0.566

Part Marking Information

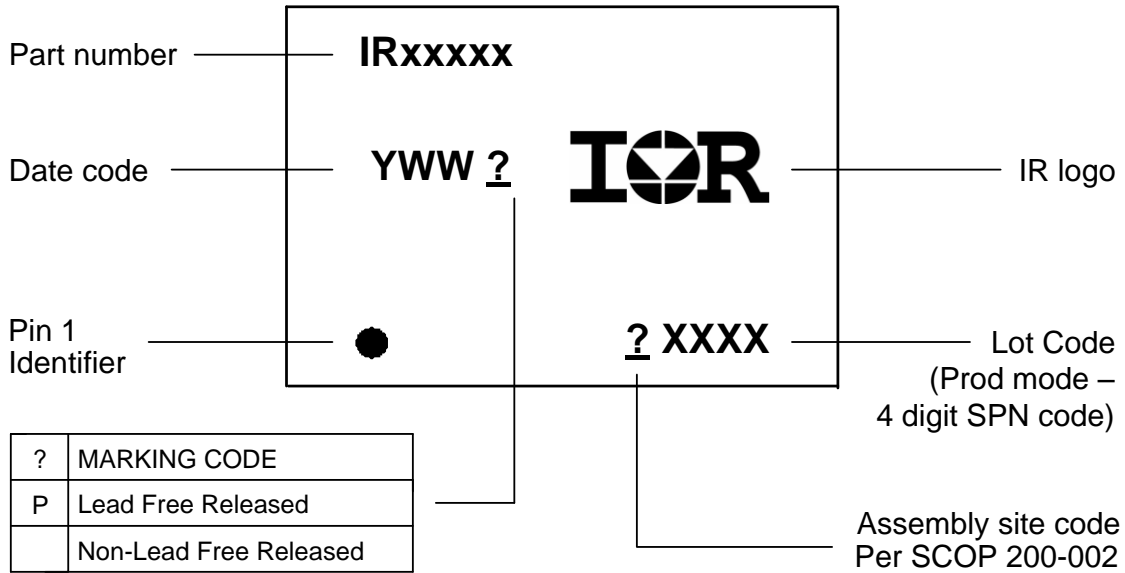

Qualification Information[†]

Qualification Level	Industrial ^{††} (per JEDEC JESD 47)	
	Comments: This family of ICs has passed JEDEC's Industrial qualification. IR's Consumer qualification level is granted by extension of the higher Industrial level.	
Moisture Sensitivity Level	SOIC8N	MSL2 ^{†††} (per IPC/JEDEC J-STD 020)
	PDIP8	Not applicable (non-surface mount package style)
RoHS Compliant	Yes	

† Qualification standards can be found at International Rectifier's web site <http://www.irf.com/>

†† Higher qualification ratings may be available should the user have such requirements. Please contact your International Rectifier sales representative for further information.

††† Higher MSL ratings may be available for the specific package types listed here. Please contact your International Rectifier sales representative for further information.

The information provided in this document is believed to be accurate and reliable. However, International Rectifier assumes no responsibility for the consequences of the use of this information. International Rectifier assumes no responsibility for any infringement of patents or of other rights of third parties which may result from the use of this information. No license is granted by implication or otherwise under any patent or patent rights of International Rectifier. The specifications mentioned in this document are subject to change without notice. This document supersedes and replaces all information previously supplied.

For technical support, please contact IR's Technical Assistance Center
<http://www.irf.com/technical-info/>

WORLD HEADQUARTERS:
 233 Kansas St., El Segundo, California 90245
 Tel: (310) 252-7105

Компания «Life Electronics» занимается поставками электронных компонентов импортного и отечественного производства от производителей и со складов крупных дистрибьюторов Европы, Америки и Азии.

С конца 2013 года компания активно расширяет линейку поставок компонентов по направлению коаксиальный кабель, кварцевые генераторы и конденсаторы (керамические, пленочные, электролитические), за счёт заключения дистрибьюторских договоров

Мы предлагаем:

- Конкурентоспособные цены и скидки постоянным клиентам.
- Специальные условия для постоянных клиентов.
- Подбор аналогов.
- Поставку компонентов в любых объемах, удовлетворяющих вашим потребностям.
- Приемлемые сроки поставки, возможна ускоренная поставка.
- Доставку товара в любую точку России и стран СНГ.
- Комплексную поставку.
- Работу по проектам и поставку образцов.
- Формирование склада под заказчика.
- Сертификаты соответствия на поставляемую продукцию (по желанию клиента).
- Тестирование поставляемой продукции.
- Поставку компонентов, требующих военную и космическую приемку.
- Входной контроль качества.
- Наличие сертификата ISO.

В составе нашей компании организован Конструкторский отдел, призванный помогать разработчикам, и инженерам.

Конструкторский отдел помогает осуществить:

- Регистрацию проекта у производителя компонентов.
- Техническую поддержку проекта.
- Защиту от снятия компонента с производства.
- Оценку стоимости проекта по компонентам.
- Изготовление тестовой платы монтаж и пусконаладочные работы.



Тел: +7 (812) 336 43 04 (многоканальный)

Email: org@lifeelectronics.ru