

B41 4-Channel RF Relays

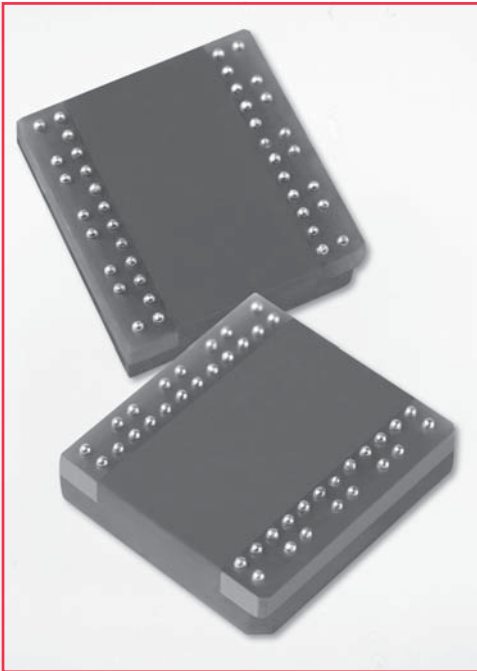

Ball Grid Array 4-Channel Relays

The B41 is four independent form A channels in one planar quad package. Coto's Ball Grid Array (BGA) construction offers a breakthrough in reed relay performance. This patented technology¹ allows for shorter RF paths in a controlled 50 Ω environment to minimize signal attenuation. The designer is now able to switch or pass signals with wider bandwidth and faster rise time than alternative technologies. This is particularly important in Mixed Signal IC testers. This four-in-one BGA packaging allows relays to be integrated easily on boards designed for surface mount processing.

Series Features

- ◆ Planar BGA Surface Mount
- ◆ Ability to pass GHz signals
- ◆ Rise time < 45 pSec
- ◆ ~50 Ω Characteristic Impedance
- ◆ Low Capacitance
- ◆ Patented Design¹

Applications

- ◆ IC Testers
- ◆ In-Line Relay Testers
- ◆ Memory Testers
- ◆ Mixed Signal Testers
- ◆ High Bandpass Applications

Top View

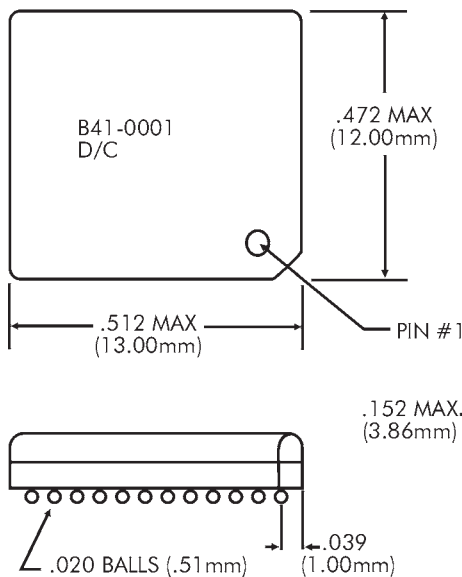

Top View Ball Pattern

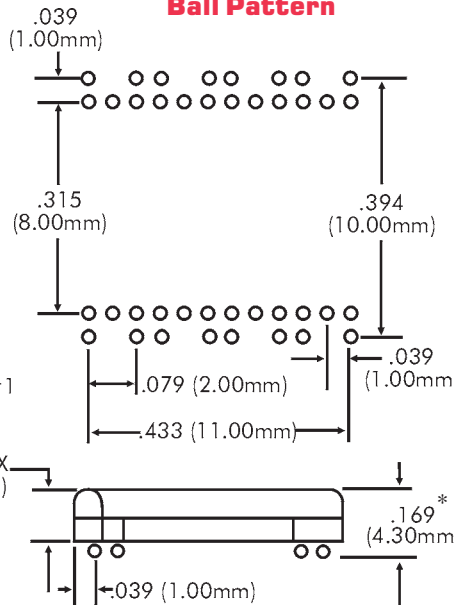

Top View Schematic

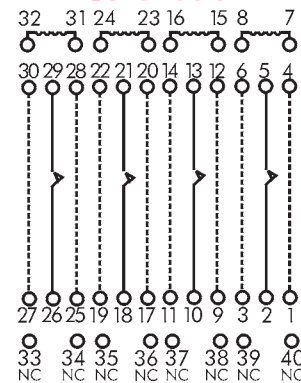

Dimensions in Inches (mm)
METRIC DIMENSIONS GOVERN
General Dimensional Tolerance:
± .006 (0.15)

* Dimensions shown are before soldering.

B41 RECEIVER BOARD PAD LAYOUT

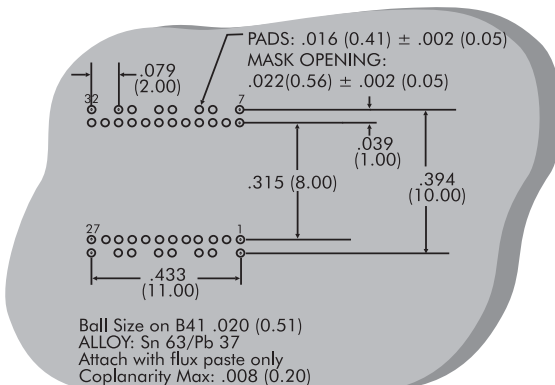

Ordering Information

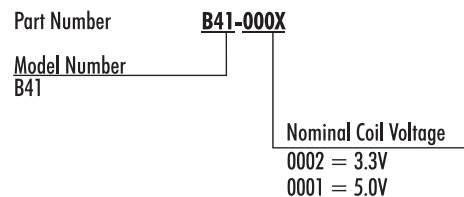

Notes:

¹ Protected by one or more of the following US Patents: 6025768, 6052045, 6294971, 6683518, RE38381 and other foreign patents.

B41 4-Channel RF Relays

Test Parameters	Conditions ^{1,2}	Min	B41		Units
			Typ	Max	
Coil Resistance	3.3V Coil	49.5	55.0	60.5	Ω
Nominal Voltage			3.3	4.0	Volts DC
Must Operate Voltage				2.4	Volts DC
Must Release Voltage		0.4			Volts DC
Coil Resistance	5V Coil	144.0	160.0	176.0	Ω
Nominal Voltage			5.0	6.0	Volts DC
Must Operate Voltage				3.8	Volts DC
Must Release Voltage		0.4			Volts DC
Switching Voltage	Max DC/Peak AC			125	Volts
Switching Current				0.25	Amps
Carry Current (Continuous)	Switch and Shield			0.5	Amps
Contact Rating (Resistive Load)	Resistive Load			3.0	Watts
Life Expectancy	Signal Switching ³		1000		x 10 ⁹ Ops
	Resistive Load ³		1		x 10 ⁶ Ops
	Other Load Conditions ³				Consult Factory
Static Contact Resistance (initial)	0.05VDC / 10mA			0.125	Ω
Dynamic Contact Resistance (initial)	0.5V / 10mA 100 Hz, 1.5 mSec			0.150	Ω
Insulation Res	All Isolated Pins	10 ¹⁰	10 ¹²		Ω
Capacitance	Across Contacts		0.2		pF
Capacitance	Open Contact to Coil		0.3		pF
Capacitance	Closed Contact to Coil		0.5		pF
Dielectric Strength	Across Contacts		150		V (DC/Pk AC)
	Contact to Coil		1000		V (DC/Pk AC)
	Contact To Shield		1000		V (DC/Pk AC)
	Between Contacts of		1000		V (DC/Pk AC)
	Adjacent Channels		1000		V (DC/Pk AC)
Operate Time (including bounce)	Nominal Voltage coil drive @ 30 Hz, square wave		100	200	μSec
Release Time (Si diode damped)			30	50	μSec
RF Insertion Loss ⁴	-3 dB roll-off frequency	8.0			GHz
RF Inter-Channel Isolation	Signal isolation between adjacent closed channels, 1GHz test signal	40.0			dB
Signal Rise Time (10% - 90%)				45	pSec
Magnetic Interaction ⁵	Between adjacent channels			16	%

NOTES:

¹All parameters specified per EIA/NARM standards for dry reed relays, # RS-421 and RS-436, if a suitable parametric standard exists.

²Unless otherwise noted, all parameters are specified at 25°C and 40% RH.

³Life expectancies based on characteristic life (63.2% failure) calculated from the 2-parameter Weibull distribution. Contact resistance >2.0Ω defines end of life.

⁴Frequency at which the difference between output and input signal amplitude exceeds -3dB.

⁵Maximum increase in operate voltage for any channel when all channel coils are driven at nominal coil voltage and with the same drive polarity.

ENVIRONMENTAL RATINGS:

Storage Temperature: -35°C to +100°C.

Operating Temperature: -20°C to +85°C.

Vibration: sinusoidal vibration with an amplitude of 10G over a 10Hz to 2000Hz frequency range shall neither cause a closed channel activated at the nominal coil voltage to open, nor an open channel to close. Max Soldering Temperature: 438°F(226°C) for 1 minute dwell time. Temperature measured at a relay ball termination.

Moisture sensitive component. Handle as J-STD-020B level 5a.

Компания «Life Electronics» занимается поставками электронных компонентов импортного и отечественного производства от производителей и со складов крупных дистрибьюторов Европы, Америки и Азии.

С конца 2013 года компания активно расширяет линейку поставок компонентов по направлению коаксиальный кабель, кварцевые генераторы и конденсаторы (керамические, пленочные, электролитические), за счёт заключения дистрибьюторских договоров

Мы предлагаем:

- Конкурентоспособные цены и скидки постоянным клиентам.
- Специальные условия для постоянных клиентов.
- Подбор аналогов.
- Поставку компонентов в любых объемах, удовлетворяющих вашим потребностям.
- Приемлемые сроки поставки, возможна ускоренная поставка.
- Доставку товара в любую точку России и стран СНГ.
- Комплексную поставку.
- Работу по проектам и поставку образцов.
- Формирование склада под заказчика.
- Сертификаты соответствия на поставляемую продукцию (по желанию клиента).
- Тестирование поставляемой продукции.
- Поставку компонентов, требующих военную и космическую приемку.
- Входной контроль качества.
- Наличие сертификата ISO.

В составе нашей компании организован Конструкторский отдел, призванный помогать разработчикам, и инженерам.

Конструкторский отдел помогает осуществить:

- Регистрацию проекта у производителя компонентов.
- Техническую поддержку проекта.
- Защиту от снятия компонента с производства.
- Оценку стоимости проекта по компонентам.
- Изготовление тестовой платы монтаж и пусконаладочные работы.



Тел: +7 (812) 336 43 04 (многоканальный)

Email: org@lifeelectronics.ru