

# AN1026: Si70xx Temperature Sensor Designer's Guide

This designer's guide describes the Si70xx family of temperature sensor products in a variety of different applications.

The Si7050/1/3/4/5 temperature sensors are supplied in a 3 x 3 mm 6 pin QFN package and support the supply voltage range of 1.9 to 3.6 V. The Si7057/8/9 are supplied in a 6-pin 2 x 2 mm package and support the the supply range of 1.67 to 1.98 V. Refer to the data sheets for detailed pin descriptions, register summaries, and timing details.

Some information in this designers guide is also applicable to the Si70xx temperature and humidity sensors. See "[AN607: Si70xx Humidity and Temperature Sensor Designer's Guide](#)" for more information.

The architecture of the Si70xx temperature sensors is shown in the general block diagram below:

## KEY POINTS

- Thermal Mass and Thermal Resistance
- Thermal Model for a Sensor on a Paddle
- Compensating for Heating and Thermal Response Time for Ambient Measurements
- Core Body Temperature Measurement



## 1. Introduction

The Si70xx temperature sensors work by measuring the  $V_{be}$  of an on chip transistor at two currents in a precise ratio to measure temperature. The resulting voltage is digitized, calibrated and linearized such that after conversion the temperature can be easily calculated.

Thus the temperature being measured is the temperature of the die within the Si70xx package. This die is mounted on a metal lead frame. It is useful to think of the leadframe as the thermal input to the die since the thermal resistance from the paddle to die is quite low (a few  $^{\circ}\text{C}/\text{W}$ ) while the thermal resistance through the top of the package is quite high (over 1000  $^{\circ}\text{C}/\text{watt}$  for convective heat transfer).

Depending on part number and conversion time, the Si70xx parts will measure the temperature of the sensing transistor in a time window of less than 1 ms up to about 10 ms. As temperature is not a quantity that can easily change quickly, this measurement can be considered to be an instantaneous snap shot of the die temperature that is taken once the I<sup>2</sup>C command to measure temperature has completed.

## 2. Thermal Mass and Thermal Resistance

When the IC is soldered down, it becomes thermally connected to the printed circuit board on which it is mounted. The printed circuit board is, in turn, thermally connected to the system it is mounted within. The time constant to respond to changes in ambient air temperature depends on the effective thermal mass the device is connected to as well as the effective thermal resistance. If the entire system (such as a thermostat) can be expected to go up or down in temperature along with the ambient it is measuring, then separating the sensor from the system is not necessary, but response time will generally be slow. A general model for this is shown in the following figure.

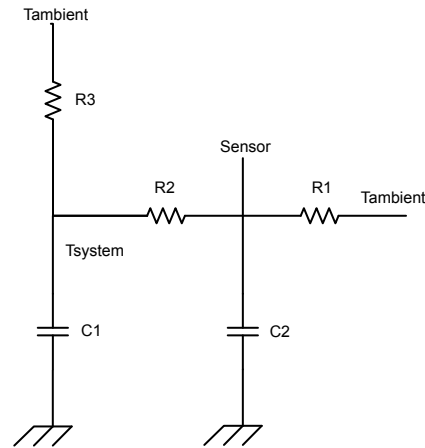

**Figure 2.1. General Thermal Model for Sensor Placement**

If the system has a large thermal mass (C1), or other internal heat sources, the thermal resistance from the sensor to the system (R2) should be much larger than the thermal resistance of the sensor to ambient (R1). For rapid response, the thermal mass connected to the sensor (C2) should be minimized. A practical example of this along with some specific numbers is discussed in "Thermal Model for a Sensor on a Paddle".

### 3. Thermal Model for a Sensor on a Paddle

To illustrate some considerations for separating the sensor from the system, consider the following practical example of the sensor on a 3 cm x 3 cm PCB connected by a 1 cm wide piece of PCB material 3 cm long:

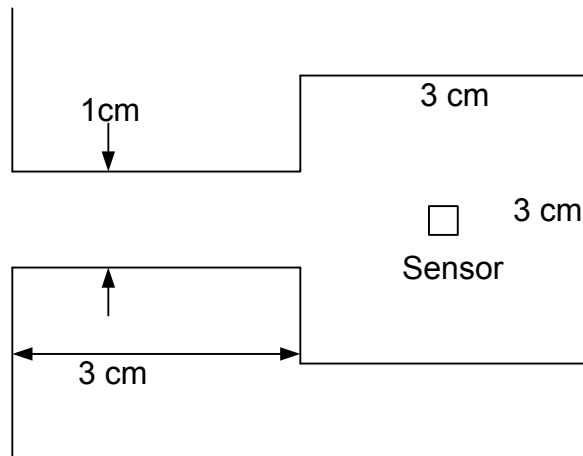

Figure 3.1. Sensor on a 3x3 cm PCB

A thermal model for the above-depicted scenario is shown in [Figure 2.1 General Thermal Model for Sensor Placement on page 2](#).

The thermal impedance to air for a standard FR4 PCB is about 1000 °C/W per cm<sup>2</sup> of PCB area. With two sides exposed to the ambient, a total of 18 cm<sup>2</sup> is connected to the ambient. This makes R1 55.5 °C/W. The mass of 9 cm<sup>2</sup> of PCB material is about 2.5 g (the specific gravity of FR4 is 1850 kg/m<sup>3</sup> and assuming 1.5 mm thickness) and the specific heat capacity of PCB material is 0.6 J/(g·C), so the heat capacity is 1.5 J/C. The time constant:

$$\tau = R1 \times C2 = 55.5 \left( \frac{C}{W} \right) \times 1.5 \left( \frac{J}{C} \right) = 83 \text{ seconds}$$

This time constant is independent of the PCB area—more area means lower thermal impedance but higher thermal mass. To improve the time constant beyond this, thinner PCB material would have to be used, or there would need to be fins or airflow to reduce the thermal impedance. Turning our attention to R2 the thermal conductivity of FR4 material in plane is around 1 Watt/meter·°C. So, for the example of the connection of the sensor area to the rest of the system by 1 cm wide, 3 cm long, 1.5 mm thick FR4:

$$\text{conductance} = \text{thermal conductivity} \times \left( \frac{\text{area}}{\text{length}} \right) = 1 \left( \frac{\text{Watt}}{\text{meter} \cdot \text{C}} \right) \times 10^{-2} \left( \frac{\text{meter}}{\text{cm}} \right) \times 1 \text{cm} \times \frac{0.15 \text{cm}}{3 \text{cm}} = 0.05 \times 10^{-2} \left( \frac{W}{\text{C}} \right)$$

The thermal impedance (1/conductance) is 2000 °C/W (this is R2). This is assuming minimal copper routing on the connector material. With this design since R2 is 36 times R1, so the system heating will have a fairly minor effect. For example if the system heating is 10 °C the sensor temperature would only increase 0.3 °C. If more thermal connection is tolerable the connector area could be made shorter or wider or the PCB area the sensor is connector to could be made smaller. This example was intended to illustrate the thermal design considerations for good response to ambient conditions and insulation from the system. In some cases, it is not possible to place the sensor in sufficient thermal contact with the environment to shield it from the thermal mass and heat sources in the system. In this case, it is often possible to compensate for the system by placing an additional temperature sensor in the system. However, in all cases, the thermal contact of the sensor to the environment should be maximized, and the thermal contact of the sensor to the rest of the system should be minimized.

## 4. Compensating for Heating and Thermal Response Time for Ambient Measurements

### Case 1: Estimating System Temperature Heating

In some cases, it is not possible to mount the temperature sensor so that it is completely away from heat sources and placed so that it will respond to temperature changes as rapidly as possible.

The simplest compensation for heating is to characterize the temperature rise of a system and subtract that rise to get the ambient temperature. In some cases this might not work well because the system heats gradually when powered and may have several states which produce different amounts of heating.

If the system can be characterized by a simple time constant such that:

$$\Delta T = \Delta T_0 + (T_1 - \Delta T_0) \times \left(1 - e^{-\frac{t-t_0}{\tau}}\right)$$

Where  $\Delta T_0$  is the delta T at the last state change, and time is calculated as time elapsed since the state change. Where  $\Delta T_0$  at power application and  $T_1$  is the rise associated with the current state.

System Temperature can be approximated as:

$$T_{system} = T_{ambient} + \Delta T$$

### Case 2: Estimating Ambient Temperature when System Temperature is Known

If  $R_2$  is not small such that the sensor can be at some temperature between the system and ambient then.

$$\frac{T_{system} - T_{sensor}}{R_2} + \frac{T_{ambient} - T_{sensor}}{R_1} = C_2 \times \frac{d(T_{sensor})}{dt}$$

Rewriting and solving for ambient temperature:

$$T_{ambient} = T_{sensor} + \frac{R_1}{R_2} \times (T_{sensor} - T_{system}) + R_1 \times C_2 \times \frac{d(T_{sensor})}{dt}$$

So, if  $T_{system}$  is known from a separate temperature sensor or can be approximated based on how long the system has been powered in a given state, and the other thermal parameters  $R_1$ ,  $R_2$  and  $C_2$  can be determined from calculation or curve fitting, then, it is possible to project the ambient temperature as above.

An issue with the above approach is taking the derivative of  $T_{sensor}$ . If measurements are closely spaced (say one second apart) then changes in sensor temperature will be small and the derivative term is noisy. This can be addressed by making the time between measurements longer, but in this case fluctuations that occur in the longer times are missed. A better approach is to approximate the derivative by a least mean squares fit to a line.

The general equation for the slope with N points is:

$$m = \frac{N \times \sum(x \times y) - \sum x \sum y}{N \times \sum x^2 - (\sum x)^2}$$

This can be simplified by considering the N time points (x) to be equally spaced and numbered from  $-(N-1)/2$  to  $(N-1)/2$  for example for 15 points numbered from -7 to +7 including zero as a point. In this case the sum of x is zero and:

$$m = \frac{\sum(x \times y)}{\sum x^2}$$

If a fixed number of points is used the sum of  $x^2$  is constant and if the factors  $R_1$  and  $C_2$  are determined by curve fitting the sum of  $x^2$  can even be lumped in to that curve fitting constant.

## 5. Core Body Temperature Measurement

The high accuracy of the Si70xx temperature sensors and in particular the Si7051 (which is  $\pm 0.1$  °C in the human body temperature range) make these parts natural for skin temperature measurement.

Skin temperature may be of interest by itself but normally what is of more interest is “core temperature” which is most accurately measured by insertion of a probe into a body cavity (oral or rectal). At other places on the body, the skin temperature will be between the core temperature and ambient temperature.

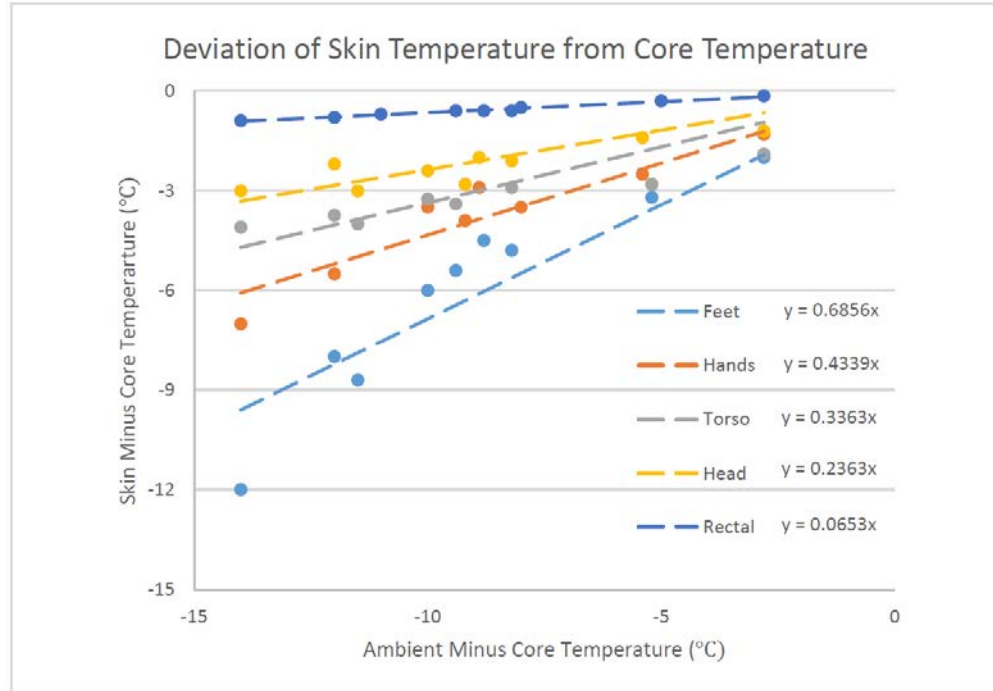

**Figure 5.1. Deviation of Skin Temperature from Core Temperature as a Function of Ambient Temperature for a Nude Person<sup>1</sup>**

1. Olsen, B.W., Thermal Comfort, Technical Review, Bruel and Kjaer, 1982

So, for the case of projecting core temperature from skin temperature, the location of the temperature measurement device must be considered. As a simple approximation a nominal ambient temperature (e.g., 23 °C) can be used and the correction can be derived from the above chart.

If the actual ambient temperature is known, this can be factored in.

Another option is to use a temperature sensor well coupled to the skin and a second temperature sensor coupled to the ambient as well as possible. The core temperature can then be estimated from the skin temperature and the gradient from skin temperature to ambient temperature. Rewriting the equations from the above graph:

$$T_{core} = T_{skin} + \alpha \times (T_{skin} - T_{ambient})$$

Where:

	$\alpha$
Rectal	0.0699
Head	0.3094
Torso	0.5067
Hand	0.7665
Foot	2.1807

It is desirable to place the skin side temperature sensor in good contact with the skin and in a location where the correction for core temperature is not large. The thermal impedance for skin contact is about  $1\text{ }^{\circ}\text{C}/\text{W}\text{-cm}^2$  which is very low compared to convection away from a PCB of about  $1000\text{ }^{\circ}\text{C}/\text{W}\text{-cm}^2$ , so it is generally not difficult to sense skin temperature quickly and accurately.

In a wearable device, accurate projection of  $T_{\text{ambient}}$  is very difficult unless it is possible to access data from a remote sensor. But, if the skin sensor is placed well such that the ambient correction is small this is not critical. PCB material has fairly low thermal conductivity ( $0.1\text{ Watt}/\text{cm}\text{-}^{\circ}\text{C}$ ) and the thermal impedance from PCB to air by convection is quite large ( $1000^{\circ}\text{C}/\text{W}\text{-cm}^2$ ) of surface area so it is important that the ambient side sensor is insulated from the skin side sensor by more than just PCB material. Even the use of cotton or fiberglass insulation is difficult.

Consider the following model:



The thermal conductivity of cotton or fiberglass is in the range of  $0.003$  to  $0.005\text{ Watt}/\text{cm}\text{-}^{\circ}\text{C}$ . This means that, even for a  $1\text{ cm}$  thick insulating layer, the thermal impedance from the skin-side PCB to the ambient side PCB is  $200\text{--}300\text{ }^{\circ}\text{C}/\text{W}$  per  $\text{cm}^2$  of area while convective thermal impedance from the ambient side PCB to the ambient is about  $1000\text{ }^{\circ}\text{C}/\text{W}$  per  $\text{cm}^2$  of area, and the ambient side PCB is not sufficiently well insulated from the skin-side PCB.

It is impractical to further increase the insulation for this kind of arrangement. A better solution is to sense the ambient temperature with a leaded thermistor. In the diagram below, the concept is to embed the ambient sensing thermistor in an aluminum bezel so as to minimize thermal contact to the skin side PCB and maximize thermal contact to the ambient.



Now, the sensors will probably not sense skin temperature and ambient temperature exactly and typical use cases might be different than the above model (i.e., wearing of clothes, exercise, placement of sensor on the body, circulation, etc.) However, with all of these variations, the form of the following equation will still be correct, and the parameter,  $\alpha$ , must be empirically deduced.

$$T_{\text{core}} = T_{\text{skin}} + \alpha \times (T_{\text{skin}} - T_{\text{ambient}})$$

If the sensor can be worn in a way that it senses core temperature fairly well (for example on the forehead or under the arm), then the parameter  $\alpha$  will be small and can be estimated by testing a number of subjects and averaging.

For an ambient temperature sensor that is well coupled to the ambient, the ambient side sensor will react more quickly to the ambient than the skin and there can be some “overshoot” of the projected core temperature. In general, this effect will not be large enough to make a compensation worthwhile especially if the skin side sensor is placed in close proximity to the core temperature.



Smart.  
Connected.  
Energy-Friendly.



**Products**  
[www.silabs.com/products](http://www.silabs.com/products)



**Quality**  
[www.silabs.com/quality](http://www.silabs.com/quality)



**Support and Community**  
[community.silabs.com](http://community.silabs.com)

**Disclaimer**

Silicon Laboratories intends to provide customers with the latest, accurate, and in-depth documentation of all peripherals and modules available for system and software implementers using or intending to use the Silicon Laboratories products. Characterization data, available modules and peripherals, memory sizes and memory addresses refer to each specific device, and "Typical" parameters provided can and do vary in different applications. Application examples described herein are for illustrative purposes only. Silicon Laboratories reserves the right to make changes without further notice and limitation to product information, specifications, and descriptions herein, and does not give warranties as to the accuracy or completeness of the included information. Silicon Laboratories shall have no liability for the consequences of use of the information supplied herein. This document does not imply or express copyright licenses granted hereunder to design or fabricate any integrated circuits. The products are not designed or authorized to be used within any Life Support System without the specific written consent of Silicon Laboratories. A "Life Support System" is any product or system intended to support or sustain life and/or health, which, if it fails, can be reasonably expected to result in significant personal injury or death. Silicon Laboratories products are not designed or authorized for military applications. Silicon Laboratories products shall under no circumstances be used in weapons of mass destruction including (but not limited to) nuclear, biological or chemical weapons, or missiles capable of delivering such weapons.

**Trademark Information**

Silicon Laboratories Inc.®, Silicon Laboratories®, Silicon Labs®, SiLabs® and the Silicon Labs logo®, Bluegiga®, Bluegiga Logo®, Clockbuilder®, CMEMS®, DSPLL®, EFM®, EFM32®, EFR®, Ember®, Energy Micro, Energy Micro logo and combinations thereof, "the world's most energy friendly microcontrollers", Ember®, EZLink®, EZRadio®, EZRadioPRO®, Gecko®, ISOModem®, Precision32®, ProSLIC®, Simplicity Studio®, SiPHY®, Telegesis, the Telegesis Logo®, USBXpress® and others are trademarks or registered trademarks of Silicon Laboratories Inc. ARM, CORTEX, Cortex-M3 and THUMB are trademarks or registered trademarks of ARM Holdings. Keil is a registered trademark of ARM Limited. All other products or brand names mentioned herein are trademarks of their respective holders.



Silicon Laboratories Inc.  
400 West Cesar Chavez  
Austin, TX 78701  
USA

<http://www.silabs.com>



Компания «Life Electronics» занимается поставками электронных компонентов импортного и отечественного производства от производителей и со складов крупных дистрибьюторов Европы, Америки и Азии.

С конца 2013 года компания активно расширяет линейку поставок компонентов по направлению коаксиальный кабель, кварцевые генераторы и конденсаторы (керамические, пленочные, электролитические), за счёт заключения дистрибьюторских договоров

Мы предлагаем:

- Конкурентоспособные цены и скидки постоянным клиентам.
- Специальные условия для постоянных клиентов.
- Подбор аналогов.
- Поставку компонентов в любых объемах, удовлетворяющих вашим потребностям.
- Приемлемые сроки поставки, возможна ускоренная поставка.
- Доставку товара в любую точку России и стран СНГ.
- Комплексную поставку.
- Работу по проектам и поставку образцов.
- Формирование склада под заказчика.
- Сертификаты соответствия на поставляемую продукцию (по желанию клиента).
- Тестирование поставляемой продукции.
- Поставку компонентов, требующих военную и космическую приемку.
- Входной контроль качества.
- Наличие сертификата ISO.

В составе нашей компании организован Конструкторский отдел, призванный помогать разработчикам, и инженерам.

Конструкторский отдел помогает осуществить:

- Регистрацию проекта у производителя компонентов.
- Техническую поддержку проекта.
- Защиту от снятия компонента с производства.
- Оценку стоимости проекта по компонентам.
- Изготовление тестовой платы монтаж и пусконаладочные работы.



Тел: +7 (812) 336 43 04 (многоканальный)

Email: [org@lifeelectronics.ru](mailto:org@lifeelectronics.ru)