

U91 - D1XX - 1X0X - XX

HEAT SINK OPTION

- 0 - NO HEAT SINK, NO CLIP, NO CAGE COVER
- 1 - NO HEAT SINK, NO CLIP, CAGE COVER ATTACHED
- 2 - SQUARE PIN STYLE HEAT SINK (BLACK OXIDE) WITH CLIP
- 5 - ROUND PIN STYLE HEAT SINK (BLACK OXIDE) WITH CLIP
- A - SQUARE PIN STYLE HEAT SINK (NICKEL PLATED) WITH CLIP
- D - ROUND PIN STYLE HEAT SINK (NICKEL PLATED) WITH CLIP
- G - SQUARE PIN STYLE HEAT SINK (CHROMATE PASSIVATION) WITH CLIP
- K - ROUND PIN STYLE HEAT SINK (CHROMATE PASSIVATION) WITH CLIP

KEYING OPTION

- 0 - NO KEY
- 1 - LEFT KEY (INFINIBAND)
- 2 - RIGHT KEY (ETHERNET)

OPTIONAL DUST COVER

- 0 - NO DUST COVER
- D - WITH DUST COVER (SHIPPED BULK IN SAME BOX WITH CAGE & CONNECTOR ASSEMBLY)

MOUNTING SCREWS

- 0 - NO MOUNTING SCREWS SHIPPED
- 1 - WITH MOUNTING SCREWS (M2x4 - 6mm LONG) SHIPPED BULK IN SAME TRAY WITH CAGE ASSEMBLIES

CONTACT PLATING

- 1 - MATING AREA PLATING: 0.76 µm GOLD OVER 2.54 µm OF NICKEL
PRESS FIT TAIL AREA PLATING: 0.76 µm TIN LEAD OVER 2.54 µm OF NICKEL
- 2 - MATING AREA PLATING: 0.38 µm GOLD OVER 2.54 µm OF NICKEL
PRESS FIT TAIL AREA PLATING: 0.76 µm TIN LEAD OVER 2.54 µm OF NICKEL
- 3 - MATING AREA PLATING: 0.76 µm GOLD OVER 1.27 µm TO 3.81 µm OF NICKEL
PRESS FIT TAIL AREA PLATING: 0.381 µm TO 1.52 µm OF MATTE TIN OVER 1.27 µm TO 3.81µm OF NICKEL
(RoHS COMPLIANT PER RoHS DIRECTIVE 2011/65/EU; OPTION 3 ONLY)

PACKAGING

- 1 - TRAY PACKAGING (CAGE & CONNECTOR ASSEMBLY IN SEPARATE TRAYS FROM HEAT SINKS AND CLIPS, IF ORDERED)
- A - TRAY PACKAGING (CAGE & CONNECTOR ASSEMBLY SHIPPED WITH HEAT SINK AND HEAT SINK CLIP ATTACHED)

REVISIONS			
REV.	DESCRIPTION	DATE	APPROVED
A	NEW RELEASE	JAN 21/11	ZLJ
B	3.75 ADDED	FEB 14/11	ZLJ
C	NEW CONTACT PLATING OPTION ADDED	JUL 04/11	ZLJ
D	HEAT SINK OPTION "0" ADDED	JAN 27/12	ZLJ
E	AHSI DESIGNATION ADDED	MAY 16/12	ZLJ
F	DIMENSION 9.3 CORRECTED	JUN 14/12	ZLJ
G	RoHS DIRECTIVE ADDED	DEC 3/12	ZLJ
H	BOT. VIEW ADDED FOR CONN. DETAIL	APR 8/13	ZLJ
J	PRESS FIT HOLE/BEZEL TOL. UPDATED	JUL 23/13	ZLJ
K	DIMENSIONS & TOLERANCES UPDATED	AUG 6/13	ZLJ
L	ADDED REAR CAGE STEP VIEW, SHEET 2	DEC 18/14	A.C

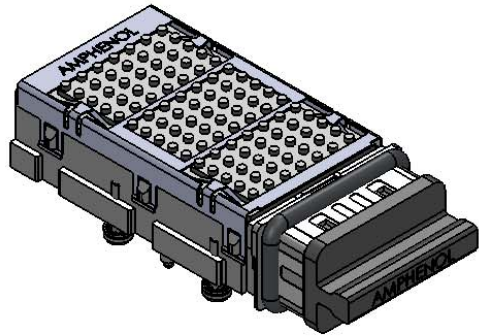

PART # U91-D151-1D0A-11 SHOWN
(CAGE & CONNECTOR ASSEMBLY WITH ROUND PIN HEAT SINK ATTACHED, SCREWS AND DUST COVER ARE SHIPPED BULK)

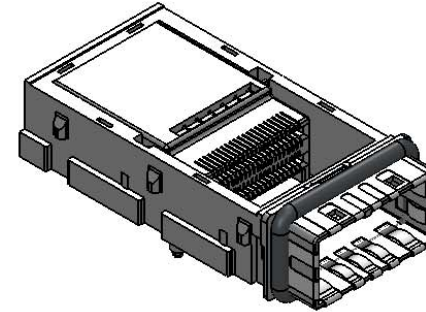

PART # U91-D101-1001-10 SHOWN
(CAGE & CONNECTOR ASSEMBLY WITH NO COVER, NO SCREWS SHIPPED)

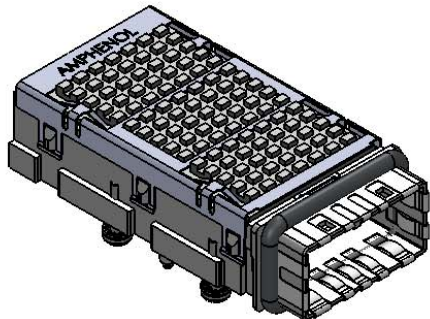

PART # U91-D121-100A-11 SHOWN
(CAGE & CONNECTOR ASSEMBLY WITH SQUARE PIN HEAT SINK ATTACHED, SCREWS ARE SHIPPED BULK)

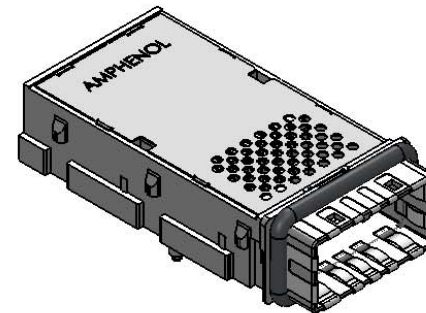

PART # U91-D111-1001-10 SHOWN
(CAGE & CONNECTOR ASSEMBLY NO HEAT SINK, NO SCREWS SHIPPED)

UNLESS OTHERWISE SPECIFIED: DIMENSIONS ARE IN MILLIMETERS TOLERANCES ARE:		APPROVAL	DATE
DECIMALS	ANGLES	DRAWN: ZLJ	JAN 10/11
.X ±0.2	X° ±1°	CHECKED: ZLJ	JAN 10/11
.XX ±0.1	X.X° ±0.5°	GA APPR:	
		ME APPR:	
		DWG APPR: A.G.	JAN 10/11
 DO NOT SCALE DRAWING		ENG. REL. NO.	
		NSCM:	

Amphenol High Speed Interconnects
A Division of Amphenol Corp. www.amphenol-highspeed.com

**CXP
CAGE AND CONNECTOR
ASSEMBLY
(ENHANCED FOOTPRINT)**

SIZE	DWG. NO.	REV
	P-U91-D1XX-1XXX-XX	L
SCALE: 1:1	PROJECT: CXP	SHEET 1 OF 4

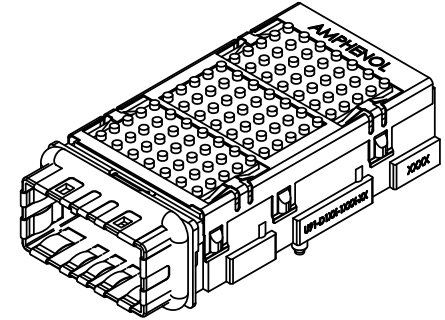
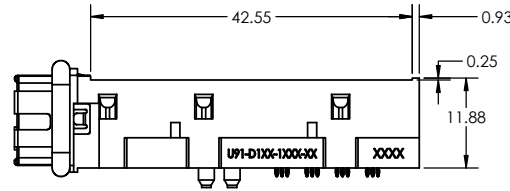
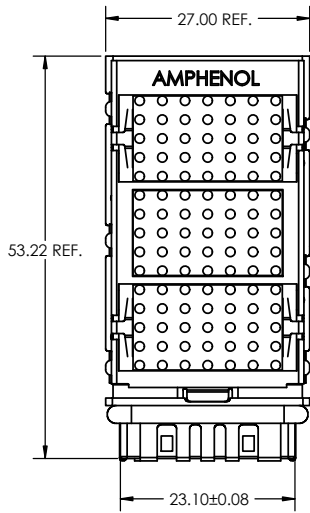

U91-D101-1001-10
SHOWN IN THIS VIEW

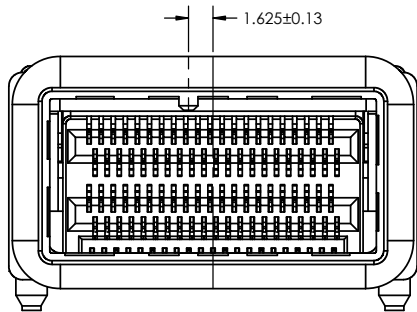
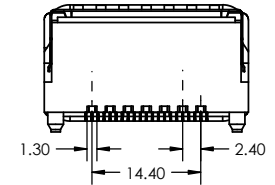
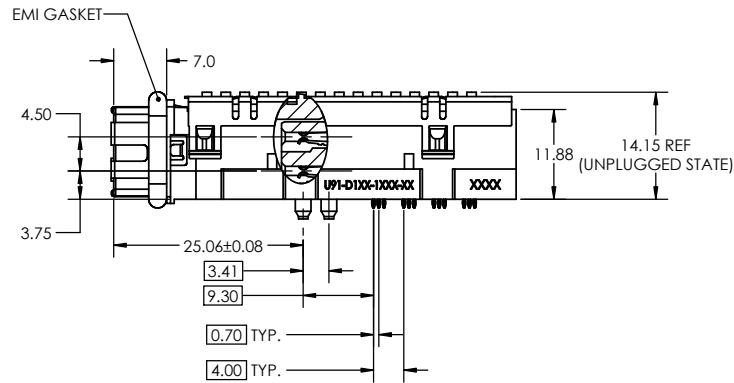
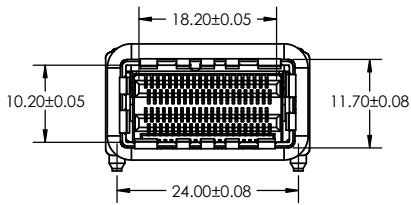

U91-D1X1-1XXX-XX
LEFT KEY SHOWN
EMI SPRING FINGERS
REMOVED FOR CLARITY

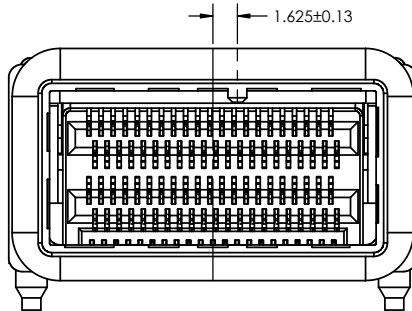

U91-D1X2-1XXX-XX
RIGHT KEY SHOWN
EMI SPRING FINGERS
REMOVED FOR CLARITY

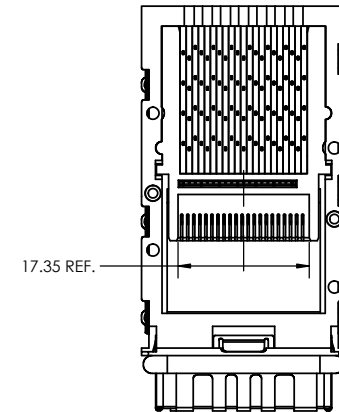

UNLESS OTHERWISE SPECIFIED:
DIMENSIONS ARE IN MILLIMETERS
TOLERANCES ARE:

DECIMALS .X ±0.2
.XX ±0.1

ANGLES X° ±1°
X.X° ±0.5°

APPROVAL	DATE
DRAWN: ZLJ	JAN 10/11
CHECKED: ZLJ	JAN 10/11
QA APPR:	
ME APPR:	
DWG APPR: A.G.	JAN 10/11
ENG. REL. NO.	
NSCM:	

Amphenol High Speed Interconnects
A Division of Amphenol Corp. www.amphenol-highspeed.com

**CXP
CAGE AND CONNECTOR
ASSEMBLY
(ENHANCED FOOTPRINT)**

SIZE	DWG. NO. P-U91-D1XX-1XXX-XX	REV L
SCALE: 2:1	PROJECT: CXP	SHEET 2 OF 4

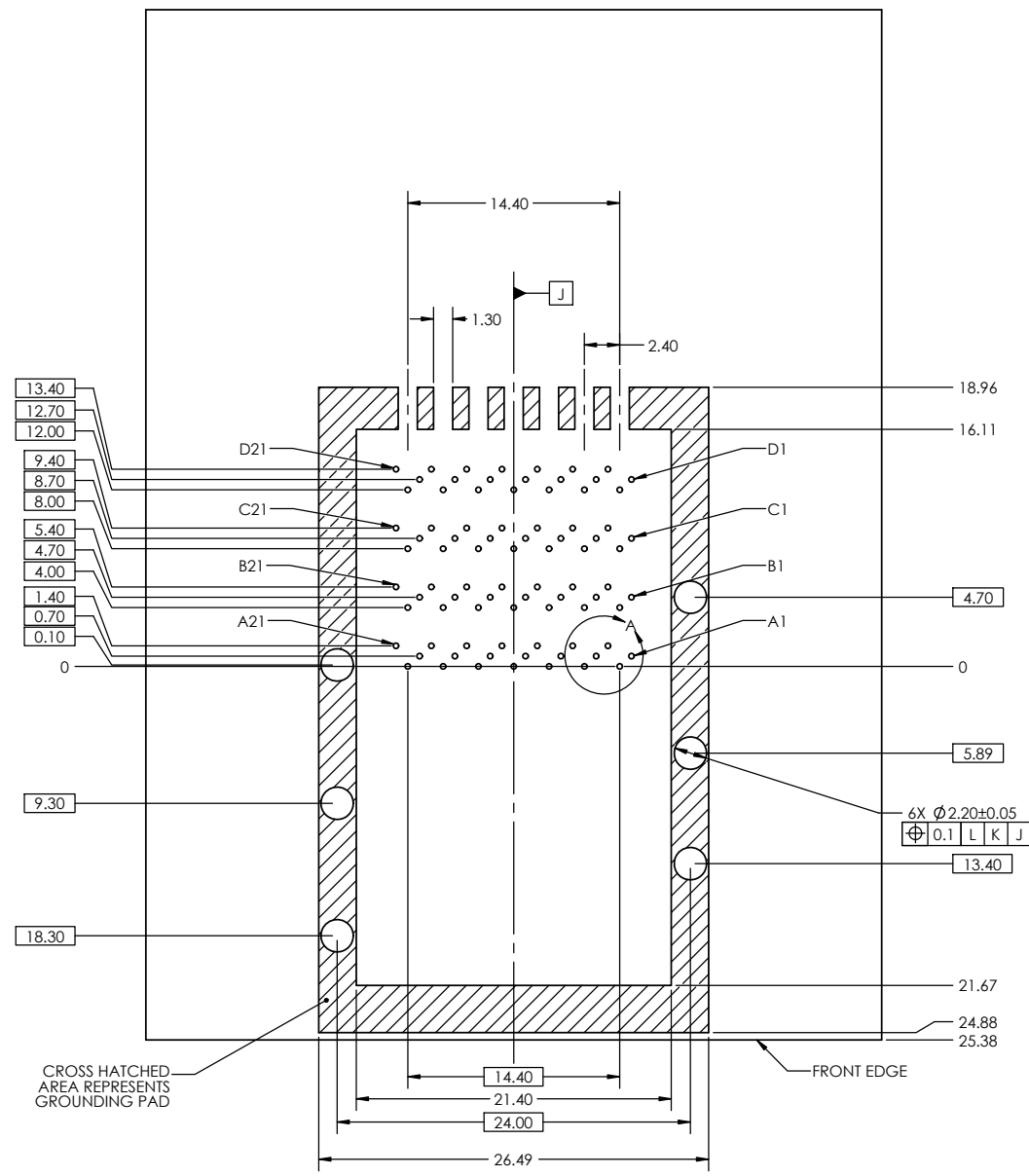

RECOMMENDED **SINGLE MOUNT**
PCB LAYOUT
COMPONENT SIDE SHOWN

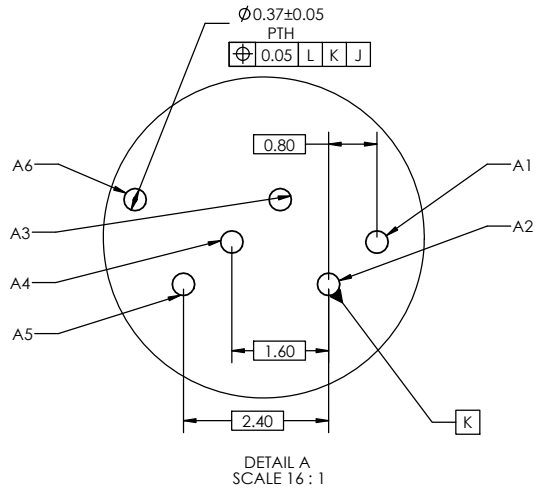
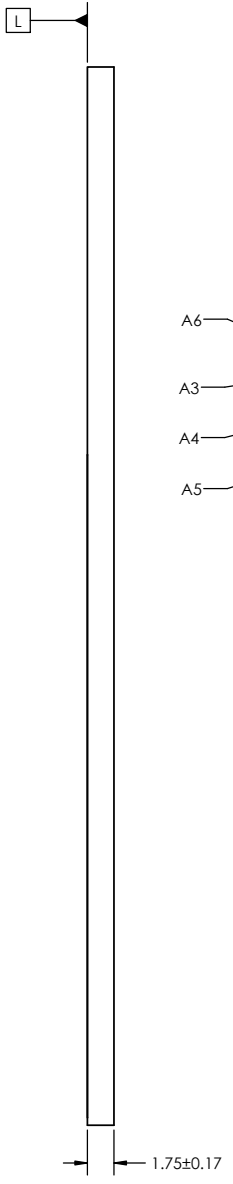

6X Ø2.20±0.05
Ø0.1 L K J

UNLESS OTHERWISE SPECIFIED: DIMENSIONS ARE IN MILLIMETERS TOLERANCES ARE:		APPROVAL	DATE
DECIMALS	ANGLES	DRAWN ZLJ	JAN 10/11
.X ±0.2	X° ±1°	CHECKED ZLJ	JAN 10/11
.XX ±0.1	X.X° ±0.5°	QA APPR.	
		ME APPR.	
		DWG APPR. A.G.	JAN 10/11
 DO NOT SCALE DRAWING		ENG. REL. NO.	
		NSCM:	

Amphenol High Speed Interconnects A Division of Amphenol Corp. www.amphenol-highspeed.com			
CXP CAGE AND CONNECTOR ASSEMBLY (ENHANCED FOOTPRINT)			
SIZE	DWG. NO.	P-U91-D1XX-1XXX-XX	REV L
SCALE: 2:1	PROJECT: CXP	SHEET 3 OF 4	

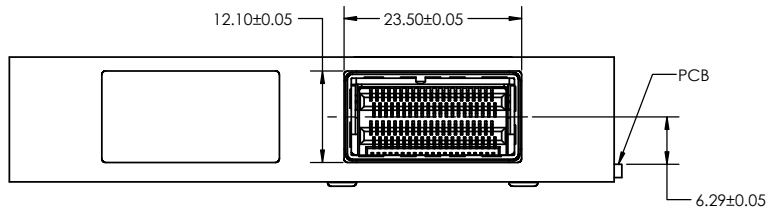

RECOMMENDED PANEL CUTOUT FOR **SINGLE LEVEL** MOUNTING

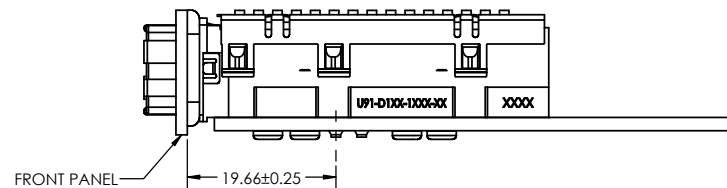
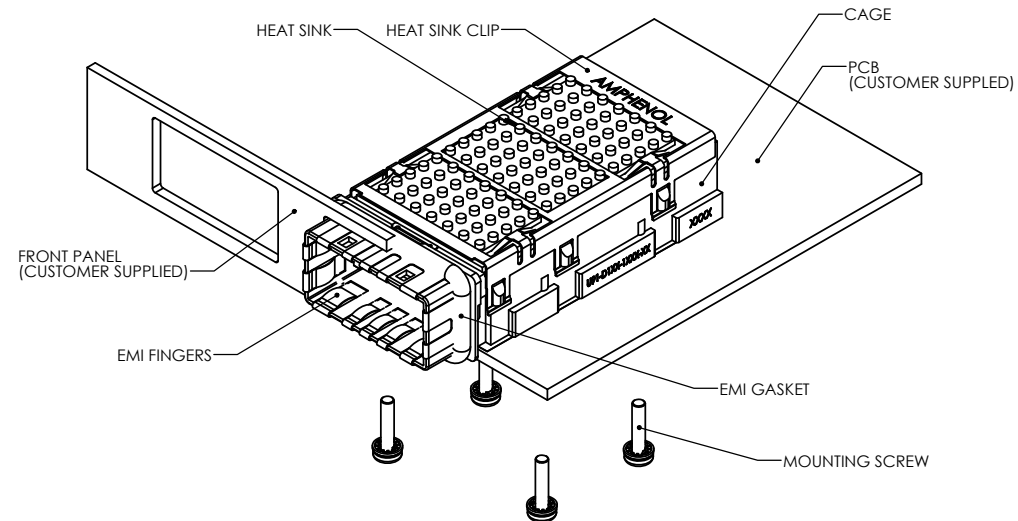
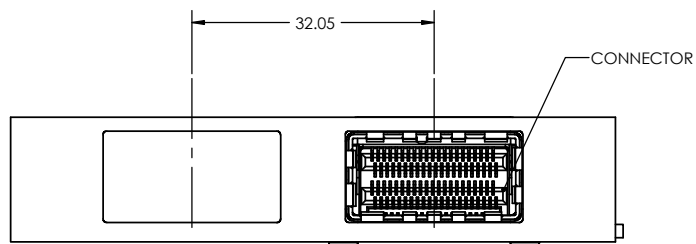

NOTES:

- 1) MATERIAL
 - MAIN CAGE: ZINC DIE CAST SHELL WITH NICKEL PLATING
 - EMI GASKET: CONDUCTIVE ELASTOMER
 - HEAT SINK CLIP: STAINLESS STEEL
 - CAGE COVER: STAINLESS STEEL (OPTION WITH CAGE COVER ONLY SHOWN ON SHEET ONE)
 - HEAT SINK: ALUMINUM, FOR PLATING INFO. SEE SHEET ONE
 - EMI FINGERS: PHOSPHOR BRONZE WITH NICKEL PLATING
 - MOUNTING SCREWS: AISI 1010 STEEL
 - CONNECTOR HOUSING: LCP
 - CONTACTS: PHOSPHOR BRONZE, FOR PLATING INFO. SEE SHEET ONE
- 2) CONNECTOR AND CAGE ASSEMBLY IS RoHS COMPLIANT

UNLESS OTHERWISE SPECIFIED: DIMENSIONS ARE IN MILLIMETERS TOLERANCES ARE:	APPROVAL	DATE	Amphenol High Speed Interconnects A Division of Amphenol Corp. www.amphenol-highspeed.com		
	DRAWN: ZLJ	JAN 10/11			
	CHECKED: ZLJ	JAN 10/11	CXP CAGE AND CONNECTOR ASSEMBLY (ENHANCED FOOTPRINT)		
	GA APPR:				
ME APPR:			SIZE	DWG. NO. P-U91-D1XX-1XXX-XX	REV L
DWG APPR: A.G.	JAN 10/11		SCALE: 2:1	PROJECT: CXP	SHEET 4 OF 4
DO NOT SCALE DRAWING	ENG. REL. NO.				
	NSCM:				

Компания «Life Electronics» занимается поставками электронных компонентов импортного и отечественного производства от производителей и со складов крупных дистрибьюторов Европы, Америки и Азии.

С конца 2013 года компания активно расширяет линейку поставок компонентов по направлению коаксиальный кабель, кварцевые генераторы и конденсаторы (керамические, пленочные, электролитические), за счёт заключения дистрибьюторских договоров

Мы предлагаем:

- Конкуренспособные цены и скидки постоянным клиентам.
- Специальные условия для постоянных клиентов.
- Подбор аналогов.
- Поставку компонентов в любых объемах, удовлетворяющих вашим потребностям.
- Приемлемые сроки поставки, возможна ускоренная поставка.
- Доставку товара в любую точку России и стран СНГ.
- Комплексную поставку.
- Работу по проектам и поставку образцов.
- Формирование склада под заказчика.
- Сертификаты соответствия на поставляемую продукцию (по желанию клиента).
- Тестирование поставляемой продукции.
- Поставку компонентов, требующих военную и космическую приемку.
- Входной контроль качества.
- Наличие сертификата ISO.

В составе нашей компании организован Конструкторский отдел, призванный помогать разработчикам, и инженерам.

Конструкторский отдел помогает осуществить:

- Регистрацию проекта у производителя компонентов.
- Техническую поддержку проекта.
- Защиту от снятия компонента с производства.
- Оценку стоимости проекта по компонентам.
- Изготовление тестовой платы монтаж и пусконаладочные работы.



Тел: +7 (812) 336 43 04 (многоканальный)

Email: org@lifeelectronics.ru