

NB2304A

3.3 V Zero Delay Clock Buffer

The NB2304A is a versatile, 3.3 V zero delay buffer designed to distribute high-speed clocks in PC, workstation, datacom, telecom and other high-performance applications. It is available in an 8 pin package. The part has an on-chip PLL which locks to an input clock presented on the REF pin. The PLL feedback is required to be driven to FBK pin, and can be obtained from one of the outputs. The input-to-output propagation delay is guaranteed to be less than 250 ps, and the output-to-output skew is guaranteed to be less than 200 ps.

The NB2304A has two Banks of two outputs each. Multiple NB2304A devices can accept the same input clock and distribute it. In this case, the skew between the outputs of the two devices is guaranteed to be less than 500 ps.

The NB2304A is available in two different configurations (Refer to NB2304A Configurations Table). The NB2304Ax1* is the base part, where the output frequencies equal the reference if there is no counter in the feedback path. The NB2304Ax1H is the high-drive version of the -1 and the rise and fall times on this device are much faster.

The NB2304Ax2 allows the user to obtain REF, 1/2 X and 2X frequencies on each output Bank. The exact configuration and output frequencies depend on which output drives the feedback pin.

Features

- Zero Input – Output Propagation Delay, Adjustable by Capacitive Load on FBK Input
- Multiple Configurations – Refer to NB2304A Configurations Table
- Input Frequency Range: 15 MHz to 133 MHz
- Multiple Low-Skew Outputs
- Output-Output Skew < 200 ps
- Device-Device Skew < 500 ps
- Two Banks of Four Outputs
- Less than 200 ps Cycle-to-Cycle Jitter (-1, -1H, -5H)
- Available in Space Saving, 8 pin 150 mil SOIC Package
- 3.3 V Operation
- Advanced 0.35 μ CMOS Technology
- Industrial Temperature Available
- These are Pb-Free Devices

*x = C for Commercial; I for Industrial.



ON Semiconductor®

<http://onsemi.com>

MARKING DIAGRAM*



SOIC-8
D SUFFIX
CASE 751

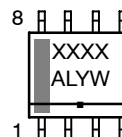

XXXX = Device Code
A = Assembly Location
L = Wafer Lot
Y = Year
W = Work Week
▪ = Pb-Free Package

*For additional marking information, refer to Application Note AND8002/D.

ORDERING INFORMATION

See detailed ordering and shipping information in the package dimensions section on page 9 of this data sheet.

NB2304A

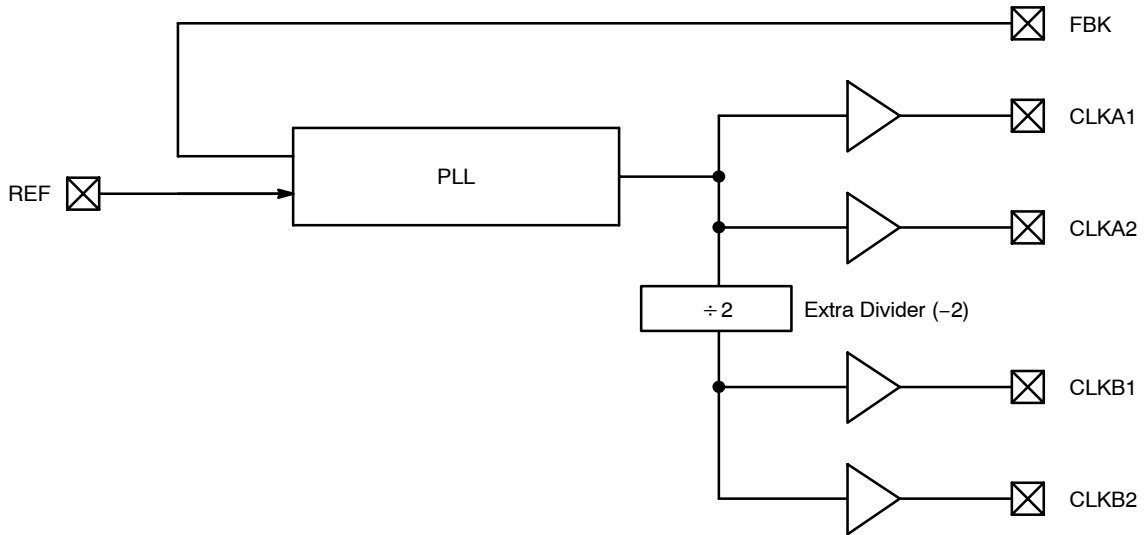

Figure 1. Basic Block Diagram
(see Figures 11 and 12 for device specific Block Diagrams)

Table 1. CONFIGURATIONS (x = C for Commercial; I for Industrial)

Device	Feedback From	Bank A Frequency	Bank B Frequency
NB2304Ax1	Bank A or Bank B	Reference	Reference
NB2304Ax1H	Bank A or Bank B	Reference	Reference
NB2304Ax2	Bank A	Reference	Reference ÷ 2
NB2304Ax2	Bank B	2 X Reference	Reference

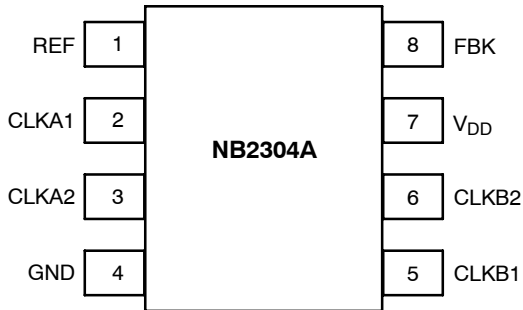

Figure 2. Pin Configuration

Table 2. PIN DESCRIPTION

Pin #	Pin Name	Description
1	REF (Note 1)	Input reference frequency, 5 V tolerant input.
2	CLKA1 (Note 2)	Buffered clock output, Bank A.
3	CLKA2 (Note 2)	Buffered clock output, Bank A.
4	GND	Ground.
5	CLKB1 (Note 2)	Buffered clock output, Bank B.
6	CLKB2 (Note 2)	Buffered clock output, Bank B.
7	V _{DD}	3.3 V supply.
8	FBK	PLL feedback input.

1. Weak pulldown.
2. Weak pulldown on all outputs.

NB2304A

Table 3. MAXIMUM RATINGS

Parameter	Min	Max	Unit
Supply Voltage to Ground Potential	-0.5	+7.0	V
DC Input Voltage (Except REF)	-0.5	$V_{DD} + 0.5$	V
DC Input Voltage (REF)	-0.5	7	V
Storage Temperature	-65	+150	°C
Maximum Soldering Temperature (10 sec)		260	°C
Junction Temperature		150	°C
Static Discharge Voltage (per MIL-STD-883, Method 3015)		> 2000	V

Maximum ratings are those values beyond which device damage can occur. Maximum ratings applied to the device are individual stress limit values (not normal operating conditions) and are not valid simultaneously. If these limits are exceeded, device functional operation is not implied, damage may occur and reliability may be affected.

Table 4. OPERATING CONDITIONS FOR COMMERCIAL AND INDUSTRIAL TEMPERATURE DEVICES

Parameter	Description	Min	Max	Unit
V_{DD}	Supply Voltage	3.0	3.6	V
T_A	Operating Temperature (Ambient Temperature)	Commercial Industrial	0 70 85	°C
C_L	Load Capacitance, 15 MHz to 100 MHz		30	pF
C_L	Load Capacitance, from 100 MHz to 133 MHz		15	pF
C_{IN}	Input Capacitance (Note 3)		7	pF

3. Applies to both REF Clock and FBK.

Table 5. ELECTRICAL CHARACTERISTICS FOR COMMERCIAL TEMPERATURE DEVICES

Parameter	Description	Test Conditions	Min	Max	Unit
V_{IL}	Input LOW Voltage			0.8	V
V_{IH}	Input HIGH Voltage		2.0		V
I_{IL}	Input LOW Current	$V_{IN} = 0\text{ V}$		50.0	μA
I_{IH}	Input HIGH Current	$V_{IN} = V_{DD}$		100.0	μA
V_{OL}	Output LOW Voltage	$I_{OL} = 8\text{ mA} (-1, -2)$ $I_{OL} = 12\text{ mA} (-1H)$		0.4	V
V_{OH}	Output HIGH Voltage	$I_{OH} = -8\text{ mA} (-1, -2)$ $I_{OH} = -12\text{ mA} (-1H)$	2.4		V
I_{DD}	Supply Current	Unloaded outputs 100 MHz REF Select inputs at V_{DD} or GND		45	mA
		Unloaded outputs, 66 MHz REF (-1, -2)		32	
		Unloaded outputs, 33 MHz REF (-1, -2)		18	

NB2304A

Table 6. SWITCHING CHARACTERISTICS FOR COMMERCIAL TEMPERATURE DEVICES

Parameter	Description	Test Conditions	Min	Typ	Max	Unit
t ₁	Output Frequency	30 pF load (all devices)	15		133	MHz
		15 pF load (-1, -2)	15		133.3	
	Duty Cycle = (t ₂ / t ₁) * 100 (all devices)	Measured at 1.4 V, F _{OUT} = 66.66 MHz 30 pF load	40.0	50.0	60.0	%
	Measured at 1.4 V, F _{OUT} ≤ 50 MHz 15 pF load	45.0	50.0	55.0		
t ₃	Output Rise Time (-1, -2)	Measured between 0.8 V and 2.0 V 30 pF load			2.20	ns
		Measured between 0.8 V and 2.0 V 15 pF load			1.50	
	Output Rise Time (-1H)	Measured between 0.8 V and 2.0 V 30 pF load			1.50	
t ₄	Output Fall Time (-1, -2)	Measured between 2.0 V and 0.8 V 30 pF load			2.20	ns
		Measured between 2.0 V and 0.8 V 15 pF load			1.50	
	Output Fall Time (-1H)	Measured between 2.0 V and 0.8 V 30 pF load			1.25	
t ₅	Output-to-Output Skew on same Bank (-1, -2)	All outputs equally loaded			200	ps
	Output-to-Output Skew (-1H)	All outputs equally loaded			200	
	Output Bank A-to-Output Bank B Skew (-1)	All outputs equally loaded			200	
	Output Bank A-to-Output Bank B Skew (-2)	All outputs equally loaded			400	
t ₆	Delay, REF Rising Edge to FBK Rising Edge	Measured at V _{DD} /2		0	±250	ps
t ₇	Device-to-Device Skew	Measured at V _{DD} /2 on the FBK pins of the device		0	500	ps
t ₈	Output Slew Rate	Measured between 0.8 V and 2.0 V using Test Circuit #2	1			V/ns
t _J	Cycle-to-Cycle Jitter (-1, -1H)	Measured at 66.67 MHz, loaded outputs, 15 pF load			175	ps
		Measured at 66.67 MHz, loaded outputs, 30 pF load			200	
		Measured at 133.3 MHz, loaded outputs, 15 pF load			100	
	Cycle-to-Cycle Jitter (-2)	Measured at 66.67 MHz, loaded outputs, 30 pF load			400	ps
		Measured at 66.67 MHz, loaded outputs, 15 pF load			375	
t _{LOCK}	PLL Lock Time	Stable power supply, valid clock presented on REF and FBK pins			1.0	ms

NB2304A

Table 7. ELECTRICAL CHARACTERISTICS FOR INDUSTRIAL TEMPERATURE DEVICES

Parameter	Description	Test Conditions	Min	Max	Unit
V _{IL}	Input LOW Voltage			0.8	V
V _{IH}	Input HIGH Voltage		2.0		V
I _{IL}	Input LOW Current	V _{IN} = 0 V		50.0	μA
I _{IH}	Input HIGH Current	V _{IN} = V _{DD}		100.0	μA
V _{OL}	Output LOW Voltage	I _{OL} = 8 mA (-1, -2) I _{OL} = 12 mA (-1H)		0.4	V
V _{OH}	Output HIGH Voltage	I _{OH} = -8 mA (-1, -2) I _{OH} = -12 mA (-1H)	2.4		V
I _{DD}	Supply Current	Unloaded outputs 100 MHz REF Select inputs at V _{DD} or GND		45	mA
		Unloaded outputs, 66 MHz REF (-1, -2)		35	
		Unloaded outputs, 33 MHz REF (-1, -2)		20	

NB2304A

Table 8. SWITCHING CHARACTERISTICS FOR INDUSTRIAL TEMPERATURE DEVICES

(All parameters are specified with loaded outputs)

Parameter	Description	Test Conditions	Min	Typ	Max	Unit
t ₁	Output Frequency	30 pF load (all devices) 15 pF load (-1, -2)	15 15		100 133.3	MHz
t ₁	Duty Cycle = (t ₂ / t ₁) * 100 (all devices)	Measured at 1.4 V, F _{OUT} ≤ 66.66 MHz 30 pF load	40.0	50.0	60.0	%
		Measured at 1.4 V, F _{OUT} ≤ 50 MHz 15 pF load	45.0	50.0	55.0	
t ₃	Output Rise Time (-1, -2)	Measured between 0.8 V and 2.0 V 30 pF load			2.50	ns
		Measured between 0.8 V and 2.0 V 15 pF load			1.50	
	Output Rise Time (-1H)	Measured between 0.8 V and 2.0 V 30 pF load			1.50	
t ₄	Output Fall Time (-1, -2)	Measured between 2.0 V and 0.8 V 30 pF load			2.50	ns
		Measured between 2.0 V and 0.8 V 15 pF load			1.50	
	Output Fall Time (-1H)	Measured between 2.0 V and 0.8 V 30 pF load			1.25	
t ₅	Output-to-Output Skew on same Bank (-1, -2)	All outputs equally loaded			200	ps
	Output-to-Output Skew (-1H)	All outputs equally loaded			200	
	Output Bank A-to-Output Bank B skew (-1)	All outputs equally loaded			200	
	Output Bank A-to-Output Bank B skew (-2)	All outputs equally loaded			400	
t ₆	Delay, REF Rising Edge to FBK Rising Edge	Measured at V _{DD} /2		0	±250	ps
t ₇	Device-to-Device Skew	Measured at V _{DD} /2 on the FBK pins of the device		0	500	ps
t ₈	Output Slew Rate	Measured between 0.8 V and 2.0 V using Test Circuit #2	1			V/ns
t _J	Cycle-to-Cycle Jitter (-1, -1H)	Measured at 66.67 MHz, loaded outputs, 15 pF load			180	ps
		Measured at 66.67 MHz, loaded outputs, 30 pF load			200	
		Measured at 133.3 MHz, loaded outputs, 15 pF load			100	
	Cycle-to-Cycle Jitter (-2)	Measured at 66.67 MHz, loaded outputs, 30 pF load			400	ps
		Measured at 66.67 MHz, loaded outputs, 15 pF load			380	
t _{LOCK}	PLL Lock Time	Stable power supply, valid clock presented on REF and FBK pins			1.0	ms

Zero Delay and Skew Control

For applications requiring zero input-output delay, all outputs must be equally loaded.

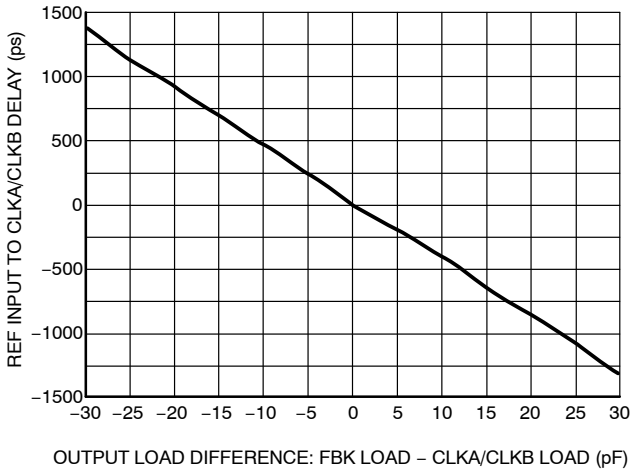

Figure 3. REF Input to CLKA/CLKB Delay vs. Difference in Loading between FBK Pin and CLKA/CLKB Pins

To close the feedback loop of the NB2304A, the FBK pin can be driven from any of the four available output pins. The output driving the FBK pin will be driving a total load of 7 pF plus any additional load that it drives. The relative loading of this output (with respect to the remaining outputs) can adjust the input output delay. This is shown in Figure 3.

For applications requiring zero input-output delay, all outputs including the one providing feedback should be equally loaded. If input-output delay adjustments are required, use Figure 3 to calculate loading differences between the feedback output and remaining outputs. For zero output-output skew, be sure to load outputs equally.

SWITCHING WAVEFORMS

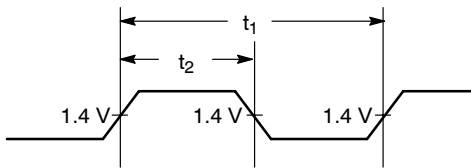

Figure 4. Duty Cycle Timing

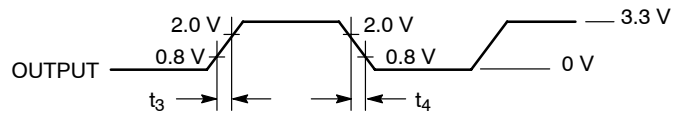

Figure 5. All Outputs Rise/Fall Time

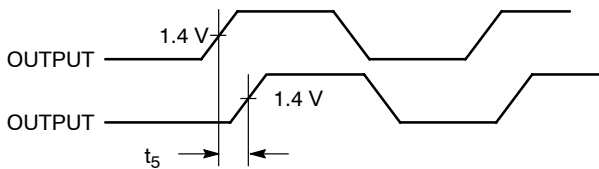

Figure 6. Output - Output Skew

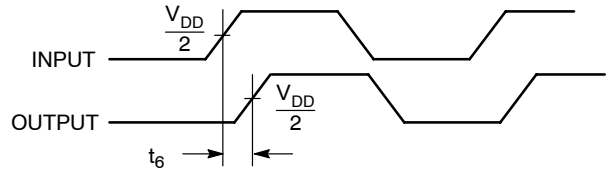

Figure 7. Input - Output Propagation Delay

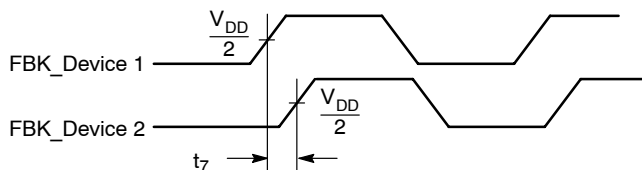

Figure 8. Device - Device Skew

NB2304A

TEST CIRCUITS

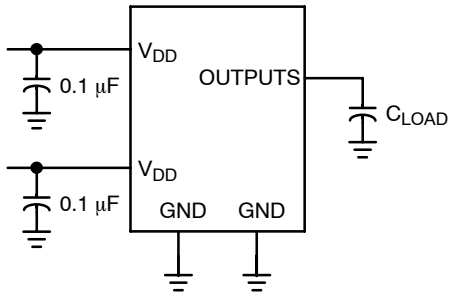

Figure 9. Test Circuit #1

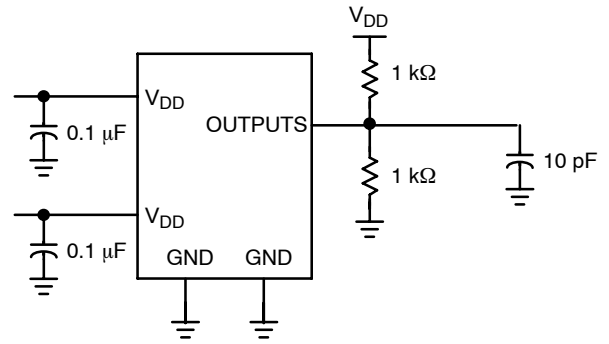

Figure 10. Test Circuit #2
For parameter t_b (output slew rate) on -1H devices

BLOCK DIAGRAMS

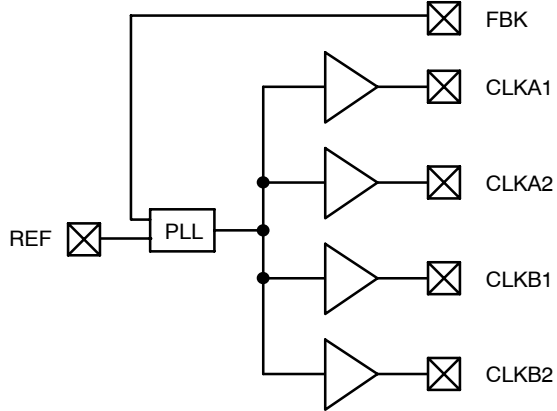

Figure 11. NB2304Ax1 and NB2304Ax1H

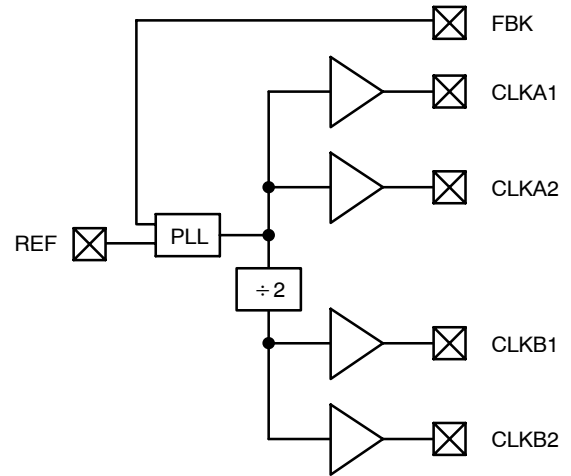

Figure 12. NB2304Ax2

NB2304A

ORDERING INFORMATION

Device	Marking	Operating Range	Package	Shipping†	Availability
NB2304AC1DG	4C1	Commercial	SOIC-8 (Pb-Free)	98 Units / Rail	<i>Now</i>
NB2304AC1DR2G	4C1	Commercial	SOIC-8 (Pb-Free)	2500 Tape & Reel	<i>Now</i>
NB2304AI1DG	4I1	Industrial	SOIC-8 (Pb-Free)	98 Units / Rail	<i>Now</i>
NB2304AI1DR2G	4I1	Industrial	SOIC-8 (Pb-Free)	2500 Tape & Reel	<i>Now</i>
NB2304AC1HDG	4C1H	Commercial	SOIC-8 (Pb-Free)	98 Units / Rail	<i>Now</i>
NB2304AC1HDR2G	4C1H	Commercial	SOIC-8 (Pb-Free)	2500 Tape & Reel	<i>Now</i>
NB2304AI1HDG	4I1H	Industrial	SOIC-8 (Pb-Free)	98 Units / Rail	<i>Now</i>
NB2304AI1HDR2G	4I1H	Industrial	SOIC-8 (Pb-Free)	2500 Tape & Reel	<i>Now</i>
NB2304AC2DG	4C2	Commercial	SOIC-8 (Pb-Free)	98 Units / Rail	<i>Now</i>
NB2304AC2DR2G	4C2	Commercial	SOIC-8 (Pb-Free)	2500 Tape & Reel	<i>Now</i>
NB2304AI2DG	4I2	Industrial	SOIC-8 (Pb-Free)	98 Units / Rail	<i>Now</i>
NB2304AI2DR2G	4I2	Industrial	SOIC-8 (Pb-Free)	2500 Tape & Reel	<i>Now</i>

†For information on tape and reel specifications, including part orientation and tape sizes, please refer to our Tape and Reel Packaging Specifications Brochure, BRD8011/D.

NB2304A

PACKAGE DIMENSIONS

SOIC-8 NB
CASE 751-07
ISSUE AG

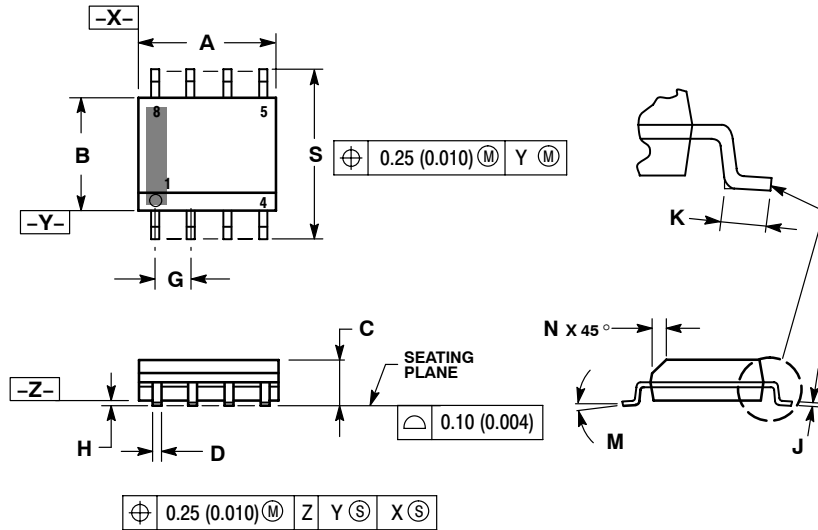

NOTES:

1. DIMENSIONING AND TOLERANCING PER ANSI Y14.5M, 1982.
2. CONTROLLING DIMENSION: MILLIMETER.
3. DIMENSION A AND B DO NOT INCLUDE MOLD PROTRUSION.
4. MAXIMUM MOLD PROTRUSION 0.15 (0.006) PER SIDE.
5. DIMENSION D DOES NOT INCLUDE DAMBAR PROTRUSION. ALLOWABLE DAMBAR PROTRUSION SHALL BE 0.127 (0.005) TOTAL IN EXCESS OF THE D DIMENSION AT MAXIMUM MATERIAL CONDITION.
6. 751-01 THRU 751-06 ARE OBSOLETE. NEW STANDARD IS 751-07.

DIM	MILLIMETERS		INCHES	
	MIN	MAX	MIN	MAX
A	4.80	5.00	0.189	0.197
B	3.80	4.00	0.150	0.157
C	1.35	1.75	0.053	0.069
D	0.33	0.51	0.013	0.020
G	1.27 BSC		0.050 BSC	
H	0.10	0.25	0.004	0.010
J	0.19	0.25	0.007	0.010
K	0.40	1.27	0.016	0.050
M	0°	8°	0°	8°
N	0.25	0.50	0.010	0.020
S	5.80	6.20	0.228	0.244

SOLDERING FOOTPRINT*

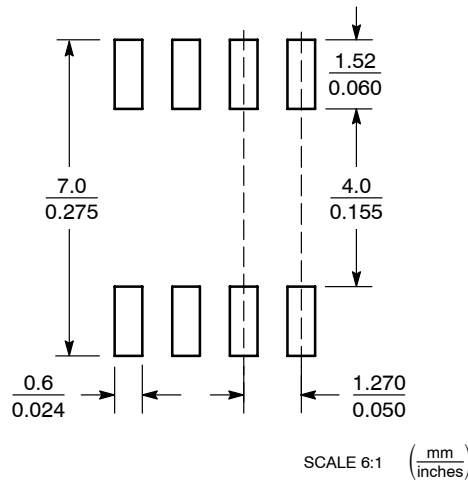

*For additional information on our Pb-Free strategy and soldering details, please download the ON Semiconductor Soldering and Mounting Techniques Reference Manual, SOLDERRM/D.

Licensed under US patent Nos 5,488,627, 6,646,463 and 5,631,920.

ON Semiconductor and are registered trademarks of Semiconductor Components Industries, LLC (SCILLC). SCILLC reserves the right to make changes without further notice to any products herein. SCILLC makes no warranty, representation or guarantee regarding the suitability of its products for any particular purpose, nor does SCILLC assume any liability arising out of the application or use of any product or circuit, and specifically disclaims any and all liability, including without limitation special, consequential or incidental damages. "Typical" parameters which may be provided in SCILLC data sheets and/or specifications can and do vary in different applications and actual performance may vary over time. All operating parameters, including "Typicals" must be validated for each customer application by customer's technical experts. SCILLC does not convey any license under its patent rights nor the rights of others. SCILLC products are not designed, intended, or authorized for use as components in systems intended for surgical implant into the body, or other applications intended to support or sustain life, or for any other application in which the failure of the SCILLC product could create a situation where personal injury or death may occur. Should Buyer purchase or use SCILLC products for any such unintended or unauthorized application, Buyer shall indemnify and hold SCILLC and its officers, employees, subsidiaries, affiliates, and distributors harmless against all claims, costs, damages, and expenses, and reasonable attorney fees arising out of, directly or indirectly, any claim of personal injury or death associated with such unintended or unauthorized use, even if such claim alleges that SCILLC was negligent regarding the design or manufacture of the part. SCILLC is an Equal Opportunity/Affirmative Action Employer. This literature is subject to all applicable copyright laws and is not for resale in any manner.

PUBLICATION ORDERING INFORMATION

LITERATURE FULFILLMENT:
Literature Distribution Center for ON Semiconductor
P.O. Box 5163, Denver, Colorado 80217 USA
Phone: 303-675-2175 or 800-344-3860 Toll Free USA/Canada
Fax: 303-675-2176 or 800-344-3867 Toll Free USA/Canada
Email: orderlit@onsemi.com

N. American Technical Support: 800-282-9855 Toll Free USA/Canada
Europe, Middle East and Africa Technical Support:
Phone: 421 33 790 2910
Japan Customer Focus Center
Phone: 81-3-5773-3850

ON Semiconductor Website: www.onsemi.com
Order Literature: <http://www.onsemi.com/orderlit>

For additional information, please contact your local Sales Representative

Компания «Life Electronics» занимается поставками электронных компонентов импортного и отечественного производства от производителей и со складов крупных дистрибьюторов Европы, Америки и Азии.

С конца 2013 года компания активно расширяет линейку поставок компонентов по направлению коаксиальный кабель, кварцевые генераторы и конденсаторы (керамические, пленочные, электролитические), за счёт заключения дистрибьюторских договоров

Мы предлагаем:

- Конкурентоспособные цены и скидки постоянным клиентам.
- Специальные условия для постоянных клиентов.
- Подбор аналогов.
- Поставку компонентов в любых объемах, удовлетворяющих вашим потребностям.
- Приемлемые сроки поставки, возможна ускоренная поставка.
- Доставку товара в любую точку России и стран СНГ.
- Комплексную поставку.
- Работу по проектам и поставку образцов.
- Формирование склада под заказчика.
- Сертификаты соответствия на поставляемую продукцию (по желанию клиента).
- Тестирование поставляемой продукции.
- Поставку компонентов, требующих военную и космическую приемку.
- Входной контроль качества.
- Наличие сертификата ISO.

В составе нашей компании организован Конструкторский отдел, призванный помогать разработчикам, и инженерам.

Конструкторский отдел помогает осуществить:

- Регистрацию проекта у производителя компонентов.
- Техническую поддержку проекта.
- Защиту от снятия компонента с производства.
- Оценку стоимости проекта по компонентам.
- Изготовление тестовой платы монтаж и пусконаладочные работы.



Тел: +7 (812) 336 43 04 (многоканальный)

Email: org@lifeelectronics.ru