

## General Description

The AP1681 is a powerful high performance AC/DC power supply controller for dimmable LED lighting applications. The device uses Pulse Frequency Modulation (PFM) technology to regulate output current according to the wall dimmer conduct angle. The AP1681 achieves wide dimming range without visible flicker and is compatible with diverse dimmers.

The AP1681 features low start-up current, low operation current and high efficiency. It also has rich protection functions including over voltage, short circuit, over current and over temperature protections.

The AP1681 is available in SOIC-8 package.

## Features

- Primary Side Control for Output Current Regulation Without Opto-coupler and Secondary CV/CC Control Circuitry
- Adjustable Full Brightness and Full Dimming Setting
- Wide Dimming Range From 100% to 1%, Down to Full Darkness
- Adjustable Dimming Curve for Human Eye Sensitivity
- No Visible Flicker
- Connectivity with Analog / Digital / Hybrid Dimming Mode
- Built-in Acceleration Start
- Adjustable Soft-start Timing
- CV Open-load Regulation and Reload Detection
- Over Voltage and Short Circuit Protection
- Over Temperature Protection
- Over Current Protection
- Maximum Switch On-time Protection

## Applications

- Dimmable LED Driver Suit for Leading-edge Dimmer, Trailing-edge Dimmer, R Type, R-C Type or R-L Type Dimmer



Figure 1. Package Type of AP1681

## Pin Configuration

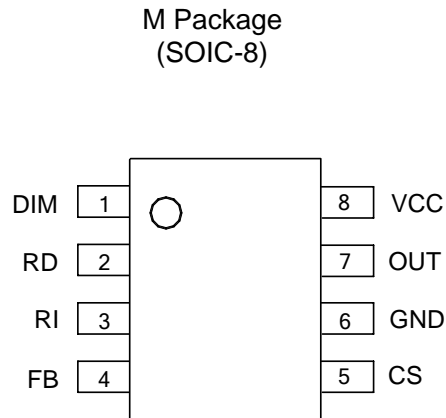


Figure 2. Pin Configuration of AP1681 (Top View)

## Pin Description

Pin Number	Pin Name	Function
1	DIM	Dimming control signal input
2	RD	Full brightness level setting
3	RI	Full dimming level setting
4	FB	The feedback voltage sensing from the auxiliary winding
5	CS	Primary current sensing
6	GND	Ground. Current return for gate driver and control circuits of the IC
7	OUT	Gate driver output
8	VCC	Supply voltage of gate driver and control circuits of the IC

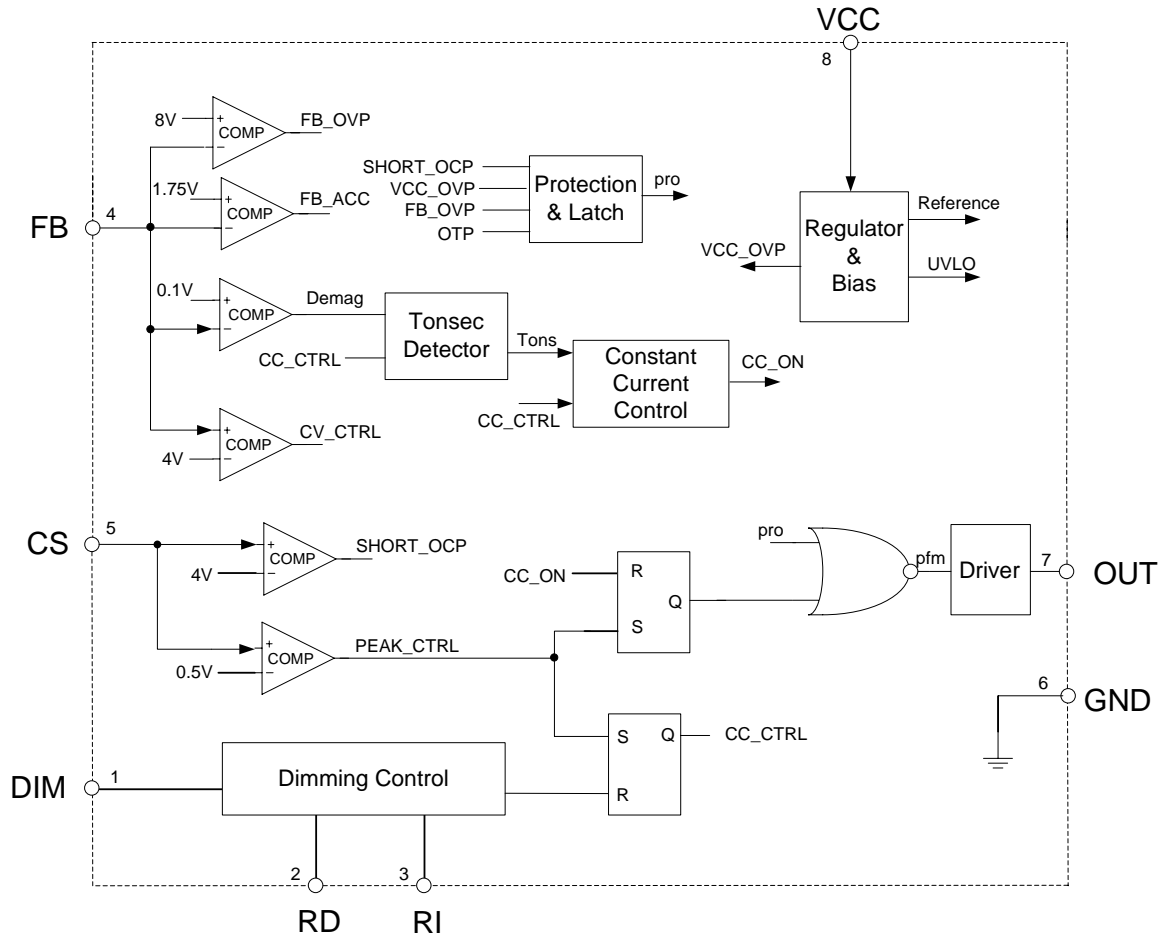
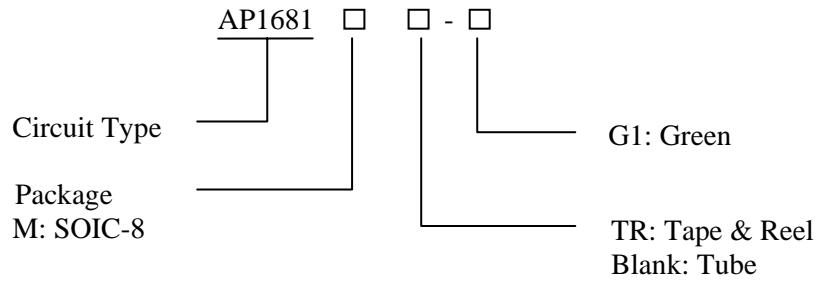
**Functional Block Diagram**


Figure 3. Functional Block Diagram of AP1681



**Off-line Primary Side Regulation Controller for Dimmable LED Driver      AP1681**

**Ordering Information**



Package	Temperature Range	Part Number	Marking ID	Packing Type
SOIC-8	-40 to 105°C	AP1681M-G1	1681M-G1	Tube
		AP1681MTR-G1	1681M-G1	Tape & Reel

BCD Semiconductor's Pb-free products, as designated with "G1" suffix in the part number, are RoHS compliant and green.

**Absolute Maximum Ratings (Note 1)**

Parameter	Symbol	Value	Unit
Power Supply Voltage	$V_{CC}$	-0.3 to 30	V
Driver Output Current	$I_{OUT}$	$\pm 300$	mA
Voltage at RD, RI, DIM, CS	$V_{RD}, V_{RI},$ $V_{DIM}, V_{CS}$	-0.3 to 7	V
FB Input Voltage	$V_{FB}$	-40 to 10	V
Operating Junction Temperature	$T_J$	150	°C
Storage Temperature	$T_{STG}$	-65 to 150	°C
Lead Temperature (Soldering, 10 sec)	$T_{LEAD}$	300	°C
Power Dissipation at $T_A=50^\circ\text{C}$	$P_D$	0.65	W
Thermal Resistance (Junction-to-Ambient)	$\theta_{JA}$	150	°C/W
ESD (Machine Model)		200	V
ESD (Human Body Model)		4000	V

Note 1: Stresses greater than those listed under “Absolute Maximum Ratings” may cause permanent damage to the device. These are stress ratings only, and functional operation of the device at these or any other conditions beyond those indicated under “Recommended Operating Conditions” is not implied. Exposure to “Absolute Maximum Ratings” for extended periods may affect device reliability.

**Recommended Operating Conditions**

Parameter	Symbol	Min	Max	Unit
Power Supply Voltage	$V_{CC}$	10.8	21.5	V
Ambient Temperature	$T_A$	-40	105	°C



**Off-line Primary Side Regulation Controller for Dimmable LED Driver AP1681**

**Electrical Characteristics**

V<sub>CC</sub>=15V, T<sub>A</sub>=25°C, unless otherwise specified.

Parameter	Symbol	Conditions	Min	Typ	Max	Unit
<b>UVLO Section</b>						
Start-up Threshold	V <sub>TH</sub> (ST)		16.5	19	21.5	V
Minimal Operating Voltage	V <sub>OPR</sub> (Min)	After turn on	7.2	9	10.8	
<b>Standby Current Section</b>						
Start-up Current	I <sub>ST</sub>	V <sub>CC</sub> =V <sub>TH</sub> (ST)-0.5V, Before start up		1.7	10	μA
Operating Current	I <sub>CC</sub>	Static	700	900	1100	
<b>Drive Output Section</b>						
Output High Level Voltage	V <sub>OH</sub>	I <sub>GD-SOURCE</sub> =20mA V <sub>CC</sub> =12V	8			V
Output Low Level Voltage	V <sub>OL</sub>	I <sub>GD-SINK</sub> =20mA V <sub>CC</sub> =12V			1	V
Output Voltage Rise Time	t <sub>R</sub>	C <sub>L</sub> =1nF	120	220	320	ns
Output Voltage Fall Time	t <sub>F</sub>	C <sub>L</sub> =1nF	30	50	90	ns
Output Clamp Voltage	V <sub>O-CLAMP</sub>	I <sub>GD-SOURCE</sub> =5mA V <sub>CC</sub> =20V	11	13	15	V
UVLO Saturation Voltage	V <sub>UVLO</sub>	V <sub>CC</sub> =0 to V <sub>CC-ON</sub> I <sub>SINK</sub> =10mA			1	V
Maximum Switch On-time	t <sub>ONP_MAX</sub>			16.5		μs
<b>DIM Input Section</b>						
Voltage Gain to RI		ΔV <sub>RI</sub> /ΔV <sub>DIM</sub>	-1.2	-1.1	-1.0	
Internal Source Current			11	20	35	μA
Reload Threshold			0.8	1	1.25	V
<b>RD and RI Section</b>						
RD Pin Voltage	V <sub>RD</sub>		1.3	1.5	1.75	V
Maximum RD Current				150		μA
Maximum RI Current				250		μA
<b>Current Sense Section</b>						
Current Sense Voltage	V <sub>CS</sub>		450	500	560	mV
Maximum CS Current		V <sub>DIM</sub> =0		120		μA
Leading Edge Blanking				600		ns

**Off-line Primary Side Regulation Controller for Dimmable LED Driver AP1681****Electrical Characteristics (Continued)**

$V_{CC}=15V$ ,  $T_A=25^{\circ}C$ , unless otherwise specified.

Parameter	Symbol	Conditions	Min	Typ	Max	Unit
<b>Feedback Input Section</b>						
CV Feedback Threshold	$V_{FB-CV}$		3.0	4.0	5.0	V
FB Pin Input Leakage Current	$I_{FB}$	$V_{FB}=4V$	1.0	2	3.0	$\mu A$
Acceleration Start Threshold			1.35	1.75	2.15	V
Over Voltage Protection	$V_{FB-OVP}$		6.5	8	9.5	V
<b>Over Temperature Protection Section</b>						
Shutdown Temperature				140		$^{\circ}C$
Temperature Hysteresis				20		$^{\circ}C$

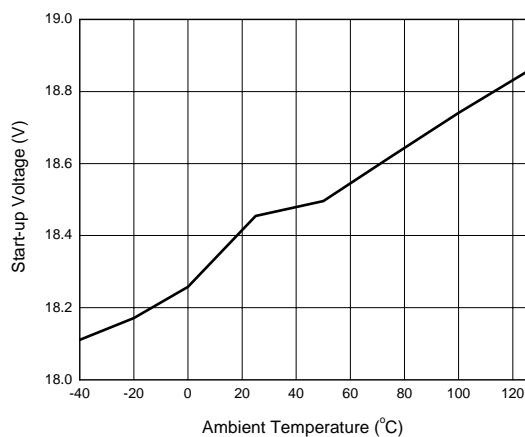
**Typical Performance Characteristics**

Figure 4. Start-up Voltage vs. Ambient Temperature

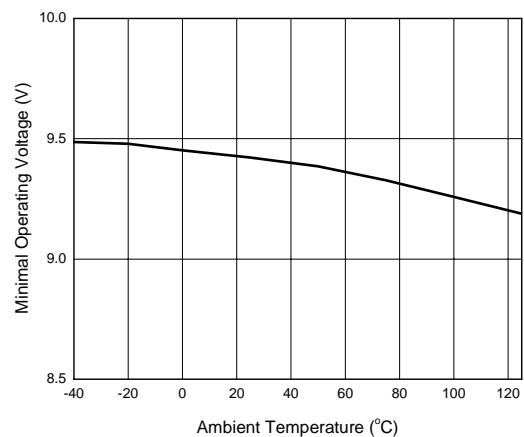


Figure 5. Minimal Operating Voltage vs. Ambient Temperature



### Typical Performance Characteristics (Continued)

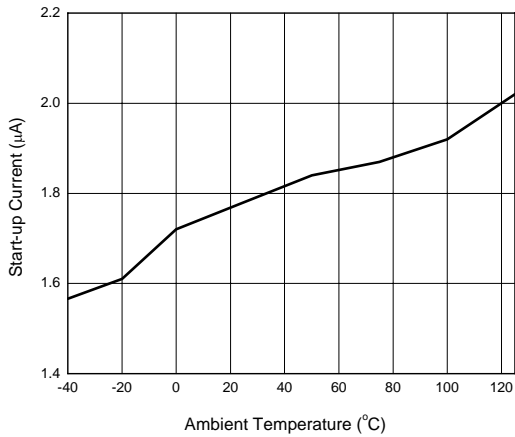


Figure 6. Start-up Current vs. Ambient Temperature

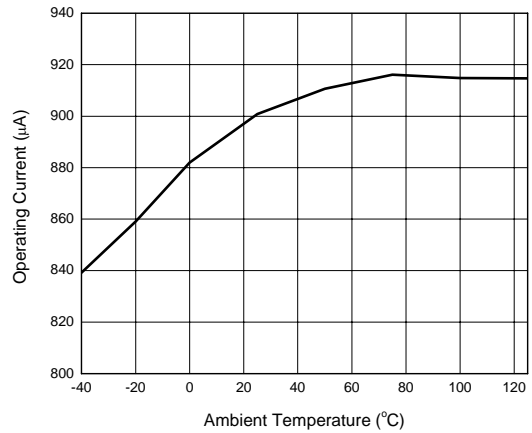


Figure 7. Operating Current vs. Ambient Temperature

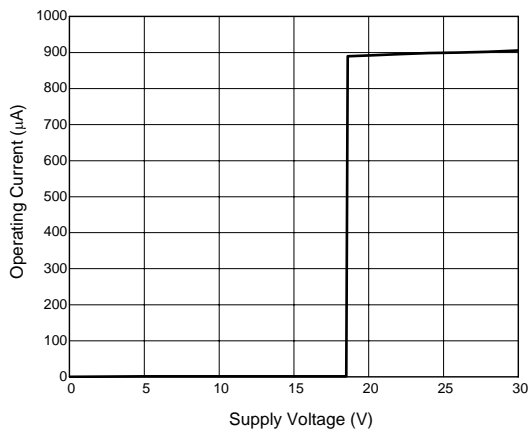


Figure 8. Operating Current vs. Supply Voltage

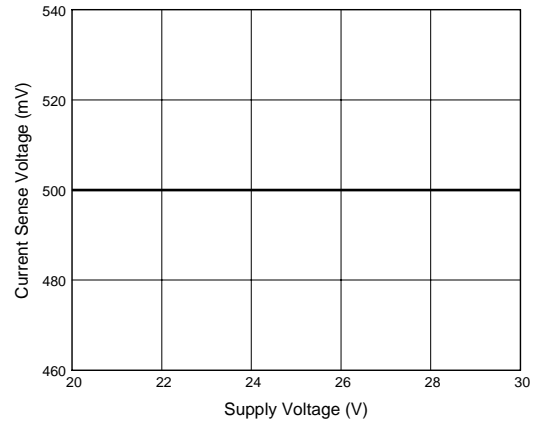


Figure 9. Current Sense Voltage vs. Supply Voltage



Typical Performance Characteristics (Continued)

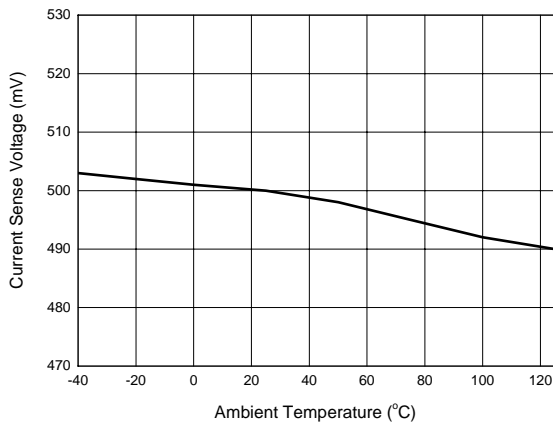


Figure 10. Current Sense Voltage vs. Ambient Temperature

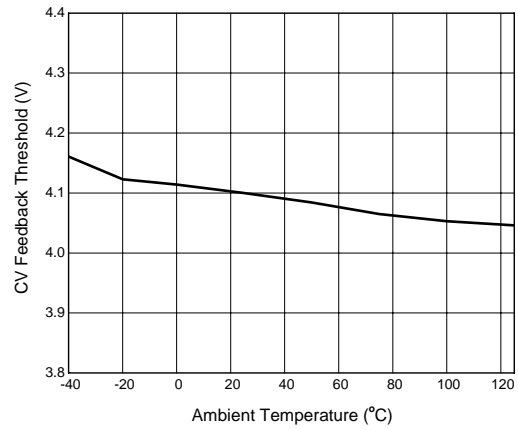


Figure 11. CV Feedback Threshold vs. Ambient Temperature

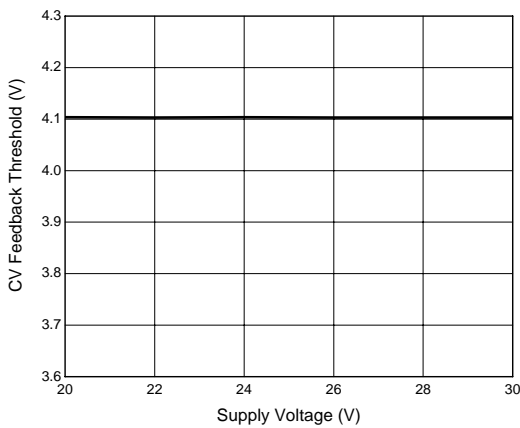


Figure 12. CV Feedback Threshold vs. Supply Voltage

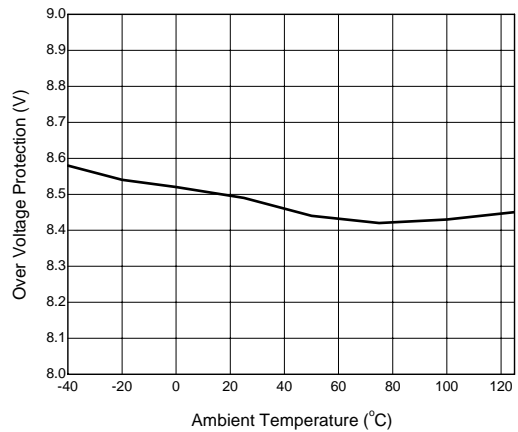


Figure 13. Over Voltage Protection vs. Ambient Temperature

**Typical Performance Characteristics (Continued)**

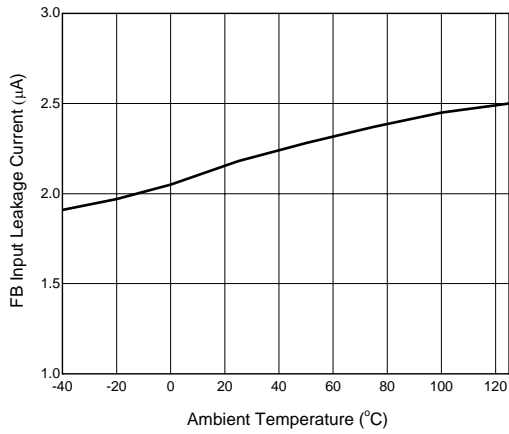


Figure 14. FB Input Leakage Current vs. Ambient Temperature

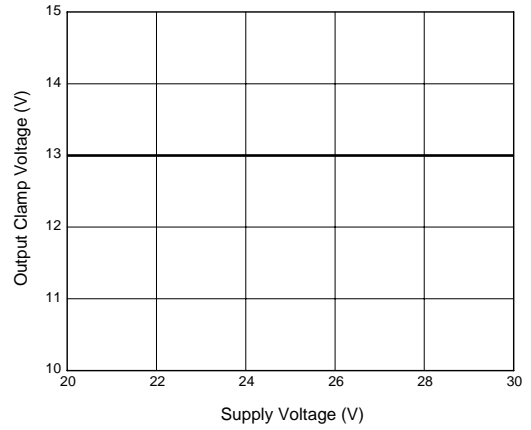


Figure 15. Output Clamp Voltage vs. Supply Voltage

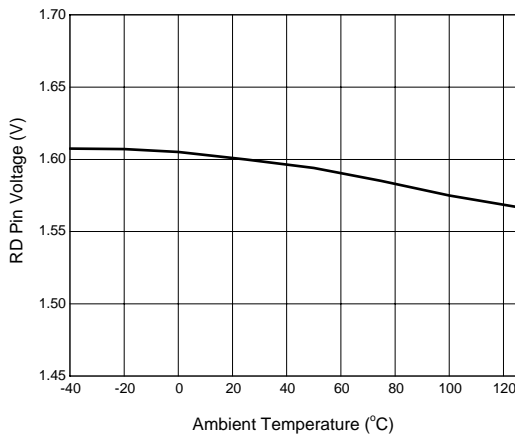


Figure 16. RD Pin Voltage vs. Ambient Temperature

**Off-line Primary Side Regulation Controller for Dimmable LED Driver AP1681**

**Typical Application**

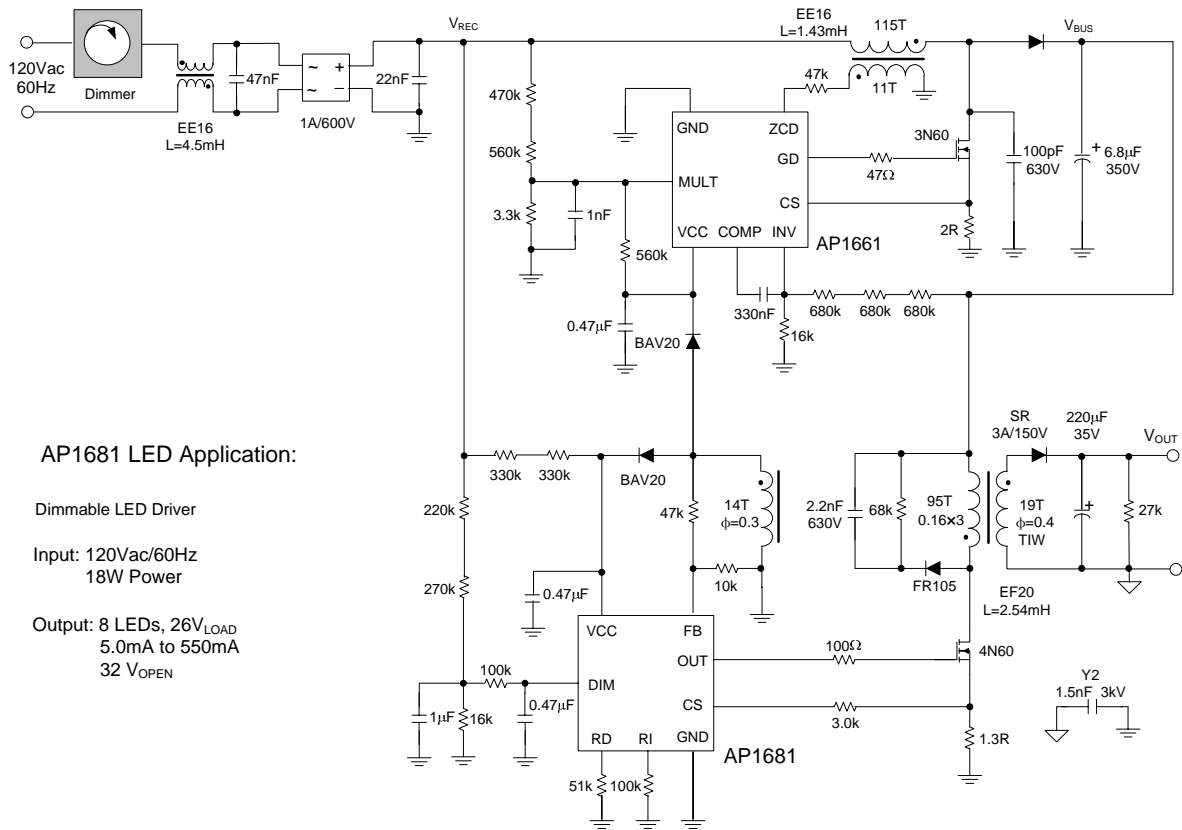
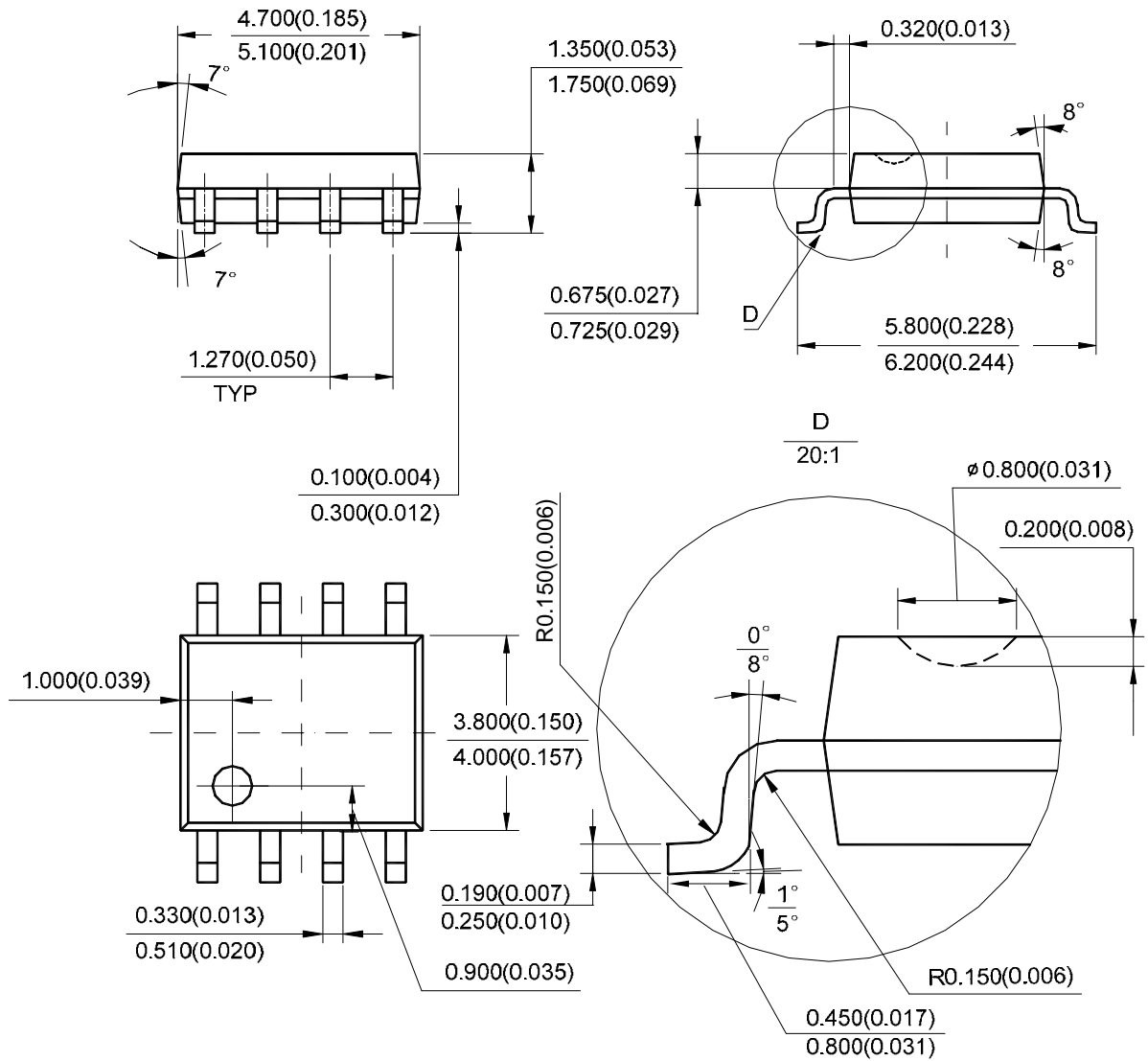


Figure 17. Typical Application of AP1681

**Mechanical Dimensions**

**SOIC-8**

**Unit: mm(inch)**



Note: Eject hole, oriented hole and mold mark is optional.



## **BCD Semiconductor Manufacturing Limited**

<http://www.bcdsemi.com>

### **IMPORTANT NOTICE**

BCD Semiconductor Manufacturing Limited reserves the right to make changes without further notice to any products or specifications herein. BCD Semiconductor Manufacturing Limited does not assume any responsibility for use of any its products for any particular purpose, nor does BCD Semiconductor Manufacturing Limited assume any liability arising out of the application or use of any its products or circuits. BCD Semiconductor Manufacturing Limited does not convey any license under its patent rights or other rights nor the rights of others.

---

#### **MAIN SITE**

##### **- Headquarters**

##### **BCD Semiconductor Manufacturing Limited**

No. 1600, Zi Xing Road, Shanghai Zizhu Science-based Industrial Park, 200241, China  
Tel: +86-21-24162266, Fax: +86-21-24162277

##### **- Wafer Fab**

##### **Shanghai SIM-BCD Semiconductor Manufacturing Co., Ltd.**

800 Yi Shan Road, Shanghai 200233, China  
Tel: +86-21-6485 1491, Fax: +86-21-5450 0008

#### **REGIONAL SALES OFFICE**

##### **Shenzhen Office**

##### **Shanghai SIM-BCD Semiconductor Manufacturing Co., Ltd., Shenzhen Office**

Unit A Room 1203, Skyworth Bldg., Gaoxin Ave. 1.S., Nanshan District, Shenzhen, China  
Tel: +86-755-8826 7951  
Fax: +86-755-8826 7865

##### **Taiwan Office**

##### **BCD Semiconductor (Taiwan) Company Limited**

4F, 298-1, Rui Guang Road, Nei-Hu District, Taipei, Taiwan  
Tel: +886-2-2656 2808  
Fax: +886-2-2656 2806

##### **USA Office**

##### **BCD Semiconductor Corp.**

30920 Huntwood Ave. Hayward, CA 94544, USA  
Tel : +1-510-324-2988  
Fax: +1-510-324-2788

Компания «Life Electronics» занимается поставками электронных компонентов импортного и отечественного производства от производителей и со складов крупных дистрибьюторов Европы, Америки и Азии.

С конца 2013 года компания активно расширяет линейку поставок компонентов по направлению коаксиальный кабель, кварцевые генераторы и конденсаторы (керамические, пленочные, электролитические), за счёт заключения дистрибьюторских договоров

Мы предлагаем:

- Конкурентоспособные цены и скидки постоянным клиентам.
- Специальные условия для постоянных клиентов.
- Подбор аналогов.
- Поставку компонентов в любых объемах, удовлетворяющих вашим потребностям.
- Приемлемые сроки поставки, возможна ускоренная поставка.
- Доставку товара в любую точку России и стран СНГ.
- Комплексную поставку.
- Работу по проектам и поставку образцов.
- Формирование склада под заказчика.
- Сертификаты соответствия на поставляемую продукцию (по желанию клиента).
- Тестирование поставляемой продукции.
- Поставку компонентов, требующих военную и космическую приемку.
- Входной контроль качества.
- Наличие сертификата ISO.

В составе нашей компании организован Конструкторский отдел, призванный помогать разработчикам, и инженерам.

Конструкторский отдел помогает осуществить:

- Регистрацию проекта у производителя компонентов.
- Техническую поддержку проекта.
- Защиту от снятия компонента с производства.
- Оценку стоимости проекта по компонентам.
- Изготовление тестовой платы монтаж и пусконаладочные работы.



Тел: +7 (812) 336 43 04 (многоканальный)

Email: [org@lifeelectronics.ru](mailto:org@lifeelectronics.ru)