

# TMCP SOCKET M

**Modular base, 2-position, for holding two circuit breakers, each with single positions**

## CLIPLINE

Data Sheet  
104391\_en\_00

© PHOENIX CONTACT 2010-05-26

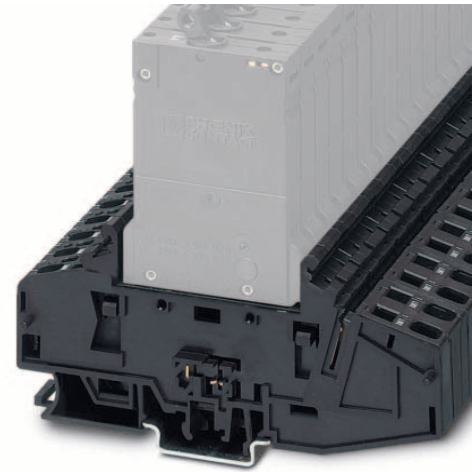

## 1 Description

The TMCP SOCKET M base is snapped onto a DIN rail and can accommodate two single-position circuit breakers of type ECP..., ECP-E.... or TMCP....

The two-channel bases are modular, which means that larger distribution systems can be created. A TMCP CONNECT LR base termination element is inserted at both the start and end of the system.

The base module has an integrated bridge shaft on the power input side. A plug-in bridge system, which can be cut to any length, can thus be used to create a current distribution with up to 40-positions. The maximum supply current depends on the type of supply and the bridge used.

Signal contacts, N/C contacts, and N/O contacts are already integrated in the circuit breakers.

All electrical connections are established using spring-cage terminal blocks.

Individual indication can be established via connection 11 on the TMCP CONNECT LR base termination elements and connection 12 on the base module.

Group indication is fully wired internally. The supply at connection 13 and the signal tap at connection 14 support the quick creation of a signal loop via all circuit breakers.



**NOTE:** If a slot is free on a base, the ECP...-SB signal bridge must be used here to feed through the signal.



Make sure you always use the latest documentation. It can be downloaded at [www.phoenixcontact.net/catalog](http://www.phoenixcontact.net/catalog).



This data sheet is valid for the products listed on the following page:

## 2 Ordering data

### Base

Description	Type	Order No.	Pcs./Pkt.
<b>Modular base</b> , 2-pos., designed to accommodate two 1-pos. circuit breakers, width of 12.5 mm per position	TMCP SOCKET M	0916589	10

### Accessories

Description	Type	Order No.	Pcs./Pkt.
<b>Base termination elements</b> , can be plugged into both the left and right-hand side, contain the connections for the reset inputs/group query	TMCP CONNECT LR	0916592	3
<b>Spring lock</b> , for mechanical locking in the case of overhead mounting, 1-pos.	ECP-LOCK	0912021	10
<b>Spring lock</b> , for mechanical locking in the case of overhead mounting, 1-pos.	SPRING-LOCK	0713009	10
<b>Zack marker strip</b> , 10-section, for labeling the center of the terminal block	ZB 6	See CLIPLINE catalog	
<b>UniCard sheets</b> , for labeling terminal blocks using a Zack marker strip groove, 80-section, can be labeled with BLUEMARK and CMS-P1-PLOTTER, color: white	UC-TM 6	0818085	10
<b>Fixed bridge</b> , plug-in, not insulated, 500 mm long, can be cut to length, for distribution of the supply potential in the base, $I_{max} = 50$ A	FBST 500 TMCP	0916615	20
<b>Continuous plug-in bridge</b> , 500 m long, can be cut to length, for potential distribution, $I_{max} = 32$ A, red	FBST 500-PLC RD	2966786	20
<b>Continuous plug-in bridge</b> , 500 m long, can be cut to length, for potential distribution, $I_{max} = 32$ A, blue	FBST 500-PLC BU	2966692	20
<b>Signal bridge</b> , plug-in, for bridging group indication when there is a free slot on the TMCP SOCKET M base, $I_{max} = 1$ A	TCMP SB	0916602	6

### 3 Technical data

General data	
TMCP CONNECT LR (width x length)	25 mm (2-pos.) x 115 mm
TMCP SOCKET M (width x length)	6 mm x 115 mm
Height on NS 35/7.5... DIN rail	110.5 mm
Height on NS 35/15... DIN rail	118 mm
Insulation material	PA-F
Inflammability class according to UL 94	V0
Rated surge voltage	2.5 kV
Pollution degree	2

TMCP SOCKET M		
Test contact for testing group indication on a cable interrupt	$\varnothing = 2$ mm	
Nominal voltage (without circuit breaker)	433 V AC (65 V DC)	
Nominal current (without circuit breaker)	*(When several circuit breakers are mounted in rows, the entire nominal current cannot be led due to the mutual thermal effect. When $I_N \leq 16$ A, the maximum load is 80%. When $I_N > 16$ A, the maximum load is 65%.	
Input (1)		50 A
Output (2)		25 A*
Supply (11)		10 A
Single output (12), group indication (13, 14)		1 A
Internal resistance (without circuit breaker)		
Input/output (1, 2)	$\leq 5$ m $\Omega$	
Signaling,		
parallel (11-12)	$\leq 9$ m $\Omega$ /per position	
serial (13-14)	$\leq 8$ m $\Omega$ /per position	
Supply rail for current distribution, plug-in bridge		
FBST 500-PLC...	$I_{max} = 32$ A	
FBST 500-TMCP (uninsulated power rail $I_{max} = 50$ A (the uninsulated power rail is inserted fully and is therefore safe to touch)	$I_{max} = 50$ A	
Dielectric strength		
Between main circuits (without plug-in bridge)	1500 V	
Main circuit to signal circuit	1500 V	
Signal circuit to signal circuit	1500 V	
Weight		
Central part	85 g, approximately	
Connection elements (pair)	30 g, approximately	

#### Connections

Spring-cage terminal blocks for solid wires and stranded cables with and without ferrules. Use the specified screwdriver size (SD) to release the spring cage.

Connection	Spring-cage terminal blocks for	Stripping length	Screwdriver size (SD)
Input (1)	1.5 mm <sup>2</sup> ... 10 mm <sup>2</sup>	15 mm	SD 2 (0.8 x 4.0 mm)
Output (2)	0.25 mm <sup>2</sup> ... 4 mm <sup>2</sup>	12 mm	SD 1 (0.6 x 3.5 mm)
Auxiliary contacts (11, 13/14)	0.25 mm <sup>2</sup> ... 2.5 mm <sup>2</sup>	10 mm	SD 1 (0.6 x 3.5 mm)
Single output (12)	0.25 mm <sup>2</sup> ... 1.5 mm <sup>2</sup>	10 mm	SD 0 (0.4 x 2.5 mm)

Connection capacity ECP... CONNECT LR	Supply	Group output
	Auxiliary contact 11	Auxiliary contacts 13/14
Nominal voltage	250 V AC (65 V DC)	250 V AC (65 V DC)
Nominal current	10 A	1 A
Maximum load current	10 A for 2.5 mm <sup>2</sup>	1 A for 2.5 mm <sup>2</sup>

## 4 Dimensions

### 4.1 TMCP dimensions with base and base termination element

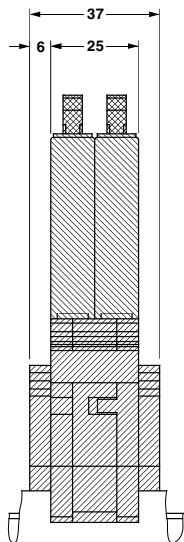
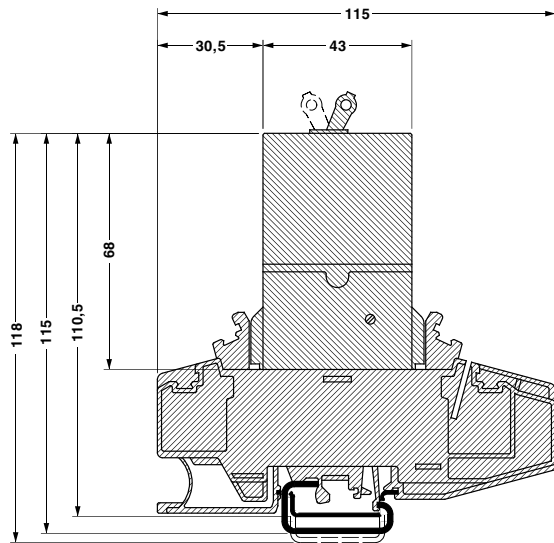

Figure 1 TMCP dimensions... (in mm)

### 4.2 ECP dimensions with base

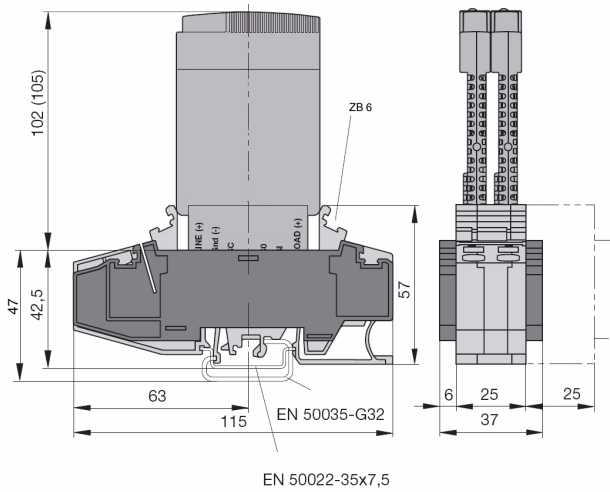

Figure 2 ECP dimensions... (in mm)

## 5 Internal wiring

The internal wiring is illustrated in the circuit diagram.

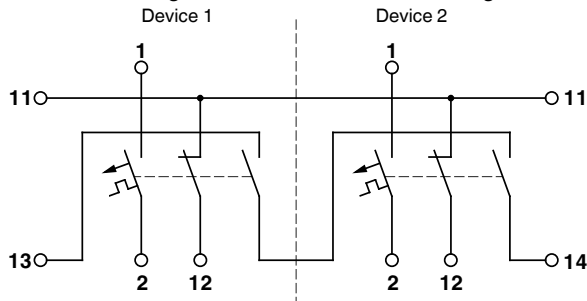
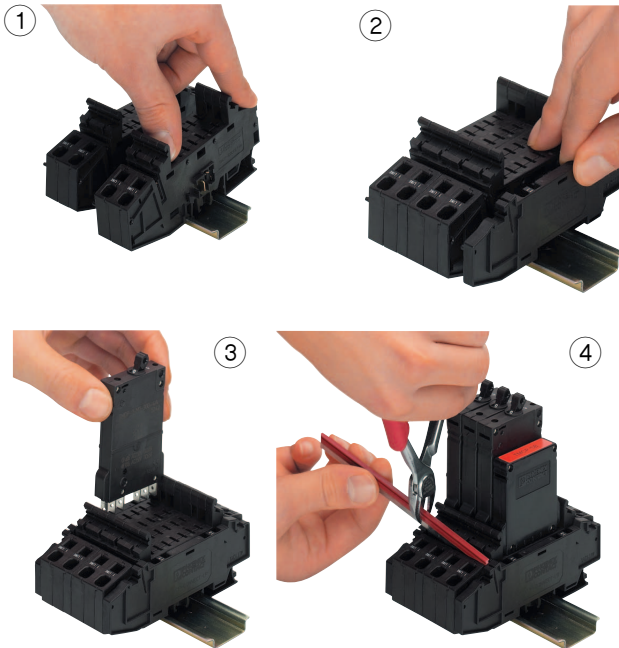

Illustration and definitions when switched off and with zero current.

## 6 Installation



To assemble, proceed as follows:

- Snap the TMCP SOCKET M base onto a DIN rail according to EN 60751 ①. Individual bases can be mounted side by side to create any number of positions.
- Push bases together.
- Snap on TMCP CONNECT LR base termination elements to the left and right-hand side ②. The termination elements contain the contacts for group indication and the supply for individual indication.

- Insert ECP... or TMCP... ③.



**WARNING:** Always fill empty slots with the TMCP SB signal bridge.

- If a slot on the base is empty, the TMCP SB signal bridge is used. It bridges the group signal and replaces the circuit breaker. The bridging option in the base enables supply potential distribution over a maximum of 40 positions.
- Cut FBST 500... plug-in bridge to length as required and insert in bases ④.
- Insert the connecting cables into the spring-cage terminal blocks.
- If required, secure the TMCP... and base using the SPRING-LOCK clamp.
- If required, secure the ECP... and base using the ECP-LOCK clamp.

### 6.1 Locking the base and ECP...

If mounted overhead, the ECP... must be connected to the base using the ECP-LOCK clamp.

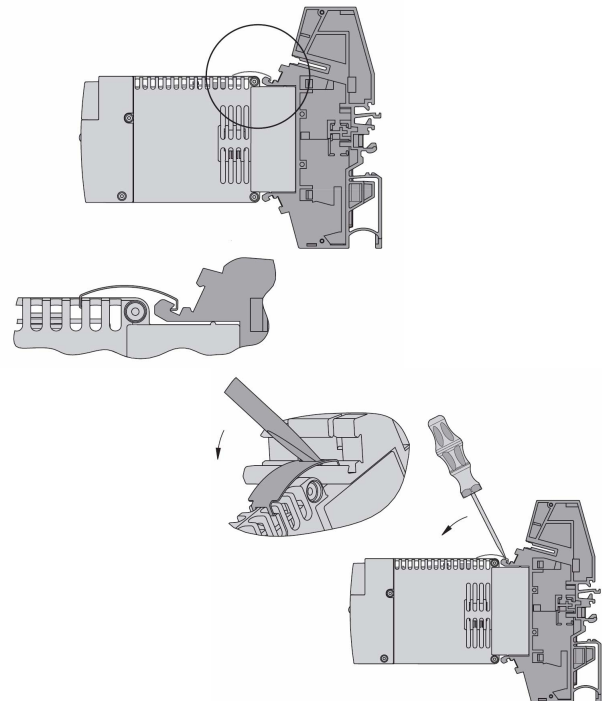

Figure 3 Installing and removing ECP-LOCK

Компания «Life Electronics» занимается поставками электронных компонентов импортного и отечественного производства от производителей и со складов крупных дистрибьюторов Европы, Америки и Азии.

С конца 2013 года компания активно расширяет линейку поставок компонентов по направлению коаксиальный кабель, кварцевые генераторы и конденсаторы (керамические, пленочные, электролитические), за счёт заключения дистрибьюторских договоров

Мы предлагаем:

- Конкурентоспособные цены и скидки постоянным клиентам.
- Специальные условия для постоянных клиентов.
- Подбор аналогов.
- Поставку компонентов в любых объемах, удовлетворяющих вашим потребностям.
- Приемлемые сроки поставки, возможна ускоренная поставка.
- Доставку товара в любую точку России и стран СНГ.
- Комплексную поставку.
- Работу по проектам и поставку образцов.
- Формирование склада под заказчика.
- Сертификаты соответствия на поставляемую продукцию (по желанию клиента).
- Тестирование поставляемой продукции.
- Поставку компонентов, требующих военную и космическую приемку.
- Входной контроль качества.
- Наличие сертификата ISO.

В составе нашей компании организован Конструкторский отдел, призванный помогать разработчикам, и инженерам.

Конструкторский отдел помогает осуществить:

- Регистрацию проекта у производителя компонентов.
- Техническую поддержку проекта.
- Защиту от снятия компонента с производства.
- Оценку стоимости проекта по компонентам.
- Изготовление тестовой платы монтаж и пусконаладочные работы.



Тел: +7 (812) 336 43 04 (многоканальный)

Email: [org@lifeelectronics.ru](mailto:org@lifeelectronics.ru)