



**QUAD FORWARD-CONDUCTING P-GATE THYRISTORS  
PROGRAMMABLE OVERVOLTAGE PROTECTORS**

**TISP6NTP2C High Voltage Ringing SLIC Protector**

**Independent Tracking Overvoltage Protection for Two SLICs:**

- Dual Voltage-Programmable Protectors
- Supports Battery Voltages Down to -155 V
- Low 5 mA max. Gate Triggering Current
- High 150 mA min. (70 °C) Holding Current
- Specified 2/10 Limiting Voltage
- Small Outline Surface Mount Package
- Full 0 °C to 70 °C Temperature Range

**Rated for Common Impulse Waveforms**

Voltage Impulse Wave Shape	Current Impulse Wave Shape	I <sub>PPSM</sub> A
10/1000	10/1000	25
10/700	5/310	40
2/10	2/10	90

**Typical TISP6NTP2C Router Application**

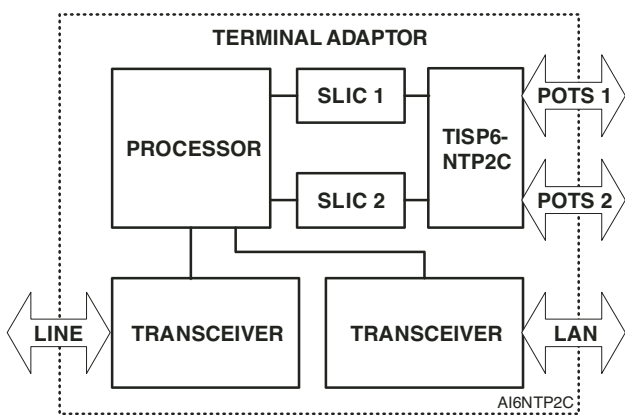

**D Package (Top View)**

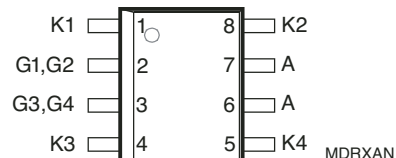

**Device Symbol**

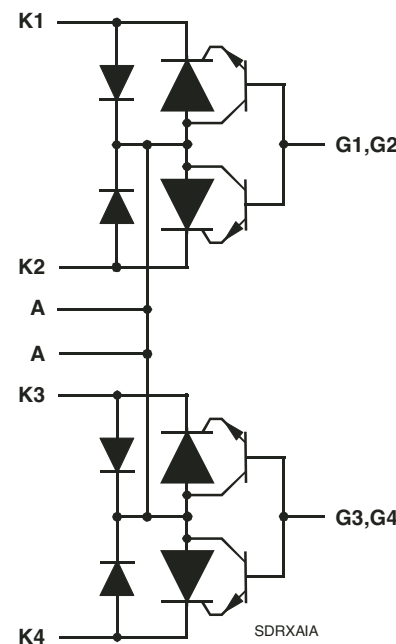

**UL Recognized Components**

**Description**

- The TISP6NTP2C has been designed for short loop systems such as:
- WILL (Wireless In the Local Loop)
  - FITL (Fibre In The Loop)
  - DAML (Digital Added Main Line, Pair Gain)
  - SOHO (Small Office Home Office)
  - ISDN-TA (Integrated Services Digital Network - Terminal Adaptors)

**How to Order**

Device	Package	Carrier	Order As
TISP6NTP2C	D (8-pin Small-Outline)	R (Embossed Tape Reeled)	TISP6NTP2CDR-S

\*RoHS Directive 2002/95/EC Jan 27 2003 including Annex MARCH 2002 – REVISED JULY 2008  
Specifications are subject to change without notice.  
Customers should verify actual device performance in their specific applications.

# TISP6NTP2C High Voltage Ringing SLIC Protector

**BOURNS®**

## Description (Continued)

The systems described often have the need to source two POTS (Plain Old Telephone Service) lines, one for a telephone and the other for a facsimile machine. In a single surface mount package, the TISP6NTP2C protects the two POTS line SLICs (Subscriber Line Interface Circuits) against overvoltages caused by lightning, a.c. power contact and induction.

The TISP6NTP2C has an array of four buffered P-gate forward conducting thyristors with twin commoned gates and a common anode connection. Each thyristor cathode has a separate terminal connection. An antiparallel anode-cathode diode is connected across each thyristor. The buffer transistors reduce the gate supply current.

In use, the cathodes of an TISP6NTP2C thyristors are connected to the four conductors of two POTS lines (see applications information). Each gate is connected to the appropriate negative voltage battery feed of the SLIC driving that line pair. By having separate gates, each SLIC can be protected at a voltage level related to the negative supply voltage of that individual SLIC. The anode of the TISP6NTP2C is connected to the SLIC common. The TISP6NTP2C voltage and current ratings also make it suitable for the protection of ISDN d.c. feeds of down to -115 V (ETSI Technical Report ETR 080:1993, ranges 1 to 5).

Positive overvoltages are clipped to common by forward conduction of the TISP6NTP2C antiparallel diode. Negative overvoltages are initially clipped close to the SLIC negative supply by emitter follower action of the TISP6NTP2C buffer transistor. If sufficient clipping current flows, the TISP6NTP2C thyristor will regenerate and switch into a low voltage on-state condition. As the overvoltage subsides, the high holding current of the TISP6NTP2C helps prevent d.c. latchup.

## Absolute Maximum Ratings, 0 °C ≤ T<sub>J</sub> ≤ 70 °C (Unless Otherwise Noted)

Rating	Symbol	Value	Unit
Repetitive peak off-state voltage, V <sub>GK</sub> = 0	V <sub>DRM</sub>	-170	V
Repetitive peak gate-cathode voltage, V <sub>KA</sub> = 0	V <sub>GKRM</sub>	-167	V
Non-repetitive peak on-state pulse current (see Notes 1 and 2) 10/1000 (Telcordia (Bellcore) GR-1089-CORE, Issue 2, February 1999, Section 4) 5/320 (ITU-T K.20, K.21 & K.45, K.44 open-circuit voltage wave shape 10/700) 2/10 (Telcordia (Bellcore) GR-1089-CORE, Issue 2, February 1999, Section 4)	I <sub>PPSM</sub>	25 40 90	A
Non-repetitive peak on-state current, 50 Hz/60 Hz (see Notes 1 and 2) 0.1 s 1 s 5 s 300 s 900 s	I <sub>TSM</sub>	7 2.7 1.5 0.45 0.43	A
Non-repetitive peak gate current, 1/2 μs pulse, cathodes commoned (see Note 1)	I <sub>GSM</sub>	+25	A
Operating free-air temperature range	T <sub>A</sub>	-40 to +85	°C
Junction temperature	T <sub>J</sub>	-40 to +150	°C
Storage temperature range	T <sub>stg</sub>	-40 to +150	°C

- NOTES: 1. Initially, the protector must be in thermal equilibrium. The surge may be repeated after the device returns to its initial conditions. Gate voltage range is -20 V to -155 V.
2. These non-repetitive rated currents are peak values for either polarity. The rated current values may be applied to any cathode-anode terminal pair. Additionally, all cathode-anode terminal pairs may have their rated current values applied simultaneously (in this case the anode terminal current will be four times the rated current value of an individual terminal pair).

## Recommended Operating Conditions

Component		Min	Typ	Max	Unit
C <sub>G</sub>	Gate decoupling capacitor	100	220		nF
R <sub>S</sub>	Series resistor for GR-1089-CORE intra-building surge survival, section 4.5.9, tests 1 and 2	5	50		Ω
	Series resistor for K.20, K.21 and K.45 coordination with a 400 V primary protector	10	50		Ω

MARCH 2002 – REVISED JULY 2008

Specifications are subject to change without notice.

Customers should verify actual device performance in their specific applications.

# TISP6NTP2C High Voltage Ringing SLIC Protector

# BOURNS®

## Electrical Characteristics, $0\text{ }^{\circ}\text{C} \leq T_J \leq 70\text{ }^{\circ}\text{C}$ (Unless Otherwise Noted)

Parameter		Test Conditions	Min	Typ	Max	Unit
$I_D$	Off-state current	$V_D = V_{DRM}, V_{GK} = 0$			$T_J = 25\text{ }^{\circ}\text{C}$	$\mu\text{A}$
					-50	$\mu\text{A}$
$V_{(BO)}$	Ramp breakover voltage	UL 497B, $dv/dt \leq \pm 100\text{ V}/\mu\text{s}$ , $di/dt = \pm 10\text{ A}/\mu\text{s}$ , $V_{GG} = -100\text{ V}$ , Maximum ramp value = $\pm 10\text{ A}$			-112	V
$V_{(BO)}$	Impulse breakover voltage	$2/10\text{ }\mu\text{s}$ , $I_{TM} = -27\text{ A}$ , $di/dt = -27\text{ A}/\mu\text{s}$ , $R_S = 50\text{ }\Omega$ , $V_{GG} = -100\text{ V}$ , (see Note 3)			-115	V
$V_{GK(BO)}$	Gate-cathode impulse breakover voltage	$2/10\text{ }\mu\text{s}$ , $I_{TM} = -27\text{ A}$ , $di/dt = -27\text{ A}/\mu\text{s}$ , $R_S = 50\text{ }\Omega$ , $V_{GG} = -100\text{ V}$ , (see Note 3)			15	V
$V_F$	Forward voltage	$I_F = 5\text{ A}$ , $t_w = 200\text{ }\mu\text{s}$			3	V
$V_{FRM}$	Ramp peak forward recovery voltage	UL 497B, $dv/dt \leq \pm 100\text{ V}/\mu\text{s}$ , $di/dt = \pm 10\text{ A}/\mu\text{s}$ , Maximum ramp value = $\pm 10\text{ A}$			5	V
$V_{FRM}$	Impulse peak forward recovery voltage	$2/10\text{ }\mu\text{s}$ , $I_{TM} = -27\text{ A}$ , $di/dt = -27\text{ A}/\mu\text{s}$ , $R_S = 50\text{ }\Omega$ , (see Note 3)			12	V
$I_H$	Holding current	$I_T = -1\text{ A}$ , $di/dt = 1\text{ A}/\text{ms}$ , $V_{GG} = -100\text{ V}$	-150			mA
$I_{GKS}$	Gate reverse current	$V_{GG} = V_{GK} = V_{GKRM}, V_{KA} = 0$			$T_J = 25\text{ }^{\circ}\text{C}$	$\mu\text{A}$
					-50	$\mu\text{A}$
$I_{GT}$	Gate trigger current	$I_T = -3\text{ A}$ , $t_{p(g)} \geq 20\text{ }\mu\text{s}$ , $V_{GG} = -100\text{ V}$			$T_J = 25\text{ }^{\circ}\text{C}$	5
					6	mA
$V_{GT}$	Gate-cathode trigger voltage	$I_T = -3\text{ A}$ , $t_{p(g)} \geq 20\text{ }\mu\text{s}$ , $V_{GG} = -100\text{ V}$			2.5	V
$C_{KA}$	Cathode-anode off-state capacitance	$f = 1\text{ MHz}$ , $V_d = 1\text{ V}$ , $I_G = 0$ , (see Note 4)			$V_D = -3\text{ V}$	100
					$V_D = -48\text{ V}$	50
						pF

NOTES: 3. GR-1089-CORE intra-building 2/10, 1.5 kV conditions with 20 MHz bandwidth. The diode forward recovery and the thyristor gate impulse breakover (overshoot) are not strongly dependent of the SLIC supply voltage value ( $V_{GG}$ ).

4. These capacitance measurements employ a three terminal capacitance bridge incorporating a guard circuit. The unmeasured device terminals are a.c. connected to the guard terminal of the bridge.

## Thermal Characteristics

Parameter		Test Conditions	Min	Typ	Max	Unit
$R_{\theta JA}$	Junction to free air thermal resistance	$T_A = 70\text{ }^{\circ}\text{C}$ , EIA/JESD51-3 PCB, EIA/JESD51-2 environment, $P_{tot} = 0.52\text{ W}$			160	$^{\circ}\text{C}/\text{W}$

MARCH 2002 – REVISED JULY 2008

Specifications are subject to change without notice.

Customers should verify actual device performance in their specific applications.

## Parameter Measurement Information

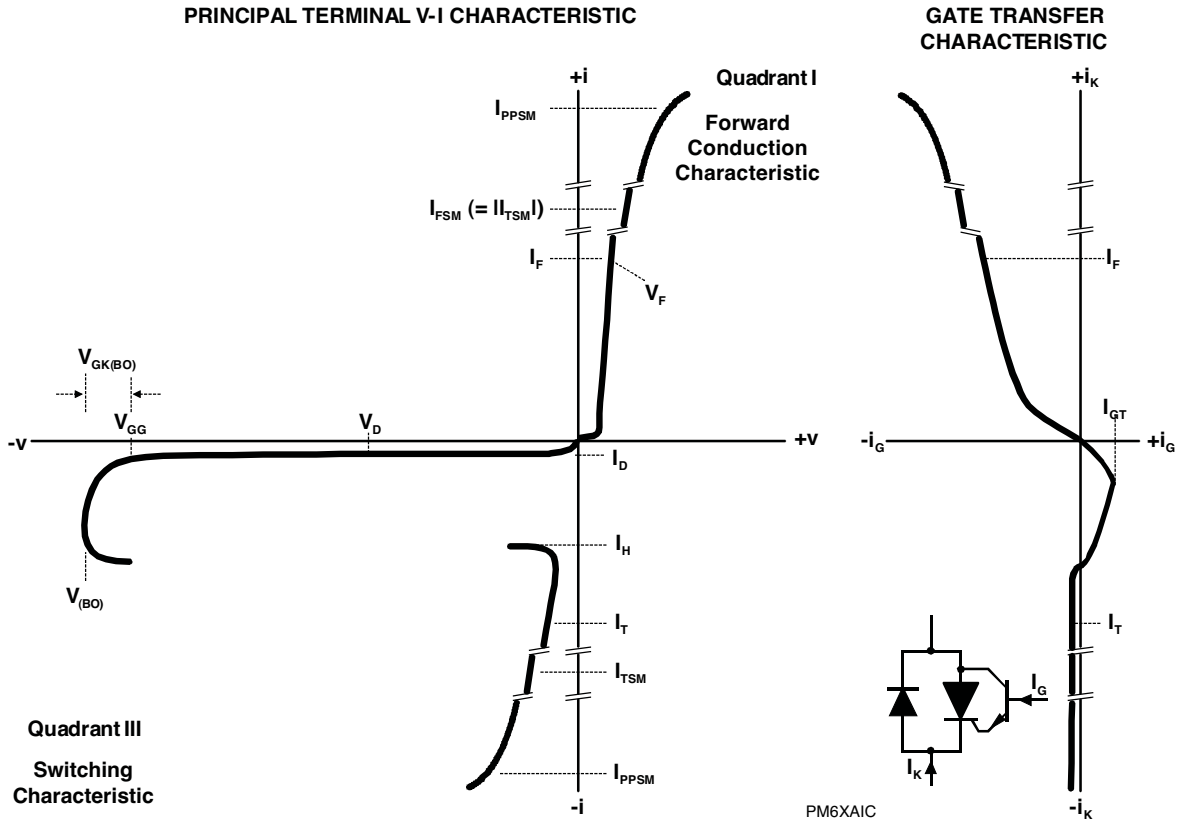

Figure 1. Principal Terminal and Gate Transfer Characteristics

## APPLICATIONS INFORMATION

### SLIC Protection

The generation of POTS lines at the customer premise normally uses a ringing SLIC. Although the lines are short, a central office ringing voltage level is often required for fax machine operation. High voltage SLICs are now available that can produce adequate ringing voltage (see table). The TISP6NTP2C has been designed to work with these SLICs which use battery voltages,  $V_{BATH}$ , down to -150 V. Figure 2 shows a typical example with one TISP6NTP2C protecting two SLICs.

The table below shows some details of HV SLICs using multiple negative supply rails.

Manufacturer	INFINEON‡	LEGERITY™‡				Unit
	SLIC-P‡	ISLIC™‡				
SLIC #	PEB 4266	79R241	79R101	79R100		
Data Sheet Issue	14/02/2001	-/08/2000	-/07/2000	-/07/2000		
Short Circuit Current	110	150	150	150	mA	
$V_{BATH}$ max.	-155	-104	-104	-104	V	
$V_{BATL}$ max.	-150	-104	$V_{BATH}$	$V_{BATH}$	V	
AC Ringing for:	85	45†	50†	55†	V rms	
Crest Factor	1.4	1.4	1.4	1.25		
$V_{BATH}$	-70	-90	-99	-99	V	
$V_{BATR}$	-150	-36	-24	-24	V	
R or T Overshoot < 250 ns		-15   15	-20   12	-20   12	V	
Line Feed Resistance	20 + 30	50	50	50	Ω	

† Assumes -20 V battery voltage during ringing.

‡ Legerity, the Legerity logo and ISLIC are the trademarks of Legerity, Inc.

Other product names used in this publication are for identification purposes only and may be trademarks of their respective companies.

### ISDN Protection

For voltage feed protection, the cathodes of an TISP6NTP2C thyristors are connected to the four conductors to be protected (see Figure 3). Each gate is connected to the appropriate negative voltage feed. The anode of the TISP6NTP2C is connected to the system common. Positive overvoltages are clipped to common by forward conduction of the TISP6NTP2C antiparallel diode. Negative overvoltages are initially clipped close to the negative supply by emitter follower action of the TISP6NTP2C buffer transistor. If sufficient clipping current flows, the TISP6NTP2C thyristor will regenerate and switch into a low voltage on-state condition. As the negative overvoltage subsides, the high holding current of the TISP6NTP2C prevents d.c. latchup.

### Voltage Stress Levels

Figure 4 shows the protector electrodes. The package terminal designated gate, G, is the transistor base, B, electrode connection and so is marked as B (G). The following junctions are subject to voltage stress: Transistor EB and CB, SCR AK (off state) and the antiparallel diode (reverse blocking). This clause covers the necessary testing to ensure the junctions are good.

Testing transistor CB and EB: The maximum voltage stress level for the TISP6NTP2C is  $V_{BATH}$  with the addition of the short term antiparallel diode voltage overshoot,  $V_{FRM}$ . The current flowing out of the G terminal is measured at  $V_{BATH}$  plus  $V_{FRM}$ . The SCR K terminal is shorted to the common (0 V) for this test (see Figure 4). The measured current,  $I_{GKS}$ , is the sum of the junction currents  $I_{CB}$  and  $I_{EB}$ .

Testing transistor CB, SCR AK off state and diode reverse blocking: The highest AK voltage occurs during the overshoot period of the protector. To make sure that the SCR and diode blocking junctions do not break down during this period, a d.c. test for off-state current,  $I_D$ , can be applied at the overshoot voltage value. To avoid transistor CB current amplification by the transistor gain, the transistor base-emitter is shorted during this test (see Figure 5).

Summary: Two tests are need to verify the protector junctions. Maximum current values for  $I_{GKS}$  and  $I_D$  are required at the specified applied voltage conditions.

MARCH 2002 – REVISED JULY 2008

Specifications are subject to change without notice.

Customers should verify actual device performance in their specific applications.

## APPLICATIONS INFORMATION

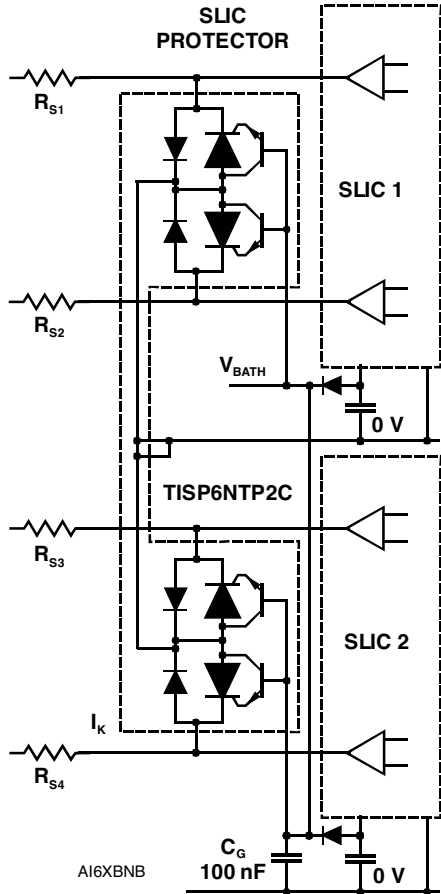
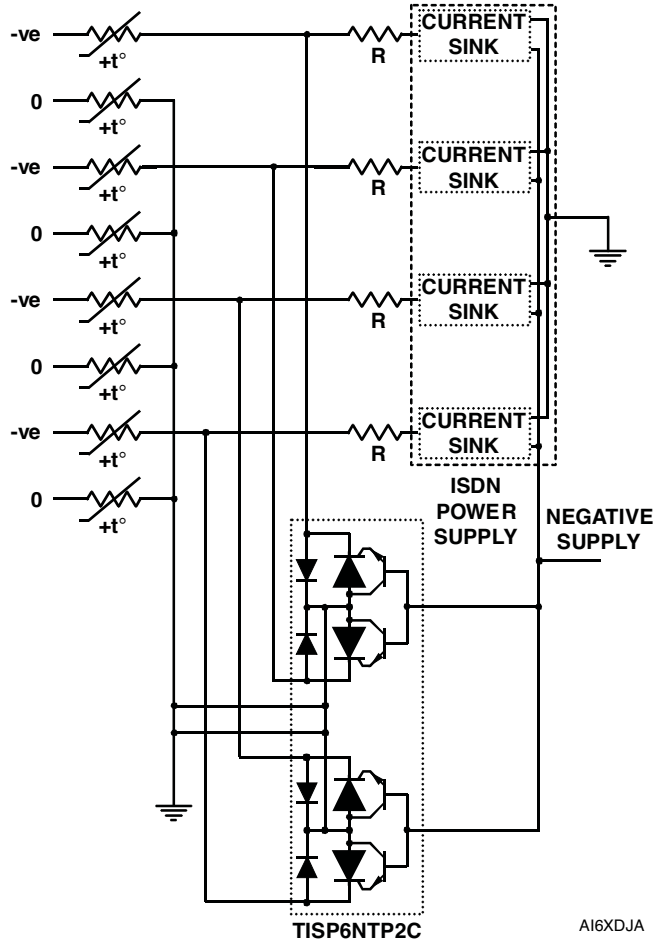

Figure 2. SLIC Protection



Resistor "R" may be needed if sink has internal clamp diode

Figure 3. Protection of Four ISDN Power Feeds

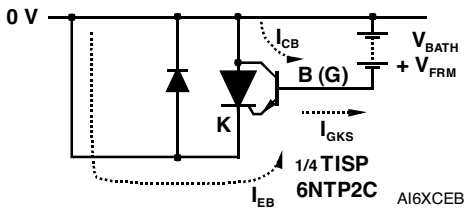

Figure 4. Transistor CB and EB Verification

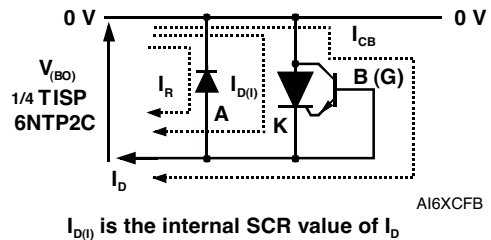

Figure 5. Off-State Current Verification

# TISP6NTP2C High Voltage Ringing SLIC Protector

**BOURNS®**

## MECHANICAL DATA

### Device Symbolization Code

Devices will be coded as below.

Device	Symbolization Code
TISP6NTP2CDR-S	6NTP2C

"TISP" is a trademark of Bourns, Ltd., a Bourns Company, and is Registered in U.S. Patent and Trademark Office.  
"Bourns" is a registered trademark of Bourns, Inc. in the U.S. and other countries.

MARCH 2002 – REVISED JULY 2008

Specifications are subject to change without notice.

Customers should verify actual device performance in their specific applications.

Компания «Life Electronics» занимается поставками электронных компонентов импортного и отечественного производства от производителей и со складов крупных дистрибьюторов Европы, Америки и Азии.

С конца 2013 года компания активно расширяет линейку поставок компонентов по направлению коаксиальный кабель, кварцевые генераторы и конденсаторы (керамические, пленочные, электролитические), за счёт заключения дистрибьюторских договоров

Мы предлагаем:

- Конкурентоспособные цены и скидки постоянным клиентам.
- Специальные условия для постоянных клиентов.
- Подбор аналогов.
- Поставку компонентов в любых объемах, удовлетворяющих вашим потребностям.
- Приемлемые сроки поставки, возможна ускоренная поставка.
- Доставку товара в любую точку России и стран СНГ.
- Комплексную поставку.
- Работу по проектам и поставку образцов.
- Формирование склада под заказчика.
- Сертификаты соответствия на поставляемую продукцию (по желанию клиента).
- Тестирование поставляемой продукции.
- Поставку компонентов, требующих военную и космическую приемку.
- Входной контроль качества.
- Наличие сертификата ISO.

В составе нашей компании организован Конструкторский отдел, призванный помогать разработчикам, и инженерам.

Конструкторский отдел помогает осуществить:

- Регистрацию проекта у производителя компонентов.
- Техническую поддержку проекта.
- Защиту от снятия компонента с производства.
- Оценку стоимости проекта по компонентам.
- Изготовление тестовой платы монтаж и пусконаладочные работы.



Тел: +7 (812) 336 43 04 (многоканальный)

Email: [org@lifeelectronics.ru](mailto:org@lifeelectronics.ru)