

USB3.0 and USB2.0 Combo Switch

Features

- 1:2 mux/demux for USB 3.0SS, 2.0HS, and 2.0FS signals
- Switches Tx, Rx, Dx, and USB_ID from USB3.0 connector
- Insertion Loss for superspeed channels @ 2.5 GHz: -1.7dB
- -3dB Bandwidth for superspeed channels: 4.7GHz
- Return loss for superspeed channels @ 2.5GHz: -16dB
- Low Bit-to-Bit Skew, 7ps max (between '+' and '-' bits)
- Low Crosstalk for superspeed channels: -25dB@5.0 Gbps
- Low Off Isolation for superspeed channels: -25dB@5.0 Gbps
- V_{DD} Operating Range: 3.3V +/-10%
- ESD Tolerance: 2kV HBM
- Low channel-to-channel skew, 35ps max
- Packaging (Pb-free & Green):
 - 32 TQFN (ZL)

Description

Pericom Semiconductor's PI3USB3102 USB3.0 and USB2.0 Combo Switch is a complete 1:2 switching solution for SuperSpeed USB 3.0 signals. PI3USB3102 provides differential high-speed lanes for the USB3.0 4.8 Gbps TX and RX lanes as well as a differential lane for 480 Mbps USB 2.0 signals and the USB_ID signal.

PI3USB3102 can be used to connect two hosts to a single device or a single host to two devices.

PI3USB3102 offers excellent signal integrity for high-speed signals and low power dissipation. Insertion loss is 1.7 dB and return loss is -16 dB at 2.5 GHz. Power dissipation is 6.6 mW maximum.

Application

Routing of USB3.0 signals with low signal attenuation between source and sink.

Block Diagram

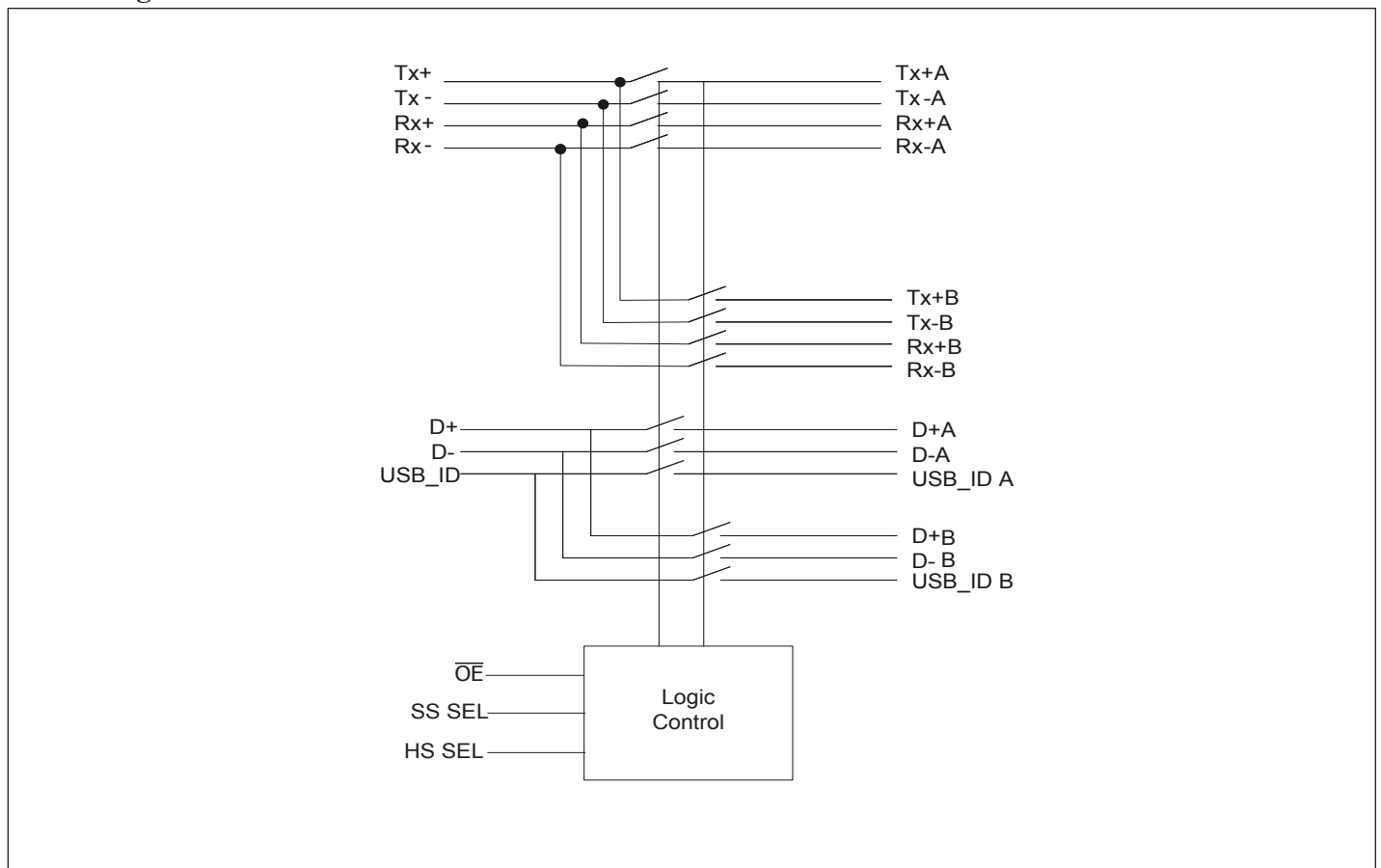

Pin Assignment (TQFN-32)

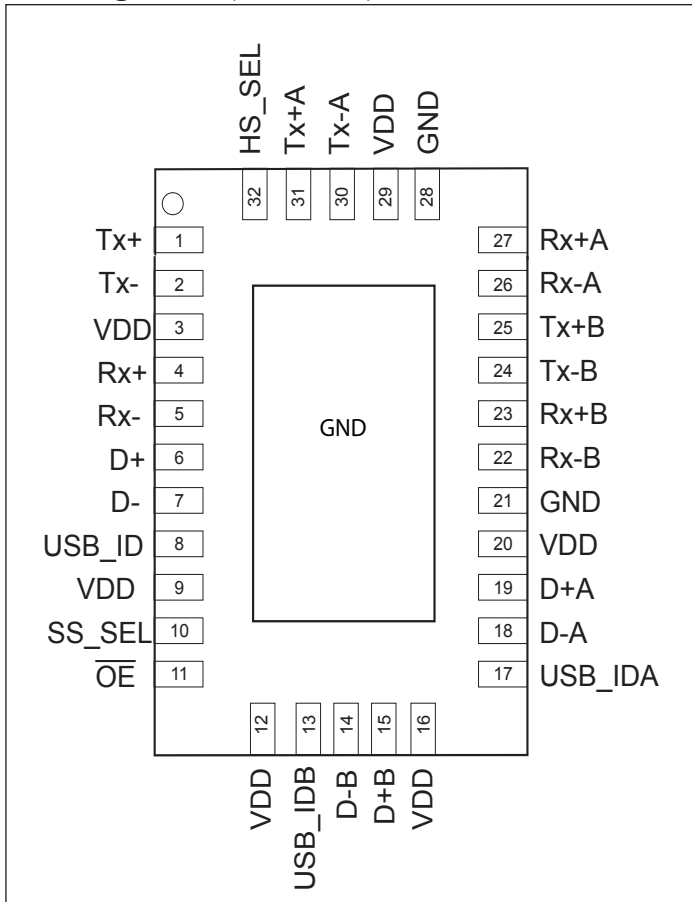

Truth Table

\overline{OE}	SS_SEL	HS_SEL	Function
Low	Low	Low	Port A active for all channels
Low	Low	High	Port A for SS, port B for HS and ID
Low	High	Low	Port B for SS, port A for HS and ID
Low	High	High	Port B active for all channels
High	x	x	I/O's are hi-z and IC is power down

Pin Description

pin#	pin Name	Signal Type	Description
1	Tx+	I/O	positive differential USB3.0 Tx signal for COM port
2	Tx-	I/O	negative differential USB3.0 Tx signal for COM port
3	VDD	Power	3.3V +/-10% power supply
4	Rx+	I/O	positive differential USB3.0 Rx signal for COM port
5	Rx-	I/O	negative differential USB3.0 Rx signal for COM port
6	D+	I/O	positive differential USB2.0 signal for COM port
7	D-	I/O	negative differential USB2.0 signal for COM port
8	USB_ID	I/O	USB_ID for COM port
9	VDD	Power	3.3V +/-10% power supply
10	SS_SEL	I	switch logic control for SuperSpeed Path If HIGH, then path B is selected for SuperSpeed channels only If LOW, then path A is selected for SuperSpeed channels only
11	\overline{OE}	I	Output enable. if \overline{OE} is low, IC is enabled. If \overline{OE} is high, then IC is power down and all I/Os are hi-z
12	VDD	Power	3.3V +/-10% power supply
13	USB_IDB	I/O	USB_ID for port B
14	D-B	I/O	negative differential USB2.0 signal for port B
15	D+B	I/O	positive differential USB2.0 signal for port B
16	VDD	Power	3.3V +/-10% power supply
17	USB_IDA	I/O	USB_ID for port A
18	D-A	I/O	negative differential USB2.0 signal for port A
19	D+A	I/O	positive differential USB2.0 signal for port A
20	VDD	Power	3.3V +/-10% power supply
21	GND	Ground	Ground
22	Rx-B	I/O	negative differential USB3.0 Rx signal for port B
23	Rx+B	I/O	positive differential USB3.0 Rx signal for port B
24	Tx-B	I/O	negative differential USB3.0 Tx signal for port B
25	Tx+B	I/O	positive differential USB3.0 Tx signal for port B
26	Rx-A	I/O	negative differential USB3.0 Rx signal for port A
27	Rx+A	I/O	positive differential USB3.0 Rx signal for port A
28	GND	Ground	Ground
29	VDD	Power	3.3V +/-10% power supply
30	Tx-A	I/O	negative differential USB3.0 Tx signal for port A
31	Tx+A	I/O	positive differential USB3.0 Tx signal for port A
32	HS_SEL	I	switch logic control for USB2.0 (D+/-) and USB_ID path If High, path B is selected If LOW, path A is selected

Maximum Ratings

(Above which useful life may be impaired. For user guidelines, not tested.)

Storage Temperature	-65°C to +150°C
Supply Voltage to Ground Potential	-0.5V to +4.2V
DC Input Voltage	-0.5V to V _{DD}
DC Output Current	120mA
Power Dissipation	0.5W

Note: Stresses greater than those listed under MAXIMUM RATINGS may cause permanent damage to the device. This is a stress rating only and functional operation of the device at these or any other conditions above those indicated in the operational sections of this specification is not implied. Exposure to absolute maximum rating conditions for extended periods may affect reliability.

DC Electrical Characteristics for Switching over Operating Range

(T_A = -40°C to +85°C, V_{DD} = 3.3V ±10%)

Parameter	Description	Test Conditions ⁽¹⁾	Min	Typ ⁽¹⁾	Max	Units
V _{IH}	Input HIGH Voltage	Guaranteed HIGH level	1.5			V
V _{IL}	Input LOW Voltage	Guaranteed LOW level			0.75	
V _{IK}	Clamp Diode Voltage, Dx	V _{DD} = Max., I _{IN} = -18mA		-0.8	-1.1	
I _{IH}	Input HIGH Current	V _{DD} = Max., V _{IN} = V _{DD}			±5	µA
I _{IL}	Input LOW Current	V _{DD} = Max., V _{IN} = GND			±5	
I _{OFF_HS/ID}	I/O leakage when part is off for D+, D- and USB_ID signals only	V _{DD} = 0V, V _{INPUT} = 0V to 3.6V			20	
R _{ON_SS}	On resistance between input to output for SuperSpeed signals	V _{DD} = 3.3V, V _{input} = 0V to 1V, I _{INPUT} = 20mA		10	13	Ohm
R _{ON_FS}	On resistance between input to output for USB2.0 FS signals (D+/D-)	V _{DD} = 3.3V, V _{input} = 0 to 3.3V, I _{INPUT} = 20mA		7	9	Ohm
R _{ON_HS}	On resistance between input to output for USB2.0 HS signals (D+/D-)	V _{DD} = 3.3V, V _{input} = -0.4V to +0.4V, I _{INPUT} = 20mA		4	6	Ohm
USB_ID_I	Input voltage tolerance on USB_ID path				5.5	V
USB_ID_O	Output voltage on USB_ID path	USB_ID input from 0V to 5.25V			3.6	V

Power Supply Characteristics (T_A = -40°C to +85°C)

Parameter	Description	Test Conditions ⁽¹⁾	Min	Typ ⁽¹⁾	Max	Units
I _{CC}	Quiescent Power Supply Current	V _{DD} = Max., V _{IN} = GND or V _{DD}			2	mA

Dynamic Electrical Characteristics over Operating Range ($T_A = -40^\circ \text{ to } +85^\circ \text{C}$, $V_{DD} = 3.3\text{V} \pm 10\%$)

Parameter	Description	Test Conditions		Typ.	Max	Units
X_{TALK}	Crosstalk on SuperSpeed Channels	See Fig. 1 for Measurement Setup	$f = 2.5 \text{ GHz}$	-25dB		dB
O_{IRR}	OFF Isolation on SuperSpeed Channels	See Fig. 2 for Measurement Setup,	$f = 2.5 \text{ GHz}$	-22dB		
I_{LOSS}	Differential Insertion Loss on SuperSpeed Channels	@5.0Gbps (see figure 3)		-1.7		dB
R_{loss}	Differential Return Loss on SuperSpeed channels	@ 2.5GHz		-16		dB
BW_{SS}	Bandwidth -3dB for SuperSpeed path (Tx±/ Rx±)	See figure 3		4.7		GHz
BW_{HS}	-3dB BW for USB high speed path (D+/-)	See figure 3		1.5		GHz
$T_{\text{sw a-b}}$	time it takes to switch from port A to port B				1	us
$T_{\text{sw b-a}}$	time it takes to switch from port B to port A				1	us
T_{startup}	Vdd valid to channel enable				10	us
T_{wakeup}	Enabling output by changing $\overline{\text{OE}}$ from low to High				10	us

1. For Max. or Min. conditions, use appropriate value specified under Electrical Characteristics for the applicable device type.
2. Typical values are at $V_{DD} = 3.3\text{V}$, $T_A = 25^\circ \text{C}$ ambient and maximum loading.

Switching Characteristics ($T_A = -40^\circ \text{ to } +85^\circ \text{C}$, $V_{DD} = 3.3\text{V} \pm 10\%$)

Parameter	Description	Min.	Typ.	Max.	Units
T_{pd}	Propagation delay (input pin to output pin)		80		ps
$t_{\text{b-b}}$	Bit-to-bit skew within the same differential pair		5		ps
$t_{\text{ch-ch}}$	Channel-to-channel skew			35	ps

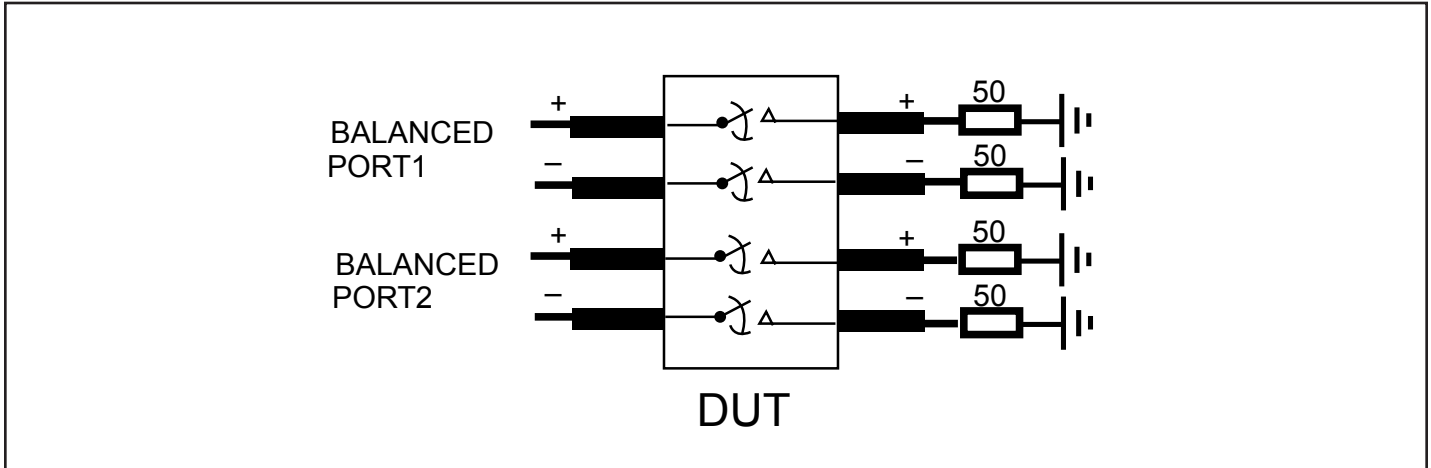

Fig 1. Crosstalk Setup

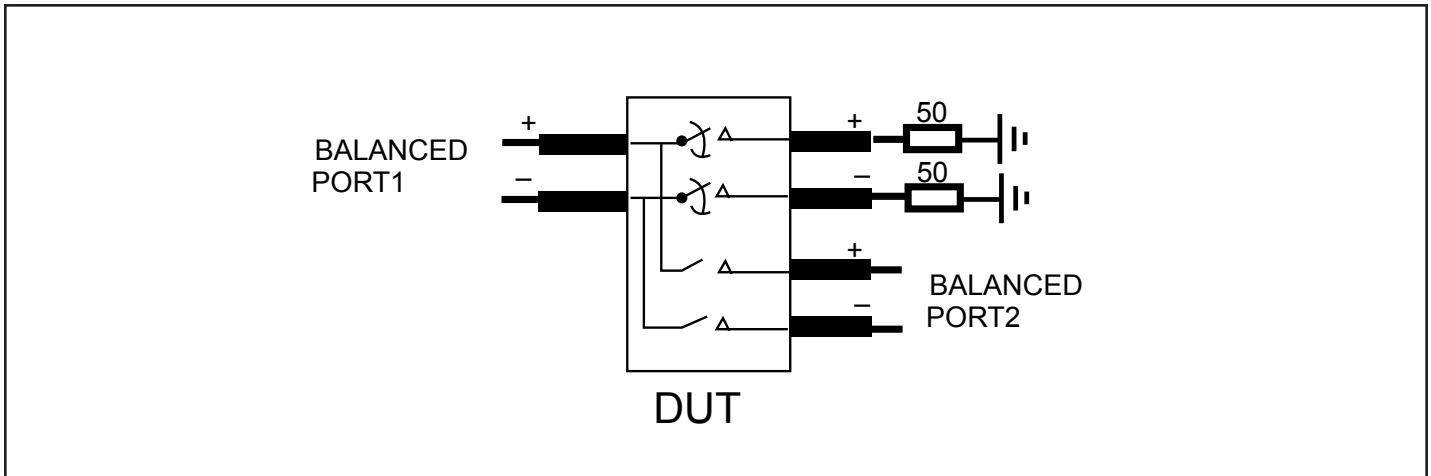

Fig 2. Off-isolation setup

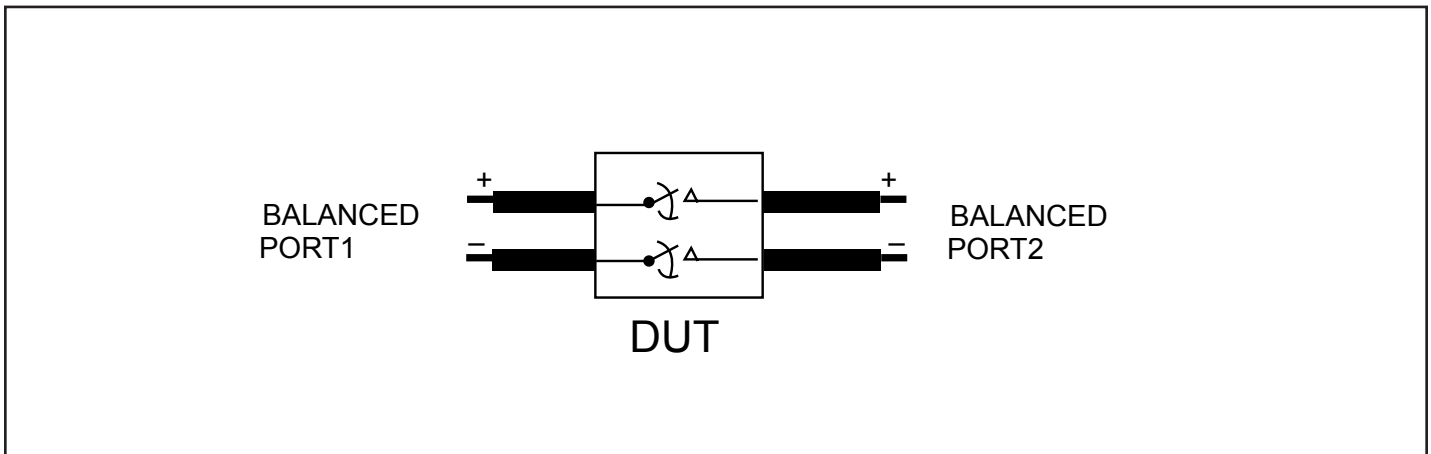

Fig 3. Differential Insertion Loss set up

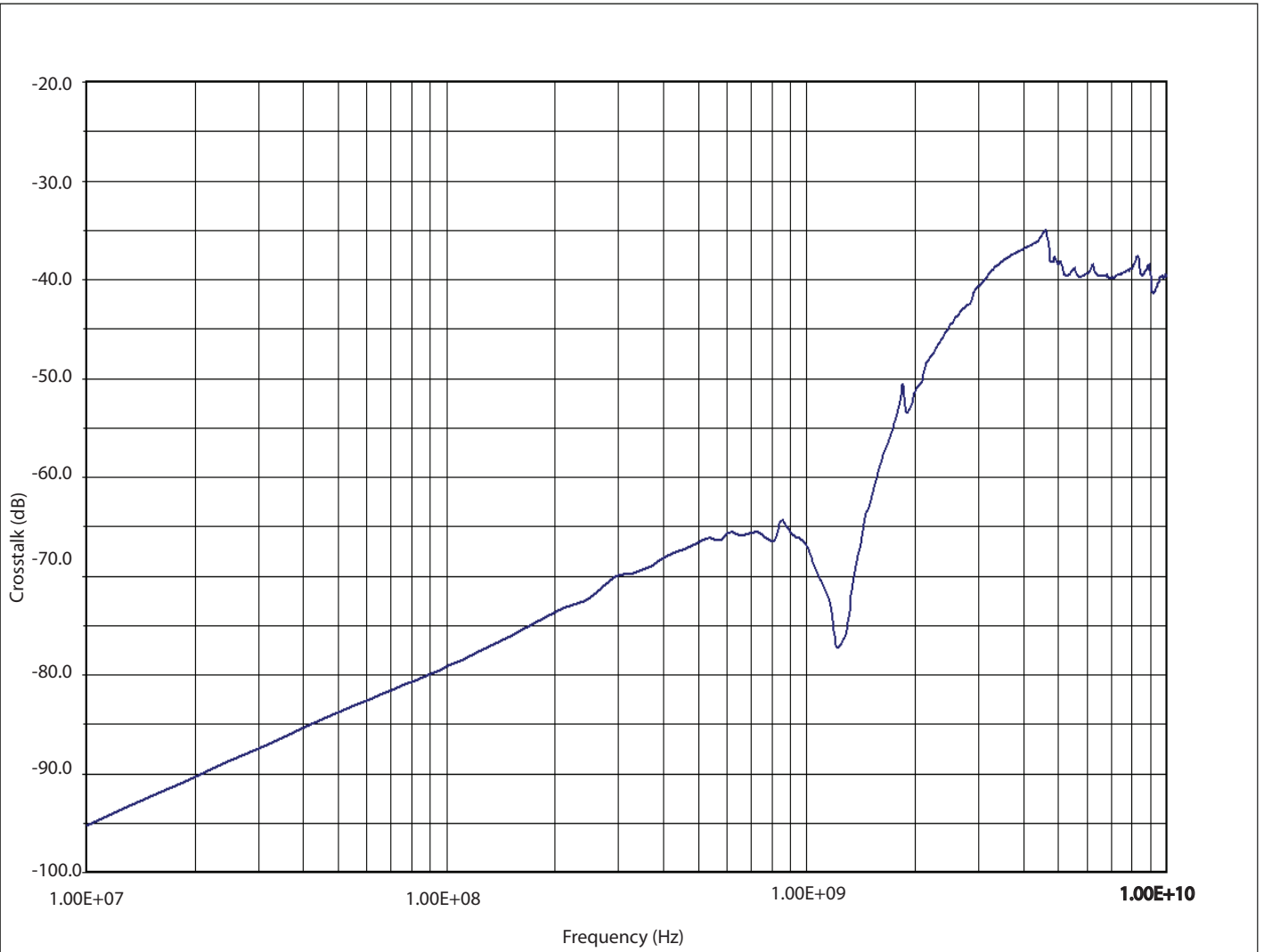

Fig 4. Xtalk for SuperSpeed channels (Tx/Rx)

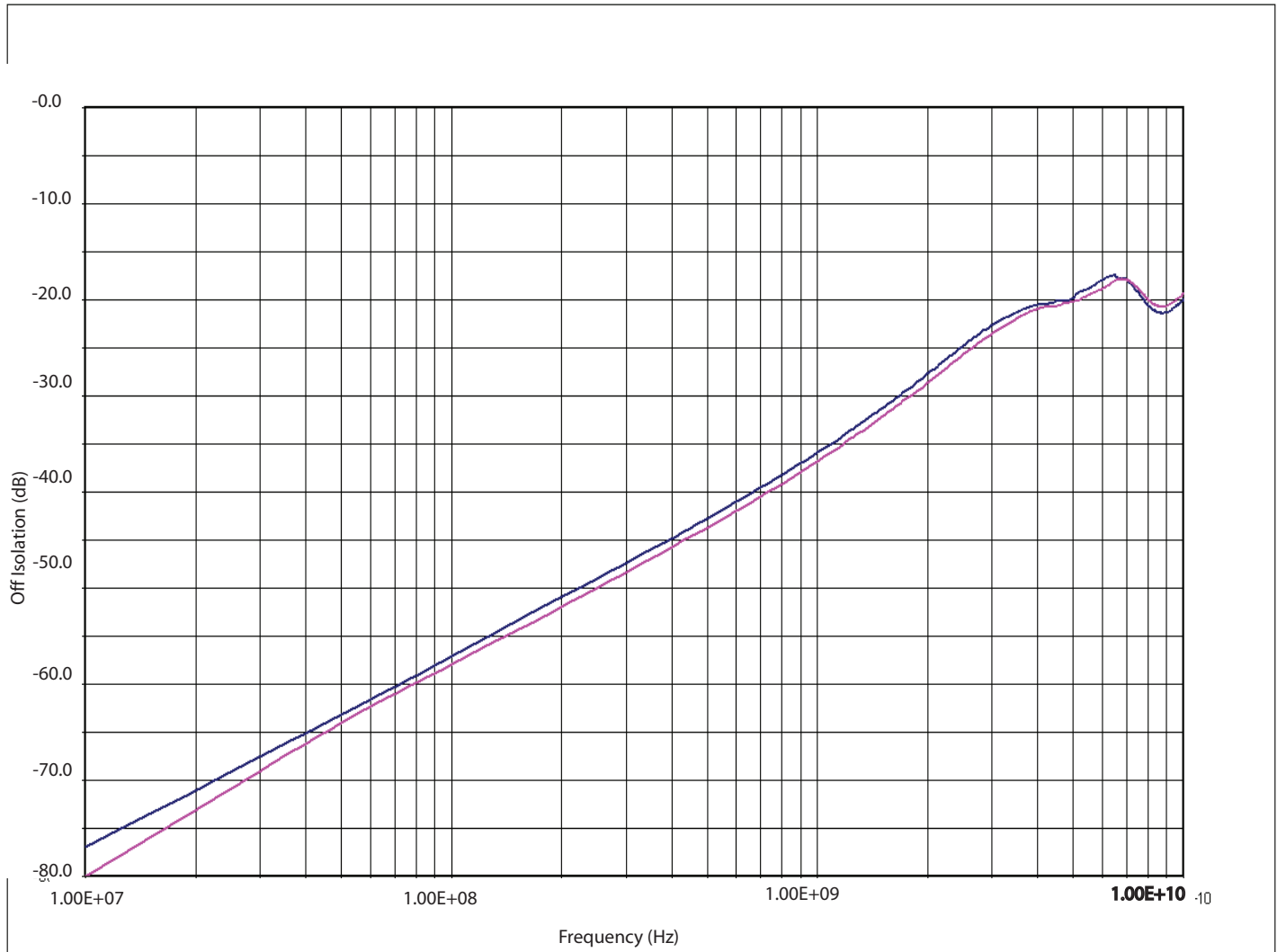

Fig 5. Off Isolation for SuperSpeed channels (Tx/Rx). Red is for path B and Blue is for path A

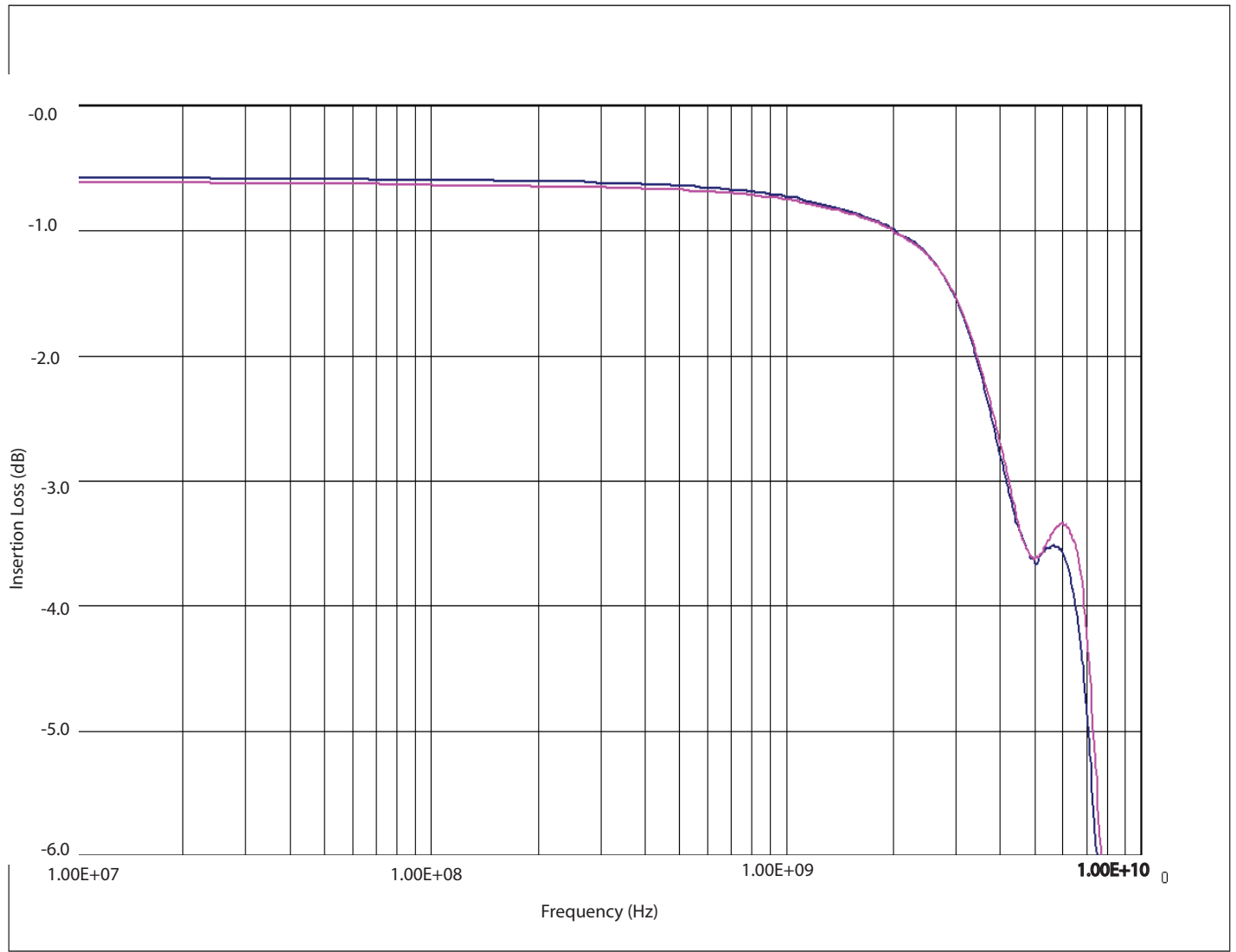
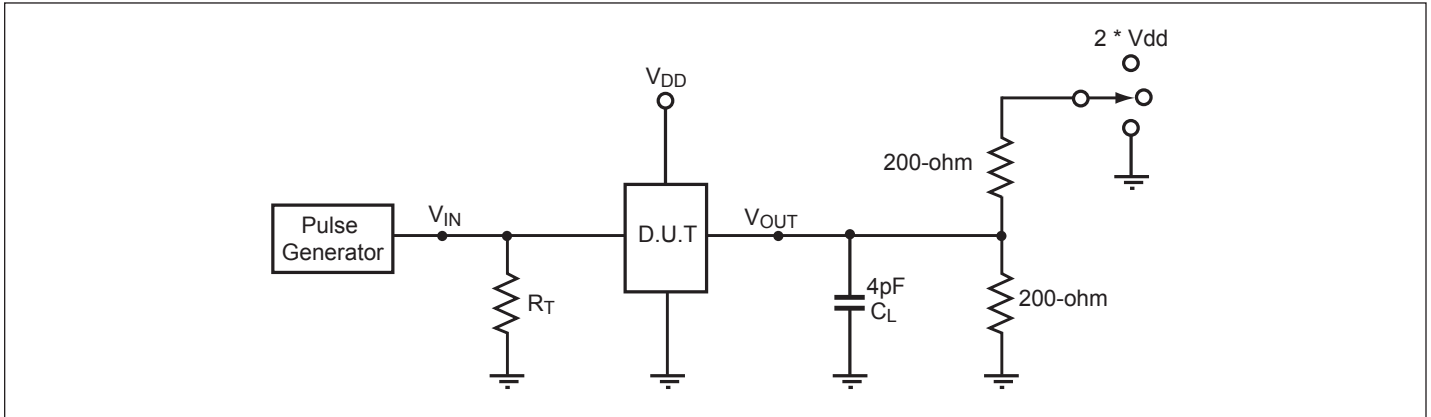

Fig 6. Insertion Loss for SuperSpeed channels (Tx/Rx). Red is for path B and Blue is for path A

Test Circuit for Electrical Characteristics(1-5)



Notes:

1. C_L = Load capacitance: includes jig and probe capacitance.
2. R_T = Termination resistance: should be equal to Z_{OUT} of the Pulse Generator
3. Output 1 is for an output with internal conditions such that the output is low except when disabled by the output control.
4. Output 2 is for an output with internal conditions such that the output is high except when disabled by the output control.
5. All input impulses are supplied by generators having the following characteristics: $PRR \leq \text{MHz}$, $Z_O = 50\Omega$, $t_R \leq 2.5\text{ns}$, $t_F \leq 2.5\text{ns}$.
6. The outputs are measured one at a time with one transition per measurement.

Switching Waveforms

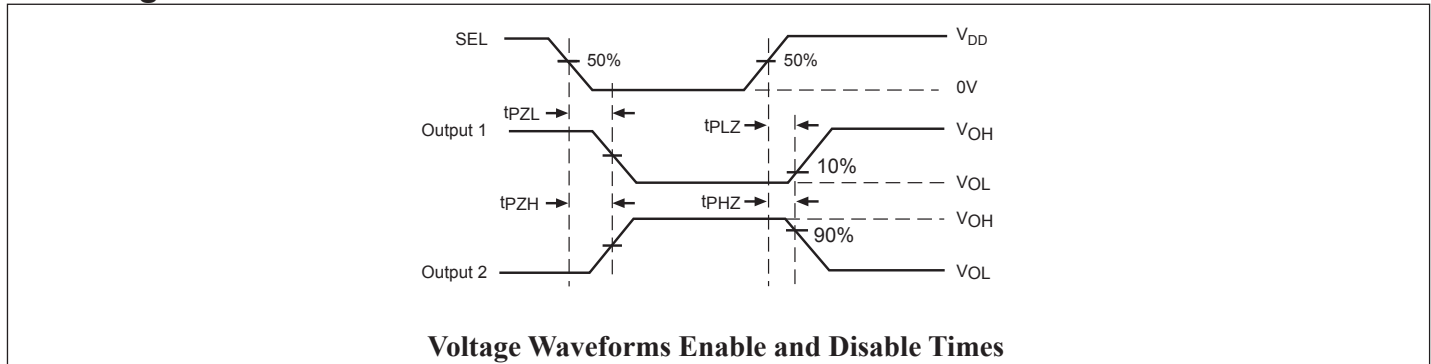

Switch Positions

Test	Switch
t_{PLZ} , t_{PZL} (output on B-side)	2 * Vdd
t_{PHZ} , t_{PZH} (output on B-side)	GND
Prop Delay	Open

Test Circuit for Dynamic Electrical Characteristics

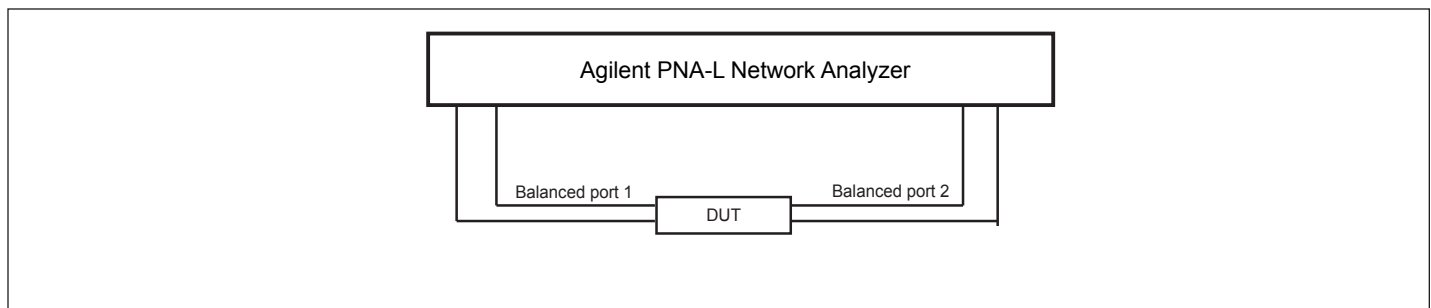

Packaging Mechanical: 32-Contact TQFN (ZL)

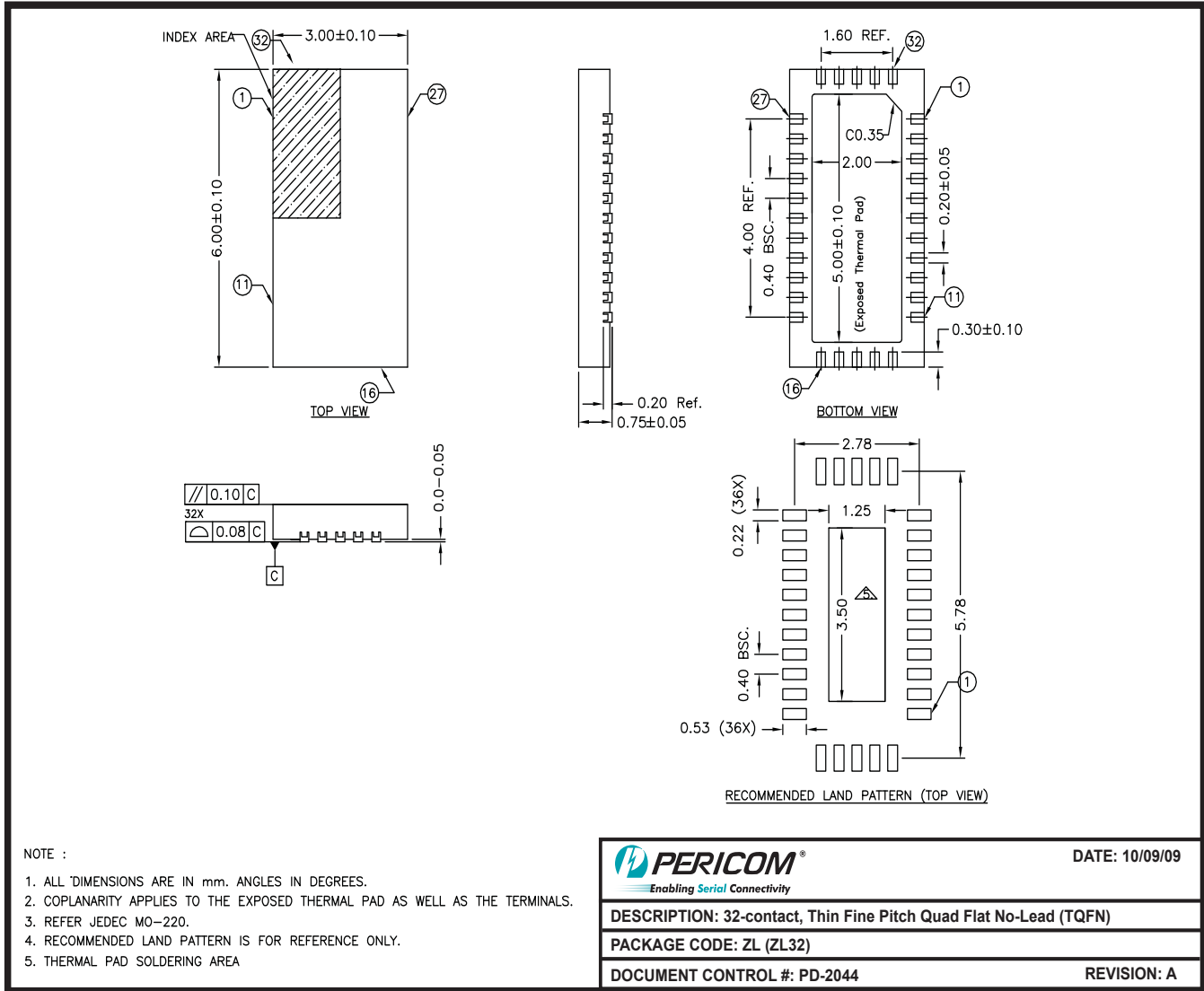

09-0125

Note:

For latest package info, please check: <http://www.pericom.com/products/packaging/mechanicals.php>

Ordering Information

Ordering Code	Package Code	Package Description
PI3USB3102ZLE	ZL	Pb-free & Green, 32-contact TQFN, Copper Wire
PI3USB3102ZLE+DA	ZL	Pb-free & Green, 32-contact TQFN, Gold Wire

Notes:

- Thermal characteristics can be found on the company web site at www.pericom.com/packaging/
- "E" denotes Pb-free and Green
- Adding an "X" at the end of the ordering code denotes tape and reel packaging

Mouser Electronics

Authorized Distributor

Click to View Pricing, Inventory, Delivery & Lifecycle Information:

[Diodes Incorporated:](#)

[PI3USB3102ZLEX](#) [PI3USB3102ZLE](#) [PI3USB3102QZLEX](#)

Компания «Life Electronics» занимается поставками электронных компонентов импортного и отечественного производства от производителей и со складов крупных дистрибьюторов Европы, Америки и Азии.

С конца 2013 года компания активно расширяет линейку поставок компонентов по направлению коаксиальный кабель, кварцевые генераторы и конденсаторы (керамические, пленочные, электролитические), за счёт заключения дистрибьюторских договоров

Мы предлагаем:

- Конкуренеспособные цены и скидки постоянным клиентам.
- Специальные условия для постоянных клиентов.
- Подбор аналогов.
- Поставку компонентов в любых объемах, удовлетворяющих вашим потребностям.
- Приемлемые сроки поставки, возможна ускоренная поставка.
- Доставку товара в любую точку России и стран СНГ.
- Комплексную поставку.
- Работу по проектам и поставку образцов.
- Формирование склада под заказчика.
- Сертификаты соответствия на поставляемую продукцию (по желанию клиента).
- Тестирование поставляемой продукции.
- Поставку компонентов, требующих военную и космическую приемку.
- Входной контроль качества.
- Наличие сертификата ISO.

В составе нашей компании организован Конструкторский отдел, призванный помогать разработчикам, и инженерам.

Конструкторский отдел помогает осуществить:

- Регистрацию проекта у производителя компонентов.
- Техническую поддержку проекта.
- Защиту от снятия компонента с производства.
- Оценку стоимости проекта по компонентам.
- Изготовление тестовой платы монтаж и пусконаладочные работы.



Тел: +7 (812) 336 43 04 (многоканальный)
Email: org@lifeelectronics.ru