

MAX14617

USB Host Charger Identification/Adapter Emulator

General Description

The MAX14617 is a third-generation USB 2.0 host charger identification device that combines USB Hi-Speed analog switches with a USB adapter emulator circuit.

The device supports pass-through mode and auto mode. In charging downstream port (CDP) pass-through mode, the device emulates the CDP function while supporting normal USB traffic.

The device also supports charging downstream port (CDP) and standard downstream port (SDP) charging during the active state (S0). The MAX14617 also supports dedicated charging port (DCP) charging during the standby state (S3/S4/S5).

The MAX14617 is available in an 8-pin (2mm x 2mm) TDFN package, and is specified over the -40°C to +85°C extended temperature range.

Applications

USB Host Data/Chargers Including:	Flat-Panel Displays with USB
Laptop and Desktop Computers	Media Players
USB Hubs	Game Consoles

Benefits and Features

- ◆ **Improved Charger Interoperability**
 - ◇ USB Charger Downstream Port (CDP) Emulation in S0 State
 - ◇ Meets New USB Battery Charging (BC) Revision 1.2 Specification
 - ◇ Backward Compatible with Previous USB BC Revisions
 - ◇ Meets China YD/T1591-2009 Charging Specification
 - ◇ Supports Standby Mode Charging for Apple BC Revision 1.2-Compatible Devices
- ◆ **Greater User Flexibility**
 - ◇ CB0, CB1, and CB2 Pins Control Multiple Automatic and Manual Charger States
- ◆ **High Level of Integrated Features**
 - ◇ Low-Capacitance USB 2.0 Hi-Speed Switch to Change Charging Modes
 - ◇ Automatic Current-Limit Switch Control
- ◆ **Saves Space on Board**
 - ◇ 2mm x 2mm, 8-Pin TDFN Package

Ordering Information appears at end of data sheet.

Typical Operating Circuit

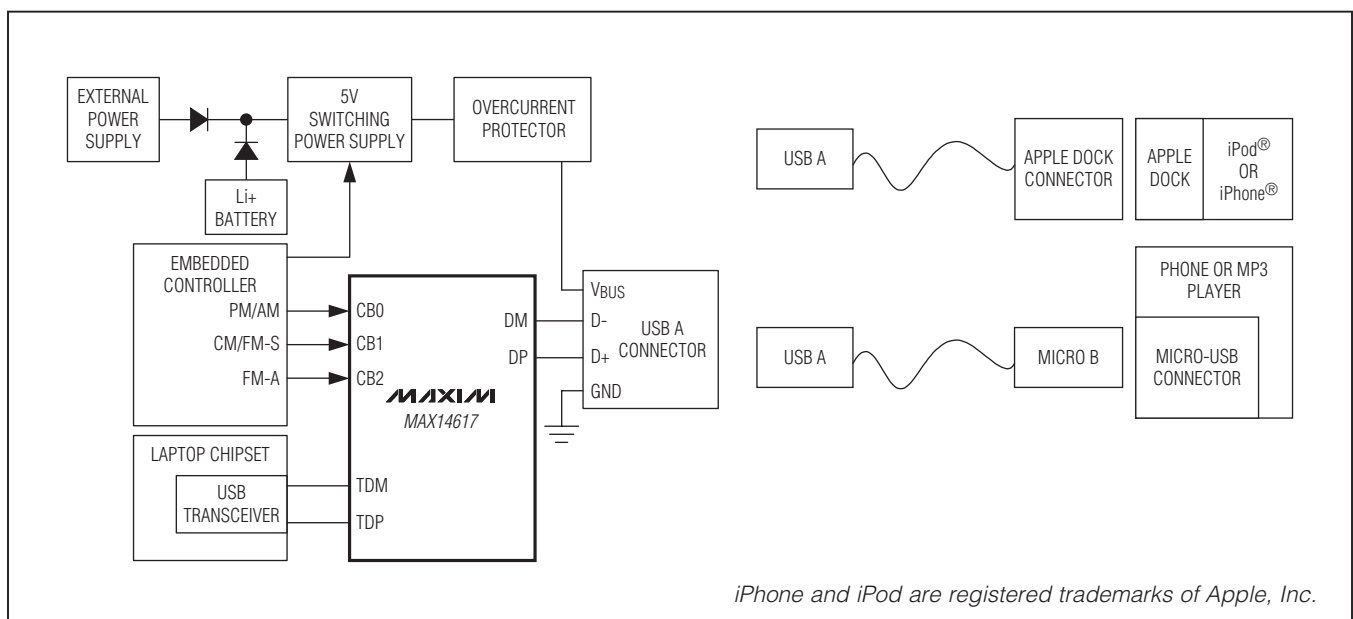

USB Host Charger Identification/Adapter Emulator

ABSOLUTE MAXIMUM RATINGS

(All voltages referenced to GND.)

V_{CC}, TDP, TDM, CB0, CB1, CB2, DP, DM -0.3V to +6.0V
 Continuous Current into Any Terminal ±30mA
 Continuous Power Dissipation (T_A = +70°C)
 TDFN (derate 11.9mW/°C above +70°C).....953.5mW

Operating Temperature Range -40°C to +85°C
 Junction Temperature +150°C
 Storage Temperature Range..... -65°C to +150°C
 Lead Temperature (soldering, 10s) +300°C
 Soldering Temperature (reflow) +260°C

Stresses beyond those listed under "Absolute Maximum Ratings" may cause permanent damage to the device. These are stress ratings only, and functional operation of the device at these or any other conditions beyond those indicated in the operational sections of the specifications is not implied. Exposure to absolute maximum rating conditions for extended periods may affect device reliability.

PACKAGE THERMAL CHARACTERISTICS (Note 1)

TDFN

Junction-to-Ambient Thermal Resistance (θ_{JA})84°C/W
 Junction-to-Case Thermal Resistance (θ_{JC})37°C/W

Note 1: Package thermal resistances were obtained using the method described in JEDEC specification JESD51-7, using a four-layer board. For detailed information on package thermal considerations, refer to www.maxim-ic.com/thermal-tutorial.

ELECTRICAL CHARACTERISTICS

(V_{CC} = 3.0V to 5.5V, T_A = T_{MIN} to T_{MAX}, unless otherwise noted. Typical values are at V_{CC} = 5.0V, T_A = +25°C.) (Note 2)

PARAMETER	SYMBOL	CONDITIONS	MIN	TYP	MAX	UNITS
POWER SUPPLY						
Power-Supply Range	V _{CC}	V _{CB0} > V _{IH}	3.0		5.5	V
		V _{CB0} = 0V (Note 3)	4.75		5.25	
Supply Current	I _{CC}	V _{CB0} = V _{CB1} = V _{CC} = 5.25V, V _{CB2} = 0V, CM mode		50	100	μA
		V _{CB0} = V _{CC} = 5.25V, V _{CB1} = V _{CB2} = 0V, PM mode		4	20	
		V _{CB0} = V _{CB2} = 0V, V _{CB1} = V _{CC} = 5.25V, FM-S mode		10	50	
		V _{CB0} = V _{CB1} = 0V, AM or FM-A mode		130	200	
ANALOG SWITCH						
Analog-Signal Range	V _{DP} , V _{DM}		0		V _{CC}	V
On-Resistance TDP/TDM Switch	R _{ON}	V _{TDP} = V _{TDM} = 0V to V _{CC} , I _{TDP} = I _{TDM} = 10mA		3.5	6.5	Ω
On-Resistance Match Between Channels TDP/TDM Switch	ΔR _{ON}	V _{CC} = 5.0V, V _{DP} = V _{DM} = 400mV, I _{DP} = I _{DM} = 10mA		0.1		Ω
On-Resistance Flatness TDP/TDM Switch	R _{FLAT}	V _{CC} = 5.0V, V _{DP} = V _{DM} = 0 to V _{CC} , I _{DP} = I _{DM} = 10mA		0.1		Ω
On-Resistance of DP/DM Short	R _{SHORT}	V _{CB0} = 0V, V _{CB1} = V _{CC} , V _{CB2} = 0V, V _{DP} = 1V, R _{DM} = 20kΩ		70	120	Ω
Off-Leakage Current	I _{TDP} OFF, I _{TDM} OFF	V _{CC} = 3.6V, V _{DP} = V _{DM} = 0.3V to 3.3V, V _{TDP} = V _{TDM} = 3.3V to 0.3V	-250		+250	nA
On-Leakage Current	I _{DP} ON, I _{DM} ON	V _{CC} = 3.6V, V _{DP} = V _{DM} = 3.3V to 0.3V, V _{CB0} = V _{CC} , V _{CB1} = V _{CB2} = 0V	-250		+250	nA
DYNAMIC PERFORMANCE (Note 4)						
Turn-On Time	t _{ON}	V _{TDP} or V _{TDM} = 1.5V, R _L = 300Ω, C _L = 35pF, V _{IH} = V _{CC} , V _{IL} = 0V, Figure 1		300	800	μs

USB Host Charger Identification/Adapter Emulator

ELECTRICAL CHARACTERISTICS (continued)

($V_{CC} = 3.0V$ to $5.5V$, $T_A = T_{MIN}$ to T_{MAX} , unless otherwise noted. Typical values are at $V_{CC} = 5.0V$, $T_A = +25^{\circ}C$.) (Note 2)

PARAMETER	SYMBOL	CONDITIONS	MIN	TYP	MAX	UNITS
Turn-Off Time	t_{OFF}	V_{TDP} or $V_{TDM} = 1.5V$, $R_L = 300\Omega$, $C_L = 35pF$, $V_{IH} = V_{CC}$, $V_{IL} = 0V$, Figure 1 (Note 5)		1	5	μs
TDP, TDM Switch Propagation Delay	t_{PLH} , t_{PHL}	$R_L = R_S = 50\Omega$		60		ps
Output Skew	t_{SK}	Skew between DP and DM when connected to TDP and TDM, $R_L = R_S = 50\Omega$, Figure 2		40		ps
TDP, TDM Off-Capacitance	C_{OFF}	$f = 1MHz$, $V_{BIAS} = 0V$, $V_{IN} = 500mV_{P-P}$		2.0		pF
DP, DM On-Capacitance (Connected to TDP, TDM)	C_{ON}	$f = 240MHz$, $V_{BIAS} = 0V$, $V_{IN} = 500mV_{P-P}$		4.0	5.5	pF
-3dB Bandwidth	BW	$R_L = R_S = 50\Omega$		1000		MHz
Off-Isolation	V_{ISO}	V_{TDP} or $V_{DP} = 0dBm$, $R_L = R_S = 50\Omega$, $f = 250MHz$, Figure 3		-20		dB
Crosstalk	V_{CT}	V_{TDP} or $V_{DP} = 0dBm$, $R_L = R_S = 50\Omega$, $f = 250MHz$, Figure 3		-25		dB
DPC INTERNAL RESISTORS 1A						
DP/DM Short Pulldown	R_{PD}		320	500	730	$k\Omega$
RP1/RP2 Ratio	R_{TRP}		1.4	1.5	1.55	Ratio
RP1 + RP2 Resistance	R_{RP}		85	125.0	170	$k\Omega$
RM1/RM2 Ratio	R_{TRM}		0.85	0.86	0.87	Ratio
RM1 + RM2 Resistance	R_{RM}		60	93	125	$k\Omega$
DPC INTERNAL RESISTORS 2A						
DP/DM Short Pulldown	R_{PD}		320	500	730	$k\Omega$
RP1/RP2 Ratio	R_{TRP}		0.85	0.86	0.87	Ratio
RP1 + RP2 Resistance	R_{RP}		60	93	125	$k\Omega$
RM1/RM2 Ratio	R_{TRM}		1.4	1.5	1.55	Ratio
RM1 + RM2 Resistance	R_{RM}		85	125.0	170	$k\Omega$
DPC COMPARATORS (Note 4)						
DM1 Comparator Threshold	V_{DM1F}	DM falling	40	41	42	$\%V_{CC}$
DM1 Comparator Hysteresis				1		%
DM2 Comparator Threshold	V_{DM2F}	DM falling	6.31	7	7.6	$\%V_{CC}$
DM2 Comparator Hysteresis				1		%
DP Comparator Threshold	V_{DPR}	DP rising	45	46	47	$\%V_{CC}$
DP Comparator Hysteresis				1		%
CDP HIGH-SPEED COMPARATORS						
Threshold Voltage	V_{HSR}		120	150	205	mV
Threshold Hysteresis				10		mV

USB Host Charger Identification/Adapter Emulator

ELECTRICAL CHARACTERISTICS (continued)

($V_{CC} = 3.0V$ to $5.5V$, $T_A = T_{MIN}$ to T_{MAX} , unless otherwise noted. Typical values are at $V_{CC} = 5.0V$, $T_A = +25^\circ C$.) (Note 2)

PARAMETER	SYMBOL	CONDITIONS	MIN	TYP	MAX	UNITS
CDP INTERNAL RESISTORS						
DP Pulldown Resistor	R_{DP_DWN}			14.25	24.8	$k\Omega$
DM Pulldown Resistor	R_{DM_DWN}			14.25	24.8	$k\Omega$
CDP LOW-SPEED COMPARATORS						
V_{DM_SRC} Voltage	V_{DM_SRC}	$I_{LOAD} = 0$ to $200\mu A$	0.5		0.7	V
V_{DAT_REF} Voltage	V_{DAT_REF}		0.25		0.4	V
V_{LGC} Voltage	V_{LGC}		0.8		2.0	V
I_{DP_SINK} Current	I_{DP_SINK}	$V_{DP} = 0.15V$ to $3.6V$	50		150	μA
LOGIC INPUTS (CB0, CB1, CB2)						
CB0/CB1/CB2 Input Logic-High	V_{IH}		1.4			V
CB0/CB1/CB2 Input Logic-Low	V_{IL}				0.4	V
CB0/CB1/CB2 Input Leakage Current	I_{IN}	$V_{CC} = 5.5V$, $0V \leq V_{IN} \leq V_{IL}$ or $V_{IH} \leq V_{IN} \leq V_{CC}$	-1		+1	μA
ESD PROTECTION						
ESD Protection Level	V_{ESD}	HBM		± 2		kV

Note 2: All units are 100% production tested at $T_A = +25^\circ C$. Specifications over temperature are guaranteed by design.

Note 3: The device is operational from 3.0V to 5.5V. However, to have the valid Apple resistor-divider network, the V_{CC} supply must stay within 4.75V to 5.25V.

Note 4: Guaranteed by design.

Note 5: Does not include delay by state machine.

Test Circuits/Timing Diagrams

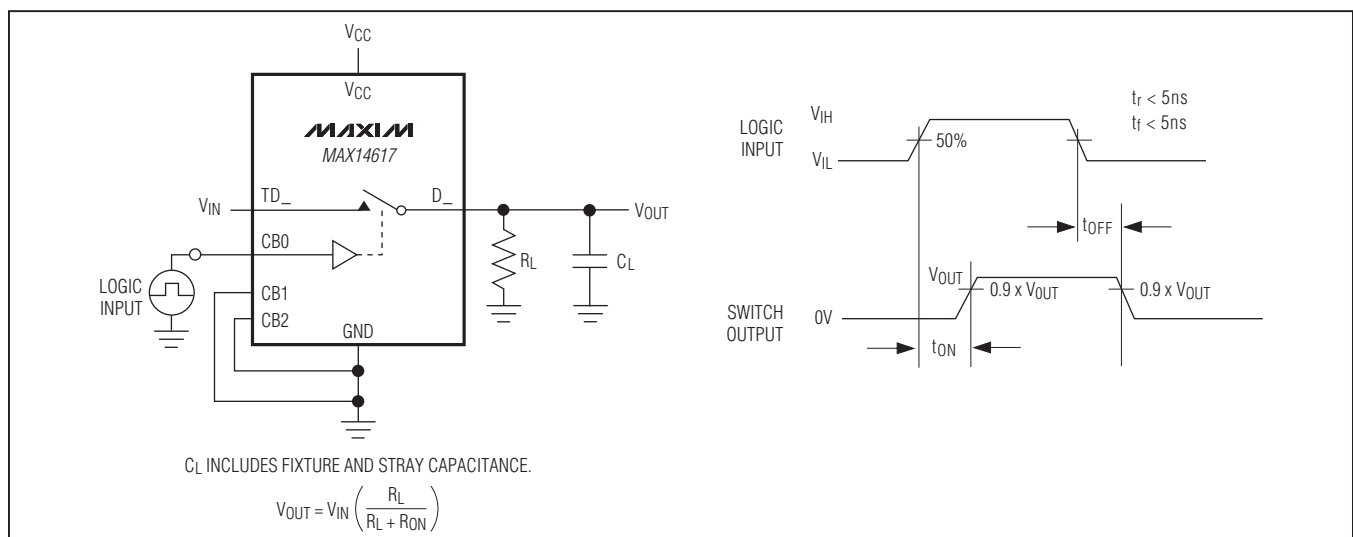

Figure 1. Switching Time

USB Host Charger Identification/Adapter Emulator

Test Circuits/Timing Diagrams (continued)

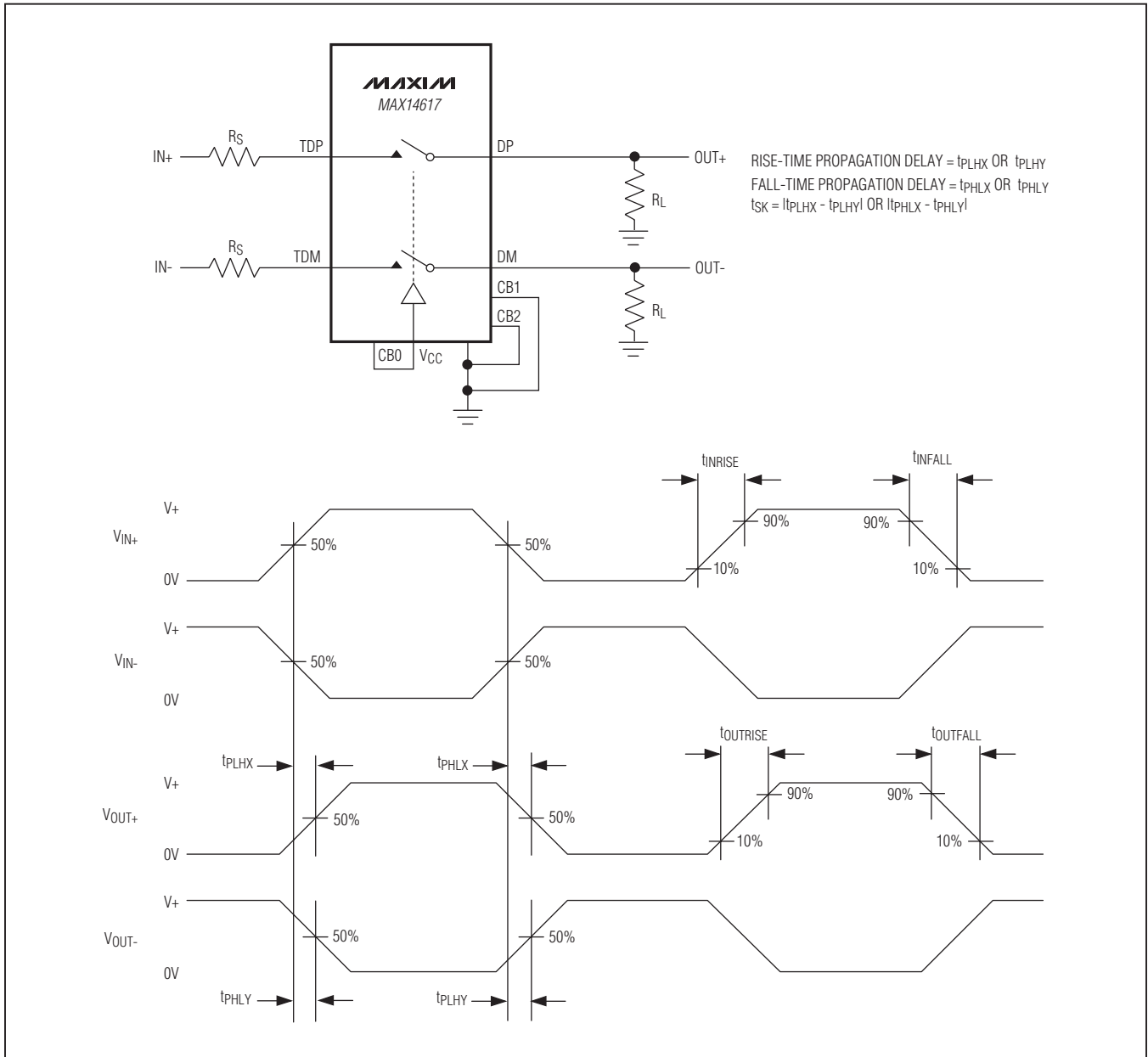

Figure 2. Output Signal Skew

USB Host Charger Identification/Adapter Emulator

Test Circuits/Timing Diagrams (continued)

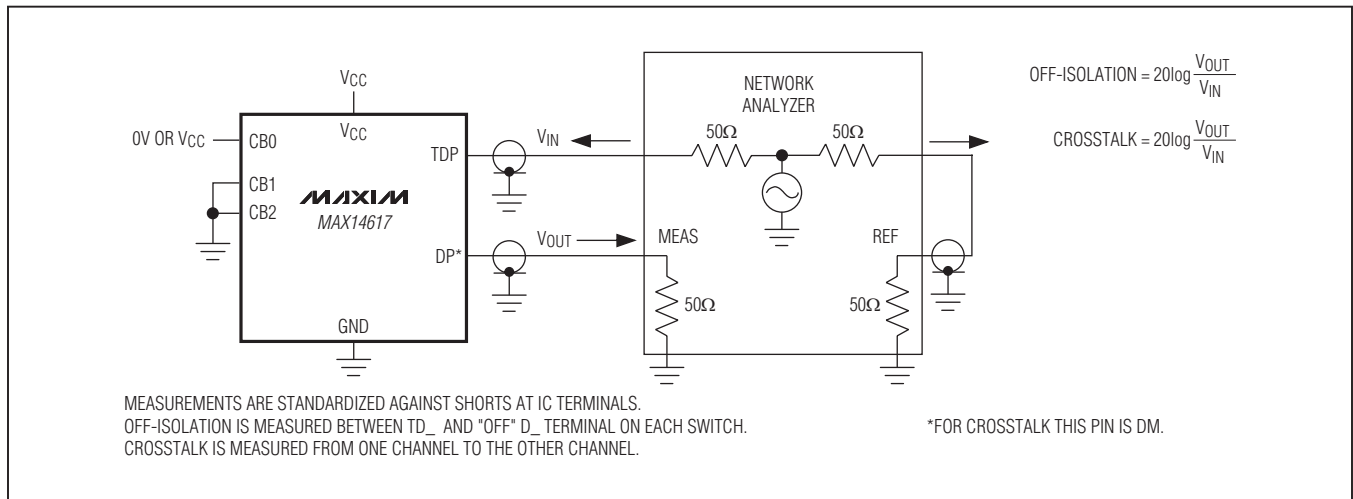

Figure 3. Off-Isolation and Crosstalk

USB Host Charger Identification/Adapter Emulator

Typical Operating Characteristics

($T_A = +25^\circ\text{C}$, unless otherwise noted.)

TDP/TDM ON-RESISTANCE vs. SUPPLY VOLTAGE

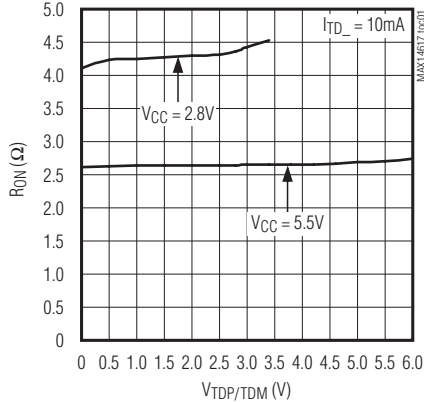

ON-RESISTANCE vs. VTDP/TDM

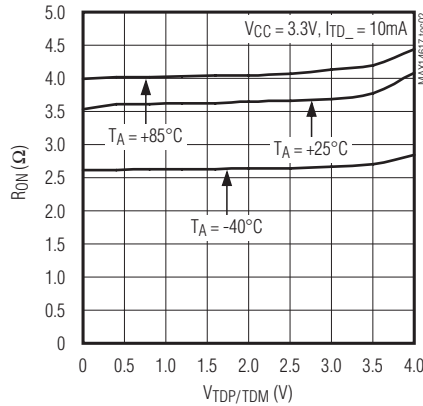

DP/DM SHORT ON-RESISTANCE vs. VDP

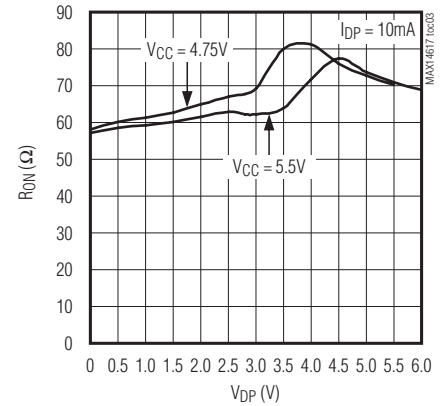

DP/DM SHORT ON-RESISTANCE vs. TEMPERATURE

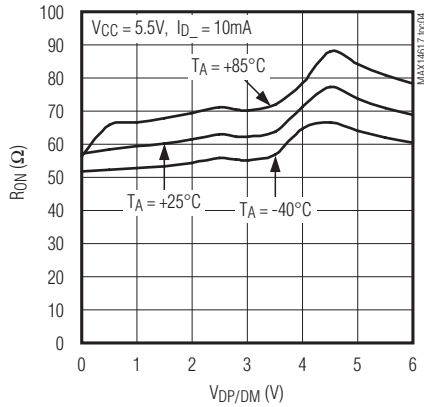

TDP/DP LEAKAGE CURRENT vs. TEMPERATURE

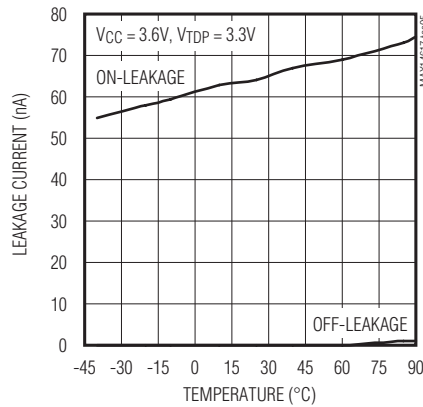

SUPPLY CURRENT vs. SUPPLY VOLTAGE

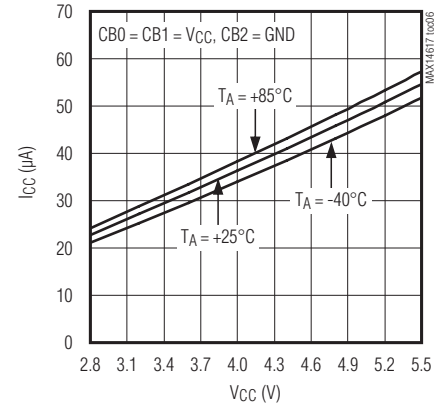

SUPPLY CURRENT vs. LOGIC LEVEL

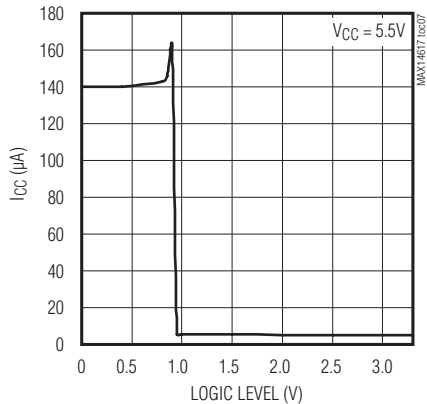

TURN-ON/TURN-OFF TIME vs. SUPPLY VOLTAGE

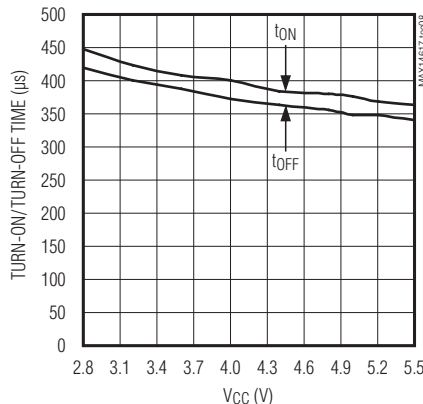

LOGIC-INPUT THRESHOLD vs. SUPPLY VOLTAGE

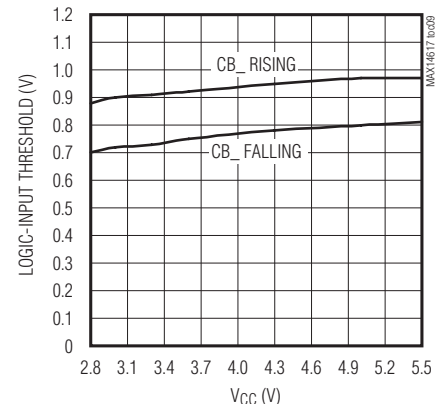

USB Host Charger Identification/Adapter Emulator

Typical Operating Characteristics (continued)

($T_A = +25^\circ\text{C}$, unless otherwise noted.)

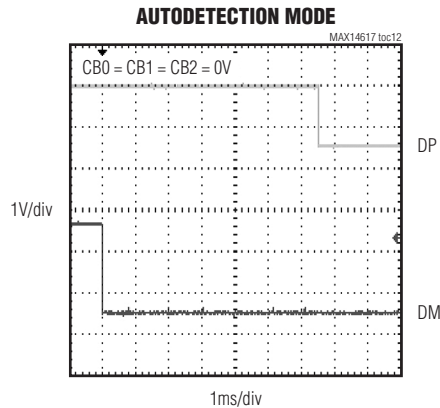
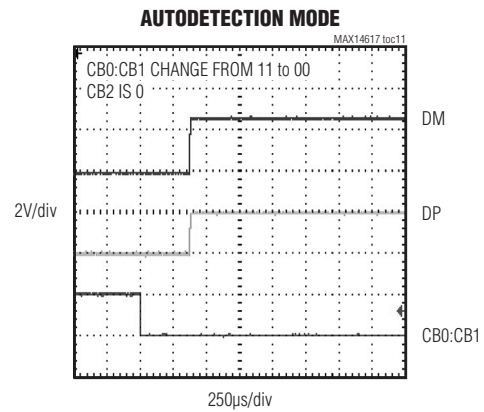
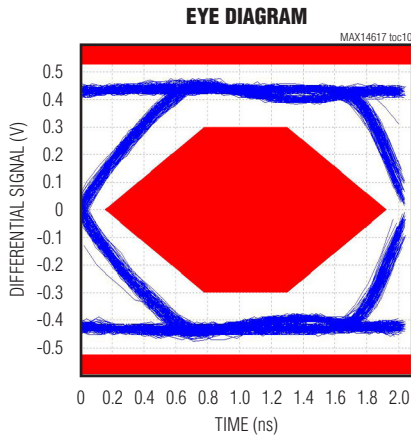

MAX14617

USB Host Charger Identification/Adapter Emulator

Pin Configuration

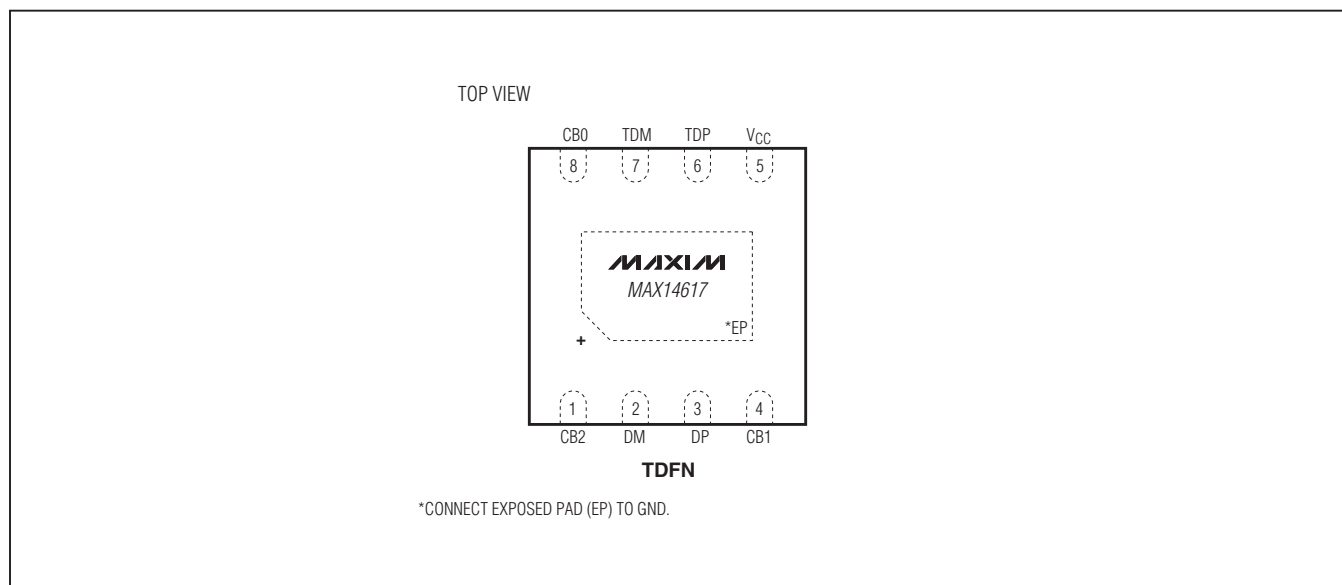

Pin Description

PIN	NAME	FUNCTION
1	CB2	Switch Control Bit. See Table 1.
2	DM	USB Connector D- Connection
3	DP	USB Connector D+ Connection
4	CB1	Switch Control Bit. See Table 1.
5	V _{CC}	Power Supply. Connect a 0.1 μ F capacitor between V _{CC} and ground as close as possible to the device.
6	TDP	Host USB Transceiver D+ Connection
7	TDM	Host USB Transceiver D- Connection
8	CB0	Switch Control Bit. See Table 1.
—	EP	Exposed Pad. Connect EP to ground. For enhanced thermal dissipation, connect EP to a copper area as large as possible.

USB Host Charger Identification/Adapter Emulator

Detailed Description

The MAX14617 adapter emulator has Hi-Speed USB analog switches that support USB hosts to identify the USB port as a charger port when the USB host is in a low-power mode and cannot enumerate USB devices. These Hi-Speed USB switches feature low 4pF (typ) on-capacitance and low 4Ω (typ) on-resistance. DP and DM can handle signals between 0V and 6V with any supply voltage.

Resistor-Dividers

The MAX14617 features an internal resistor-divider for biasing data lines to provide support for Apple-compliant devices. When the MAX14617 is not operated with the resistor-divider, the device disconnects the resistor-dividers from the supply voltage to minimize supply current requirements. The resistor-dividers are not connected in pass-through mode.

Switch Control

The MAX14617 features three digital inputs for mode selection: CB0, CB1, and CB2. Connect CB0, CB1, and CB2 to a logic-level low voltage for autodetection charger mode (AM). Change only CB1 to a logic-level high for forced dedicated charger mode (FM-S). Change

only CB0 to a logic-level low for normal high-speed pass-through mode (PM). Connect only CB2 to a logic-level low for high-speed pass-through mode with CDP emulation (CM). Connect CB2 to a logic-level high for forced Apple 2A charger mode. See [Table 1](#).

Autodetection

The MAX14617 features autodetection charger mode for dedicated chargers and USB masters. Switch control pins CB0, CB1, and CB2 must be set low to activate autodetection charger mode.

In autodetection charger mode, the device monitors the voltages at DM and DP to determine the type of device attached. If the voltage at DM is 2.05V (typ) or higher and the voltage at DP is 2.3V (typ) or lower, the voltage stays unchanged. If the voltage at DM is forced below the 2.05V (typ) threshold, the internal switch disconnects DM and DP from the resistor-divider and DP and DM are shorted together for dedicated charging mode. Also, if the voltage at DP is forced higher than the 2.3V (typ) threshold, the internal switch disconnects DM and DP from the resistor-divider and DP and DM are shorted together for dedicated charging mode.

Once the charging voltage is removed, the short between DP and DM is disconnected for normal operation.

Table 1. Digital Input State

CB0	CB1	CB2	CHARGER/USB	MODE	STATUS
X	X	1	Charger	FM-A	Force Apple 2A Charger Mode: Apple 2A resistor-dividers
0	0	0	Charger	AM	Autodetection Charger Mode
0	1	0	Charger	FM-S	Force Dedicated Charger Mode: DP/DM
1	0	0	USB	PM	USB Pass-Through Mode. Connect DP/DM to TDP/TDM.
1	1	0	USB	CM	USB Pass-Through Mode with CDP Emulation. Auto connect DP/DM to TDP/TDM depending on CDP status.

USB Host Charger Identification/Adapter Emulator

Table 2. Different Power States

STATE	DESCRIPTION
S0	System on.
S1	Power to the CPU(s) and RAM is maintained; devices that do not indicate they must remain on can be powered down.
S2	CPU is powered off.
S3	Standby (suspend to RAM). System memory context is maintained, and all other system context is lost.
S4	Hibernate. Platform context is maintained.
S5	Soft off.

USB Pass-Through Mode with CDP Emulation

The MAX14617 features a pass-through mode with CDP emulation. This is to support the higher charging current capability during the pass-through mode in normal USB operation (S0 state). The peripheral device equipped with CDP detection capability could draw a charging current as defined in USB Battery Charger Specification 1.2 when the charging host supports the CDP mode. This is a useful feature since most host USB transceivers do not have the CDP function. [Table 2](#) shows the different power states of S0–S5.

Data Contact Detect

The MAX14617 supports USB devices that require detecting the USB data lines prior to charging. When a USB Revision 1.2-compliant device is attached, the USB data lines DP and DM are shorted together. The short remains until it is detected by the USB device. This feature guarantees appropriate charger detection if a USB Revision 1.2-compliant device is attached. The autodetection charger mode is activated after the data contact detect is established. CB0, CB1, and CB2 must be set low to activate data contact detect support.

ESD Test Conditions

ESD performance depends on a variety of conditions. Contact Maxim for a reliability report that documents test methodology and results.

Ordering Information

PART	TEMP RANGE	PACKAGE TYPE
MAX14617ETA+T	-40°C to +85°C	8 TDFN-EP*

+Denotes a lead(Pb)-free/RoHS-compliant package.

T = Tape and reel.

*EP = Exposed pad.

Chip Information

PROCESS: BiCMOS

Package Information

For the latest package outline information and land patterns (footprints), go to www.maxim-ic.com/packages. Note that a "+", "#", or "-" in the package code indicates RoHS status only. Package drawings may show a different suffix character, but the drawing pertains to the package regardless of RoHS status.

PACKAGE TYPE	PACKAGE CODE	OUTLINE NO.	LAND PATTERN NO.
8 TDFN-EP	T822+2	21-0168	90-0065

USB Host Charger Identification/Adapter Emulator

Revision History

REVISION NUMBER	REVISION DATE	DESCRIPTION	PAGES CHANGED
0	10/11	Initial release	—
1	2/12	Deleted Note 6	4

Maxim cannot assume responsibility for use of any circuitry other than circuitry entirely embodied in a Maxim product. No circuit patent licenses are implied. Maxim reserves the right to change the circuitry and specifications without notice at any time. The parametric values (min and max limits) shown in the Electrical Characteristics table are guaranteed. Other parametric values quoted in this data sheet are provided for guidance.

Maxim Integrated Products, 120 San Gabriel Drive, Sunnyvale, CA 94086 408-737-7600 _____ 13

Компания «Life Electronics» занимается поставками электронных компонентов импортного и отечественного производства от производителей и со складов крупных дистрибьюторов Европы, Америки и Азии.

С конца 2013 года компания активно расширяет линейку поставок компонентов по направлению коаксиальный кабель, кварцевые генераторы и конденсаторы (керамические, пленочные, электролитические), за счёт заключения дистрибьюторских договоров

Мы предлагаем:

- Конкурентоспособные цены и скидки постоянным клиентам.
- Специальные условия для постоянных клиентов.
- Подбор аналогов.
- Поставку компонентов в любых объемах, удовлетворяющих вашим потребностям.
- Приемлемые сроки поставки, возможна ускоренная поставка.
- Доставку товара в любую точку России и стран СНГ.
- Комплексную поставку.
- Работу по проектам и поставку образцов.
- Формирование склада под заказчика.
- Сертификаты соответствия на поставляемую продукцию (по желанию клиента).
- Тестирование поставляемой продукции.
- Поставку компонентов, требующих военную и космическую приемку.
- Входной контроль качества.
- Наличие сертификата ISO.

В составе нашей компании организован Конструкторский отдел, призванный помогать разработчикам, и инженерам.

Конструкторский отдел помогает осуществить:

- Регистрацию проекта у производителя компонентов.
- Техническую поддержку проекта.
- Защиту от снятия компонента с производства.
- Оценку стоимости проекта по компонентам.
- Изготовление тестовой платы монтаж и пусконаладочные работы.



Тел: +7 (812) 336 43 04 (многоканальный)

Email: org@lifeelectronics.ru