

# PTN3356R1

ROM-based low-power DisplayPort to VGA adapter

Rev. 2.2 — 16 August 2016

Product data sheet

## 1. General description

---

PTN3356R1 is a ROM-based DisplayPort to VGA adapter optimized primarily for motherboard applications, to convert a DisplayPort signal from the chip set to an analog video signal that directly connects to the VGA connector. PTN3356R1 integrates a DisplayPort receiver, a high-speed triple video digital-to-analog converter that supports a wide range of display resolutions, for example, VGA to WUXGA (see [Table 8](#)).

PTN3356R1 supports two DisplayPort lanes operating at either 2.7 Gbit/s or 1.62 Gbit/s per lane.

PTN3356R1 supports I<sup>2</sup>C-bus over AUX per *DisplayPort standard* ([Ref. 1](#)), and bridges the VESA DDC channel to the DisplayPort Interface.

PTN3356R1 is powered from a 3.3 V power supply and consumes approximately 200 mW of power for video streaming in WUXGA resolution and 410  $\mu$ W of power in Low-power mode. The VGA output is powered down when there is no valid DisplayPort source data being transmitted. PTN3356R1 also aids in monitor detection by performing load sensing on RGB lines and reporting sink connection status to the source.

## 2. Features and benefits

---

### 2.1 VESA-compliant DisplayPort converter

- Main Link: 1-lane and 2-lane modes supported
  - ◆ HBR (High Bit Rate) at 2.7 Gbit/s per lane
  - ◆ RBR (Reduced Bit Rate) at 1.62 Gbit/s per lane
  - ◆ BER (Bit Error Rate) better than  $10^{-9}$
  - ◆ DisplayPort Link down-spreading supported
- 1 MHz AUX channel
  - ◆ Supports native AUX CH syntax
  - ◆ Supports I<sup>2</sup>C-bus over AUX CH syntax
- Active HIGH Hot Plug Detect (HPD) signal to the source

### 2.2 VESA-compliant eDP extensions

- Supports Alternate Scrambler Seed Reset (ASSR)
- Supports Alternate Enhanced Framing mode - Enhanced Framing

### 2.3 DDC channel output

- I<sup>2</sup>C-Over-AUX feature facilitates support of MCCS, DDC/CI, and DDC protocols (see [Ref. 2](#))



## 2.4 Analog video output

- VSIS 1.2 compliance ([Ref. 3](#)) for supported video output modes
- Analog RGB current-source outputs
- 3.3 V VSYNC and HSYNC outputs
- Pixel clock up to 240 MHz
- Triple 8-bit Digital-to-Analog Converter (DAC)
- Direct drive of double terminated 75  $\Omega$  load with standard 700 mV (peak-to-peak) signals

## 2.5 General features

- Monitor presence detection through load detection scheme. Connection/disconnection reported via HPD IRQ and DPCD update.
- Wide set of display resolutions are supported<sup>1</sup>:
  - ◆ 1920 × 1440, 60 Hz, 18 bpp, 234 MHz pixel clock rate
  - ◆ 2048 × 1152, 60 Hz (reduced blanking), 24 bpp, 162 MHz pixel clock rate
  - ◆ 2048 × 1536, 50 Hz (reduced blanking), 24 bpp, 167.2 MHz pixel clock rate
  - ◆ WUXGA: 1920 × 1200, 60 Hz, 18 bpp, 193 MHz pixel clock rate
  - ◆ WUXGA: 1920 × 1200, 60 Hz (reduced blanking), 24 bpp, 154 MHz pixel clock rate
  - ◆ UXGA: 1600 × 1200, 60 Hz, 162 MHz pixel clock rate
  - ◆ SXGA: 1280 × 1024, 60 Hz, 108 MHz pixel clock rate
  - ◆ XGA: 1024 × 768, 60 Hz, 65 MHz pixel clock rate
  - ◆ SVGA: 800 × 600, 60 Hz, 40 MHz pixel clock rate
  - ◆ VGA: 640 × 480, 60 Hz, 25 MHz pixel clock rate
  - ◆ Any resolution and refresh rates are supported from 25 MHz up to 180 MHz pixel clock rate at 24 bpp, or up to 240 MHz pixel clock rate at 18 bpp
- Bits per color (bpc) supported<sup>1</sup>
  - ◆ 6, 8 bits supported
  - ◆ 10, 12, 16 bits supported by truncation to 8 MSBs
- All VGA colorimetry formats (RGB) supported
- Power modes (when the application design is as per [Figure 4](#))
  - ◆ Active-mode power consumption: ~200 mW at WUXGA, 1920 × 1200, 60 Hz (18 bpc)
  - ◆ 410  $\mu$ W at Low-power mode
- Supports flexible choice of timing reference
  - ◆ On-board oscillator with external crystal, ceramic resonator
  - ◆ Different frequencies supported: 24 MHz, 25 MHz, 27 MHz
- ESD protection: 7 kV HBM
- Single power supply (3.3 V) for easy integration in the platforms
- Commercial temperature range: 0 °C to 85 °C
- 32-pin HVQFN, 5 mm × 5 mm × 0.85 mm (nominal); 0.5 mm pitch; lead-free package

1. Except for color depth beyond 8 bits, display resolutions and refresh rates are only limited to those which a standard 2-lane DisplayPort configuration is able to support over 2.7 Gbit/s per lane of DP Main Link.

### 3. Applications

- Notebook computers, tablets and desktop PCs
- Dongles, adapters, docking stations

### 4. Ordering information

Table 1. Ordering information

Type number	Topside mark	Package		
		Name	Description	Version
PTN3356R1BS	356R1	HVQFN32	plastic thermal enhanced very thin quad flat package; no leads; 32 terminals; 5 × 5 × 0.85 mm <sup>[1]</sup>	SOT617-3

[1] Maximum height is 1 mm.

#### 4.1 Ordering options

Table 2. Ordering options

Type number	Orderable part number	Package	Packing method	Minimum order quantity	Temperature
PTN3356R1BS	PTN3356R1BSMP	HVQFN32	Reel 13" Q2/T3 *standard mark SMD dry pack	6000	T <sub>amb</sub> = 0 °C to +85 °C

## 5. Functional diagram

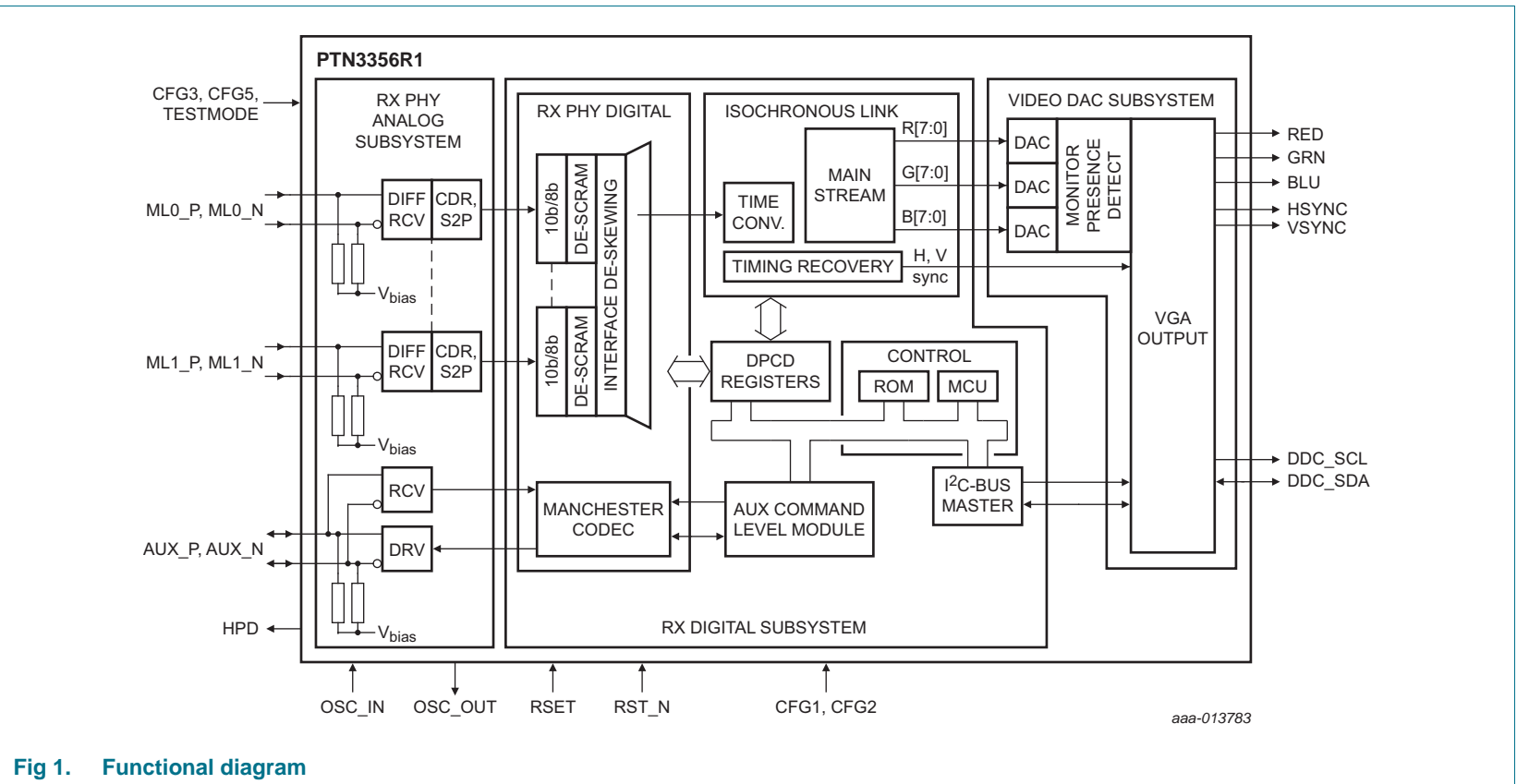
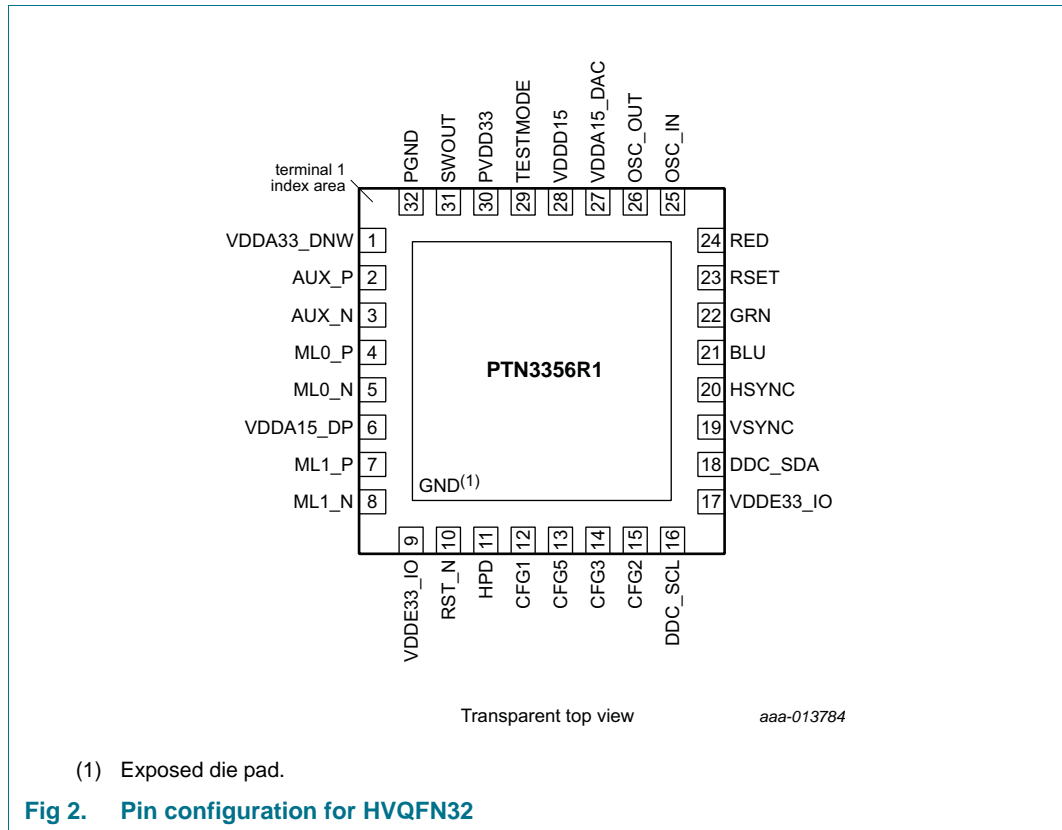

Fig 1. Functional diagram

## 6. Pinning information

### 6.1 Pinning



### 6.2 Pin description

**Table 3. Pin description**

Symbol	Pin	Type	Description
VDDA33_DNW	1	power	3.3 V power supply
AUX_P	2	self-biasing differential input	DisplayPort AUX channel positive input
AUX_N	3	self-biasing differential input	DisplayPort AUX channel negative input
ML0_P	4	self-biasing differential input	DisplayPort Main Link lane 0 positive input
ML0_N	5	self-biasing differential input	DisplayPort Main Link lane 0 negative input
VDDA15_DP	6	power	1.5 V power supply for DisplayPort PHY; power provided to this pin from SWOUT pin
ML1_P	7	self-biasing differential input	DisplayPort Main Link lane 1 positive input
ML1_N	8	self-biasing differential input	DisplayPort Main Link lane 1 negative input

Table 3. Pin description ...continued

Symbol	Pin	Type	Description
VDDE33_IO	9	power	3.3 V power supply for I/O
RST_N	10	3.3 V digital input	Reset input active LOW; pulled up to $V_{DD(3V3)}$ internally
HPD	11	3.3 V digital I/O	DisplayPort Hot Plug Detection output
CFG1	12	5 V open-drain I/O	General purpose configuration pin CFG1
CFG5	13	3.3 V digital I/O	Configuration pin supporting trinary input
CFG3	14	3.3 V digital I/O	Reserved
CFG2	15	5 V open-drain I/O	General purpose configuration pin CFG2
DDC_SCL	16	5 V open-drain I/O	DDC I <sup>2</sup> C-bus clock
VDDE33_IO	17	power	3.3 V power supply for I/O
DDC_SDA	18	5 V open-drain I/O	DDC I <sup>2</sup> C-bus data
VSYNC	19	3.3 V 50 $\Omega$ digital I/O	Vertical sync
HSYNC	20	3.3 V 50 $\Omega$ digital I/O	Horizontal sync
BLU	21	analog output	Blue DAC analog output
GRN	22	analog output	Green DAC analog output
RSET	23	input	Resistor for DAC output reference control
RED	24	analog output	Red DAC analog output
OSC_IN	25	input	Crystal oscillator input
OSC_OUT	26	output	Crystal oscillator output
VDDA15_DAC	27	power	1.5 V power supply for DAC; power provided to this pin from SWOUT pin
VDDD15	28	power	1.5 V power supply for digital core; power provided to this pin from SWOUT pin
TESTMODE	29	input	Test mode selection for CFG/JTAG
PVDD33	30	power	3.3 V power supply for switching regulator
SWOUT	31	power	Switching regulator output
PGND	32	ground	Ground for switching regulator
GND <sup>[1]</sup>	-	power	central supply ground connection (exposed die pad)

- [1] HVQFN32 package die supply ground is connected to exposed center pad. Exposed center pad must be connected to supply ground for proper device operation. For enhanced thermal, electrical, and board level performance, the exposed pad must be soldered to the board using a corresponding thermal pad on the board and for proper heat conduction through the board, thermal vias must be incorporated in the PCB in the thermal pad region.

## 7. Functional description

Referring to [Figure 1 “Functional diagram”](#), the PTN3356R1 performs protocol conversion from VESA DisplayPort specification to VESA VGA output. At the physical layer, PTN3356R1 implements the advanced DisplayPort Front-end technology (Auto receive equalization, Clock Data Recovery) to support the objectives of delivering excellent Signal Integrity (SI) performance, and consuming very low power consumption. The PTN3356R1 integrates a DisplayPort receiver (according to *VESA DisplayPort standard*, [Ref. 1](#)) and a high-speed triple 8-bit video digital-to-analog converter that supports a wide range of video resolutions (see [Table 8 “Display resolution and pixel clock rate<sup>\[1\]”</sup>](#)), up to a pixel clock rate of 240 MHz. The PTN3356R1 supports one or two DisplayPort Main Link lanes operating at either in 2.7 Gbit/s or 1.62 Gbit/s per lane.

PTN3356R1 comprises the following functional blocks:

- DP Main Link
- DP AUX CH (Auxiliary Channel)
- DPCD (DisplayPort Configuration Data)
- VGA monitor detection
- Video DAC

The RGB video data with corresponding synchronization references are extracted from the main stream video data. Main stream video attribute information is also extracted. This information is inserted once per video frame during the vertical blanking period by the DP source. The attributes describe the main video stream format in terms of geometry, timing, and color format. The original video clock and video stream are derived from these main link data.

The PTN3356R1 internal DPCD registers can be accessed by the DP source via the DP AUX channel. The monitor's DDC control bus may also be controlled via the DP AUX channel. PTN3356R1 implements the standard DisplayPort I<sup>2</sup>C-over-AUX protocol conversion to provide DP source access to the VGA plug DDC-I<sup>2</sup>C interface. The PTN3356R1 passes through sink-side status change (for example, hot-plug events) to the source side, through HPD interrupts and DPCD registers.

### 7.1 DisplayPort Main Link

The DisplayPort main link consists of two AC-coupled differential pairs. The 50 Ω termination resistors are integrated inside PTN3356R1.

The PTN3356R1 supports HBR at 2.7 Gbit/s and RBR at 1.62 Gbit/s per lane.

### 7.2 DisplayPort auxiliary channel (AUX CH)

The AUX CH is a half-duplex, bidirectional channel between DisplayPort source and sink. It consists of one differential pair transporting self-clocked data at 1 Mbit/s. The PTN3356R1 integrates the AUX CH replier (or slave), and responds to transactions initiated by the DisplayPort source AUX CH requester (or master).

The AUX CH uses the Manchester-II code for the self-clocked transmission of signals; every 'zero' is represented by LOW-to-HIGH transition, and 'one' represented by HIGH-to-LOW transition, in the middle of the bit time.

### 7.3 DPCD registers

DPCD registers that are part of the VESA DisplayPort standard are described in detail in [Ref. 1](#). The following describes the specific implementation by PTN3356R1 only.

PTN3356R1 DisplayPort receiver capability and status information about the link are reported by DisplayPort Configuration Data (DPCD) registers, when a DP source issues a read command on the AUX CH. The DP source device can also write to the link configuration field of DPCD to configure and initialize the link. The DPCD is DisplayPort v1.2a compliant.

PTN3356R1 specific capabilities are made available to DP source in the relevant DPCD read/write registers. In line with the DisplayPort standard ([Ref. 1](#)), the specific Link controls are also made available to initialize and maintain the DisplayPort Link.

It is the responsibility of the DP source to issue commands only within the capability of the PTN3356R1 as defined in the 'Receiver Capability Field' in order to prevent undefined behavior. PTN3356R1 specific DPCD registers are listed in [Table 4](#).

#### 7.3.1 PTN3356R1 specific DPCD register settings

**Table 4. PTN3356R1 specific DPCD registers**

DPCD register <a href="#">[1]</a>	Description	Power-on Reset value	Read/write over AUX CH
<b>Receiver Capability Field</b>			
0000Ch	I <sup>2</sup> C-bus speed control capabilities bit map. Speed control is not supported through DPCD register. Default speed of 50 kbit/s is supported.	00h	read only
0000Dh	eDP_CONFIGURATION_CAP. Bit 0 = ALTERNATE_SCRAMBLER_RESET_CAPABLE. A setting of 1 indicates that this is an eDP device that can use the eDP alternate scrambler reset value of FFFFh. Bit 1 = FRAMING_CHANGE_CAPABLE. A setting of 1 indicates that this is an eDP device that uses only Enhanced Framing independently of the setting by the source of ENHANCED_FRAME_EN. Bit 2 = reserved for eDP. Read 0. Bit 3 = DPCD_DISPLAY_CONTROL_CAPABLE. A setting of 1 indicates that display control registers starting at address 00700h are enabled. Bits 7:4 = reserved for eDP. Read all zeros.	03h	read only
<b>Link Configuration Field</b>			
00109h	I <sup>2</sup> C-bus speed control capabilities bit map. Speed control is not supported and the default speed of 50 kbit/s is supported. Writes are ignored and reads would get zeros.	00h	read/write



Table 4. PTN3356R1 specific DPCD registers ...continued

DPCD register [1]	Description	Power-on Reset value	Read/write over AUX CH
0010Ah	<p>Bit 0 = ALTERNATE_SCRAMBLER_RESET_ENABLE. Source sets to 1 to select the alternate scrambler reset. Writes ignored if ALTERNATE_SCRAMBLER_RESET_CAPABLE = 0. Power-on default value = 0.</p> <p>Bit 1 = FRAMING_CHANGE_ENABLE. Source sets to 1 to select the framing change. Writes ignored if FRAMING_CHANGE_CAPABLE = 0. Power-on default value = 0.</p> <p>Bits 6:2 = reserved. Read all zeros.</p> <p>Bit 7 = PANEL_SELF_TEST_ENABLE (not supported in PTN3356R1).</p>	00h	read/write
<b>Branch device specific field</b>			
00500h	BRANCH_IEEE_OUI 7:0 Branch vendor 24-bit IEEE OUI. NXP OUI = 00	00h	read only
00501h	BRANCH_IEEE_OUI 15:8 NXP OUI = 60	60h	read only
00502h	BRANCH_IEEE_OUI 23:16 NXP OUI = 37	37h	read only
00503h	ID string = 3356N2	33h	read only
00504h		33h	read only
00505h		35h	read only
00506h		36h	read only
00507h		4Eh	read only
00508h		32h	read only
00509h		Hardware revision level v1.1	10h
0050Ah	Firmware/software major revision level	01h	read only
0050Bh	Firmware/software minor revision level	02h	read only
0050Ch to 005FFh	RESERVED		read only

[1] Byte fields that are not explicitly listed are by definition reserved ('RES') and their default value is 0h.

**7.4 VGA monitor detection**

The PTN3356R1 implements a robust scheme for VGA monitor detection. It senses presence or absence of VGA monitor load termination (75 Ω) by pulsing the RGB lines. The load sensing operation is performed periodically to determine the latest VGA connectivity status. If the VGA monitor is disconnected, then the detection logic informs the host platform via IRQ\_HPD signal.

**7.5 EDID handling**

Figure 3 shows a DisplayPort-to-analog video converter between the DisplayPort source and a VGA monitor. The PTN3356R1 implements a DP I<sup>2</sup>C-Over-AUX protocol, providing for DP source access to the monitor’s DDC bus. With this, the monitor’s EDID data is made available to DP source for access at any time.

It is the responsibility of the source to choose only video modes which are declared in the EDID and to adjust the DisplayPort link capabilities (link rate and lane count) to provide the necessary video bandwidth. The PTN3356R1 does not cache or modify the EDID to match the capabilities of the DisplayPort link data.

If the DisplayPort source drives display modes that are not specified in the EDID mode list, the PTN3356R1 does not detect such conditions, and it depends entirely on the VGA display on what is being displayed.

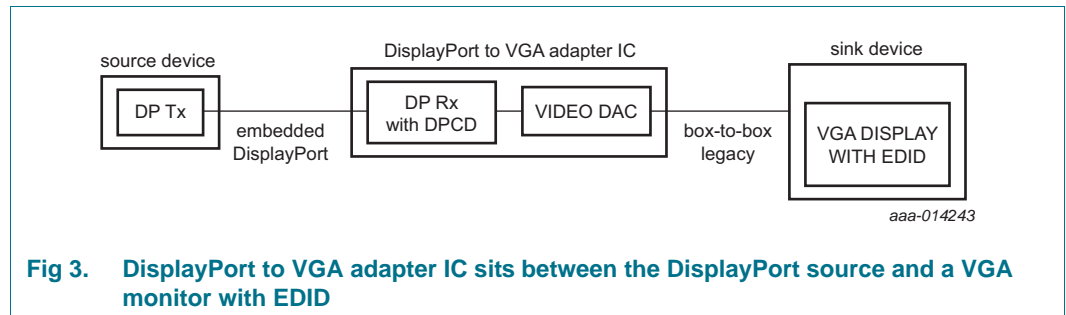

**Fig 3. DisplayPort to VGA adapter IC sits between the DisplayPort source and a VGA monitor with EDID**

**7.6 Triple 8-bit video DACs and VGA outputs**

The triple 8-bit video DACs output a 700 mV (peak-to-peak) analog video output signal into 37.5 Ω load, as is the case of a doubly terminated 75 Ω cable. The DAC is capable of supporting the maximum pixel rate supported by a two-lane DP link (240 MHz).

**7.6.1 DAC reference resistor**

An external reference resistor must be connected between pin RSET and ground. This resistor sets the reference current which determines the analog output level, and is specified as 1.2 kΩ with a 1 % tolerance. This value allows a 0.7 V (peak-to-peak) output into a 37.5 Ω load (for example, double-terminated 75 Ω coaxial cable).

## 8. Power-up and reset

PTN3356R1 has built-in power-on reset circuitry which automatically sequences the part through reset and initialization. In addition, there is a dedicated pin (RST\_N) to control/effect reset operation externally. This provides flexibility at the platform level for debug or application purpose.

Before link is established, the PTN3356R1 holds VSYNC and HSYNC signals LOW and blanks the RGB signals.

While the PTN3356R1 performs power-on initialization,

- The HPD signal is driven LOW, to indicate to the DisplayPort source that the PTN3356R1 is not ready for AUX channel communication. Once the device is initialized, the HPD level is produced based on CFG1/CFG2 setting
- The RGB outputs are disabled
- The VSYNC and HSYNC outputs are maintained LOW as long as there is no active video streaming from the DisplayPort source.

## 9. Configurability

The PTN3356R1 delivers flexibility for application usage by providing configurability via two options:

- Configuration pins CFG1, CFG2, CFG5, and TESTMODE
- DP-AUX vendor-specific configuration registers

The pins provide limited application board level configurability, whereas vendor-specific configuration registers deliver ultimate flexibility. The configuration pin changes (static, dynamic) are reflected in the IC behavior.

The configuration pin definitions are as follows:

- CFG1, CFG2 are used as dedicated configuration pins with binary leveled I/O. The use of these configuration pins is defined in [Table 7](#).
- Configuration pin CFG5 selects OSC\_IN clock frequency setting. [Table 5](#) captures the pin definition.

**Table 5. CFG5 pin definition**

Configuration input	OSC_IN clock frequency setting
HIGH	24 MHz
LOW	25 MHz
OPEN	27 MHz

The TESTMODE pin is used to indicate selection of JTAG or configuration for CFG1, CFG2 and CFG5. [Table 6](#) defines the possible combinations of TESTMODE pin.

Table 6. TESTMODE pin definition

Pin value	Mode selection
LOW	Configuration pin functionality is selected
OPEN	Configuration pin functionality is selected
HIGH	JTAG functionality is selected.

CFG1, CFG2 can be used in configuration pin mode. PTN3356R1 automatically detects the mode in which these pins are used. If they are used as Configuration pins, [Table 7](#) determines the possible and allowed combinations for these pin settings.

Table 7. CFG1/CFG2 pin definitions

Pin value	System behavior
00	Compliant HPD behavior
01	Most interoperable (non-compliant) HPD behavior
10	Most interoperable (non-compliant) HPD behavior
11	(Default) Compliant behavior

## 10. Application design-in information

With its maximum integration features, the PTN3356R1 has low BOM requirement at the platform application level. [Figure 4](#) illustrates the PTN3356R1 usage in a system application context. On the DP side, it is connected to DP source and the VGA side, it is connected to VGA connector. The PTN3356R1 system application requires the following components additionally: supply decoupling capacitors, DC blocking capacitors, pull-up/down resistors, (optional) inductor for DC-to-DC converter, crystal oscillator. For more details on reference design information, contact NXP team.

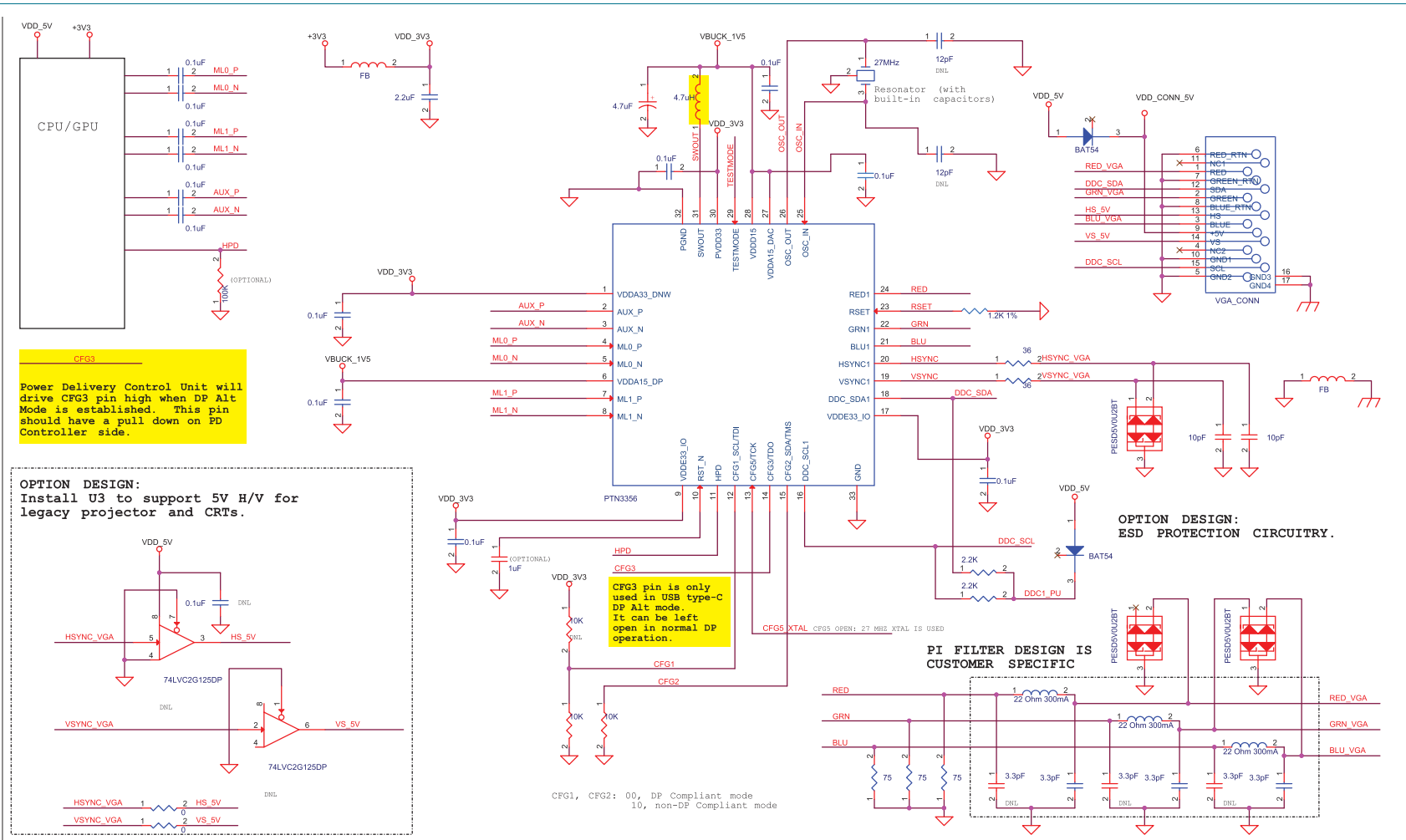

aaa-01378c

Part shaded in yellow is extra component required in DC-to-DC converter mode to achieve low power performance.

Fig 4. Application with DC-to-DC converter mode

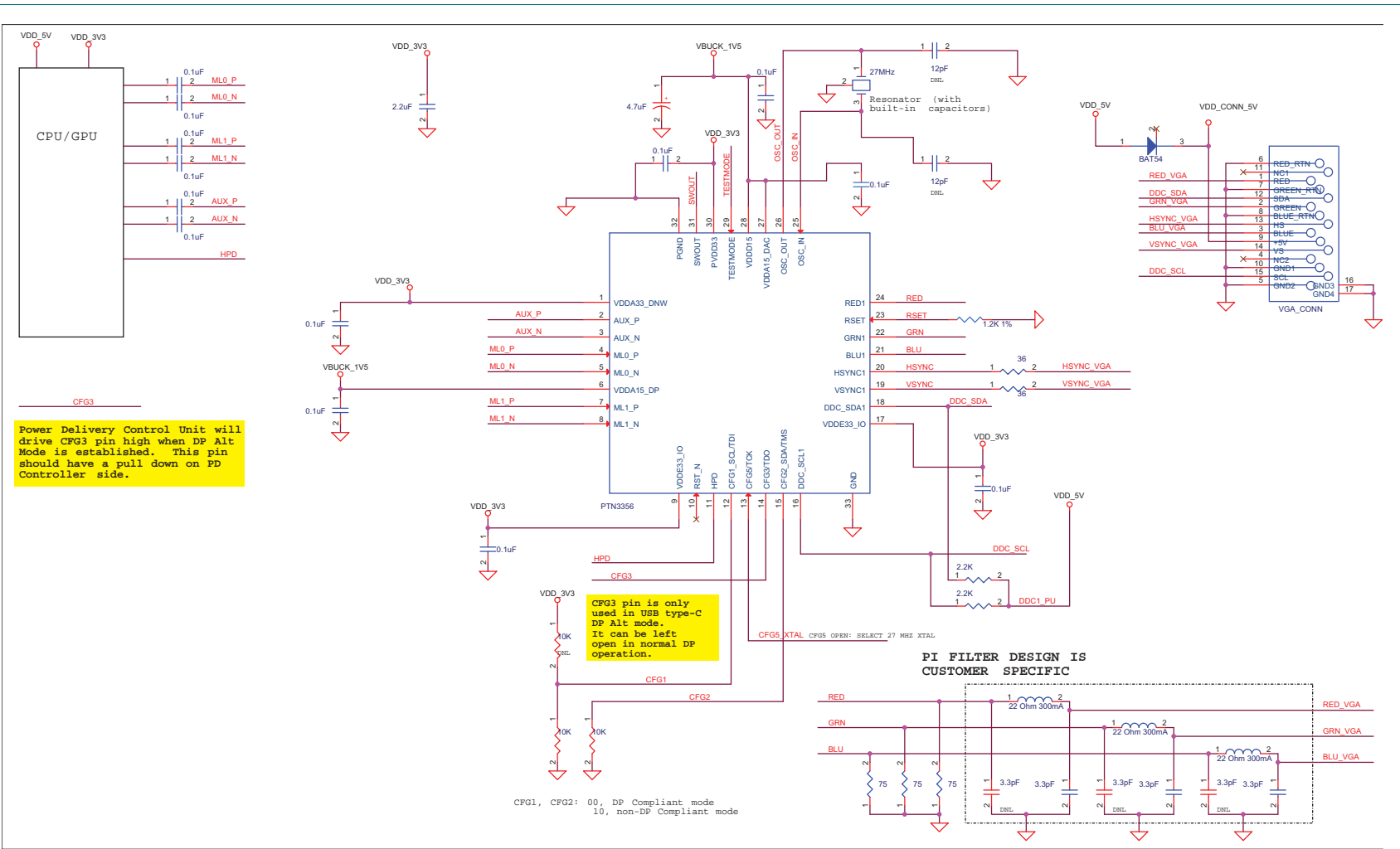

Fig 5. Application with LDO mode

## 10.1 Display resolution

[Table 8](#) lists some example display resolutions and clock rates that PTN3356R1 supports. (Refer to [Footnote 1 on page 2.](#))

**Table 8.** Display resolution and pixel clock rate<sup>[1]</sup>

Display type	Active video		Total frame		Bits per pixel	Vertical frequency (Hz)	Pixel clock (MHz)	Data rate (Gbit/s)	Standard type
	Horizontal	Vertical	Horizontal total (pixel)	Vertical total (line)					
VGA	640	480	800	525	24	59.94	25.175	0.76	Industry standard
SVGA	800	600	1056	628	24	60.317	40.000	1.20	VESA guidelines
XGA	1024	768	1344	806	24	60.004	65.000	1.95	VESA guidelines
XGA+	1152	864	1600	900	24	75	108.000	3.24	VESA standard
HD	1360	768	1792	795	24	60.015	85.500	2.56	VESA standard
HD/WXGA	1366	768	1792	798	24	59.79	85.501	2.57	VESA standard
HD/WXGA	1280	720	1650	750	24	60	74.250	2.23	CEA standard
WXGA	1280	800	1680	831	24	59.81	83.500	2.50	CVT
WXGA	1280	800	1696	838	24	74.934	106.500	3.19	CVT
WXGA	1280	800	1712	843	24	84.88	122.500	3.68	CVT
SXGA-	1280	960	1800	1000	24	60	108.000	3.24	VESA standard
SXGA	1280	1024	1688	1066	24	60.02	108.000	3.24	VESA standard
SXGA	1280	1024	1688	1066	24	75.025	135.001	4.05	VESA standard
SXGA	1280	1024	1728	1072	24	85.024	157.500	4.72	VESA standard
SXGA+	1400	1050	1864	1089	24	59.978	121.749	3.65	CVT
WXGA+	1440	900	1904	934	24	59.887	106.499	3.19	CVT
HD+	1600	900	1800	1000	24	60 (RB)	108.000	3.24	VESA standard
UXGA	1600	1200	2160	1250	24	60	162.000	4.86	VESA standard
UXGA	1600	1200	2160	1250	24	65	175.500	5.27	VESA standard
WSXGA+	1680	1050	2240	1089	24	59.954	146.249	4.39	CVT
FHD	1920	1080	2200	1125	24	60	148.500	4.46	CEA standard
WUXGA	1920	1200	2592	1245	18	59.885	193.251	4.35	CVT
WUXGA	1920	1200	2080	1235	24	59.95 (RB)	154.000	4.62	CVT RB
2.76M3	1920	1440	2600	1500	18	60	234.000	5.27	VESA standard
QWXGA	2048	1152	2250	1200	24	60 (RB)	162.000	4.86	CVT RB
QXGA	2048	1536	2128	1573	24	49.95 (RB)	167.20	5.02	CVT RB

[1] Contact NXP team for other monitor timings not listed in this table.

The available bandwidth over a 2-lane HBR DisplayPort v1.2a link limits pixel clock rate support to:

- 240 MHz at 6 bpc
- 180 MHz at 8 bpc

10.2 Power supply filter

Sufficient decoupling capacitance to ground should be connected from each  $V_{DD}$  pin directly to ground to filter supply noise.

10.3 DAC terminations

Typically, the VGA RGB outputs are (doubly) terminated. Figure 6 shows an example VGA application. A  $75\ \Omega$  termination is used to terminate inside the motherboard, and another  $75\ \Omega$  termination is typically used inside the RGB monitor. The load sensing mechanism assumes this double termination. Figure 7 is another example of VGA application with  $50\ \Omega$  PCB trace impedance with  $150\ \Omega$  terminations.

In general, it is left to the system integrator to decide on their specific implementation.

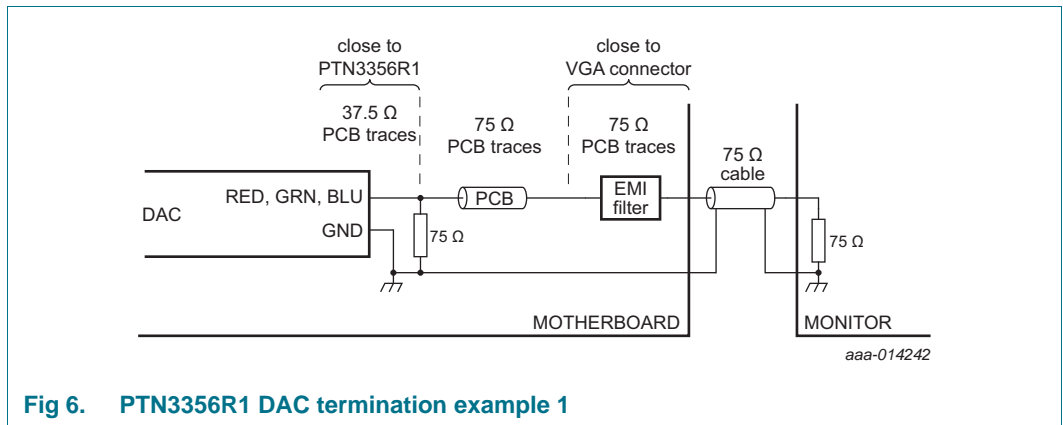

Fig 6. PTN3356R1 DAC termination example 1

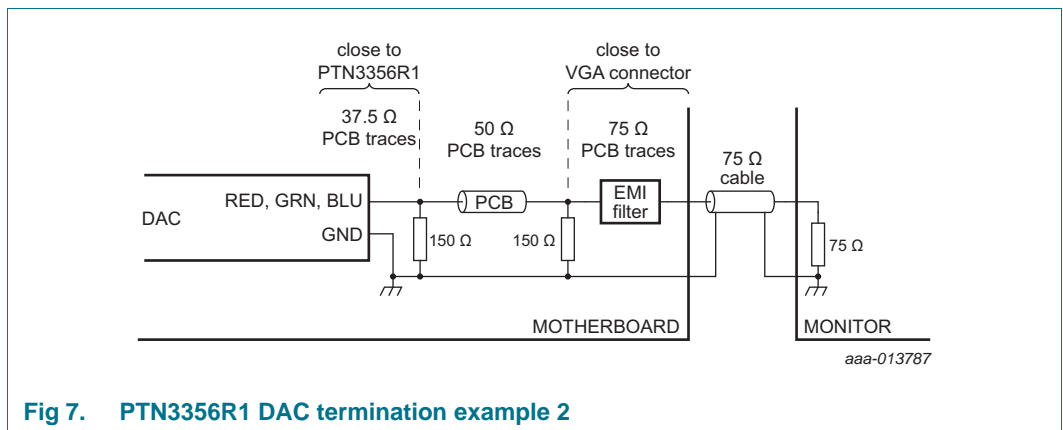

Fig 7. PTN3356R1 DAC termination example 2



## 10.4 Timing reference

PTN3356R1 requires a crystal or ceramic resonator for a stable VGA clock timing reference. Resonators have a higher frequency tolerance than crystals, but have the advantage of integrated capacitors and therefore a small PCB area and potentially lower cost.

**Table 9. Required crystal specifications (SMD components)**

Crystal parameters	Specifications
Frequency	24 MHz, 25 MHz or 27 MHz
Operation mode	Fundamental
Frequency tolerance	$\pm 1$ % maximum
Frequency stability over temperature	$\pm 0.4$ % maximum
Load capacitance ( $C_L$ )	18 pF
Shunt capacitance	$< 2$ pF
Equivalent Series Resistance (ESR)	$< 150 \Omega$

## 11. Limiting values

**Table 10. Limiting values**

In accordance with the Absolute Maximum Rating System (IEC 60134).

Symbol	Parameter	Conditions	Min	Max	Unit
$V_{DD(3V3)}$	supply voltage (3.3 V)		-0.3	+4.6	V
$V_I$	input voltage	3.3 V CMOS inputs	-0.3	$V_{DD(3V3)} + 0.5$	V
$T_{stg}$	storage temperature		-65	+150	°C
$V_{ESD}$	electrostatic discharge voltage	HBM <a href="#">[1]</a>	-	7000	V
		CDM <a href="#">[2]</a>	-	1000	V

[1] Human Body Model: ANSI/ESDA/JEDEC JDS-001-2012 (Revision of ANSI/ESDA/JEDEC JS-001-2011), ESDA/JEDEC Joint standard for ESD sensitivity testing, Human Body Model - Component level; Electrostatic Discharge Association, Rome, NY, USA; JEDEC Solid State Technology Association, Arlington, VA, USA.

[2] Charged Device Model: JESD22-C101E December 2009 (Revision of JESD22-C101D, October 2008), standard for ESD sensitivity testing, Charged Device Model - Component level; JEDEC Solid State Technology Association, Arlington, VA, USA.

## 12. Recommended operating conditions

**Table 11. Operating conditions**

Symbol	Parameter	Conditions	Min	Typ	Max	Unit
$V_{DD(3V3)}$	supply voltage (3.3 V)		2.8	3.3	3.6	V
$t_r$	rise time	supply voltage	-	-	10	ms
$V_I$	input voltage	3.3 V CMOS inputs	0	3.3	3.6	V
		SDA and SCL inputs with respect to ground	0	5	5.5	V
$R_{ext(RSET)}$	external resistance on pin RSET	between RSET (pin 21) and GND	-	$1.20 \pm 1\%$	-	k $\Omega$
$T_{amb}$	ambient temperature	commercial grade	0	-	85	°C

## 13. Characteristics

### 13.1 Current consumption, power dissipation and thermal characteristics

**Table 12. Current consumption, power dissipation and thermal characteristics**

Over operating free-air temperature range, unless otherwise noted.

Symbol	Parameter	Conditions	Min	Typ	Max	Unit
I <sub>DD</sub>	supply current	normal operation, WUXGA / 193 MHz pixel clock; V <sub>DD(3V3)</sub> = 3.3 V	-	60	-	mA
		Low power D3 mode; V <sub>DD(3V3)</sub> = 3.3 V	-	124	-	μA
P	power dissipation	normal operation, WUXGA / 193 MHz pixel clock (reduced blanking)	-	-	-	-
		Buck converter mode; PTN3356R1 being used as per <a href="#">Figure 4</a>	-	200	-	mW
		LDO mode; PTN3356R1 being used as per <a href="#">Figure 5</a>	-	405	-	mW
R <sub>th(j-a)</sub>	thermal resistance from junction to ambient	in free air for SOT617-3	-	45	-	K/W

**Table 13. Device characteristics**

Over operating free-air temperature range, unless otherwise noted.

Symbol	Parameter	Conditions	Min	Typ	Max	Unit
t <sub>startup</sub>	start-up time	device start-up time from power-on to HPD = HIGH; VGA monitor remains connected at power-on <sup>[1]</sup> ; RST_N = HIGH; supply voltage within operating range to specified operating characteristics	-	-	100	ms
t <sub>w(rst)</sub>	reset pulse width	device is supplied with valid supply voltage	10	-	-	μs
t <sub>d(rst)</sub>	reset delay time	device reset delay time from RST_N toggling (LOW to HIGH) until HPD goes HIGH; VGA monitor remains connected at power-on <sup>[1]</sup> ; supply voltage within operating range to specified operating characteristics	-	-	100	ms

[1] VGA monitor remains connected at power-on — this condition is applicable only when PTN3356R1 is used in most interoperable (non-compliant) HPD mode (that is, CFG1/CFG2 is '01' or '10').

### 13.2 DisplayPort receiver main link

**Table 14. DisplayPort receiver main link characteristics<sup>[1]</sup>**

Over operating free-air temperature range, unless otherwise noted.

Symbol	Parameter	Conditions	Min	Typ	Max	Unit
UI	unit interval	for high bit rate (2.7 Gbit/s per lane)	-	370	-	ps
		for low bit rate (1.62 Gbit/s per lane)	-	617	-	ps
$\Delta f_{\text{DOWN\_SPREAD}}$	link clock down spreading	[2]	0.0	-	0.5	%
$V_{\text{RX\_DIFFp-p}}$	differential input peak-to-peak voltage	at RX package pins				
		for high bit rate [3]	120	-	-	mV
		for reduced bit rate [3]	40	-	-	mV
$V_{\text{RX\_DC\_CM}}$	RX DC common mode voltage	[4]	0	-	2.0	V
$I_{\text{RX\_SHORT}}$	RX short-circuit current limit	[5]	-	-	50	mA
$C_{\text{RX}}$	AC coupling capacitor	on DP Main Link and AUX inputs	75	-	200	nF
$f_{\text{RX\_TRACK\_BW\_HBR}}$	jitter closed loop tracking bandwidth (High Bit Rate)	[6]	10	-	20	MHz
$f_{\text{RX\_TRACK\_BW\_RBR}}$	jitter closed loop tracking bandwidth (Reduced Bit Rate)	[6]	5.4	-	20	MHz

- [1] Ref. 1 supersedes in case of any mismatch of specification items.
- [2] Up to 0.5 % down spread is supported. Modulation frequency range of 30 kHz to 33 kHz must be supported.
- [3] Informative; refer to Figure 8 for definition of differential voltage.
- [4] Common mode voltage is equal to  $V_{\text{bias\_RX}}$  voltage.
- [5] Total drive current of the input bias circuit when it is shorted to its ground.
- [6] The measurements are always taken with PRBS7 test signal. Minimum CDR closed loop tracking bandwidth at the receiver when the input is a PRBS7 pattern.

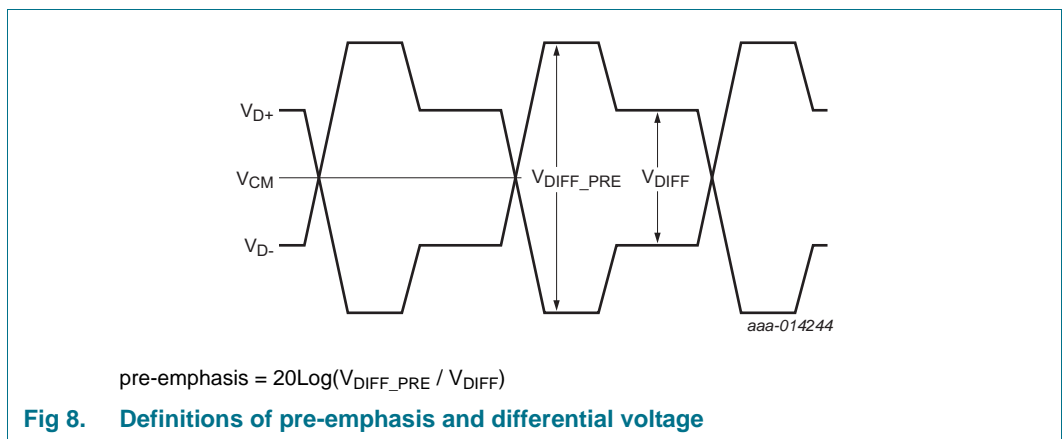

### 13.3 DisplayPort receiver AUX CH

**Table 15. DisplayPort receiver AUX CH characteristics**<sup>[1]</sup>

Over operating free-air temperature range, unless otherwise noted.

Symbol	Parameter	Conditions	Min	Typ	Max	Unit
UI	unit interval	AUX	[2] 0.4	0.5	0.6	μs
t <sub>jitter(cc)</sub>	cycle-to-cycle jitter time	transmitting device	[3] -	-	0.04	UI
		receiving device	[4] -	-	0.05	UI
V <sub>AUX_DIFFp-p</sub>	AUX differential peak-to-peak voltage	transmitting device	[5] 0.39	-	1.38	V
		receiving device	[5] 0.32	-	1.36	V
R <sub>AUX_TERM(DC)</sub>	AUX CH termination DC resistance	informative	-	100	-	Ω
V <sub>AUX_DC_CM</sub>	AUX DC common-mode voltage		[6] 0	-	2.0	V
V <sub>AUX_TURN_CM</sub>	AUX turnaround common-mode voltage		[7] -	-	0.3	V
I <sub>AUX_SHORT</sub>	AUX short-circuit current limit		[8] -	-	90	mA
C <sub>AUX</sub>	AUX AC coupling capacitor		[9] 75	-	200	nF

[1] [Ref. 1](#) supersedes in case of any mismatch of specification items.

[2] Results in the bit rate of 1 Mbit/s including the overhead of Manchester II coding.

[3] Maximum allowable UI variation within a single transaction at connector pins of a transmitting device. Equal to 24 ns maximum. The transmitting device is a source device for a request transaction and a sink device for a reply transaction.

[4] Maximum allowable UI variation within a single transaction at connector pins of a receiving device. Equal to 30 ns maximum. The transmitting device is a source device for a request transaction and a sink device for a reply transaction.

[5]  $V_{AUX\_DIFFp-p} = 2 \times |V_{AUX+} - V_{AUX-}|$ .

[6] Common-mode voltage is equal to V<sub>bias\_TX</sub> (or V<sub>bias\_RX</sub>) voltage.

[7] Steady-state common-mode voltage shift between transmit and receive modes of operation.

[8] Total drive current of the transmitter when it is shorted to its ground.

[9] The AUX CH AC coupling capacitor placed both on the DisplayPort source and sink devices.

### 13.4 HPD characteristics

**Table 16. HPD characteristics<sup>[1]</sup>**

Over operating free-air temperature range, unless otherwise noted.

Symbol	Parameter	Conditions	Min	Typ	Max	Unit
<b>Output characteristics</b>						
V <sub>OH</sub>	HIGH-level output voltage	I <sub>OH</sub> = 2 mA	2.4	-	-	V
V <sub>OL</sub>	LOW-level output voltage	I <sub>OL</sub> = -2 mA	-	-	0.4	V
I <sub>OSH</sub>	HIGH-level short-circuit output current	drive HIGH; cell connected to ground	-	-	16	mA
I <sub>OSL</sub>	LOW-level short-circuit output current	drive LOW; cell connected to V <sub>DD</sub>	-	-	15	mA

[1] [Ref. 1](#) supersedes in case of any mismatch of specification items.

### 13.5 DDC/CFG1, CFG2 characteristics

**Table 17. DDC/CFG1, CFG2 characteristics**

V<sub>CC</sub> = 4.5 V to 5.5 V<sup>[1]</sup>. Over operating free-air temperature range, unless otherwise noted.

Symbol	Parameter	Conditions	Min	Typ	Max	Unit
<b>Input characteristics</b>						
V <sub>IH</sub>	HIGH-level input voltage		0.7 × V <sub>DD(3V3)</sub>	-	5.5	V
V <sub>IL</sub>	LOW-level input voltage		-0.5	-	+0.3 × V <sub>DD(3V3)</sub>	V
V <sub>I(hys)</sub>	hysteresis of input voltage		0.1 × V <sub>DD(3V3)</sub>	-	-	V
I <sub>LI</sub>	input leakage current	V <sub>I</sub> = 5 V	-	-	10	μA
<b>Output characteristics</b>						
I <sub>OL</sub>	LOW-level output current	V <sub>OL</sub> = 0.4 V	3.0	-	-	mA
I <sub>O(sc)</sub>	short-circuit output current	drive LOW; cell connected to V <sub>DD(3V3)</sub>	-	-	40.0	mA
C <sub>io</sub>	input/output capacitance	V <sub>I</sub> = 3 V or 0 V				
		V <sub>DD(3V3)</sub> = 3.3 V	-	6	7	pF
		V <sub>DD(3V3)</sub> = 0 V	-	6	7	pF

[1] V<sub>CC</sub> is the pull-up voltage for DDC/CFG1, CFG2.

[2] [Table 17](#) applies to CFG1 and CFG2 pins as they operate as I<sup>2</sup>C-bus I/O but only used as CFG pins.

## 13.6 DAC

**Table 18. DAC characteristics**

Over operating free-air temperature range, unless otherwise noted.

Symbol	Parameter	Conditions	Min	Typ	Max	Unit
$N_{res(DAC)}$	DAC resolution		-	-	8	bit
$f_{clk}$	clock frequency		-	-	240	MHz
$\Delta I_{o(DAC)}$	DAC output current variation	DAC-to-DAC	-	-	4	%
INL	integral non-linearity		-1	$\pm 0.25$	+1	LSB
DNL	differential non-linearity		-0.5	$\pm 0.1$	+0.5	LSB
$V_{o(DAC)max}$	maximum DAC output voltage		665	700	770	mV
$C_{o(DAC)}$	DAC output capacitance		-	3.5	-	pF
	DAC noise injection ratio		-1.5	-	+1.5	%

## 13.7 HSYNC, VSYNC characteristics

**Table 19. HSYNC and VSYNC characteristics**

Over operating free-air temperature range, unless otherwise noted.

Symbol	Parameter	Conditions	Min	Typ	Max	Unit
<b>Output characteristics</b>						
$V_{OH}$	HIGH-level output voltage	$I_{OH} = 8 \text{ mA}$ ; $V_{DD(3V3)} = 3.3 \text{ V} \pm 10 \%$	2.4	-	-	V
$V_{OL}$	LOW-level output voltage	$I_{OL} = -8 \text{ mA}$	-	-	0.5	V
$I_{OSH}$	HIGH-level short-circuit output current	drive HIGH; cell connected to ground	[1]	-	100	mA
$I_{OSL}$	LOW-level short-circuit output current	drive LOW; cell connected to $V_{DD}$	[1]	-	100	mA

[1] The parameter values specified are simulated and absolute values.

## 13.8 Configuration pins CFG3, CFG5, TESTMODE

**Table 20. Configuration pins characteristics**

Over operating free-air temperature range, unless otherwise noted.

Symbol	Parameter	Conditions	Min	Typ	Max	Unit
<b>Input characteristics</b>						
$V_{IH}$	HIGH-level input voltage		$0.7 \times V_{DD(3V3)}$	-	-	V
$V_{IL}$	LOW-level input voltage				$0.3 \times V_{DD(3V3)}$	V
<b>Weak pull-down characteristics</b>						
$I_{pd}$	pull-down current	$V_I = V_{DD(3V3)}$	15	30	70	$\mu\text{A}$
$I_{pu}$	pull-up current	$V_I = 0 \text{ V}$	25	55	90	$\mu\text{A}$
$R_{ext}$	external resistance	external resistor used on configuration pins	-	-	10	k $\Omega$

## 13.9 RST\_N

**Table 21. RST\_N characteristics**

Over operating free-air temperature range, unless otherwise noted.

Symbol	Parameter	Conditions	Min	Typ	Max	Unit
<b>Input characteristics</b>						
$V_{IH}$	HIGH-level input voltage		$0.7 \times V_{DD(3V3)}$	-	-	V
$V_{IL}$	LOW-level input voltage		-	-	$0.3 \times V_{DD(3V3)}$	V
$I_{pu(RST\_N)}$	pull-up current on pin RST_N	$V_I = 0\text{ V}$	25	55	90	$\mu\text{A}$



14. Package outline

HVQFN32: plastic thermal enhanced very thin quad flat package; no leads; 32 terminals; body 5 x 5 x 0.85 mm

SOT617-3



Fig 9. Package outline SOT617-3 (HVQFN32)

## 15. Packing information

### 15.1 Packing method

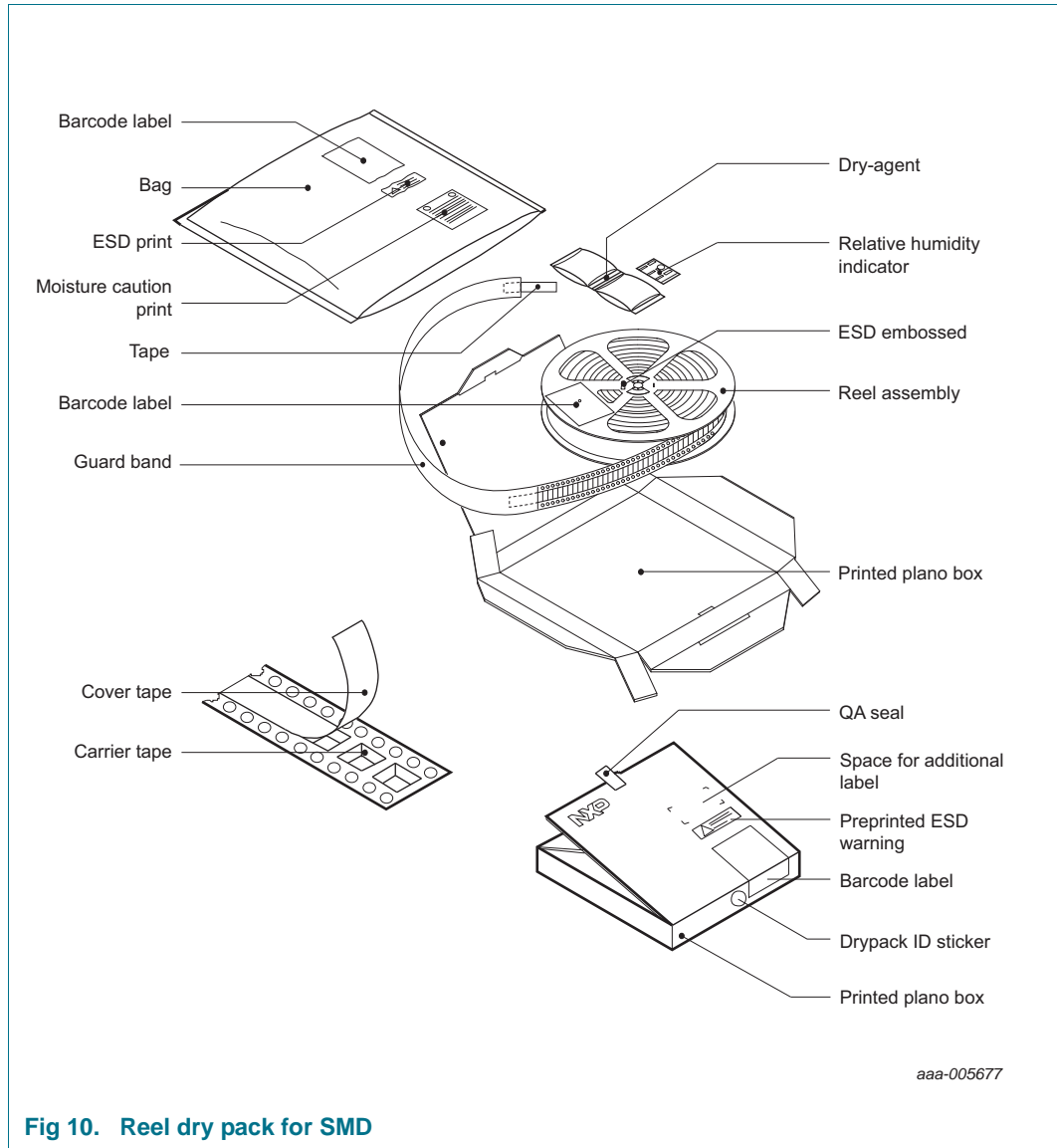

**Table 22. Dimensions and quantities**

Reel dimensions d × w (mm) <sup>[1]</sup>	SPQ/PQ (pcs)	Reels per box	Outer box dimensions l × w × h (mm)
330 × 12	6000	1	341 × 338 × 39

[1] d = reel diameter; w = tape width.

### 15.2 Product orientation



### 15.3 Carrier tape dimensions

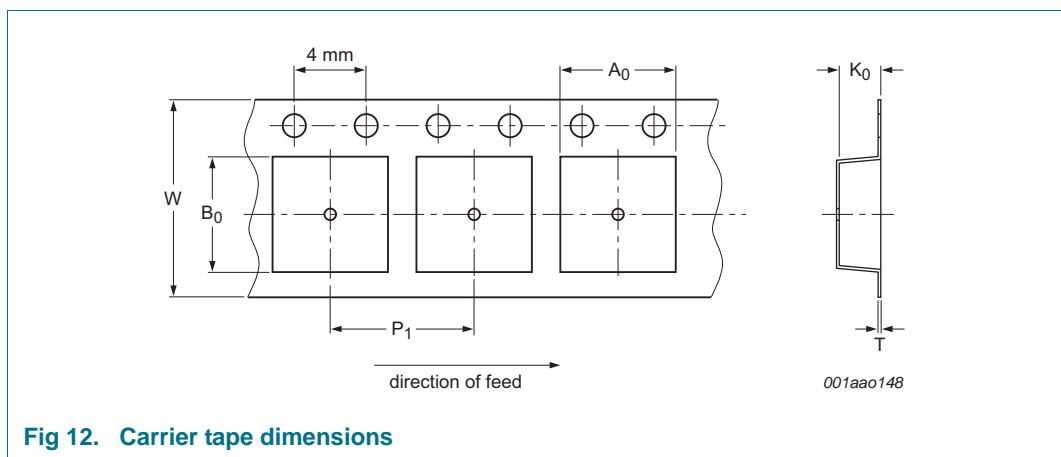

**Table 23. Carrier tape dimensions**

In accordance with IEC 60286-3.

A <sub>0</sub> (mm)	B <sub>0</sub> (mm)	K <sub>0</sub> (mm)	T (mm)	P <sub>1</sub> (mm)	W (mm)
5.3 ± 0.1	5.3 ± 0.1	1.10 ± 0.1	0.30 ± 0.05	8 ± 0.1	12 ± 0.3

15.4 Reel dimensions



Fig 13. Schematic view of reel

Table 24. Reel dimensions  
In accordance with IEC 60286-3.

A [nom] (mm)	W2 [max] (mm)	B [min] (mm)	C [min] (mm)	D [min] (mm)
330	18.4	1.5	12.8	20.2

15.5 Barcode label

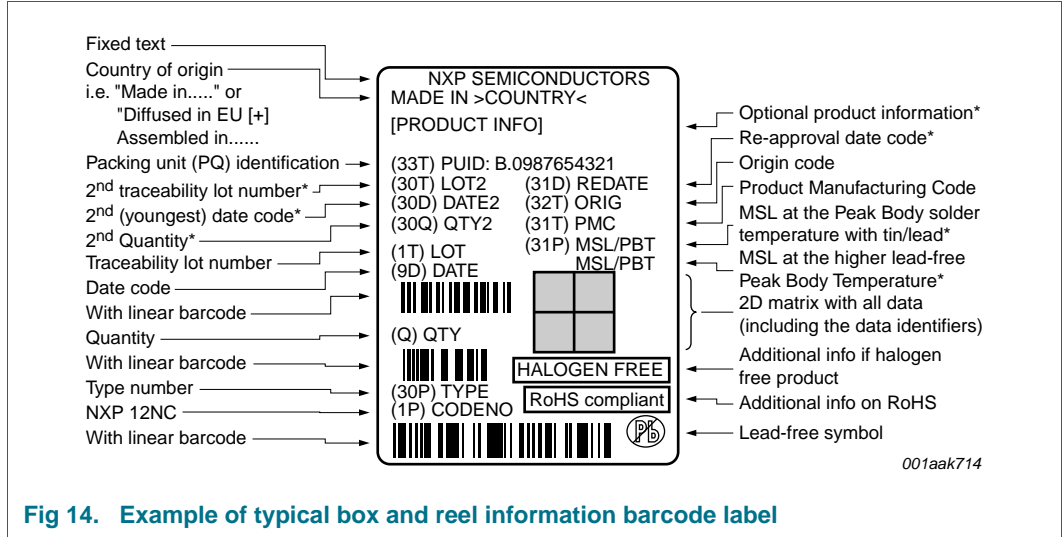

Fig 14. Example of typical box and reel information barcode label

Table 25. Barcode label dimensions

Box barcode label l × w (mm)	Reel barcode label l × w (mm)
100 × 75	100 × 75

## 16. Soldering of SMD packages

This text provides a very brief insight into a complex technology. A more in-depth account of soldering ICs can be found in Application Note *AN10365 "Surface mount reflow soldering description"*.

### 16.1 Introduction to soldering

Soldering is one of the most common methods through which packages are attached to Printed Circuit Boards (PCBs), to form electrical circuits. The soldered joint provides both the mechanical and the electrical connection. There is no single soldering method that is ideal for all IC packages. Wave soldering is often preferred when through-hole and Surface Mount Devices (SMDs) are mixed on one printed wiring board; however, it is not suitable for fine pitch SMDs. Reflow soldering is ideal for the small pitches and high densities that come with increased miniaturization.

### 16.2 Wave and reflow soldering

Wave soldering is a joining technology in which the joints are made by solder coming from a standing wave of liquid solder. The wave soldering process is suitable for the following:

- Through-hole components
- Leaded or leadless SMDs, which are glued to the surface of the printed circuit board

Not all SMDs can be wave soldered. Packages with solder balls, and some leadless packages which have solder lands underneath the body, cannot be wave soldered. Also, leaded SMDs with leads having a pitch smaller than ~0.6 mm cannot be wave soldered, due to an increased probability of bridging.

The reflow soldering process involves applying solder paste to a board, followed by component placement and exposure to a temperature profile. Leaded packages, packages with solder balls, and leadless packages are all reflow solderable.

Key characteristics in both wave and reflow soldering are:

- Board specifications, including the board finish, solder masks and vias
- Package footprints, including solder thieves and orientation
- The moisture sensitivity level of the packages
- Package placement
- Inspection and repair
- Lead-free soldering versus SnPb soldering

### 16.3 Wave soldering

Key characteristics in wave soldering are:

- Process issues, such as application of adhesive and flux, clinching of leads, board transport, the solder wave parameters, and the time during which components are exposed to the wave
- Solder bath specifications, including temperature and impurities

### 16.4 Reflow soldering

Key characteristics in reflow soldering are:

- Lead-free versus SnPb soldering; note that a lead-free reflow process usually leads to higher minimum peak temperatures (see [Figure 15](#)) than a SnPb process, thus reducing the process window
- Solder paste printing issues including smearing, release, and adjusting the process window for a mix of large and small components on one board
- Reflow temperature profile; this profile includes preheat, reflow (in which the board is heated to the peak temperature) and cooling down. It is imperative that the peak temperature is high enough for the solder to make reliable solder joints (a solder paste characteristic). In addition, the peak temperature must be low enough that the packages and/or boards are not damaged. The peak temperature of the package depends on package thickness and volume and is classified in accordance with [Table 26](#) and [27](#)

**Table 26. SnPb eutectic process (from J-STD-020D)**

Package thickness (mm)	Package reflow temperature (°C)	
	Volume (mm <sup>3</sup> )	
	< 350	≥ 350
< 2.5	235	220
≥ 2.5	220	220

**Table 27. Lead-free process (from J-STD-020D)**

Package thickness (mm)	Package reflow temperature (°C)		
	Volume (mm <sup>3</sup> )		
	< 350	350 to 2000	> 2000
< 1.6	260	260	260
1.6 to 2.5	260	250	245
> 2.5	250	245	245

Moisture sensitivity precautions, as indicated on the packing, must be respected at all times.

Studies have shown that small packages reach higher temperatures during reflow soldering, see [Figure 15](#).



For further information on temperature profiles, refer to Application Note AN10365 “Surface mount reflow soldering description”.



### 17. Soldering: PCB footprints

Footprint information for reflow soldering of HVQFN32 package

SOT617-3

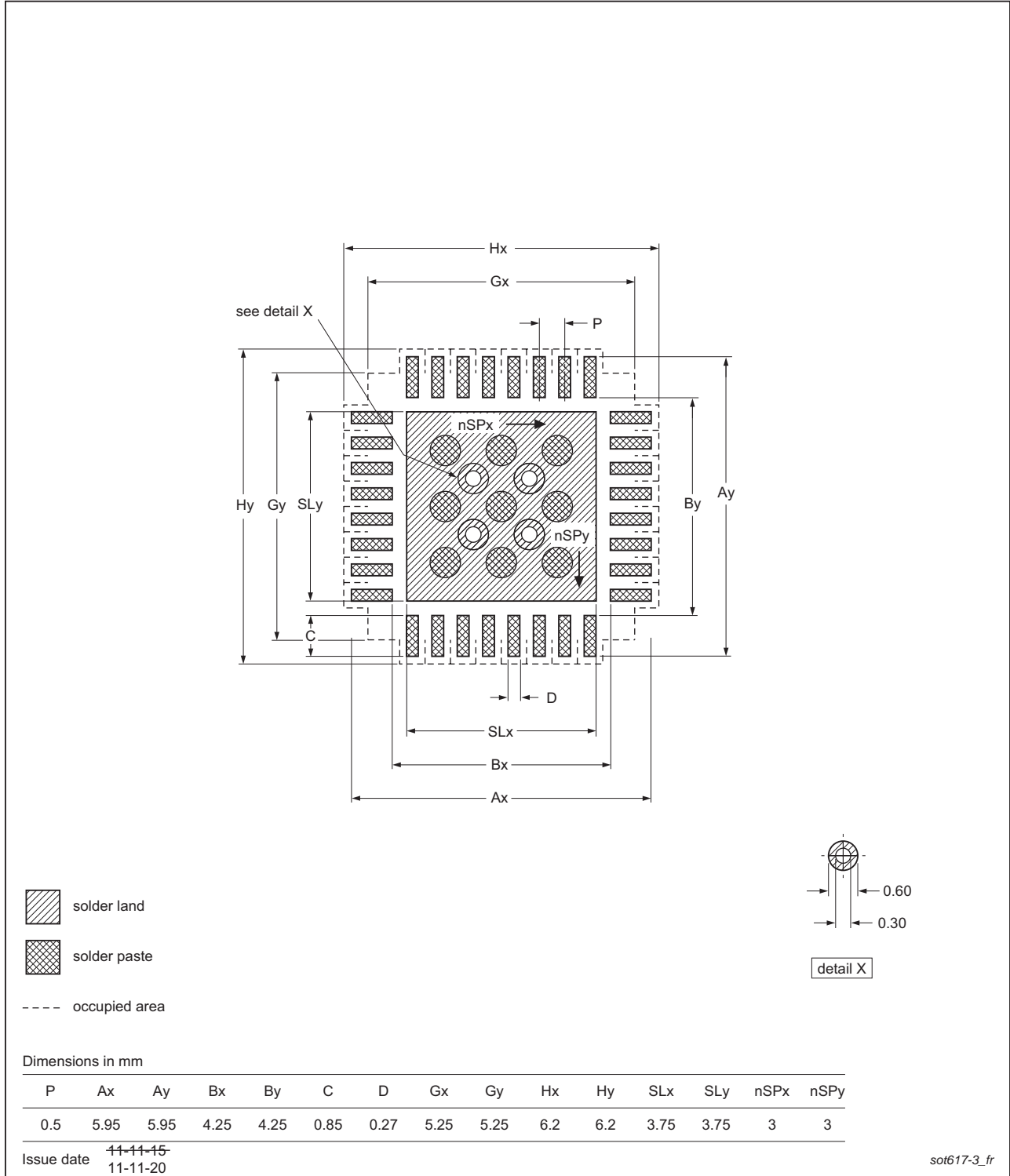

Fig 16. PCB footprint for SOT617-3 (HVQFN32); reflow soldering

## 18. Abbreviations

Table 28. Abbreviations

Acronym	Description
AUX CH	Auxiliary Channel
BER	Bit Error Rate
bpc	bits per color
bpp	bits per pixel
BoM	Bill of Materials
CDM	Charged-Device Model
CEA	Consumer Electronic Association
CMOS	Complementary Metal-Oxide Semiconductor
CVT	Coordinated Video Timings
CVT RB	CVT Reduced Blanking
DAC	Digital-to-Analog Converter
DDC	Display Data Channel
DJ	Deterministic Jitter
DP	DisplayPort (VESA)
DPCD	DisplayPort Configuration Data
ECC	Error Correction Code
EDID	Extended Display Identification Data
eDP	embedded DisplayPort
ESD	ElectroStatic Discharge
HBM	Human Body Model
HBR	High Bit Rate
HDCP	High-bandwidth Digital Content Protection
HPD	Hot Plug Detect
I <sup>2</sup> C-bus	Inter-Integrated Circuit bus
IEC	International Electrotechnical Commission
I/O	Input/Output
LSB	Least Significant Bit
MCCS	Monitor Control Command Set (VESA)
MSB	Most Significant Bit
QXGA	Quad eXtended Graphics Array
RB	Reduced Blanking
RBR	Reduced Bit Rate
RGB	Red/Green/Blue
ROM	Read-Only Memory
SSC	Spread Spectrum Clocking
SVGA	Super Video Graphics Array
SXGA	Super eXtended Graphics Array
TJ	Total Jitter
UI	Unit Interval

Table 28. Abbreviations ...continued

Acronym	Description
UXGA	Ultra eXtended Graphics Array
VESA	Video Electronics Standards Association
VGA	Video Graphics Array
VSIS	Video Signal Interface Standard
WUXGA	Wide Ultra eXtended Graphics Array
XGA	eXtended Graphics Array

## 19. References

- [1] **VESA DisplayPort Standard** — Version 1, Revision 2a; March 2012
- [2] **Display Data Channel Command Interface Standard** — Version 1.1; October 29, 2004
- [3] **Video Signal Standard (VSIS)** — Version 1, Rev. 2; December 12, 2002
- [4] **IEC 61000-4-2, Electromagnetic compatibility (EMC) - Part 4-2: Testing and measurement techniques** — ElectroStatic Discharge (ESD) immunity test, edition 2.0, 2008-12

## 20. Revision history

Table 29. Revision history

Document ID	Release date	Data sheet status	Change notice	Supersedes
PTN3356R1 v.2.2	20160816	Product data sheet	-	PTN3356R1 v.2.1
Modifications:	<ul style="list-style-type: none"> <li>• Removed 500 piece MOQ</li> </ul>			
PTN3356R1 v.2.1	20150716	Product data sheet	-	PTN3356R1 v.2
Modifications:	<ul style="list-style-type: none"> <li>• Removed "COMPANY CONFIDENTIAL" watermark</li> </ul>			
PTN3356R1 v.2	20150629	Product data sheet	-	PTN3356R1 v.1
Modifications:	<ul style="list-style-type: none"> <li>• Updated <a href="#">Figure 7</a></li> <li>• Changed data sheet status to Product</li> <li>• ESD HBM changed to 7 kV</li> <li>• <a href="#">Table 2</a>: Added 500 piece minimum order quantity</li> </ul>			
PTN3356R1 v.1	20140911	Objective data sheet	-	-

## 21. Legal information

### 21.1 Data sheet status

Document status <sup>[1][2]</sup>	Product status <sup>[3]</sup>	Definition
Objective [short] data sheet	Development	This document contains data from the objective specification for product development.
Preliminary [short] data sheet	Qualification	This document contains data from the preliminary specification.
Product [short] data sheet	Production	This document contains the product specification.

[1] Please consult the most recently issued document before initiating or completing a design.

[2] The term 'short data sheet' is explained in section "Definitions".

[3] The product status of device(s) described in this document may have changed since this document was published and may differ in case of multiple devices. The latest product status information is available on the Internet at URL <http://www.nxp.com>.

### 21.2 Definitions

**Draft** — The document is a draft version only. The content is still under internal review and subject to formal approval, which may result in modifications or additions. NXP Semiconductors does not give any representations or warranties as to the accuracy or completeness of information included herein and shall have no liability for the consequences of use of such information.

**Short data sheet** — A short data sheet is an extract from a full data sheet with the same product type number(s) and title. A short data sheet is intended for quick reference only and should not be relied upon to contain detailed and full information. For detailed and full information see the relevant full data sheet, which is available on request via the local NXP Semiconductors sales office. In case of any inconsistency or conflict with the short data sheet, the full data sheet shall prevail.

**Product specification** — The information and data provided in a Product data sheet shall define the specification of the product as agreed between NXP Semiconductors and its customer, unless NXP Semiconductors and customer have explicitly agreed otherwise in writing. In no event however, shall an agreement be valid in which the NXP Semiconductors product is deemed to offer functions and qualities beyond those described in the Product data sheet.

### 21.3 Disclaimers

**Limited warranty and liability** — Information in this document is believed to be accurate and reliable. However, NXP Semiconductors does not give any representations or warranties, expressed or implied, as to the accuracy or completeness of such information and shall have no liability for the consequences of use of such information. NXP Semiconductors takes no responsibility for the content in this document if provided by an information source outside of NXP Semiconductors.

In no event shall NXP Semiconductors be liable for any indirect, incidental, punitive, special or consequential damages (including - without limitation - lost profits, lost savings, business interruption, costs related to the removal or replacement of any products or rework charges) whether or not such damages are based on tort (including negligence), warranty, breach of contract or any other legal theory.

Notwithstanding any damages that customer might incur for any reason whatsoever, NXP Semiconductors' aggregate and cumulative liability towards customer for the products described herein shall be limited in accordance with the *Terms and conditions of commercial sale* of NXP Semiconductors.

**Right to make changes** — NXP Semiconductors reserves the right to make changes to information published in this document, including without limitation specifications and product descriptions, at any time and without notice. This document supersedes and replaces all information supplied prior to the publication hereof.

**Suitability for use** — NXP Semiconductors products are not designed, authorized or warranted to be suitable for use in life support, life-critical or safety-critical systems or equipment, nor in applications where failure or malfunction of an NXP Semiconductors product can reasonably be expected to result in personal injury, death or severe property or environmental damage. NXP Semiconductors and its suppliers accept no liability for inclusion and/or use of NXP Semiconductors products in such equipment or applications and therefore such inclusion and/or use is at the customer's own risk.

**Applications** — Applications that are described herein for any of these products are for illustrative purposes only. NXP Semiconductors makes no representation or warranty that such applications will be suitable for the specified use without further testing or modification.

Customers are responsible for the design and operation of their applications and products using NXP Semiconductors products, and NXP Semiconductors accepts no liability for any assistance with applications or customer product design. It is customer's sole responsibility to determine whether the NXP Semiconductors product is suitable and fit for the customer's applications and products planned, as well as for the planned application and use of customer's third party customer(s). Customers should provide appropriate design and operating safeguards to minimize the risks associated with their applications and products.

NXP Semiconductors does not accept any liability related to any default, damage, costs or problem which is based on any weakness or default in the customer's applications or products, or the application or use by customer's third party customer(s). Customer is responsible for doing all necessary testing for the customer's applications and products using NXP Semiconductors products in order to avoid a default of the applications and the products or of the application or use by customer's third party customer(s). NXP does not accept any liability in this respect.

**Limiting values** — Stress above one or more limiting values (as defined in the Absolute Maximum Ratings System of IEC 60134) will cause permanent damage to the device. Limiting values are stress ratings only and (proper) operation of the device at these or any other conditions above those given in the Recommended operating conditions section (if present) or the Characteristics sections of this document is not warranted. Constant or repeated exposure to limiting values will permanently and irreversibly affect the quality and reliability of the device.

**Terms and conditions of commercial sale** — NXP Semiconductors products are sold subject to the general terms and conditions of commercial sale, as published at <http://www.nxp.com/profile/terms>, unless otherwise agreed in a valid written individual agreement. In case an individual agreement is concluded only the terms and conditions of the respective agreement shall apply. NXP Semiconductors hereby expressly objects to applying the customer's general terms and conditions with regard to the purchase of NXP Semiconductors products by customer.

**No offer to sell or license** — Nothing in this document may be interpreted or construed as an offer to sell products that is open for acceptance or the grant, conveyance or implication of any license under any copyrights, patents or other industrial or intellectual property rights.

**Export control** — This document as well as the item(s) described herein may be subject to export control regulations. Export might require a prior authorization from competent authorities.

**Non-automotive qualified products** — Unless this data sheet expressly states that this specific NXP Semiconductors product is automotive qualified, the product is not suitable for automotive use. It is neither qualified nor tested in accordance with automotive testing or application requirements. NXP Semiconductors accepts no liability for inclusion and/or use of non-automotive qualified products in automotive equipment or applications.

In the event that customer uses the product for design-in and use in automotive applications to automotive specifications and standards, customer (a) shall use the product without NXP Semiconductors' warranty of the product for such automotive applications, use and specifications, and (b) whenever customer uses the product for automotive applications beyond

NXP Semiconductors' specifications such use shall be solely at customer's own risk, and (c) customer fully indemnifies NXP Semiconductors for any liability, damages or failed product claims resulting from customer design and use of the product for automotive applications beyond NXP Semiconductors' standard warranty and NXP Semiconductors' product specifications.

**Translations** — A non-English (translated) version of a document is for reference only. The English version shall prevail in case of any discrepancy between the translated and English versions.

## 21.4 Trademarks

Notice: All referenced brands, product names, service names and trademarks are the property of their respective owners.

## 22. Contact information

For more information, please visit: <http://www.nxp.com>

For sales office addresses, please send an email to: [salesaddresses@nxp.com](mailto:salesaddresses@nxp.com)

## 23. Contents

<b>1</b>	<b>General description</b> . . . . .	<b>1</b>	15.1	Packing method . . . . .	26
<b>2</b>	<b>Features and benefits</b> . . . . .	<b>1</b>	15.2	Product orientation . . . . .	27
2.1	VESA-compliant DisplayPort converter . . . . .	1	15.3	Carrier tape dimensions . . . . .	27
2.2	VESA-compliant eDP extensions . . . . .	1	15.4	Reel dimensions . . . . .	28
2.3	DDC channel output . . . . .	1	15.5	Barcode label . . . . .	29
2.4	Analog video output . . . . .	2	<b>16</b>	<b>Soldering of SMD packages</b> . . . . .	<b>30</b>
2.5	General features . . . . .	2	16.1	Introduction to soldering . . . . .	30
<b>3</b>	<b>Applications</b> . . . . .	<b>3</b>	16.2	Wave and reflow soldering . . . . .	30
<b>4</b>	<b>Ordering information</b> . . . . .	<b>3</b>	16.3	Wave soldering . . . . .	30
4.1	Ordering options . . . . .	3	16.4	Reflow soldering . . . . .	31
<b>5</b>	<b>Functional diagram</b> . . . . .	<b>4</b>	<b>17</b>	<b>Soldering: PCB footprints</b> . . . . .	<b>33</b>
<b>6</b>	<b>Pinning information</b> . . . . .	<b>5</b>	<b>18</b>	<b>Abbreviations</b> . . . . .	<b>34</b>
6.1	Pinning . . . . .	5	<b>19</b>	<b>References</b> . . . . .	<b>35</b>
6.2	Pin description . . . . .	5	<b>20</b>	<b>Revision history</b> . . . . .	<b>35</b>
<b>7</b>	<b>Functional description</b> . . . . .	<b>7</b>	<b>21</b>	<b>Legal information</b> . . . . .	<b>36</b>
7.1	DisplayPort Main Link . . . . .	7	21.1	Data sheet status . . . . .	36
7.2	DisplayPort auxiliary channel (AUX CH) . . . . .	7	21.2	Definitions . . . . .	36
7.3	DPCD registers . . . . .	8	21.3	Disclaimers . . . . .	36
7.3.1	PTN3356R1 specific DPCD register settings . . . . .	8	21.4	Trademarks . . . . .	37
7.4	VGA monitor detection . . . . .	10	<b>22</b>	<b>Contact information</b> . . . . .	<b>37</b>
7.5	EDID handling . . . . .	10	<b>23</b>	<b>Contents</b> . . . . .	<b>38</b>
7.6	Triple 8-bit video DACs and VGA outputs . . . . .	10			
7.6.1	DAC reference resistor . . . . .	10			
<b>8</b>	<b>Power-up and reset</b> . . . . .	<b>11</b>			
<b>9</b>	<b>Configurability</b> . . . . .	<b>11</b>			
<b>10</b>	<b>Application design-in information</b> . . . . .	<b>12</b>			
10.1	Display resolution . . . . .	15			
10.2	Power supply filter . . . . .	16			
10.3	DAC terminations . . . . .	16			
10.4	Timing reference . . . . .	17			
<b>11</b>	<b>Limiting values</b> . . . . .	<b>18</b>			
<b>12</b>	<b>Recommended operating conditions</b> . . . . .	<b>18</b>			
<b>13</b>	<b>Characteristics</b> . . . . .	<b>19</b>			
13.1	Current consumption, power dissipation and thermal characteristics . . . . .	19			
13.2	DisplayPort receiver main link . . . . .	20			
13.3	DisplayPort receiver AUX CH . . . . .	21			
13.4	HPD characteristics . . . . .	22			
13.5	DDC/CFG1, CFG2 characteristics . . . . .	22			
13.6	DAC . . . . .	23			
13.7	HSYNC, VSYNC characteristics . . . . .	23			
13.8	Configuration pins CFG3, CFG5, TESTMODE . . . . .	23			
13.9	RST_N . . . . .	24			
<b>14</b>	<b>Package outline</b> . . . . .	<b>25</b>			
<b>15</b>	<b>Packing information</b> . . . . .	<b>26</b>			

Please be aware that important notices concerning this document and the product(s) described herein, have been included in section 'Legal information'.

© NXP Semiconductors N.V. 2016.

All rights reserved.

For more information, please visit: <http://www.nxp.com>

For sales office addresses, please send an email to: [salesaddresses@nxp.com](mailto:salesaddresses@nxp.com)

Date of release: 16 August 2016

Document identifier: PTN3356R1

Компания «Life Electronics» занимается поставками электронных компонентов импортного и отечественного производства от производителей и со складов крупных дистрибьюторов Европы, Америки и Азии.

С конца 2013 года компания активно расширяет линейку поставок компонентов по направлению коаксиальный кабель, кварцевые генераторы и конденсаторы (керамические, пленочные, электролитические), за счёт заключения дистрибьюторских договоров

Мы предлагаем:

- Конкурентоспособные цены и скидки постоянным клиентам.
- Специальные условия для постоянных клиентов.
- Подбор аналогов.
- Поставку компонентов в любых объемах, удовлетворяющих вашим потребностям.
- Приемлемые сроки поставки, возможна ускоренная поставка.
- Доставку товара в любую точку России и стран СНГ.
- Комплексную поставку.
- Работу по проектам и поставку образцов.
- Формирование склада под заказчика.
- Сертификаты соответствия на поставляемую продукцию (по желанию клиента).
- Тестирование поставляемой продукции.
- Поставку компонентов, требующих военную и космическую приемку.
- Входной контроль качества.
- Наличие сертификата ISO.

В составе нашей компании организован Конструкторский отдел, призванный помогать разработчикам, и инженерам.

Конструкторский отдел помогает осуществить:

- Регистрацию проекта у производителя компонентов.
- Техническую поддержку проекта.
- Защиту от снятия компонента с производства.
- Оценку стоимости проекта по компонентам.
- Изготовление тестовой платы монтаж и пусконаладочные работы.



Тел: +7 (812) 336 43 04 (многоканальный)

Email: [org@lifeelectronics.ru](mailto:org@lifeelectronics.ru)