

Introducing Mezalok Connector

*(High Reliability Mezzanine
Connector)*

KEY FEATURES

60 and 114 positions

Mini-Box contact system provides 4 points of contact for ultra reliability

LCP plastic housings offer superior thermal stability and are low-outgassing

Compliant BGA board attach supports standard surface mount processing and excellent thermal stability

114 position footprint compatible to XMC footprint and all dimensional constraints

DESCRIPTION

Rugged surface mount mezzanine connector incorporating “super-redundant” Mini-Box contact system for separable interface.

Designed for 10mm and 12mm stack heights in both 60 and 114 positions.

APPLICATIONS

Stacking or mezzanine applications

114 position is designed to support VITA 61 XMC architecture as rugged alternative to VITA 42 XMC

60 position designed for custom architecture stacking applications

ELECTRICAL

Stacking or mezzanine applications

114 position is designed to support VITA 61 XMC architecture as rugged alternative to VITA 42 XMC

60 position designed for custom architecture stacking applications

MECHANICAL

500 mating cycles durability

Mating force: 0.30 lb. max. times number of contacts

-65°C to +125°C operating temperature

Shock and vibration per VITA 47 requirements

MATERIALS

Pin Assembly: LCP plastic housings, white in color

Socket Assembly: LCP plastic housings, white in color

Contacts: High Performance Copper Alloy, 50μ” Au in mating interface (Sn/Pb and SAC305 solder balls are available)

STANDARDS & SPECS

114 position conforms to requirement of VITA 61 (VITA 42 Alternate)

VITA 42 and VITA 61 are not intermateable, but are footprint and XMC architecture compatible

APPLICATION TOOLING

Product is installed via standard BGA surface mount processes.

ORDERING INFORMATION



4 pin contact

Part Number	Description
114 Position:	
2102060-1	Assembly, pin housing, tin-lead, 1.27 μ m gold
2102060-2	Assembly, pin housing, lead-free, 1.27 μ m gold
2102060-3	Assembly, pin housing, tin-lead, 0.76 μ m gold
2102060-4	Assembly, pin housing, lead-free, 0.76 μ m gold
2102061-1	Assembly, socket housing, tin-lead, 10 mm, 1.27 μ m gold
2102061-2	Assembly, socket housing, lead-free, 10 mm, 1.27 μ m gold
2102061-3	Assembly, socket housing, tin-lead, 12 mm, 1.27 μ m gold
2102061-4	Assembly, socket housing, lead-free, 12 mm, 1.27 μ m gold
2102061-5	Assembly, socket housing, tin-lead, 10 mm, 0.76 μ m gold
2102061-6	Assembly, socket housing, lead-free, 10 mm, 0.76 μ m gold
2102061-7	Assembly, socket housing, tin-lead, 12 mm, 0.76 μ m gold
2102061-8	Assembly, socket housing, lead-free, 12 mm, 0.76 μ m gold
2102061-9	Assembly, socket housing, tin-lead, 18 mm, 1.27 μ m gold
1-2102061-0	Assembly, socket housing, lead-free, 18 mm, 1.27 μ m gold
1-2102061-1	Assembly, socket housing, tin-lead, 18 mm, 0.76 μ m gold
1-2102061-2	Assembly, socket housing, lead-free, 18 mm, 0.76 μ m gold
60 Position:	
2102079-1	Assembly, pin housing, tin-lead, 1.27 μ m gold
2102079-2	Assembly, pin housing, lead-free, 1.27 μ m gold
2102079-3	Assembly, pin housing, tin-lead, 0.76 μ m gold
2102079-4	Assembly, pin housing, lead-free, 0.76 μ m gold
2102080-1	Assembly, socket housing, tin-lead, 10 mm, 1.27 μ m gold
2102080-2	Assembly, socket housing, lead-free, 10 mm, 1.27 μ m gold
2102080-3	Assembly, socket housing, tin-lead, 12 mm, 1.27 μ m gold
2102080-4	Assembly, socket housing, tin-lead, 12 mm, 1.27 μ m gold
2102080-5	Assembly, socket housing, tin-lead, 10 mm, 0.76 μ m gold
2102080-6	Assembly, socket housing, lead-free, 10 mm, 0.76 μ m gold
2102080-7	Assembly, socket housing, tin-lead, 12 mm, 0.76 μ m gold
2102080-8	Assembly, socket housing, lead-free, 12 mm, 0.76 μ m gold

Pin — 2102060

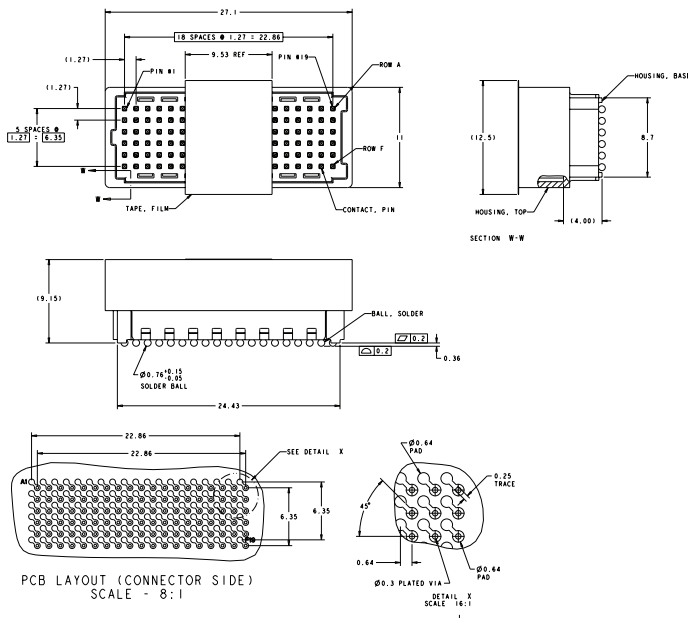

Socket — 2102061

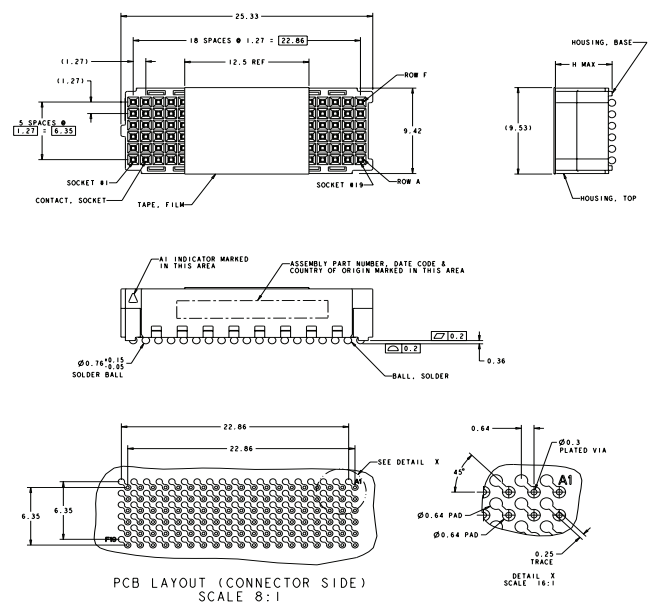

FOR MORE INFORMATION

Technical Support

Internet: www.tycoelectronics.com/ADM
E-mail: product.info@tycoelectronics.com

USA: +1 (800) 522-6752
Canada: +1 (905) 470-4425
Mexico: +52 (0) 55-1106-0814
C. America: +52 (0) 55-1106-0814
South America: +55 (0) 11-2103-6000
Germany: +49 (0) 6251-133-1999
Great Britain: +44 (0) 8706-080208
France: +33 (0) 1-3420-8686
Netherlands: +31 (0) 73-6246-999
China: +86 (0) 400-820-6015

Tyco Electronics Corporation
Harrisburg, PA

tycoelectronics.com

©2010 Tyco Electronics Corporation

2-1773457-3 — ADM — FP — 2.5M — 10/10
TE (logo) and Tyco Electronics are trademarks.

 **Tyco Electronics**
Our commitment. Your advantage.

Компания «Life Electronics» занимается поставками электронных компонентов импортного и отечественного производства от производителей и со складов крупных дистрибьюторов Европы, Америки и Азии.

С конца 2013 года компания активно расширяет линейку поставок компонентов по направлению коаксиальный кабель, кварцевые генераторы и конденсаторы (керамические, пленочные, электролитические), за счёт заключения дистрибьюторских договоров

Мы предлагаем:

- Конкурентоспособные цены и скидки постоянным клиентам.
- Специальные условия для постоянных клиентов.
- Подбор аналогов.
- Поставку компонентов в любых объемах, удовлетворяющих вашим потребностям.
- Приемлемые сроки поставки, возможна ускоренная поставка.
- Доставку товара в любую точку России и стран СНГ.
- Комплексную поставку.
- Работу по проектам и поставку образцов.
- Формирование склада под заказчика.
- Сертификаты соответствия на поставляемую продукцию (по желанию клиента).
- Тестирование поставляемой продукции.
- Поставку компонентов, требующих военную и космическую приемку.
- Входной контроль качества.
- Наличие сертификата ISO.

В составе нашей компании организован Конструкторский отдел, призванный помогать разработчикам, и инженерам.

Конструкторский отдел помогает осуществить:

- Регистрацию проекта у производителя компонентов.
- Техническую поддержку проекта.
- Защиту от снятия компонента с производства.
- Оценку стоимости проекта по компонентам.
- Изготовление тестовой платы монтаж и пусконаладочные работы.



Тел: +7 (812) 336 43 04 (многоканальный)

Email: org@lifeelectronics.ru