

POWER RELAY

1 POLE - 25A - 1.5mm contact gap

FTR-K3-WG Series

■ FEATURES

- 1 pole, 25A
- 1 Form A
- Contact gap 1.5mm
 - Surge strength (B/T open contacts) 2.5kV
 - Compliance with European photovoltaic standard (VDE0126)
- High insulation in small package (between coil and contact)
 - Insulation distance: Clearance > 6.4mm
Creepage > 9.5mm
 - Dielectric strength: 5,000VAC
 - Surge strength: 8,500V
- Coil holding voltage can be reduced up to 35% of nominal coil voltage (ambient temperature; +20 °C, contact current; 25A)
Power consumption at the lowest coil holding voltage; 95mW
* Coil holding voltage is the coil voltage after 100ms of applied nominal coil voltage
- Flammability UL94V-0 (plastics)
- Cadmium-free contacts
- Flux free, cat. RTII protection
- RoHS compliant
Please see page 6 for more information



■ PARTNUMBER INFORMATION

[Example] FTR-K3 A B 012 W - WG
 (a) (b) (c) (d) (e) (f)

(a)	Relay type	FTR-K3 : FTR-K3-Series
(b)	Contact configuration	A : 1 form A / PCB type
(c)	Coil power	B : Standard type (780mW)
(d)	Coil rated voltage	012 : 5.....48 VDC Coil rating table at page 3
(e)	Contact material	W : Silver alloy
(f)	Option code	WG : Contact gap 1.5mm

Actual marking does not carry the type name : "FTR"

E.g.: Ordering code: FTR-K3AB012W-WG

Actual marking: K3AB012W-WG

FTR-K3-WG SERIES

■ SPECIFICATION

Item	FTR-K3-WG		
Contact Data	Configuration	1 form A	
	Material	Silver alloy	
	Resistance (initial)	Max. 100mΩ at 1A, 6VDC	
	Contact rating	25A, 250VAC (resistive)	
	Max. carrying current	25A	
	Max. switching voltage	250VAC	
	Max. switching power	6,250VA	
	Max. switching current	25A	
	Min. switching load *1	100mA, 5VDC (reference value)	
Life	Mechanical	Min. 2 x 10 ⁶ operations	
	Electrical (resistive)	25A / 250VAC, min. 100 x 10 ³ operations	
	Electrical (inductive)	Endurance: 25A, 250VAC, cos φ = 0.8, min. 30 x 10 ³ operations Overload: 37.5A, 250VAC, cos φ = 0.8, min. 50 operations	
Coil Data	Rated power (at 20 °C)	Approximately 780mW	
	Operate power (at 20 °C)	Approximately 380mW	
	Coil power at holding voltage	95mW (35% of nominal coil voltage)	
	Holding voltage *2	35~120% of nominal coil voltage (25A at +20 °C) 40~80% of nominal coil voltage (25A at +85 °C)	
	Operating temperature range	-40 °C to +60 °C (coil nominal voltage) -40 °C to +85 °C (holding voltage; 40~80% of nominal coil voltage)	
Timing Data	Operate (at nominal voltage)	Max. 20ms (without bounce)	
	Release (at nominal voltage)	Max. 10ms (no diode, without bounce)	
Insulation	Contact gap (initial)	Min. 1.5 mm	
	Resistance	Min. 1,000MΩ at 500VDC	
	Dielectric strength	Open contacts	2,500VAC, 1min.
		Coil and contacts	5,000VAC, 1min.
	Surge strength	Coil to contacts	8,500V / 1.2 x 50μs standard wave
Other	Vibration resistance	Misoperation	10 to 55Hz double amplitude 1.5 mm
		Endurance	10 to 55Hz double amplitude 1.5 mm
	Shock resistance	Misoperation	Min. 200m/s ² (11 ± 1ms)
		Endurance	Min. 1,000m/s ² (6 ± 1ms)
	Weight		Approximately 25 g

*1 Minimum switching loads mentioned above are reference values. Please perform the confirmation test with actual load before production since reference values may vary according to switching frequencies, environmental conditions and expected reliability levels.

*2 Reduction of minimum coil holding voltage to maximum coil voltage range, after 100msec energizing with nominal coil voltage.

FTR-K3-WG SERIES

■ COIL RATING

Coil Code	Rated Coil Voltage (VDC)	Coil Resistance +/- 10% (Ohm)	Must Operate Voltage (VDC) *1	Must Release Voltage (VDC) *1	Min. Non Release Voltage (VDC) *1	Rated Power +/- 10% (mW)
005	5	32	3.5	0.5	1.75	Approx. 780 (97)*2
006	6	46	4.2	0.6	2.1	
009	9	105	6.3	0.9	3.15	
012	12	185	8.4	1.2	4.2	
018	18	415	12.6	1.8	6.3	
024	24	740	16.8	2.4	8.4	
048	48	2,955	33.6	4.8	16.8	

Note: All values in the table are valid for 20°C and zero contact current.

*1 Specified operate values are valid for pulse wave voltage.

*2 This value is the coil power at 35% of nominal voltage at 20°C.

■ SAFETY STANDARDS

Type	Compliance	Contact rating
UL	UL 508 E63614	25A, 277VAC (resistive, at 60 °C) 1HP, 125VAC (at 60 °C) 2HP, 277VAC, 100x10 ³ (at 60 °C)
VDE	IEC61810-1	25A, 250VAC (cosφ =1 at 60 °C)
CQC	GB15092.1, GB8898 GB/T21711.1 04001009179	20A, 250VAC

FTR-K3-WG SERIES

■ REFERENCE DATA

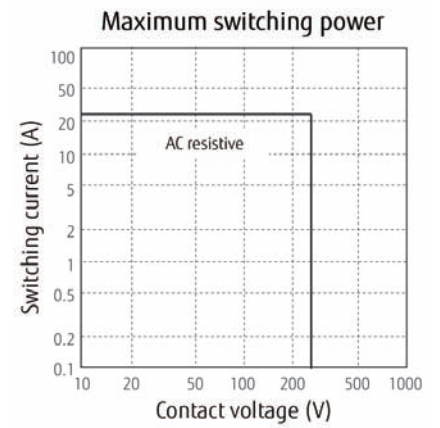
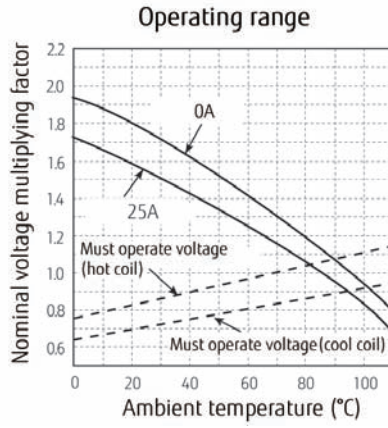
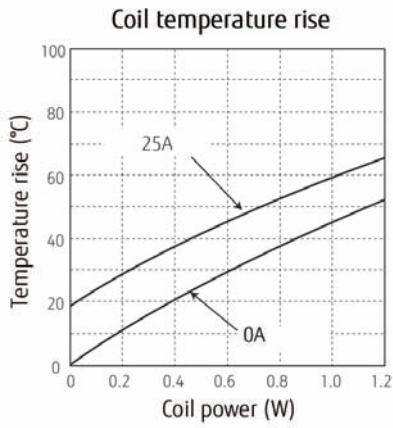

Electrical life tests (resistive load)

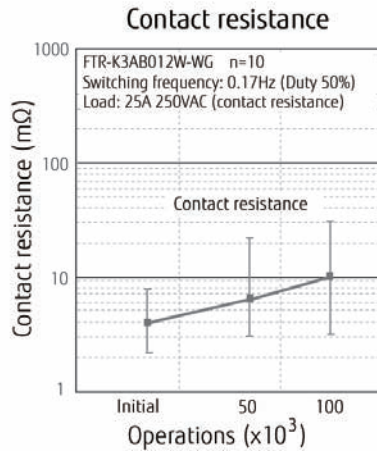
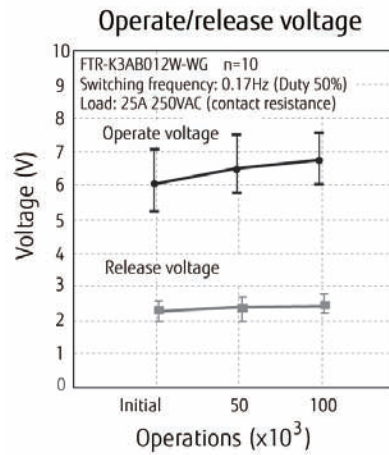

FTR-K3-WG SERIES

■ DIMENSIONS

● Dimensions

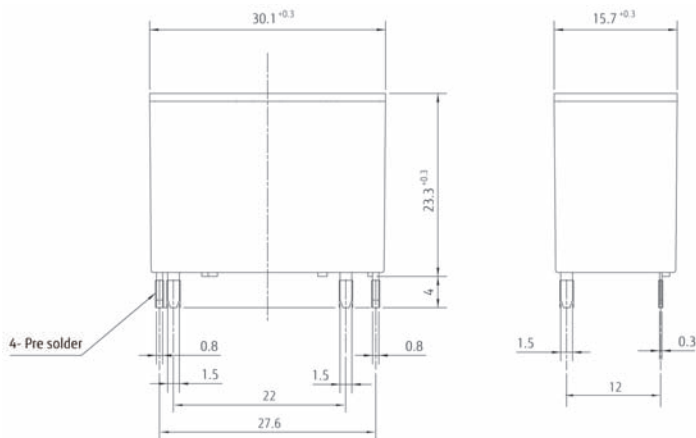

● Schematics (BOTTOM VIEW)

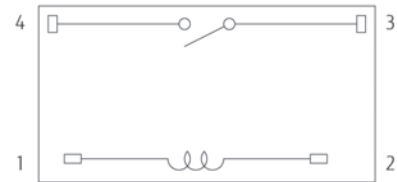

● PC board mounting hole layout (BOTTOM VIEW)

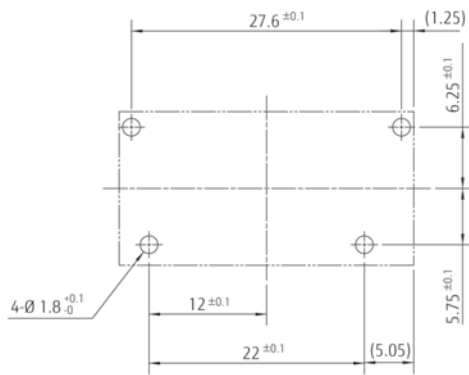

Unit: mm

RoHS Compliance and Lead Free Information

1. General Information

- All signal and power relays produced by Fujitsu Components are compliant with RoHS directive 2002/95EC including amendments.
- Cadmium as used in electrical contacts is exempted from the RoHS directives on October 21st, 2005. (Amendment to Directive 2002/95/EC)
- All of our signal and power relays are lead-free. Please refer to Lead-Free Status Info for older date codes at: <http://www.fujitsu.com/us/downloads/MICRO/fcai/relays/lead-free-letter.pdf>
- Lead free solder plating on relay terminals is Sn-3.0Ag-0.5Cu, unless otherwise specified. This material has been verified to be compatible with PbSn assembly process.

2. Recommended Lead Free Solder Profile

- **Recommended solder Sn-3.0Ag-0.5Cu.**

Flow Solder condition:

Pre-heating: maximum 120°C
Soldering: dip within 5 sec. at
260°C solder bath

Solder by Soldering Iron:

Soldering Iron
Temperature: maximum 360°C
Duration: maximum 3 sec.

We highly recommend that you confirm your actual solder conditions

3. Moisture Sensitivity

- Moisture Sensitivity Level standard is not applicable to electromechanical relays, unless otherwise indicated.

4. Tin Whiskers

- Dipped SnAgCu solder is known as presenting a low risk to tin whisker development. No considerable length whisker was found by our in house test.

Fujitsu Components International Headquarter Offices

<p>Japan Fujitsu Component Limited Gotanda-Chuo Building 3-5, Higashigotanda 2-chome, Shinagawa-ku Tokyo 141, Japan Tel: (81-3) 5449-7010 Fax: (81-3) 5449-2626 Email: promothq@ft.ed.fujitsu.com Web: www.fcl.fujitsu.com</p>	<p>Europe Fujitsu Components Europe B.V. Diamantlaan 25 2132 WV Hoofddorp Netherlands Tel: (31-23) 5560910 Fax: (31-23) 5560950 Email: info@fceu.fujitsu.com Web: emea.fujitsu.com/components/</p>
<p>North and South America Fujitsu Components America, Inc. 250 E. Caribbean Drive Sunnyvale, CA 94089 U.S.A. Tel: (1-408) 745-4900 Fax: (1-408) 745-4970 Email: components@us.fujitsu.com Web: http://us.fujitsu.com/components</p>	<p>Asia Pacific Fujitsu Components Asia Ltd. 102E Pasir Panjang Road #01-01 Citilink Warehouse Complex Singapore 118529 Tel: (65) 6375-8560 Fax: (65) 6273-3021 Email: fcal@fcal.fujitsu.com Web: http://www.fujitsu.com/sg/services/micro/components/</p>

©2011 Fujitsu Components Europe B.V. All rights reserved. All trademarks or registered trademarks are the property of their respective owners.

The contents, data and information in this datasheet are provided by Fujitsu Component Ltd. as a service only to its user and only for general information purposes.

The use of the contents, data and information provided in this datasheet is at the users' own risk.

Fujitsu has assembled this datasheet with care and will endeavor to keep the contents, data and information correct, accurate, comprehensive, complete and up to date.

Fujitsu Components Europe B.V. and affiliated companies do however not accept any responsibility or liability on their behalf, nor on behalf of its employees, for any loss or damage, direct, indirect or consequential, with respect to this datasheet, its contents, data, and information and related graphics and the correctness, reliability, accuracy, comprehensiveness, usefulness, availability and completeness thereof.

Nor do Fujitsu Components Europe B.V. and affiliated companies accept on their behalf, nor on behalf of its employees, any responsibility or liability for any representation or warrant of any kind, express or implied, including warranties of any kind for merchantability or fitness for particular use, with respect to these datasheets, its contents, data, information and related graphics and the correctness, reliability, accuracy, comprehensiveness, usefulness, availability and completeness thereof. Rev. July 13, 2011

Компания «Life Electronics» занимается поставками электронных компонентов импортного и отечественного производства от производителей и со складов крупных дистрибьюторов Европы, Америки и Азии.

С конца 2013 года компания активно расширяет линейку поставок компонентов по направлению коаксиальный кабель, кварцевые генераторы и конденсаторы (керамические, пленочные, электролитические), за счёт заключения дистрибьюторских договоров

Мы предлагаем:

- Конкурентоспособные цены и скидки постоянным клиентам.
- Специальные условия для постоянных клиентов.
- Подбор аналогов.
- Поставку компонентов в любых объемах, удовлетворяющих вашим потребностям.
- Приемлемые сроки поставки, возможна ускоренная поставка.
- Доставку товара в любую точку России и стран СНГ.
- Комплексную поставку.
- Работу по проектам и поставку образцов.
- Формирование склада под заказчика.
- Сертификаты соответствия на поставляемую продукцию (по желанию клиента).
- Тестирование поставляемой продукции.
- Поставку компонентов, требующих военную и космическую приемку.
- Входной контроль качества.
- Наличие сертификата ISO.

В составе нашей компании организован Конструкторский отдел, призванный помогать разработчикам, и инженерам.

Конструкторский отдел помогает осуществить:

- Регистрацию проекта у производителя компонентов.
- Техническую поддержку проекта.
- Защиту от снятия компонента с производства.
- Оценку стоимости проекта по компонентам.
- Изготовление тестовой платы монтаж и пусконаладочные работы.



Тел: +7 (812) 336 43 04 (многоканальный)

Email: org@lifeelectronics.ru