

UTS SERIES



# SOURIAU

Waterproof Plastic Connectors  
IP68 and IP69K





## Contents

<b>Overview</b>		<b>Contacts</b>	
Typical Applications .....	06	Description .....	162
Features & Benefits .....	07	Contact Plating Selector Guide .....	163
Range Overview .....	08	Contact Selector Guide .....	164
Layouts .....	10	Packaging .....	164
General Technical Characteristics .....	12	Crimp Contacts .....	165
		#16 Coaxial Contacts .....	167
		PCB Contacts .....	168
		Fiber Optic Contacts .....	170
<b>Connector</b>		<b>Technical Information</b>	
Overmoulded Cable Assembly .....	16	Tooling .....	174
2 contacts .....	20	Crimping Instructions .....	176
2 + ground contacts .....	28	Handle & Interchangeable Heads .....	178
3 contacts .....	36	Extraction Tools .....	179
3 + ground contacts .....	52	Overmoulded Cable Assembly Dimensions .....	179
4 contacts .....	60	Assembly Instructions .....	180
5 contacts .....	72	Mated Connector Lengths .....	184
6 contacts .....	80	Mating Procedure .....	185
6 + ground contacts .....	92	Rated Current & Working Voltage .....	186
7 contacts .....	96	UV Resistance .....	187
8 contacts .....	100	UL94 + UL1977 .....	188
10 contacts .....	112	IEC 61984 & IP Codes Explained .....	191
12 contacts .....	116	IEC 61140 Explained .....	193
14 contacts .....	128	What is NEMA Rating ? .....	194
15 contacts .....	132	Ethernet for the Layman .....	195
18 contacts .....	136		
19 contacts .....	140	<b>Appendices</b>	
23 contacts .....	144	#16 Coaxial Contacts/Cabling Notices .....	200
32 contacts .....	148	Glossary of Terms .....	201
LC (Fiber Optic) .....	152	Discrimination/Keying Methods .....	208
MPO (Fiber Optic) .....	156	Part Number Index .....	209

# UTS SERIES

# Overview

■ Typical Applications .....	06
■ Features & Benefits .....	07
■ Range Overview .....	08
■ Layouts .....	10
■ General Technical Characteristics .....	12

## Typical Applications



Energy - Power



Off-Road



Building Automation & Control



Instrumentation - Measurement



Rail



Stage - Light

## Features & Benefits

- WATER  
PROOF**

### IP68/69K Dynamic Mated & Unmated

Ideal for outdoor and indoor dynamic applications requiring continuous underwater immersion, routine pressure washing and dust protection.

---
  
- UV  
RESISTANT**

### No Degradation Over Time

No mechanical deterioration or important variation in colour after 5 years of exposure in natural environment (equivalent exposure to sun and moisture as per ISO4892) and F1 rated per UL 746C.

---
  
- UL/IEC  
COMPLIANT**

### Qualified & Certified

In accordance with:  
 - UL 1977 - Certificate ECBT2, File number: E169916  
 - CSA C22.2 n°182.3 - Certificat ECBT8, File number: E169916.

---
  
- QUICK  
MATING**

### 1/3 Bayonet Coupling

With only 1/3 twist of the bayonet coupling system, connectors are mated with audible "click" and tactile feel to confirm proper mating. This mating feature eliminates connection uncertainty and reduces time and labor during installation.

---
  
- COST  
SAVINGS**

### Mixed Power & Signal Contacts

Power supply and signal transmission can be combined in a unique interconnect solution to reduce system complexity and minimize component installation cost.

---

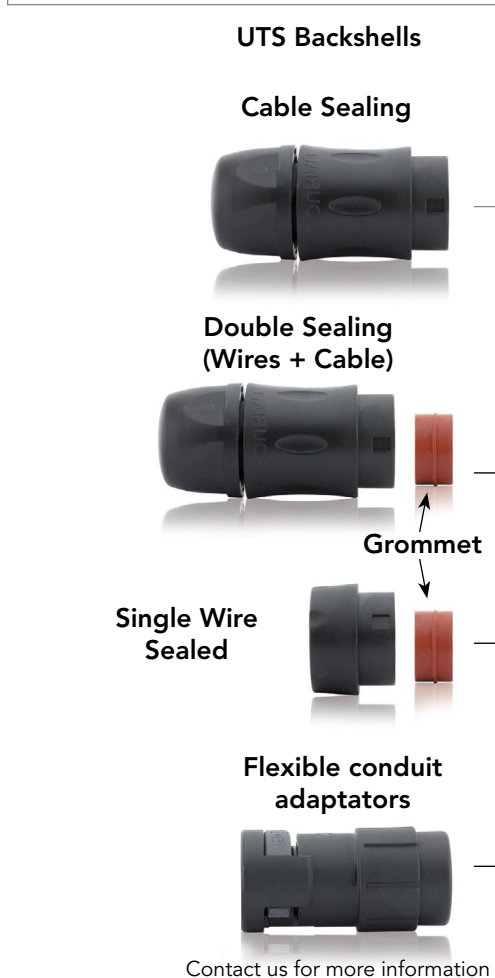
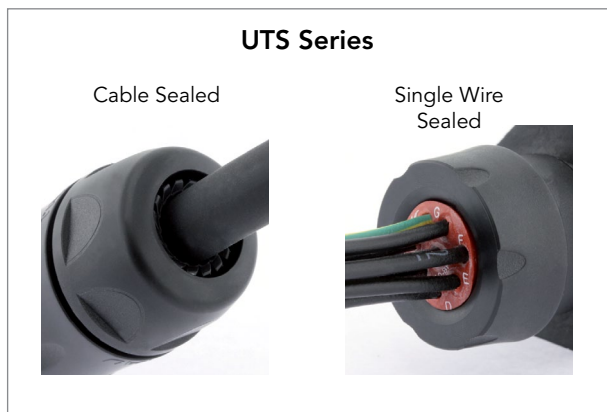

**Contacts Supplied Separately**



**Choice of Crimp Contacts**

- Machined
- Stamped and Formed
- Coaxial

**PCB Contacts**

**Fiber Optic**

**Contacts Loaded  
Screw Termination**

**Contacts Loaded  
Handsolder**

**Plug**



**Overmoulded Cable Assembly**





Overview

UTS Standard Receptacle



**Contacts Supplied Separately**

**Choice of Crimp Contacts**

- Machined
- Stamped and Formed
- Coaxial

**PCB Contacts**

**Fiber Optic**

---

**Contacts Supplied Separately**

**Choice of Crimp Contacts**

- Machined
- Stamped and Formed
- Coaxial

**PCB Contacts**

**Fiber Optic**

---

**Contacts Loaded**

**Screw Termination**

**PCB**

UTS Backshells

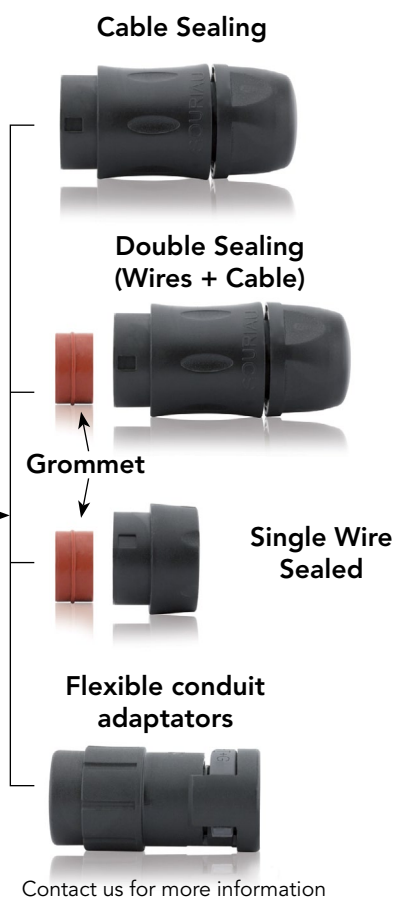

UTS Sealed Unmated Receptacle

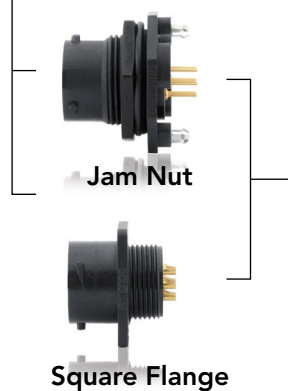

**Contacts Loaded**

**Handsolder**

**PCB**

**UTS PCB Contacts**

Stand-offs to allow cleaning after soldering









Metal hold down clips - to lock the connector easily on the PCB and to release stress on solder joints - suitable for soldering in a metallic hole

Pre-assembled PCB contacts - machined or stamped versions available - different solder tail lengths possible - different plating options

Low profile housing to limit space between panel and PCB

Contact us for more information

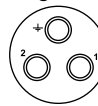
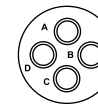
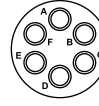
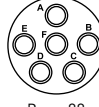
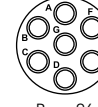
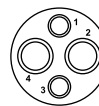
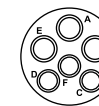
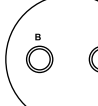
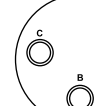
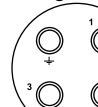
Layouts (Electrical parameter according to IEC)

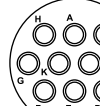
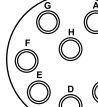
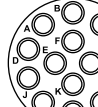
Shell Size	Contact #16 (Ø 1.6mm)	Contact #20 (Ø 1.0mm)	Contact #8 (Ø 3.6mm)	Hybrid & others
8		<p><b>8E2/8D2<sup>(1)</sup></b> 7A 32V 2 contacts  Page 20</p> <p><b>8E3/8D3<sup>(1)</sup></b> 7A 32V 3 contacts  Page 36</p> <p><b>8E3A/8D3A<sup>(1)</sup></b> 7A 50V 3 contacts  Page 40</p> <p><b>8E98/8D98<sup>(1)</sup></b> 7A 50V 3 contacts  Page 40</p> <p><b>8E33/8D33<sup>(1)</sup></b> 7A 50V 3 contacts  Page 44</p> <p><b>8E4/8D4<sup>(1)*</sup></b> 7A 32V 4 contacts  Page 60</p>		
10	<p><b>103</b> 16A 300V 2+ground  Page 28</p> <p><b>104<sup>(3)</sup></b> 13A 150V 4 contacts  Page 68</p>	<p><b>106*</b> <b>10E6<sup>(1)</sup>/10D6</b> 7A 32V 6 contacts  Page 84</p> <p><b>10E98/10D98</b> 7A 50V 6 contacts  Page 88</p> <p><b>10E7<sup>(1)</sup>/10D7</b> 7A 50V 7 contacts  Page 96</p>		<p><b>102W2</b> 25A 150V 4 contacts 2xØ2.4 (#12) 2xØ1.0 (#20)  Page 64</p> <p><b>103W3</b> 5A 32V 6 contacts 3xØ1.6 (#16) 3xØ1.0 (#20)  Page 80</p>
12	<p><b>12E2/12D2</b> 16A 150V 2 contacts  Page 24</p> <p><b>12E3/12D3</b> 16A 150V 3 contacts  Page 48</p> <p><b>124</b> <b>12E4/12D4</b> 16A 300V 3+ground  Page 52</p> <p><b>128<sup>(1) (3)</sup></b> 10A 80V 8 contacts  Page 100</p>	<p><b>1210*</b> <b>12E10/12D10</b> 6A 50V 10 contacts  Page 112</p> <p><b>12E8/12D8</b> 6A 32V 8 contacts  Page 104</p> <p><b>12E14/12D14</b> 5A 32V 14 contacts  Page 128</p>		

1: M12, M16 and M20 threaded receptacle available

2: NPT available

3: Discrete wire grommet option

\* Ethernet compatible: see pages 195 & 196

Contacts #20:  
from AWG 26 to 18  
0.13 to 0.93 mm<sup>2</sup>

Contacts #16:  
from AWG 30 to 14  
0.05 to 2.5 mm<sup>2</sup>

Contacts #12:  
from AWG 22 to 12  
0.13 to 4 mm<sup>2</sup>

Contacts #8:  
from AWG 16 to 8  
1.5 to 10 mm<sup>2</sup>

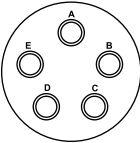
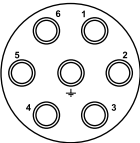
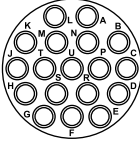
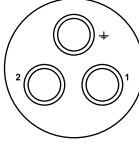
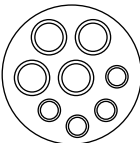
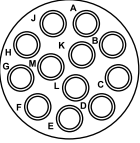
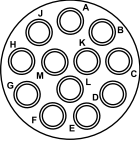
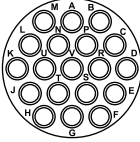
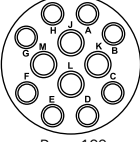
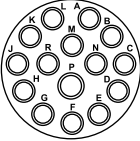
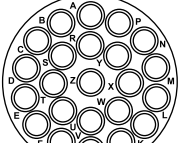
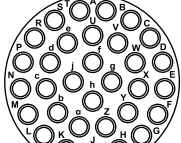
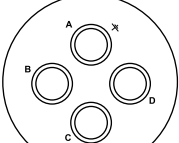
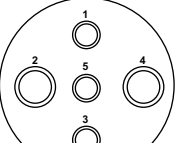
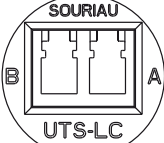
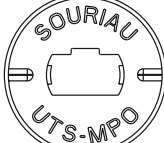
Shell Size	Contact #16 (Ø 1.6mm)	Contact #20 (Ø 1.0mm)	Contact #8 (Ø 3.6mm)	Mixed Power	
14	<p><b>14E5/14D5</b> 16A 150V 5 contacts</p>  <p>Page 72</p>	<p><b>14E7/14D7</b> 16A 300V 6+ground</p>  <p>Page 92</p>	<p><b>14E18/14D18</b> 5A 50V 18 contacts</p>  <p>Page 136</p>	<p><b>142G1<sup>(2)</sup></b> 40A 300V 2+ground</p>  <p>Page 32</p>	<p><b>148</b> 17A 230V 8 contacts 4xØ1.6 (#16)+4xØ2.4 (#12)</p>  <p>Page 108</p>
	<p><b>1412<sup>(3)</sup></b> 10A 63V 12 contacts</p>  <p>Page 116</p>	<p><b>1492<sup>(3)</sup></b> 10A 63V 12 contacts</p>  <p>Page 124</p>	<p><b>1419</b> <b>14E19/14D19</b> 5A 32V 19 contacts</p>  <p>Page 140</p>		<p><b>14E12/14D12</b> 4A 50V 12 contacts 4xØ1.6 (#16)+8xØ1.0 (#20)</p>  <p>Page 120</p>
					<p><b>14E15/14D15</b> 4A 50V 15 contacts 1xØ1.6 (#16)+14xØ1.0 (#20)</p>  <p>Page 132</p>
	18	<p><b>1823</b> 9A 63V 23 contacts</p>  <p>Page 144</p>	<p><b>18E32/18D32</b> 4A 32V 32 contacts</p>  <p>Page 148</p>	<p><b>183G1<sup>(2)</sup></b> 32A 300V 3+ground</p>  <p>Page 56</p>	<p><b>18X2M3<sup>(2)</sup></b> 32A 300V 5 contacts 3xØ1.6 (#16)+2xØ3.6 (#8)</p>  <p>Page 76</p>
				<p><b>LC</b> SOURIAU UTS-LC</p>  <p>Page 152</p> <p><b>MPO</b> SOURIAU UTS-MPO</p>  <p>Page 156</p>	

XXXXXX blue highlighted items: UTS Sealed in Unmated Condition

## General Technical Characteristics



### Materials

- **Body connector + Backshell:** Thermoplastic
- **Insert:**
  - UTS Standard, UTS Single Wire Sealed, UTS Screw Termination Contacts: Thermoplastic
  - UTS Sealed Unmated Handsolder & UTS Sealed Unmated with PC Tails Contacts: Elastomer
- **Nut:** Metal
- **Contacts:** See page 161
- **Halogen free**
- **RoHS compliant & conforms to the Chinese standard SJ/T1166-2006 (Chinese RoHS equivalent)**



### Environmental

- **Operating temperature:** from -40°C to +105°C  
40/100/21 per NFF 61-030
- **Flammability rating:**
  - UL94 V-0 (all UTS except the Sealed Unmated version) see page 180
  - UL94 HB (UTS Sealed Unmated version only) see page 180
  - I2F3 according to NFF 16101 & NFF 16102
- **Salt spray:** per EIA-026A ≥500 hours
- **UV resistant:** No mechanical degradation or important variation of colour after 5 years of exposure in natural environment (equivalence exposure to sun and moisture as per ISO 4892) and F1 rated per UL 746C
- **Sealing:**
  - UTS Standard: IP68/IP69K dynamic (mated)
  - UTS Sealed Unmated version: IP68/IP69K dynamic (unmated)
  - UTS Single Wire Sealed: IP67/69K (up to IP68 with double sealing backshell)
  - UTS Screw Termination Contacts: IP68/IP69K dynamic (mated)

Note: IP68=10 m underwater during 1 week
- **Fluid resistance:**
  - Gas and Oil
  - Mineral oil
  - Acid bath
  - Basic bath

### Electrical

- **In accordance with:**
  - UL 1977: Certificat ECBT2  
File number: E169916
  - CSA C22.2 n°182.3: Certificat ECBT8  
File number: E169916



- Also see pages 10 & 11

### Mechanical

- **Durability:** 250 matings & unmatings per MIL-C-26482
- **Vibration resistance (all UTS versions except UTS Screw Termination contacts):** Sinusoidal vibrations per IEC 60512-4 - from 10 to 2000 Hz
- **Thermal shock:** 5 cycles 30 min. from -40°C to 105°C per MIL-STD-1344 method 1003



# UTS SERIES

## UTS Series

# Connector

■ Overmoulded Cable Assembly .....				16
■ 2 contacts				
	8E2/8D2:	7A	32V.....	20
	12E2/12D2:	16A	150V.....	24
■ 2 contacts + ground				
	103:	16A	300V.....	28
	142G1:	40A	300V.....	32
■ 3 contacts				
	8E3/8D3:	7A	32V.....	36
	8E3A/8E98 - 8D3A/8D98:	7A	50V.....	40
	8E33/8D33:	7A	50V.....	44
	12E3/12D3:	16A	150V.....	48
■ 3 contacts + ground				
	124 - 12E4/12D4:	16A	300V.....	52
	183G1:	32A	300V.....	56
■ 4 contacts				
	8E4/8D4*:	7A	32V.....	60
	102W2:	25A	150V.....	64
	104:	13A	150V.....	68
■ 5 contacts				
	14E5/14D5:	16A	150V.....	72
	18X2M3:	32A	300V.....	76
■ 6 contacts				
	103W3:	5A	32V.....	80
	106* - 10E6/10D6:	7A	32V.....	84
	10E98/10D98:	7A	50V.....	88
■ 6 contacts + ground				
	147 - 14E7/14D7:	16A	300V.....	92
■ 7 contacts				
	10E7/10D7:	7A	50V.....	96
■ 8 contacts				
	128:	10A	80V.....	100
	12E8/12D8:	6A	32V.....	104
	148:	17A	230V.....	108
■ 10 contacts				
	1210* - 12E10/12D10:	6A	50V.....	112
■ 12 contacts				
	1412:	10A	63V.....	116
	14E12/14D12:	4A	50V.....	120
	1492:	10A	63V.....	124
■ 14 contacts				
	12E14/12D14:	5A	32V.....	128
■ 15 contacts				
	14E15/14D15:	4A	50V.....	132
■ 18 contacts				
	14E18/14D18:	5A	50V.....	136
■ 19 contacts				
	1419 - 14E19/14D19:	5A	32V.....	140
■ 23 contacts				
	1823:	9A	63V.....	144
■ 32 contacts				
	1832 - 18E32:	4A	32V.....	148
■ LC .....				152
■ MPO .....				156

Electrical parameters according to IEC

\* Ethernet compatible see pages 195 & 196

## Overmoulded Cable Assembly

SOURIAU has provided connectors in various applications for more than 90 years and used in the most extreme environments. Conscious about the difficulty to finding a quick and a reliable harness manufacturer, we began in-house cable assembly production. It allows customers to reduce the number of suppliers, and to take advantage of the "best in class" quality of the SOURIAU group. Overmoulding is a process that further enhances the sealing properties of the UTS range, especially over many years of use. Overmoulding provides the opportunity to change the cable exit from straight to 90 degrees and avoid stress on the cable terminated to the connector. Also, as the wires are encapsulated inside the molding, a barrier is created which prevents any liquid from entering the equipment through the connector if the cable jacket is breached.



### How to choose the outer jacket material

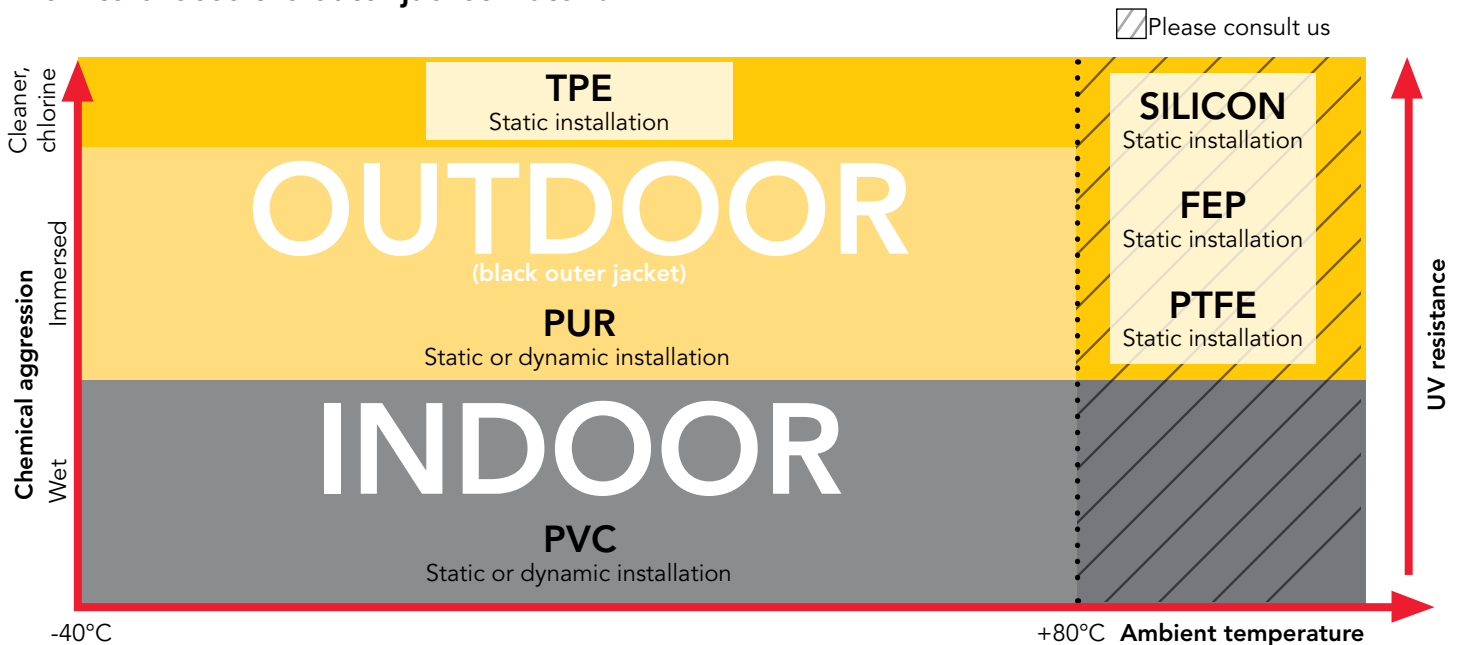



Overmoulding Description

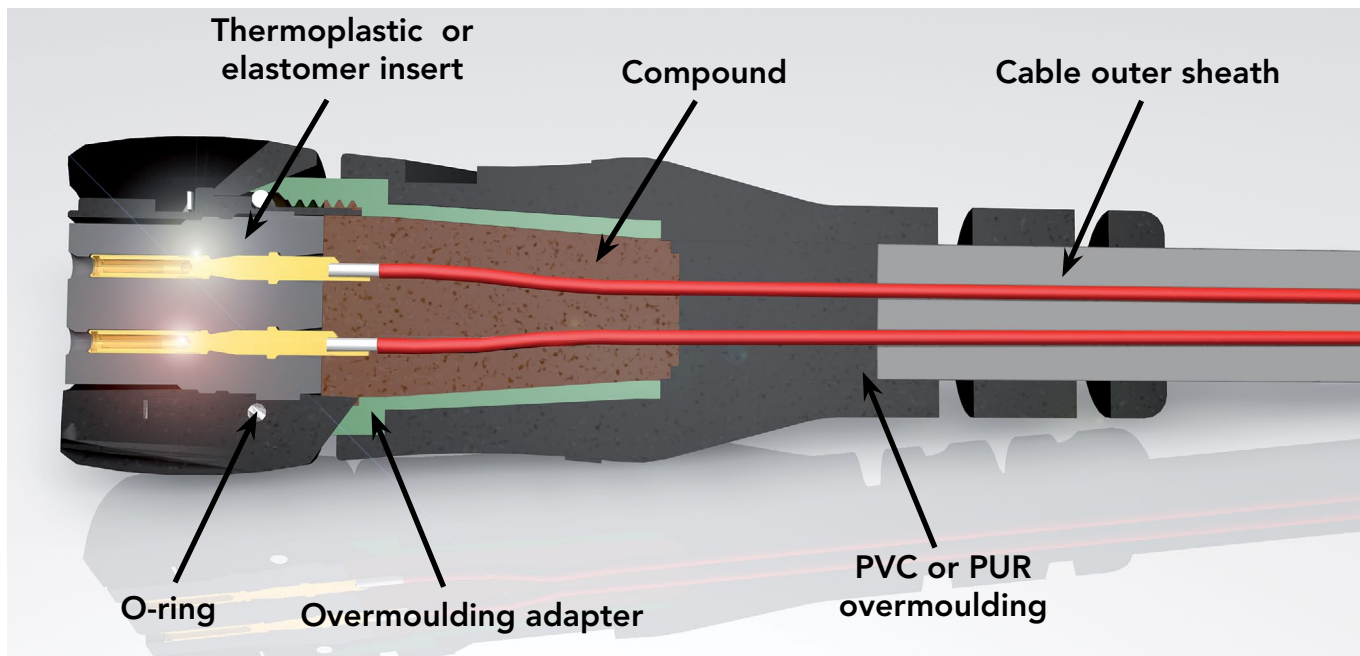

Connector with cable gland backshell

GOOD

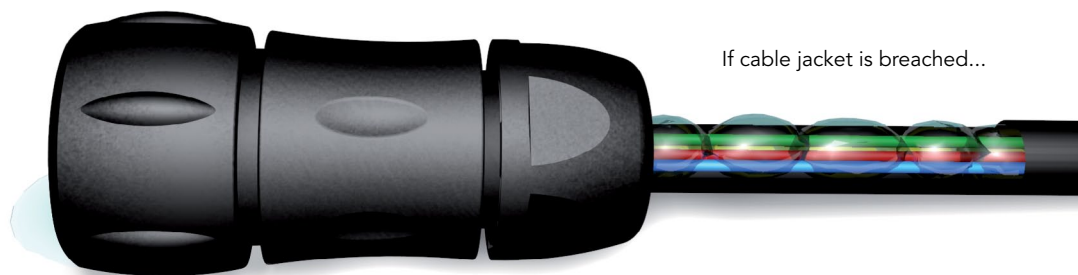

...water ingress unhampered, leading to damage.

Overmoulded connector

BEST



...prevents water ingress via capillary action.

## UTS Waterproof Plastic Overmould



## HAUTS Standard Offering Description

### Cable

- PVC outer sheath (grey color)
- Wire section 1.5 mm<sup>2</sup> for #16 contact
- Wire section 0.5 mm<sup>2</sup> for #20 contact
- 300V
- Unshielded
- Flammability rating IEC (UL1581 Sec.1160)
- Operating temperature: -40°C +70°C

## Overmoulding Specifications

PLATING	SALT SPRAY	TEMPERATURE*	WATERPROOF*	MECHANICAL
No plating	500 H	-40°C up to + 105°C	IP68/IP69K dynamic (mated)	250 matings/unmatings

\* With appropriate cable and overmoulding

## Example of Customized Cable Assemblies



Overmoulding on Curly Cable



Overmoulding with Double Ends



Harness for PCB Connection

To define your customized cable assembly, please consult our technical services.

### Cable Information

**Range of temperature:** Occasional flexing: -5°C up to +70°C  
 Fixed installation: -40°C up to +80°C

**Rated voltage:** U0/U: 300/500V

**Wire section :** Layouts with #16 contact: wire section 1.5 mm<sup>2</sup>  
 Layouts with #20 contact: wire section 0.5 mm<sup>2</sup>

**Harmonized reference:** H05 VV - F XX

### Standardisation of European Cable - DIN VDE 0281/DIN VDE 0282/DIN VDE 0292

#### Harmonized wire coding system

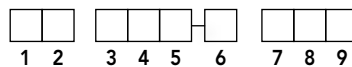

1. Basic type	2. Working voltage	3. Insulating	4. Sheath-cladding material	5. Special features	6. Conductor types	7. Number of conductors	8. Protective conductor	9. Conductor cross-sectional
H: Harmonized Type	03: 300/300V	V: PVC	V: PVC	H: Ribbon cable, separable	U: Single wire		X: Without protective conductor	Area specified in mm <sup>2</sup>
A: National Type	05: 300/500V	R: Rubber	R: Rubber	H2: Ribbon cable non-separable	R: Multi-wire		G: With protective conductor	
	07: 450/750V	S: Silicone Rubber	N: Chloroprene Rubber		K: Fine wire (permanently installed)			
			J: Glass-filament braiding		F: Fine wire (flexible)			
			T: Textile braiding		H: Super fine wire			
					Y: Tinsel strand			

Example: Harmonized type, 300/500V, PVC insulating, PVC sheath-cladding, Fine wire, 3x1.5 cross-sectional: H05VV3x1.5

**8E2/8D2 (Shell size 8, 2x#20)**

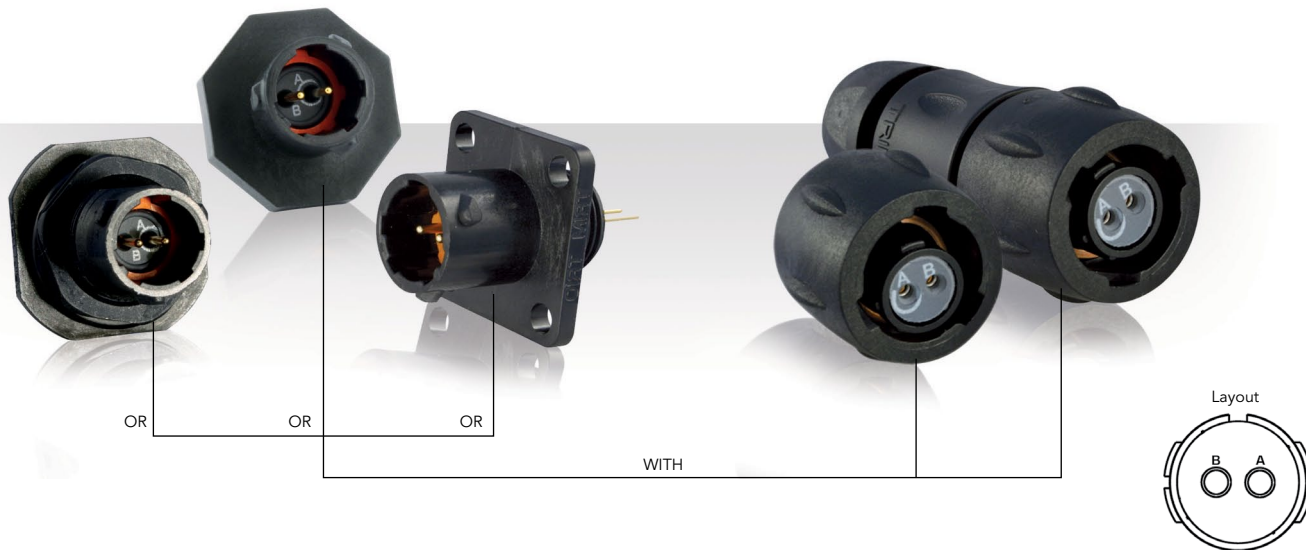

**Connector Part Numbers**

Contact type	Connector type	Backshell	Part number	
			Male insert	Female insert
Hand solder electrical contacts loaded see page 23	Square flange receptacle	Without (Fig.1)	<b>UTS08E2P</b>	<b>UTS08E2S</b>
	Plug	Without (Fig.7)	<b>UTS68E2P</b>	<b>UTS68E2S</b>
		Cable gland (Fig.8)	<b>UTS6JC8E2P</b>	<b>UTS6JC8E2S</b>
	Jam nut receptacle	Without (Fig.4)	<b>UTS78E2P</b>	<b>UTS78E2S</b>
	M12 threaded receptacle	Without (Fig.3)	<b>UTS78E2PM12</b>	<b>UTS78E2SM12</b>
PCB contacts loaded see page 23	Square flange receptacle	Without (Fig.2)	<b>UTS08D2P</b>	<b>UTS08D2S</b>
	Jam nut receptacle with stand off and with hold down clips	Without (Fig.6)	<b>UTS78D2P32</b>	<b>UTS78D2S32</b>
	Jam nut receptacle with stand off and without hold down clip	Without (Fig.5)	<b>UTS78D2P</b>	<b>UTS78D2S</b>
	M12 threaded receptacle	Without (Fig.3)	<b>UTS78D2PM12</b>	<b>UTS78D2SM12</b>

Possibilities of discrimination/keying methods see page 208

Sealed unmated

**Overmoulded Cable Assembly Part Numbers**

Overmoulding type	Connector type	Wire size (mm <sup>2</sup> )	Harmonized cable part number <sup>(1)</sup>	Part number (length: 1m.)*	
				Male plug	Female plug
Straight ending	Plug	0.5	H05 VV - F 2x0.5	<b>HAUTS0V8E2PST100</b>	<b>HAUTS0V8E2SST100</b>
Right angle ending	Plug	0.5	H05 VV - F 2x0.5	<b>HAUTS0V8E2PRA100</b>	<b>HAUTS0V8E2SRA100</b>

(1) Other cable available on demand

\* Other lengths available on demand

8E2/8D2 (Shell size 8, 2x#20)

Dimensions

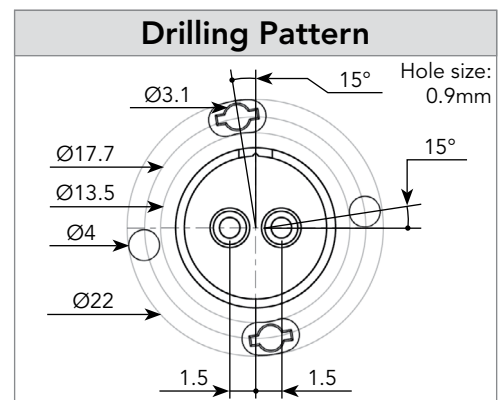
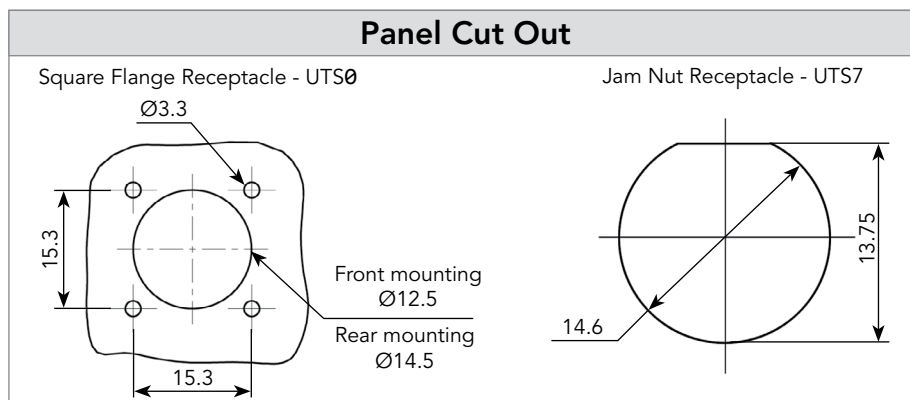
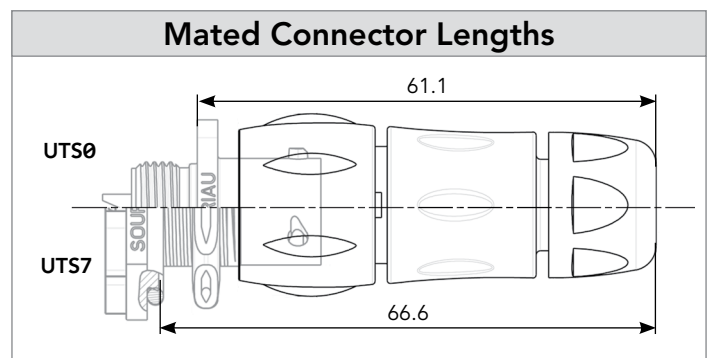
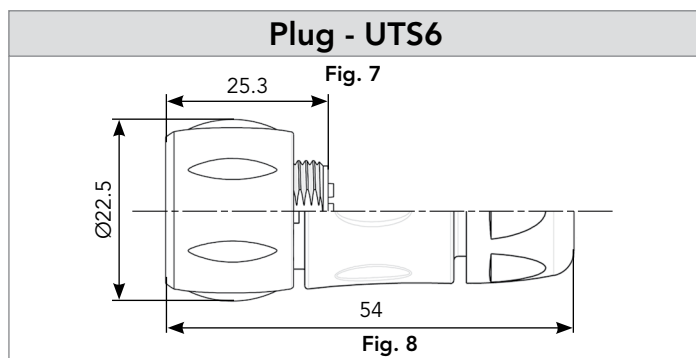
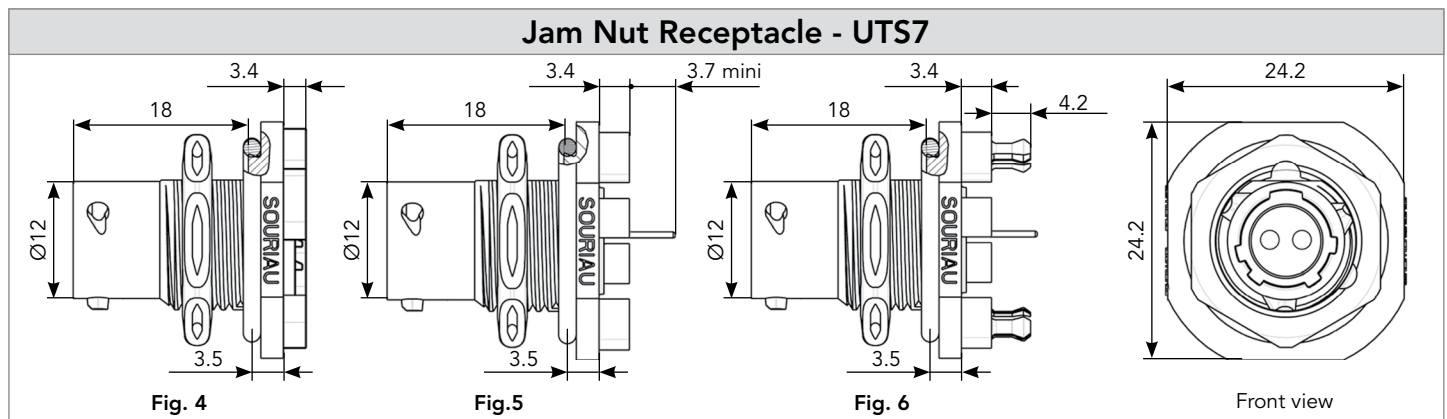
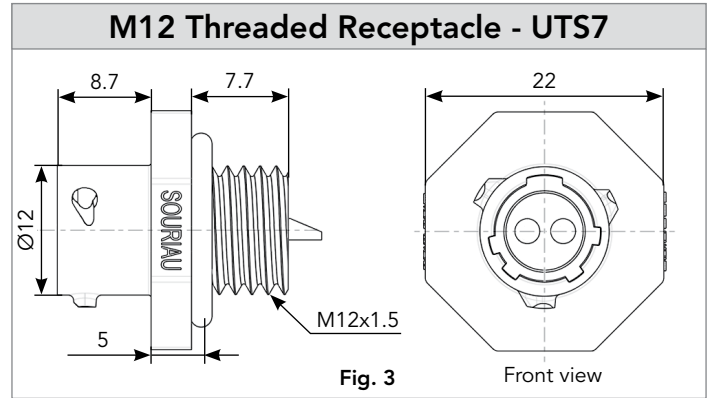
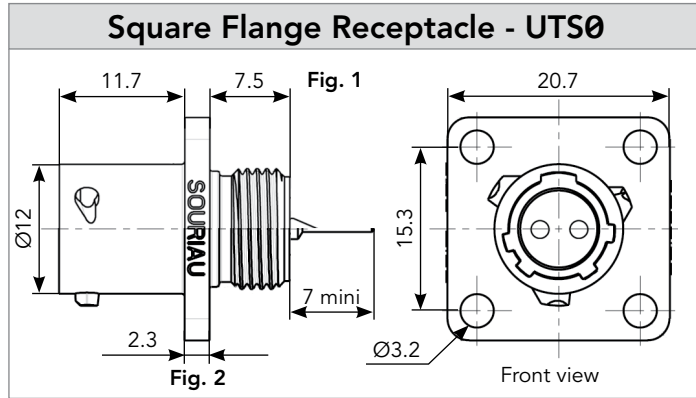

Note: Overmoulded cable assembly dimensions available page 179.

Note: all dimensions are in mm

**8E2/8D2** (Shell size 8, 2x#20)

**Accessories**

**Jam Nut Sealing Caps**



IP68/69K

Part number
UTS8DCG



IP68/69K Metal terminal

Part number
UTS8DCGR

**Square Flange Sealing Cap**



IP68/69K Metal terminal

Part number
UTS8DCGE

**Plug Protective Cap**



IP40

Part number
UTS68C

**Plastic Protective Cap**



Part numbers	
Receptacle cap	Plug cap
85005585A	85005594

**Gasket**



Part numbers
UTFD11B

**Color Coding Rings**

G for Green



Y for Yellow



R for Red



Part numbers	
Receptacles	Plugs
UTS78CCRR	UTS68CCRR
UTS78CCRY	UTS68CCRY
UTS78CCRG	UTS68CCRG

8E2/8D2 (Shell size 8, 2x#20)

Contacts

#20	Contact type	Plating	Cable acceptance (AWG)	Wire stripping length
Hand solder	Loaded in the connector	Min 0.4μ gold over 0.8μ Ni	22 to 18	5 mm
PCB	Machined <sup>(1)</sup>	Min 0.4μ gold over 0.8μ Ni	-	-

(1): For dimensions see page 169

**Electrical Characteristics**

**UL**  
7A 250V UL94 HB

**CSA**  
7A 250V UL94 HB

**IEC**  
7A 32V 1.5kV 3

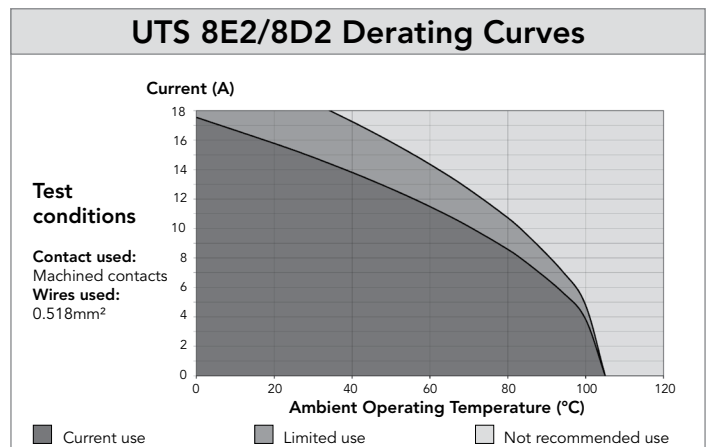

## 12E2/12D2 (Shell size 12, 2x#16)

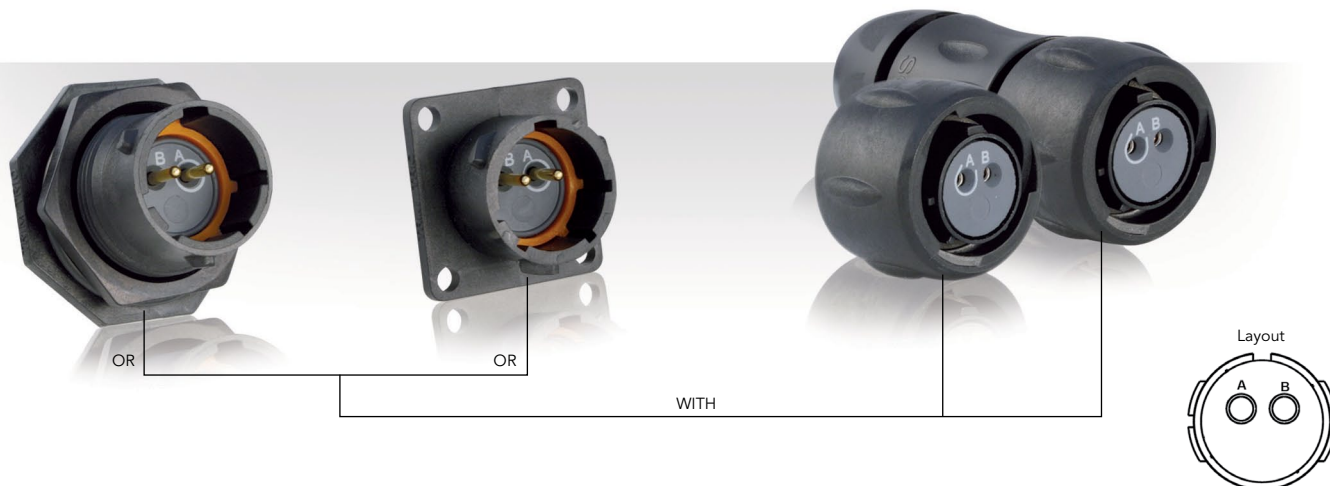

### Connector Part Numbers

Contact type	Connector type	Backshell	Part number	
			Male insert	Female insert
Hand solder electrical contacts loaded see page 27	Square flange receptacle	Without (Fig.1)	<b>UTS012E2P</b>	<b>UTS012E2S</b>
	Plug	Without (Fig.6)	<b>UTS612E2P</b>	<b>UTS612E2S</b>
		Cable gland (Fig.7)	<b>UTS6JC12E2P</b>	<b>UTS6JC12E2S</b>
	Jam nut receptacle	Without (Fig.3)	<b>UTS712E2P</b>	<b>UTS712E2S</b>
PCB contacts loaded see page 27	Square flange receptacle	Without (Fig.2)	<b>UTS012D2P</b>	<b>UTS012D2S</b>
	Jam nut receptacle with stand off and with hold down clips	Without (Fig.5)	<b>UTS712D2P32</b>	<b>UTS712D2S32</b>
	Jam nut receptacle with stand off and without hold down clip	Without (Fig.4)	<b>UTS712D2P</b>	<b>UTS712D2S</b>

Sealed unmatd

### Overmoulded Cable Assembly Part Numbers

Overmoulding type	Connector type	Wire size (mm <sup>2</sup> )	Harmonized cable part number <sup>(1)</sup>	Part number (length: 1m.)*	
				Male plug	Female plug
Straight ending	Plug	1.5	H05 VV - F 2x1.5	<b>HAUTS0V12E2PST100</b>	<b>HAUTS0V12E2SSST100</b>
Right angle ending	Plug	1.5	H05 VV - F 2x1.5	<b>HAUTS0V12E2PRA100</b>	<b>HAUTS0V12E2SRA100</b>

(1) Other cable available on demand

\* Other lengths available on demand



12E2/12D2 (Shell size 12, 2x#16)

Dimensions

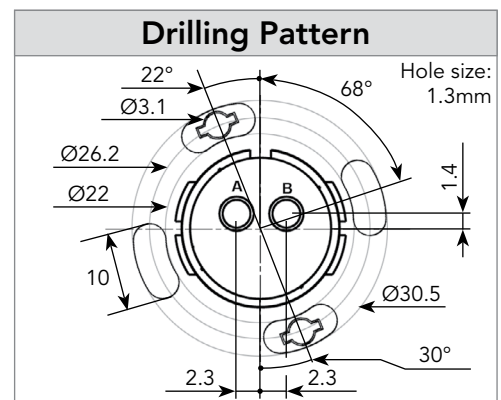
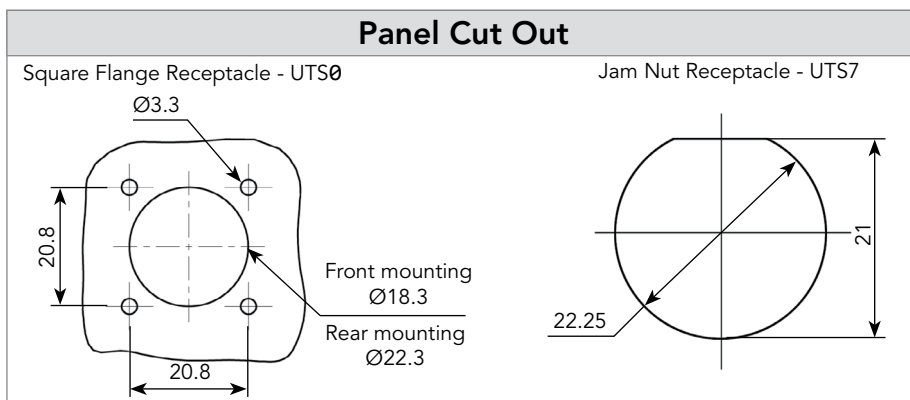
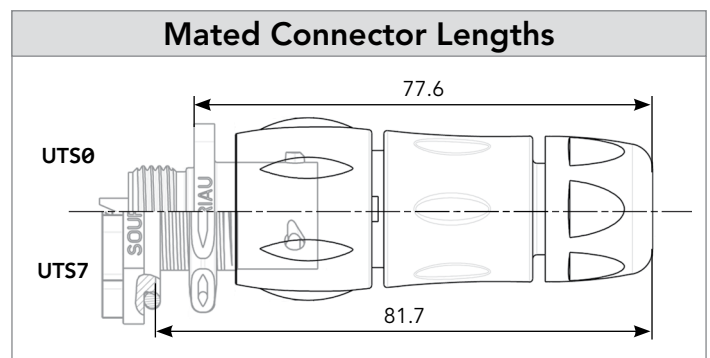
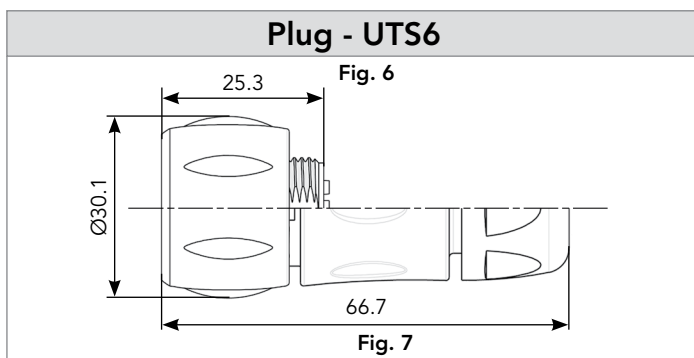
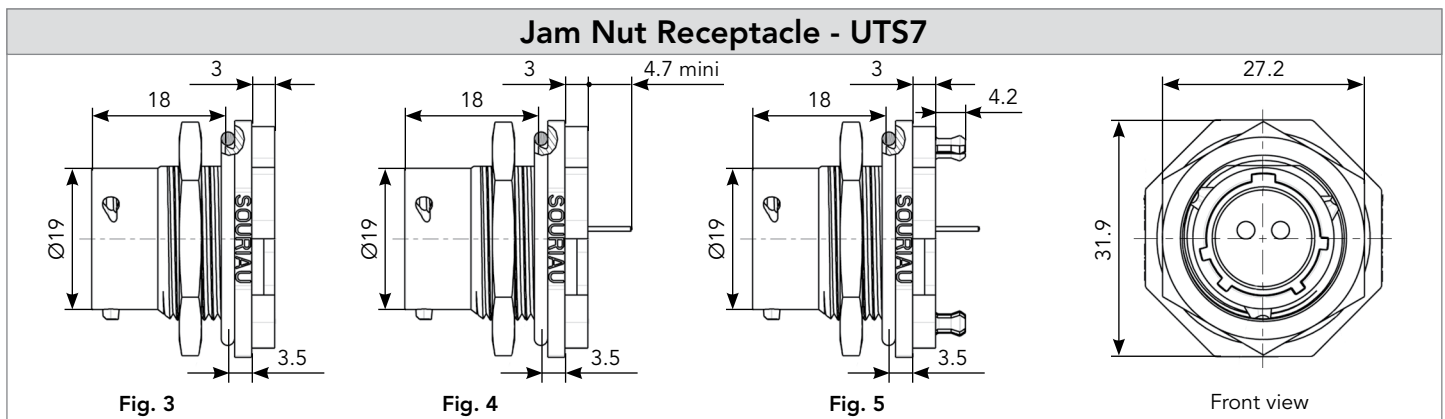
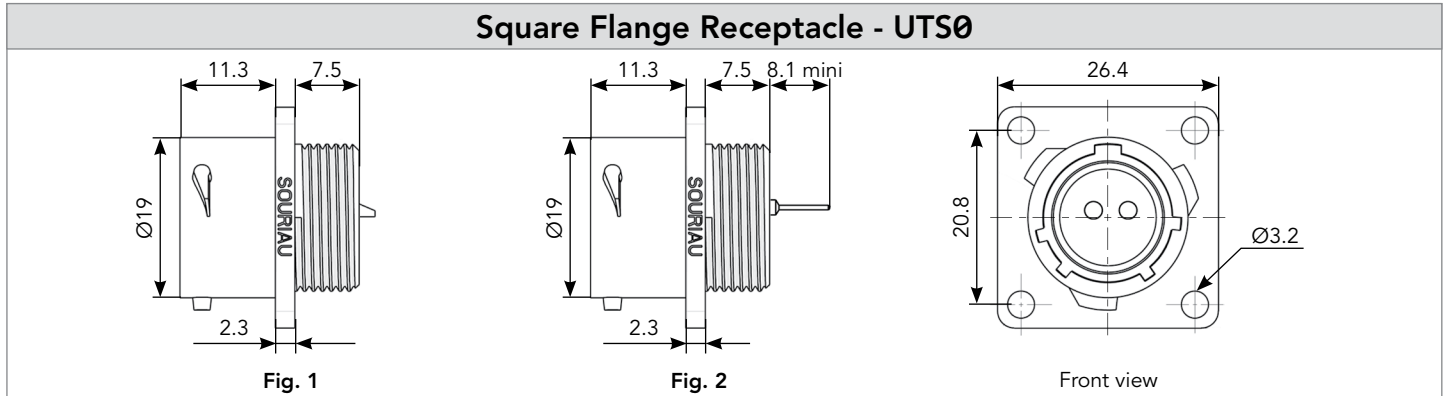

Note: Overmoulded cable assembly dimensions available page 179.

Note: all dimensions are in mm

12E2/12D2 (Shell size 12, 2x#16)

Accessories

**Jam Nut Sealing Caps**



IP68/69K

Part number
UTS12DCG



IP68/69K Metal terminal

Part number
UTS12DCGR

**Square Flange Sealing Cap**



IP68/69K Metal terminal

Part number
UTS12DCGE

**Plug Sealing Cap**



IP68/69K

Part number
UTS612DCG

**Plastic Protective Cap**



Part numbers	
Receptacle cap	Plug cap
85005587A	85005596

**Gasket**



Part numbers
UTFD13B

**Color Coding Rings**

G for Green 

Y for Yellow 

R for Red 

Part numbers	
Receptacles	Plugs
UTS712CCRR	UTS612CCRR
UTS712CCRY	UTS612CCRY
UTS712CCRG	UTS612CCRG

12E2/12D2 (Shell size 12, 2x#16)

Contacts

#16	Contact type	Plating	Cable acceptance (AWG)	Wire stripping length
Hand solder	Loaded in the connector	Min 0.4μ gold over 0.8μ Ni	18 to 14	5 mm
PCB	Machined <sup>(1)</sup>	Min 0.4μ gold over 0.8μ Ni	-	-

(1): For dimensions see page 169

**Electrical Characteristics**

**UL**  
13A 600V UL94 HB

**CSA**  
13A 600V UL94 HB

**IEC**  
16A 150V 2.5kV 3

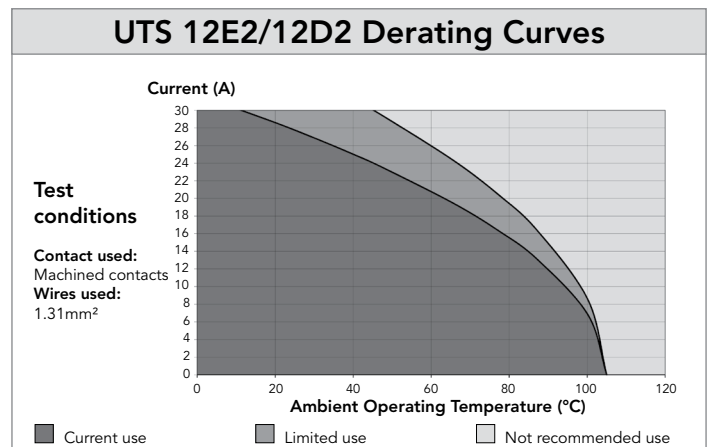

**103** (Shell size 10, 2 + ground, 3x#16)



**Connector Part Numbers**

Contact type	Connector type	Backshell	Part number	
			Male insert	Female insert
Crimp contacts supplied separately see page 31	Free hanging receptacle	Cable gland (Fig. 1)	<b>UTS1JC103P</b>	<b>UTS1JC103S</b>
	Plug	Without (Fig. 2)	<b>UTS6103P</b>	<b>UTS6103S</b>
		Cable gland (Fig. 3)	<b>UTS6JC103P</b>	<b>UTS6JC103S</b>
	Jam nut receptacle	Without (Fig. 4)	<b>UTS7103P</b>	<b>UTS7103S</b>
PCB contacts supplied separately see page 31	Jam nut receptacle	Without (Fig. 4)	<b>UTS7103P</b>	<b>UTS7103S</b>

**Overmoulded Cable Assembly Part Numbers**

Overmoulding type	Connector type	Wire size (mm <sup>2</sup> )	Harmonized cable part number <sup>(1)</sup>	Part number (length: 1m.)*	
				Male plug	Female plug
Straight ending	Plug	1.5	H05 VV - F 3x1.5	<b>HAUTS0V103PST100</b>	<b>HAUTS0V103SST100</b>
Right angle ending	Plug	1.5	H05 VV - F 3x1.5	<b>HAUTS0V103PRA100</b>	<b>HAUTS0V103SRA100</b>

(1) Other cable available on demand

\* Other lengths available on demand

103 (Shell size 10, 2 + ground, 3x#16)

Dimensions

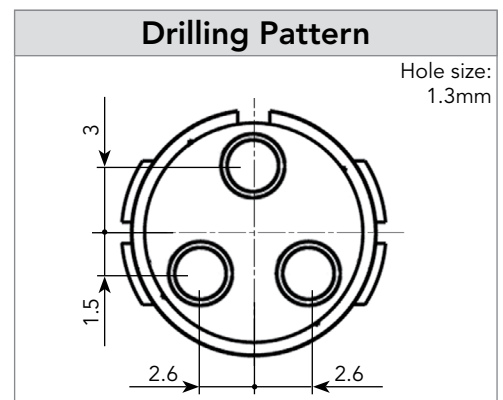
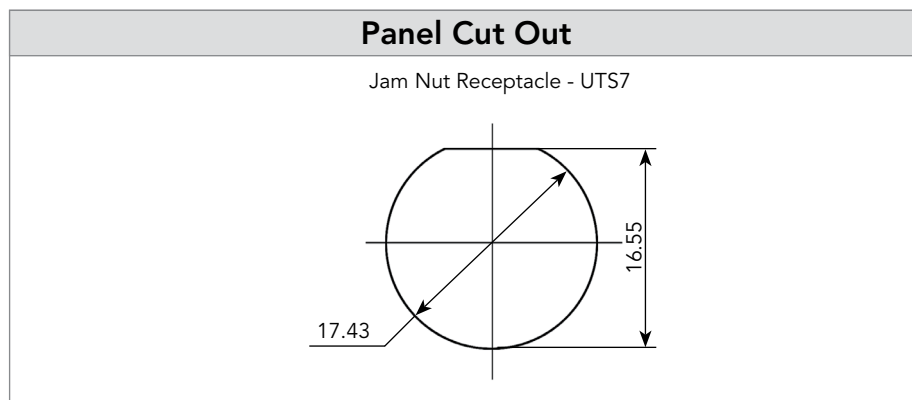
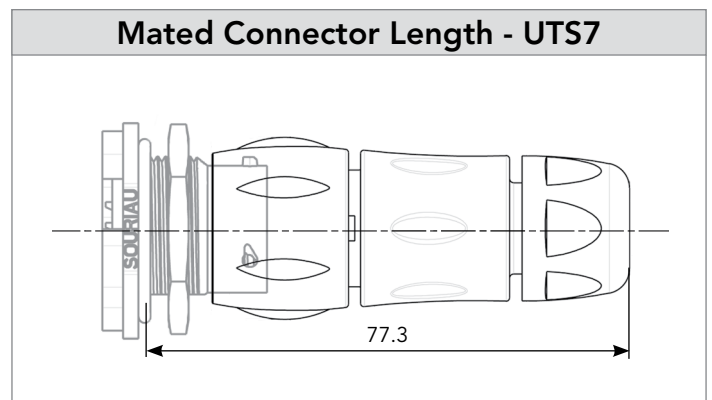
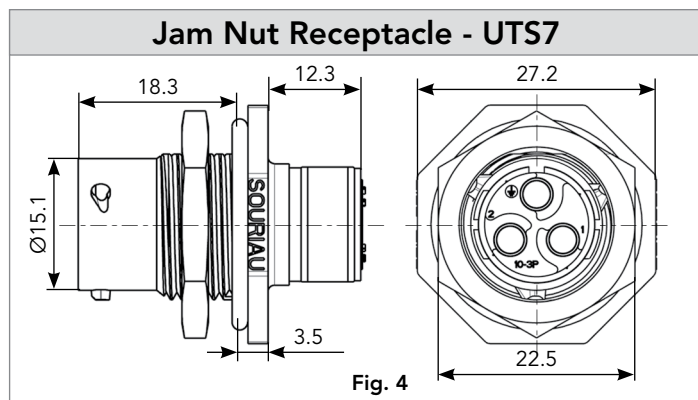
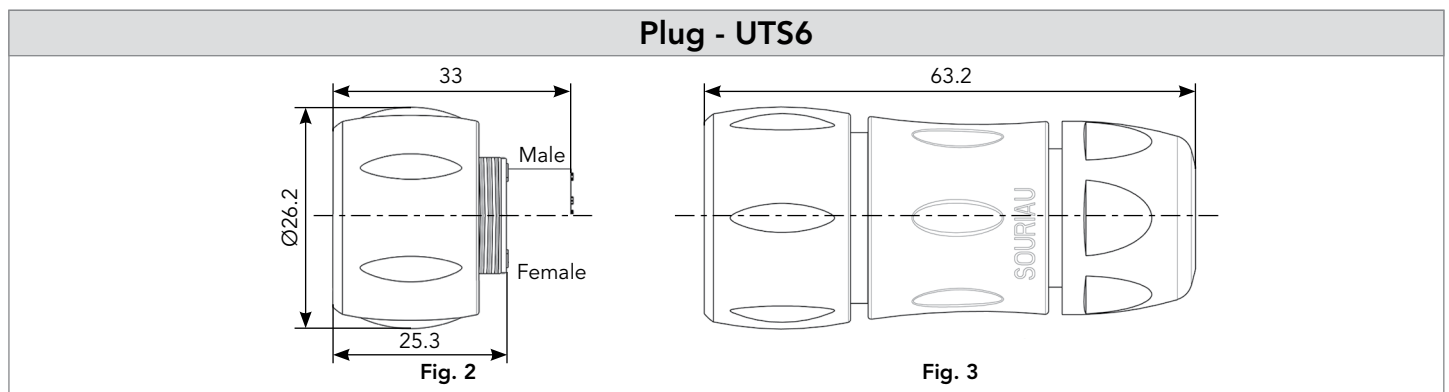
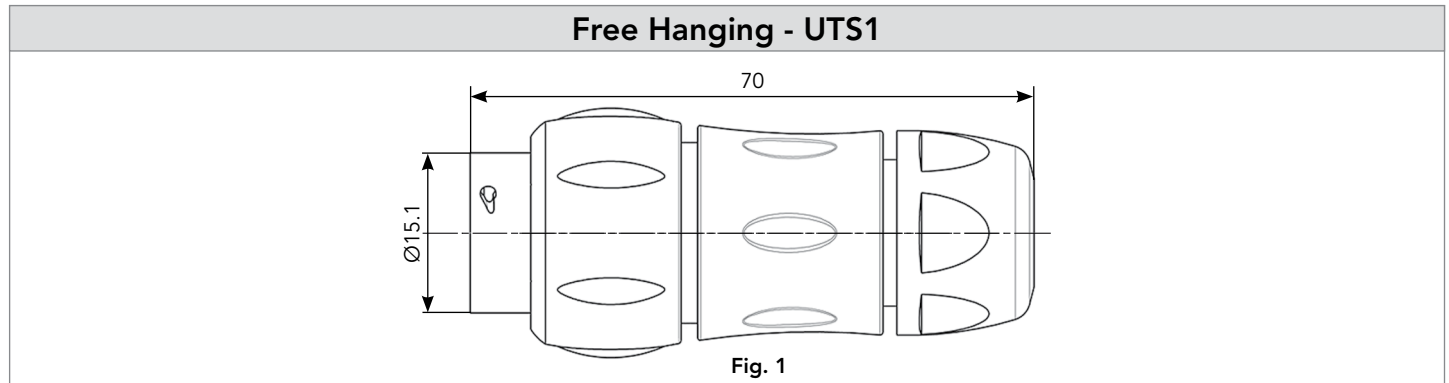

Note: Overmoulded cable assembly dimensions available page 179.

Note: all dimensions are in mm

103 (Shell size 10, 2 + ground, 3x#16)

Accessories and Tooling

### Jam Nut Sealing Caps



IP68/69K

Part number
UTS10DCG



IP68/69K Metal terminal

Part number
UTS10DCGR

### Handle (without Head)



Part number
SHANDLES

### Tool Kit



Part number
TOOLKIT

### Plug Sealing Cap



IP68/69K

Part number
UTS610DCG

### Extraction Tool #16



Part number
RX2025GE1

### Plastic Protective Cap



Part numbers	
Receptacle cap	Plug cap
85005586A	85005595

### Color Coding Rings

G for Green 

Y for Yellow 

R for Red 

Part numbers	
Receptacles	Plugs
UTS710CCRR	UTS610CCRR
UTS710CCRY	UTS610CCRY
UTS710CCRG	UTS610CCRG

### Crimp Tooling (without Shandles)



Contacts	Contact size	Part number of head	
RM/RC 28M1K <sup>(1)</sup>	Standard contacts  #16 Ø 1.6mm	S16RCM20*	
RM/RC 24M9K <sup>(1)</sup>		S16RCM20*	
RM/RC 20M13K <sup>(1)</sup>		S16RCM20*	
RM/RC 20M12K <sup>(1)</sup>		S16RCM20*	
RM/RC 16M23K <sup>(1)</sup>		S16RCM16*	
RM/RC 14M30K <sup>(1)</sup>		S16RCM14*	
SM/SC 24ML1TK6 <sup>(1)</sup>		S16SCM20*	
SM/SC 20ML1TK6 <sup>(1)</sup>		S16SCM20*	
SM/SC 16ML1TK6 <sup>(1)</sup>		S16SCML1*	
SM/SC 14ML1TK6 <sup>(1)</sup>		S16SCML1*	
SM/SC 16ML11TK6 <sup>(1)</sup>		S16SCML11*	
RMDXK10D28K		Coaxial contacts	M10S1J with die set & stop bushing see page 200 to 204
RCDXK1D28K			
RM/RC DX60xxD28K			
RM/RC DXK10D28 + yorK090			
RM/RC DX60xxD28			

(1): Example of plating, for other plating options see page 164  
\* Heads to be used with handle PN: SHANDLES



# 103 (Shell size 10, 2 + ground, 3x#16)

## Contacts



#16	Contact type	AWG	Part number		Max wire Ø	Max insulator Ø
			Male	Female		
Crimp	Machined	30-28	RM28M1K <sup>(1)</sup>	RC28M1K <sup>(1)</sup>	0.55	1.00
		26-24	RM24M9K <sup>(1)</sup>	RC24M9K <sup>(1)</sup>	0.80	1.60
		22-20	RM20M13K <sup>(1)</sup>	RC20M13K <sup>(1)</sup>	1.15	1.80
		22-20	RM20M12K <sup>(1)</sup>	RC20M12K <sup>(1)</sup>	1.15	2.20
		20-16	RM16M23K <sup>(1)</sup>	RC16M23K <sup>(1)</sup>	1.80	3.20
		16-14	RM14M30K <sup>(1)</sup>	RC14M30K <sup>(1)</sup>	2.30	3.20
	Stamped & Formed reeled contacts <small>See note (2) for loose piece</small>	26-24	SM24M1TK6 <sup>(1)(2)</sup>	SC24M1TK6 <sup>(1)(2)</sup>	-	0.90-1.60
		22-20	SM20M1TK6 <sup>(1)(2)</sup>	SC20M1TK6 <sup>(1)(2)</sup>	-	1.20-2.10
		18-16	SM16M1TK6 <sup>(1)(2)</sup>	SC16M1TK6 <sup>(1)(2)</sup>	-	3.20
		18-16	SM16M11TK6 <sup>(1)(2)</sup>	SC16M11TK6 <sup>(1)(2)</sup>	-	3.00
14		SM14M1TK6 <sup>(1)(2)</sup>	SC14M1TK6 <sup>(1)(2)</sup>	-	3.20	
PCB	Machined <sup>(3)</sup>	-	RM20M12E83K <sup>(1)</sup>	RC20M12E84K <sup>(1)</sup>	-	-
Coaxial	Cable Multipiece	see pages 167, 200 to 206	RMDXK10D28	RCDXK1D28	-	-
	Cable Monocrimp		RMDX60xxD28	RCDX60xxD28	-	-
	Twisted pair Multipiece		RMDXK10D28 + york090	RCDXK1D28 + york090	-	-
	Twisted pair Monocrimp		RMDX60xxD28	RCDX60xxD28	-	-
Fiber optic	POF contacts (Plastic Optical Fiber)	-	RMPOF1000	RCPOF1000B	-	-

(1): Example of plating, for other plating see page 164 (2): Loose piece contact available if putting L. Example: SM20ML1TK6 (3): For dimensions see page 168 Note: all dimensions are in mm

### Electrical Characteristics

**UL**  
10A 500V UL94 V-0

**CSA**  
7A 500V UL94 V-0

**IEC**  
16A 300V 4kV 3  
Temperature elevation: 50°C

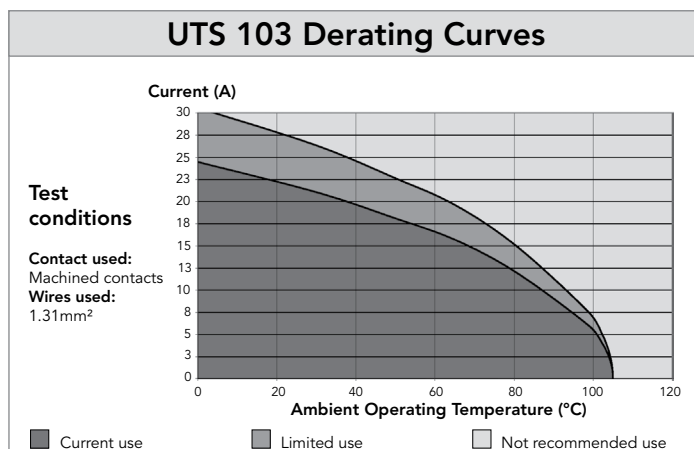

### 142G1 (Shell size 14, 2 + ground, 3x#8)



### Connector Part Numbers

Contact type	Connector type	Backshell	Part number	
			Male insert	Female insert
Crimp contacts supplied separately see page 35	Square flange receptacle	Without (Fig. 1)	<b>UTS0142G1P</b>	-
	Free hanging receptacle	Cable gland (Fig. 6)	<b>UTS1JC142G1P</b>	<b>UTS1JC142G1S</b>
	Plug	Without (Fig. 3)	<b>UTS6142G1P</b>	<b>UTS6142G1S</b>
		Cable gland (Fig. 4)	<b>UTS6JC142G1P</b>	<b>UTS6JC142G1S</b>
	Jam nut receptacle	Without (Fig. 2)	<b>UTS7142G1P</b>	<b>UTS7142G1S</b>
NPT threaded receptacle	Without (Fig. 5)	-	<b>UTS7142G1SNPT</b>	
PCB contacts supplied separately see page 35	Square flange receptacle	Without (Fig. 1)	<b>UTS0142G1P</b>	-
	Jam nut receptacle	Without (Fig. 2)	<b>UTS7142G1P</b>	<b>UTS7142G1S</b>
	NPT threaded receptacle	Without (Fig. 5)	-	<b>UTS7142G1SNPT</b>
	NPT threaded receptacle with nut	Without (Fig. 5)	-	<b>UTS7142G1SNPTNUT</b>

### Overmoulded Cable Assembly Part Numbers

Overmoulding type	Connector type	Wire size (mm <sup>2</sup> )	Harmonized cable part number <sup>(1)</sup>	Part number (length: 1m.)*	
				Male plug	Female plug
Straight ending	Plug	0.5	H05 VV - F 3x0.5	<b>HAUTS0V142G1PST100</b>	<b>HAUTS0V142G1SST100</b>
Right angle ending	Plug	0.5	H05 VV - F 3x0.5	<b>HAUTS0V142G1PRA100</b>	<b>HAUTS0V142G1SRA100</b>

(1) Other cable available on demand

\* Other lengths available on demand



142G1 (Shell size 14, 2 + ground, 3x#8)

Dimensions

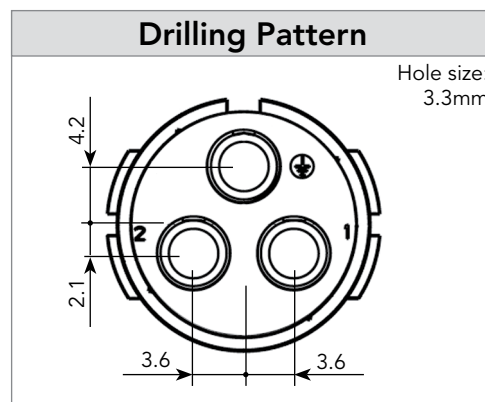
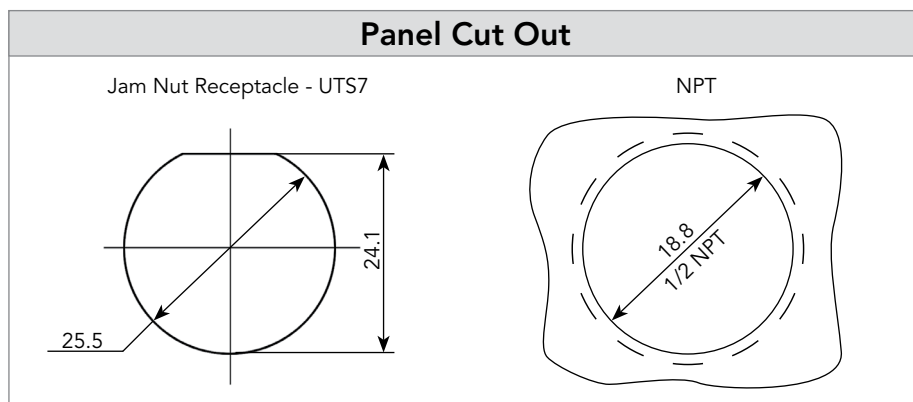
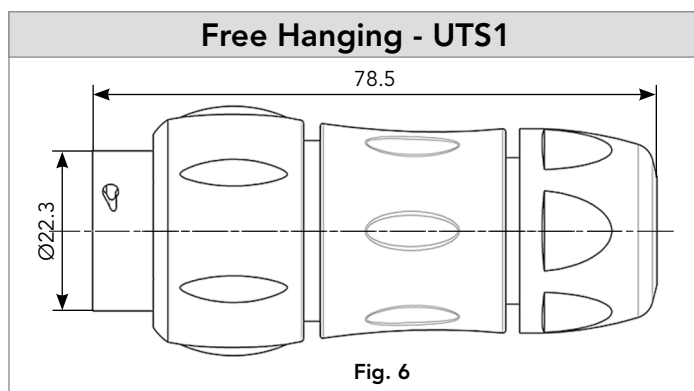
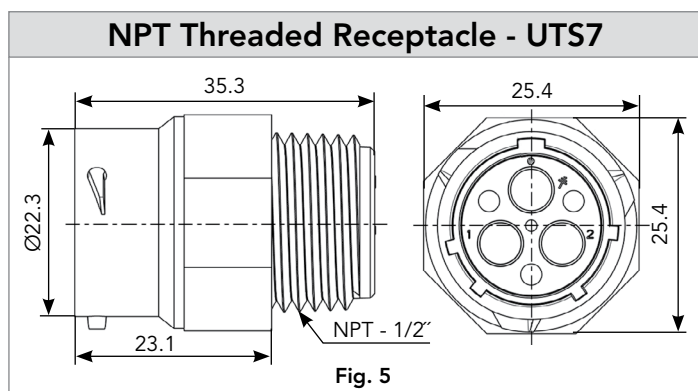
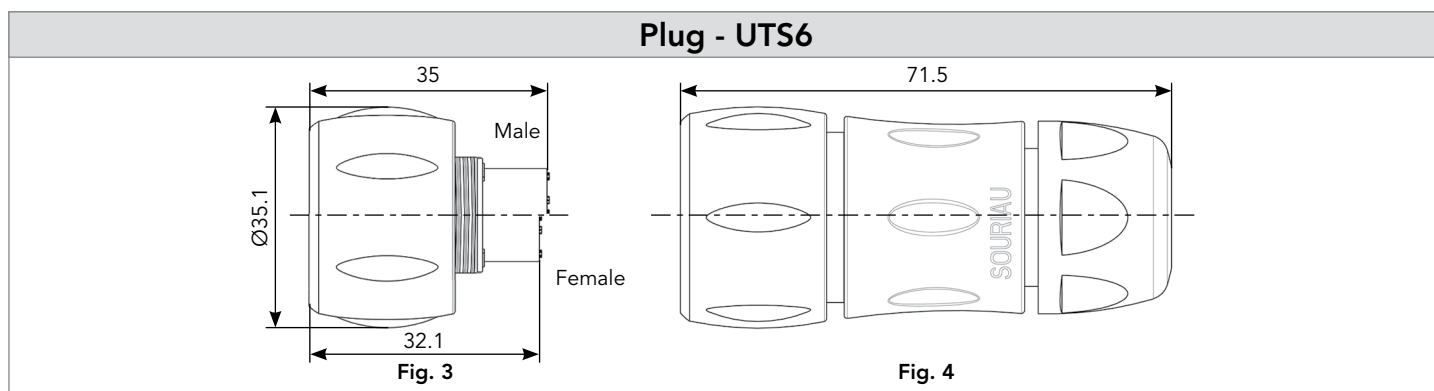
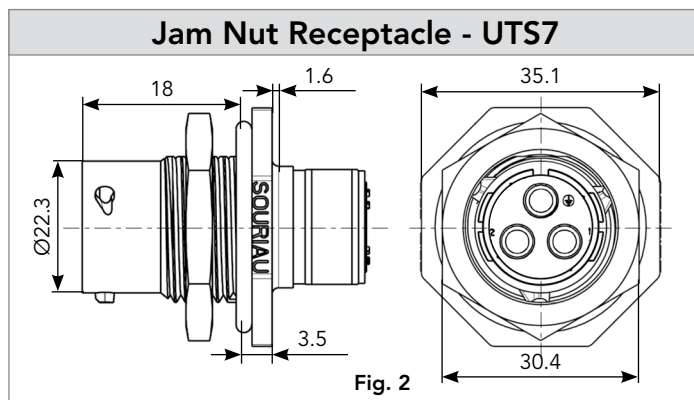
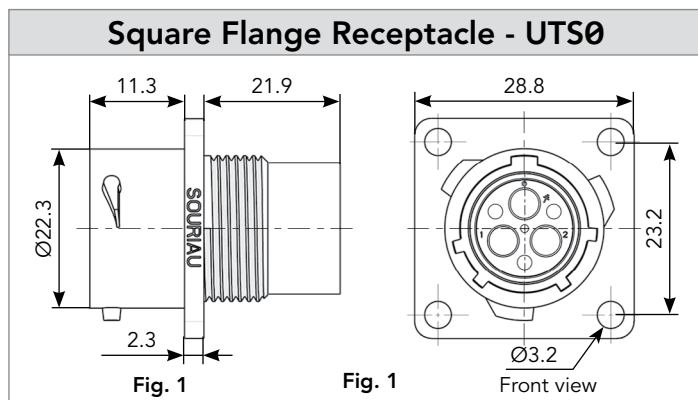

Note: Overmoulded cable assembly dimensions available page 179.

Note: all dimensions are in mm

# 142G1 (Shell size 14, 2 + ground, 3x#8)

## Accessories and Tooling

### Jam Nut or NPT Threaded Receptacle Sealing Caps



IP68/69K

Part number  
UTS14DCG



IP68/69K

Metal terminal

Part number  
UTS14DCGR

### Plug Sealing Cap



IP68/69K

Part number  
UTS614DCG

### Plastic Protective Cap



Part numbers

Receptacle cap	Plug cap
85005588A	85005597

### Gasket



Part numbers

UTFD14B

### Color Coding Rings

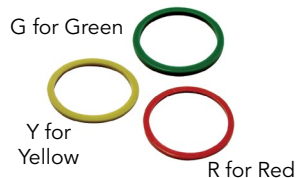

Part numbers	
Receptacles	Plugs
UTS714CCRR	UTS614CCRR
UTS714CCRY	UTS614CCRY
UTS714CCRG	UTS614CCRG

### Hand Tool



Part number  
M317

### Positioner + Locator Setting #8



Part number  
VGE10078A

### Extraction Tool #8



Part number  
51060210936

# 142G1 (Shell size 14, 2 + ground, 3x#8)

## Contacts



#8	Contact type	AWG	Part number		Max wire Ø	Max insulator Ø
			Male	Female		
Crimp	Machined	16	82913601A <sup>(1)</sup>	82913600A <sup>(1)</sup>	1.72 mm	6.5 mm
		14	82913603A <sup>(1)</sup>	82913602A <sup>(1)</sup>	2.22 mm	
		12	82913605A <sup>(1)</sup>	82913604A <sup>(1)</sup>	2.82 mm	
		10	82913607A <sup>(1)</sup>	82913606A <sup>(1)</sup>	3.50 mm	
		8	82913609A <sup>(1)</sup>	82913608A <sup>(1)</sup>	4.35 mm	
PCB	Machined <sup>(2)</sup>	-	82911685NPC <sup>(1)</sup>	82911684NPC <sup>(1)</sup>	-	-

(1): Example of plating, for other plating see page 164  
 (2): For dimensions see page 168

### Electrical Characteristics

**UL**  
44A 600V UL94 V-0

**CSA**  
30A 600V UL94 V-0

**IEC**  
40A 300V 4kV 3

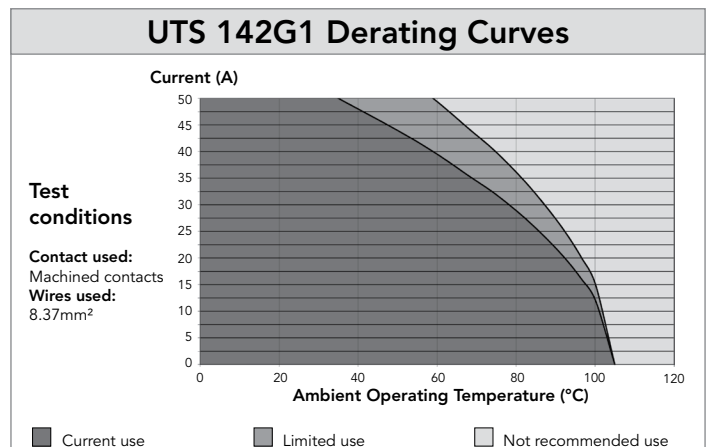

### 8E3/8D3 (Shell size 8, 3x#20)

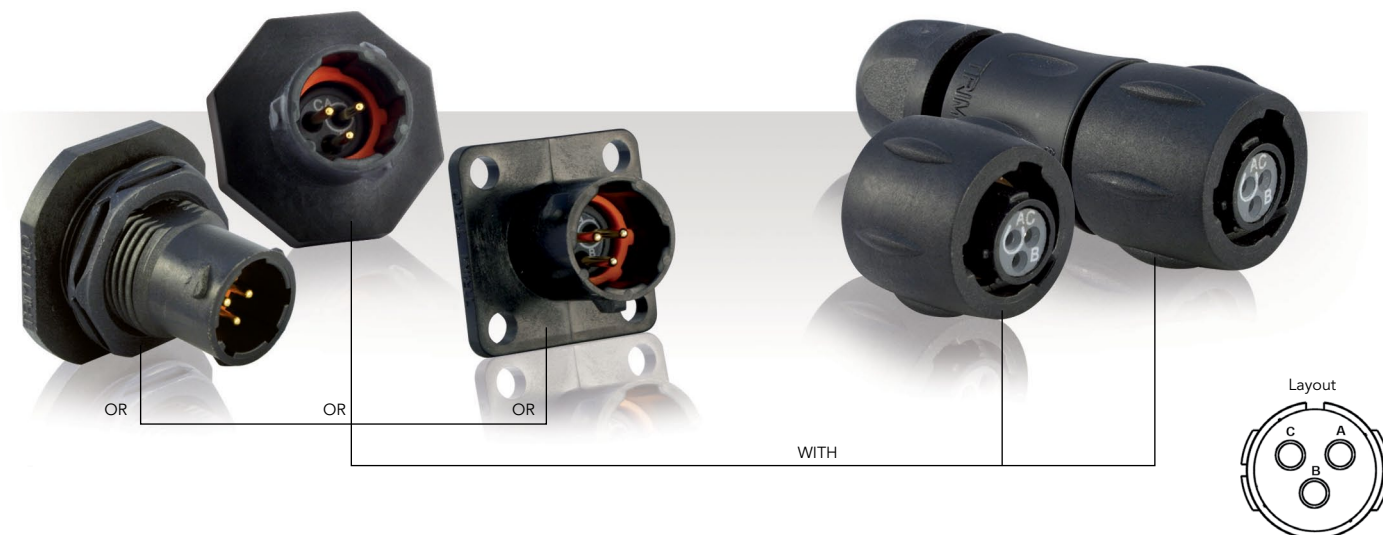

### Connector Part Numbers

Contact type	Connector type	Backshell	Part number	
			Male insert	Female insert
Hand solder electrical contacts loaded see page 39	Square flange receptacle	Without (Fig. 1)	<b>UTS08E3P</b>	<b>UTS08E3S</b>
	Plug	Without (Fig. 7)	<b>UTS68E3P</b>	<b>UTS68E3S</b>
		Cable gland (Fig. 8)	<b>UTS6JC8E3P</b>	<b>UTS6JC8E3S</b>
	Jam nut receptacle	Without (Fig. 4)	<b>UTS78E3P</b>	<b>UTS78E3S</b>
	M12 threaded receptacle	Without (Fig.3)	<b>UTS78E3PM12</b>	<b>UTS78E3SM12</b>
PCB contacts loaded see page 39	Square flange receptacle	Without (Fig. 2)	<b>UTS08D3P</b>	<b>UTS08D3S</b>
	Jam nut receptacle with stand off and with hold down clips	Without (Fig. 6)	<b>UTS78D3P32</b>	<b>UTS78D3S32</b>
	Jam nut receptacle with stand off and without hold down clip	Without (Fig. 5)	<b>UTS78D3P</b>	<b>UTS78D3S</b>
	M12 threaded receptacle	Without (Fig.3)	<b>UTS78D3PM12</b>	<b>UTS78D3SM12</b>

Possibilities of discrimination/keying methods see page 208

Sealed unmatred

### Overmoulded Cable Assembly Part Numbers

Overmoulding type	Connector type	Wire size (mm <sup>2</sup> )	Harmonized cable part number <sup>(1)</sup>	Part number (length: 1m.)*	
				Male plug	Female plug
Straight ending	Plug	0.5	H05 VV - F 3x0.5	<b>HAUTS0V8E3PST100</b>	<b>HAUTS0V8E3SST100</b>
Right angle ending	Plug	0.5	H05 VV - F 3x0.5	<b>HAUTS0V8E3PRA100</b>	<b>HAUTS0V8E3SRA100</b>

(1) Other cable available on demand

\* Other lengths available on demand

8E3/8D3 (Shell size 8, 3x#20)

Dimensions

3

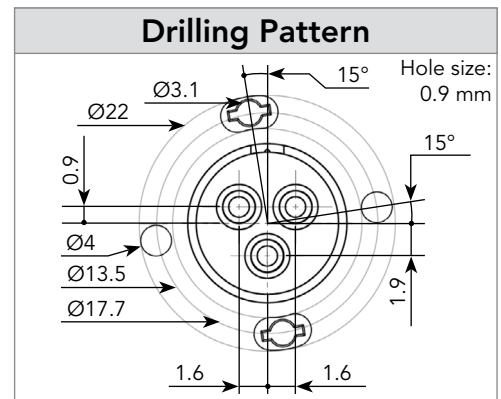
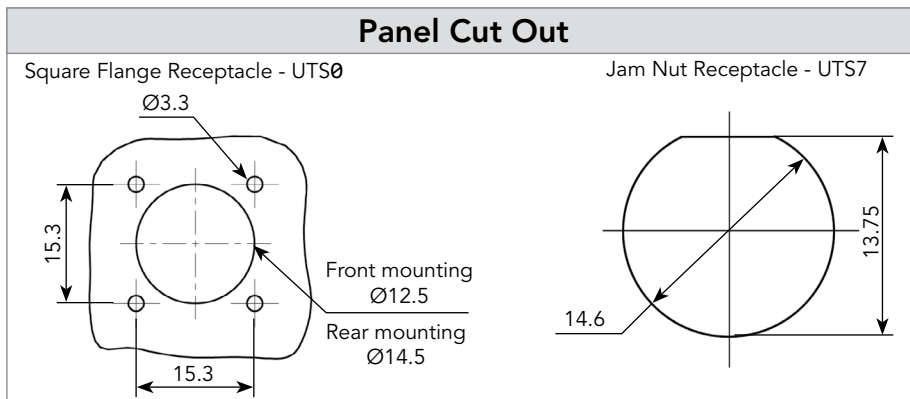
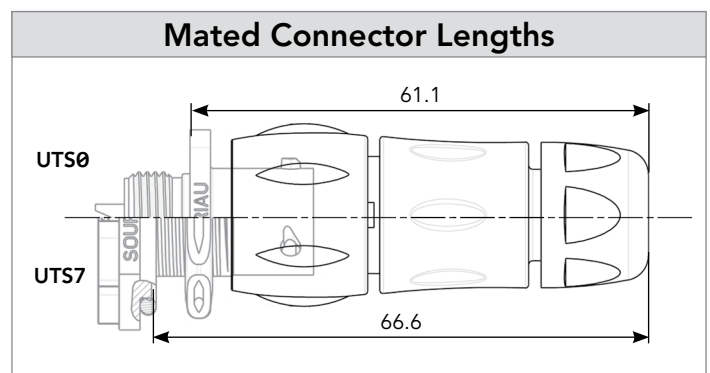
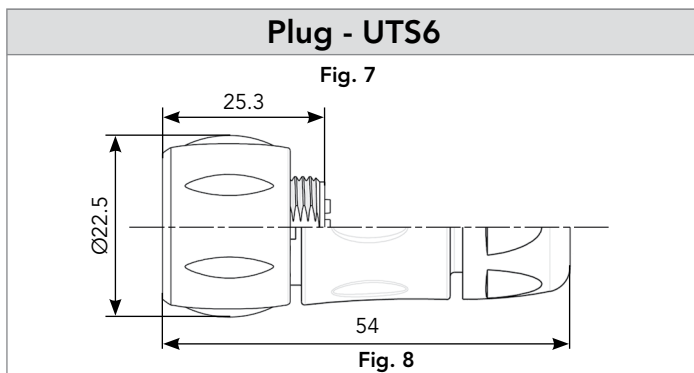
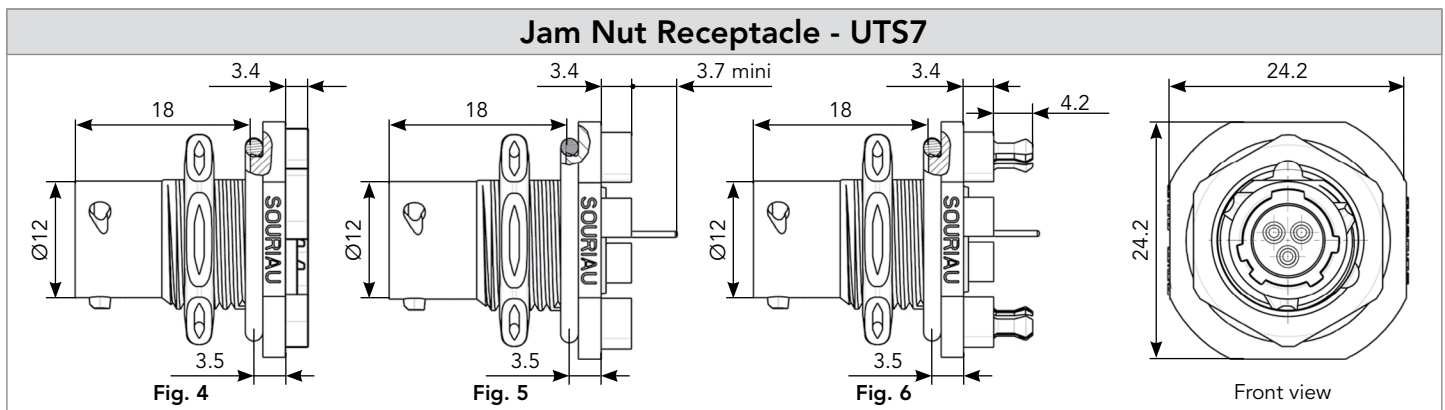
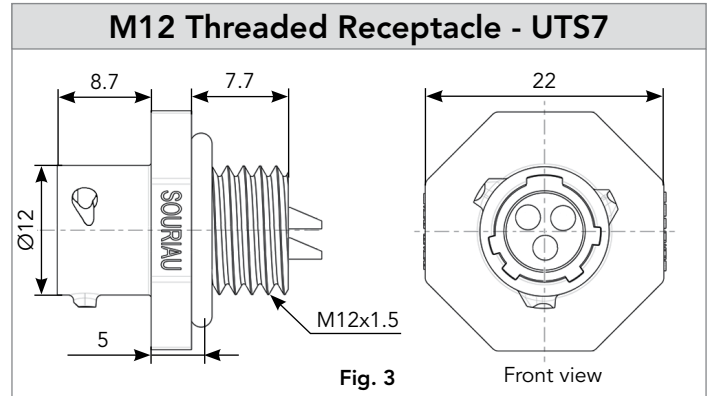
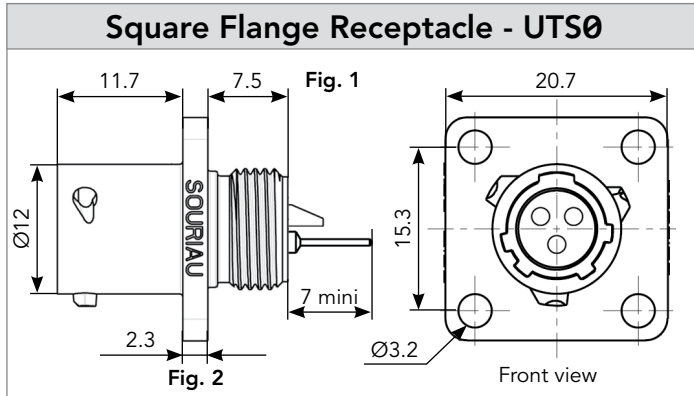

Note: Overmoulded cable assembly dimensions available page 179.

Note: all dimensions are in mm

**8E3/8D3** (Shell size 8, 3x#20)

**Accessories**

**Jam Nut Sealing Caps**



IP68/69K

Part number
UTS8DCG



IP68/69K Metal terminal

Part number
UTS8DCGR

**Square Flange Sealing Cap**



IP68/69K Metal terminal

Part number
UTS8DCGE

**Plug Protective Cap**



IP40

Part number
UTS68C

**Plastic Protective Cap**



Part numbers	
Receptacle cap	Plug cap
85005585A	85005594

**Gasket**



Part numbers
UTFD11B

**Color Coding Rings**

G for Green



Y for Yellow



R for Red



Part numbers	
Receptacles	Plugs
UTS78CCRR	UTS68CCRR
UTS78CCRY	UTS68CCRY
UTS78CCRG	UTS68CCRG

8E3/8D3 (Shell size 8, 3x#20)

Contacts

#20	Contact type	Plating	Cable acceptance (AWG)	Wire stripping length
Hand solder	Loaded in the connector	Min 0.4μ gold over 0.8μ Ni	22 to 18	5 mm
PCB	Machined <sup>(1)</sup>	Min 0.4μ gold over 0.8μ Ni	-	-

(1): For dimensions see page 169

3

Electrical Characteristics
<p><b>UL</b> 7A 250V UL94 HB</p> <p><b>CSA</b> 7A 250V UL94 HB</p> <p><b>IEC</b> 7A 32V 1.5kV 3</p>

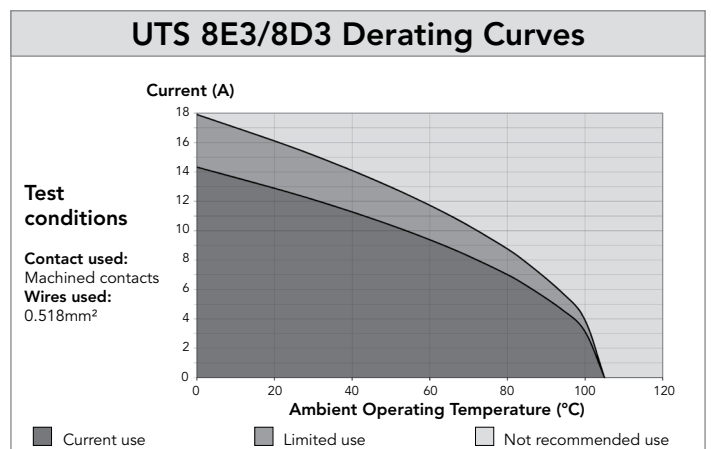

## 8E3A/8E98 - 8D3A/8D98 (Shell size 8, 3x#20)

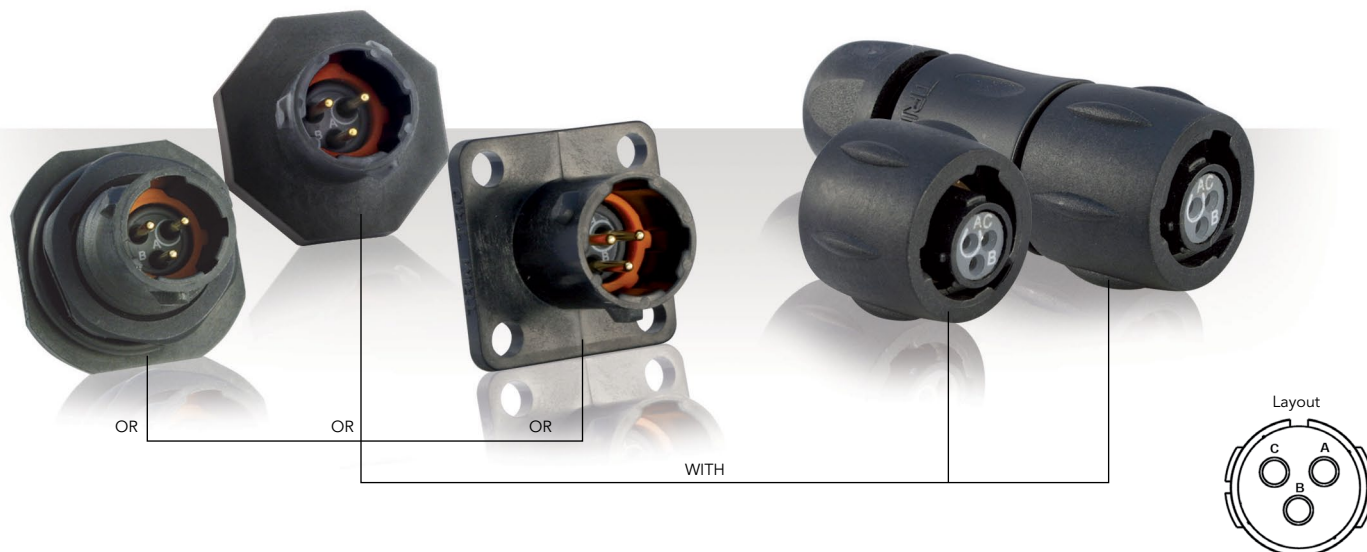

### Connector Part Numbers

Contact type	Connector type	Backshell	Part number	
			Male insert	Female insert
Hand solder electrical contacts loaded see page 43	Square flange receptacle	Without (Fig. 1)	UTS08E3AP	UTS08E3AS
		Without (Fig. 7)	UTS08E98P	UTS08E98S
	Plug	Without (Fig. 8)	UTS68E3AP	UTS68E3AS
			UTS68E98P	UTS68E98S
			UTS6JC8E3AP	UTS6JC8E3AS
	Jam nut receptacle	Without (Fig. 4)	UTS6JC8E98P	UTS6JC8E98S
			UTS78E3AP	UTS78E3AS
	M12 threaded receptacle	Without (Fig. 3)	UTS78E98P	UTS78E98S
			UTS78E3APM12	UTS78E3ASM12
			UTS78E98PM12	UTS78E98SM12
Square flange receptacle		Without (Fig. 2)	UTS78E3APM12	UTS78E3ASM12
			UTS78E98PM12	UTS78E98SM12
PCB contacts loaded see page 43		Jam nut receptacle with stand off and with hold down clips	Without (Fig. 6)	UTS08D3AP
			UTS08D98P	UTS08D98S
	Jam nut receptacle with stand off and without hold down clip	Without (Fig. 5)	UTS78D3AP32	UTS78D3AS32
			UTS78D98P32	UTS78D98S32
M12 threaded receptacle	Without (Fig. 3)	UTS78D3AP	UTS78D3AS	
		UTS78D98P	UTS78D98S	
		UTS78D3APM12	UTS78D3ASM12	
		UTS78D98PM12	UTS78D98SM12	

Possibilities of discrimination/keying methods see page 208

Sealed unmatred

### Overmoulded Cable Assembly Part Numbers

Overmoulding type	Connector type	Wire size (mm <sup>2</sup> )	Harmonized cable part number <sup>(1)</sup>	Part number (length: 1m.)*	
				Male plug	Female plug
Straight ending	Plug	0.5	H05 VV - F 3x0.5	HAUTS0V8E3APST100	HAUTS0V8E3ASST100
Right angle ending	Plug	0.5	H05 VV - F 3x0.5	HAUTS0V8E3APRA100	HAUTS0V8E3ASRA100

(1) Other cable available on demand

\* Other lengths available on demand



8E3A/8E98 - 8D3A/8D98 (Shell size 8, 3x#20)

Dimensions

3

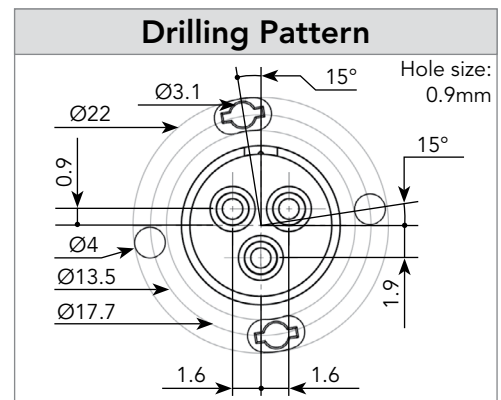
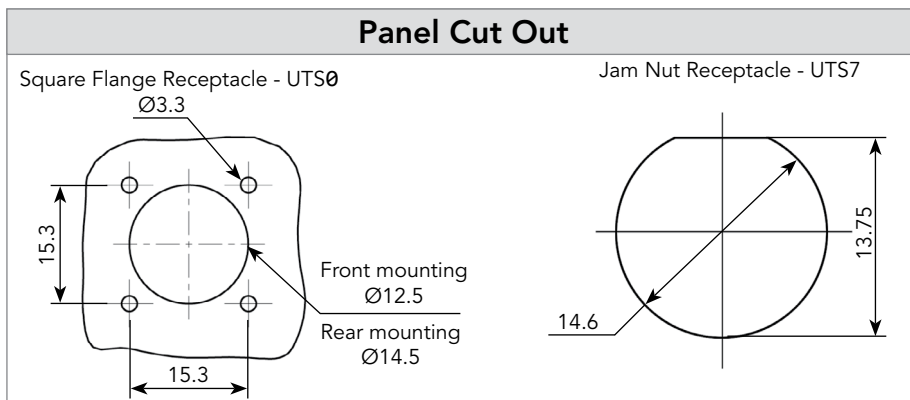
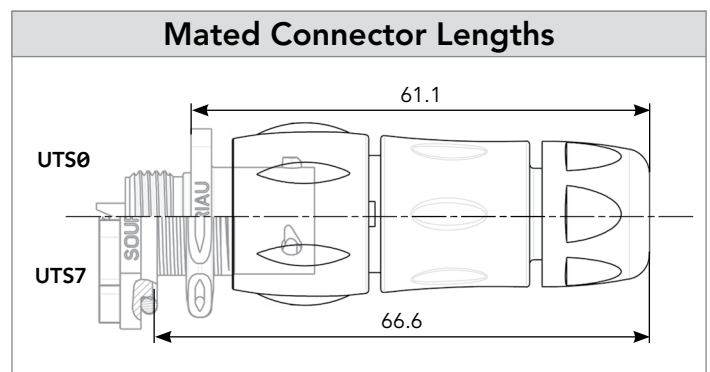
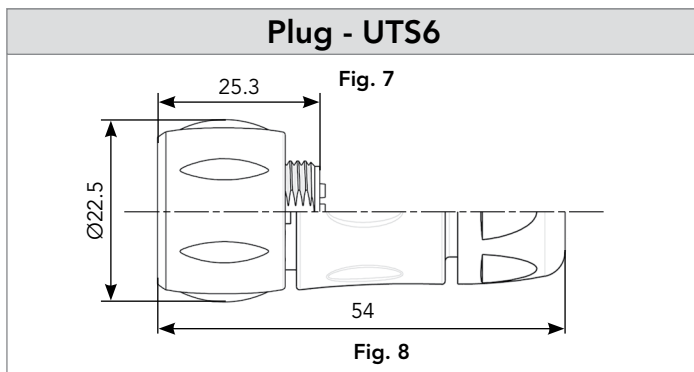
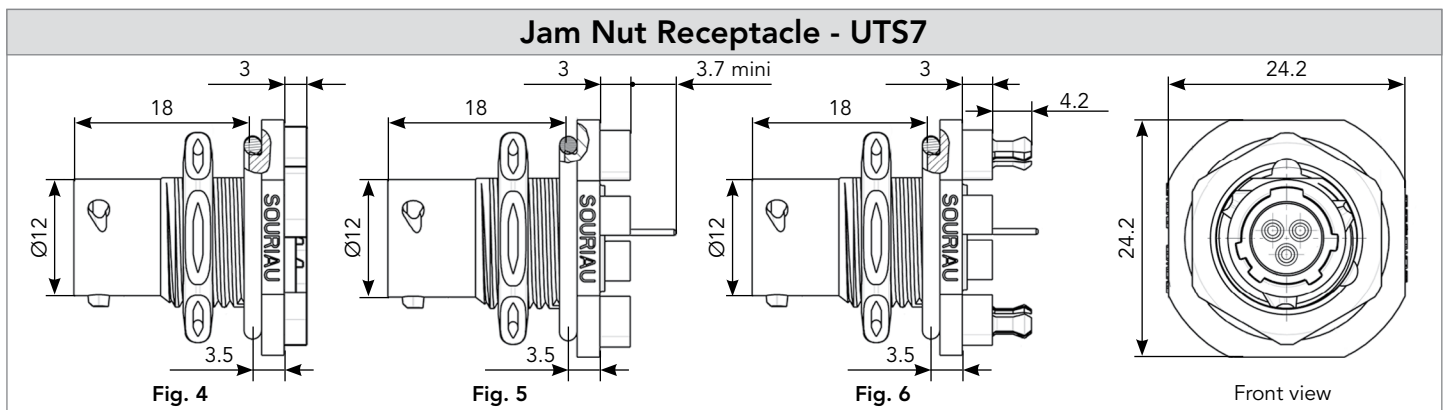
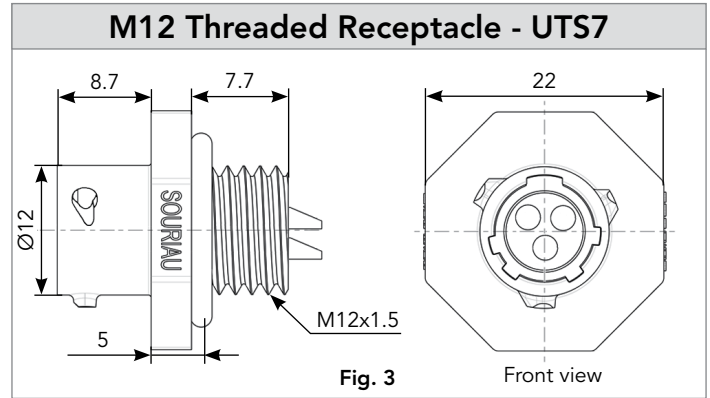
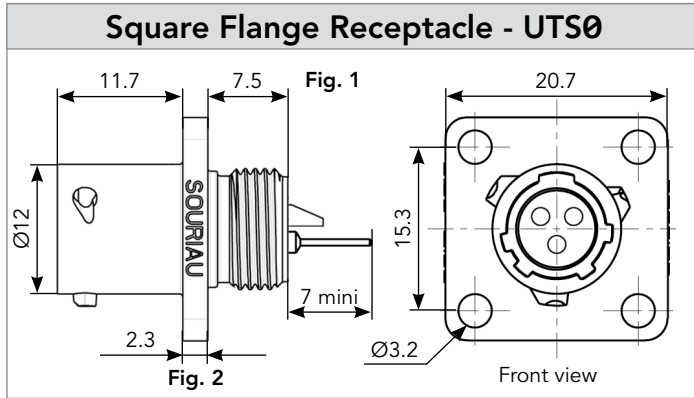

Note: Overmoulded cable assembly dimensions available page 179.

Note: all dimensions are in mm

**8E3A/8E98 - 8D3A/8D98** (Shell size 8, 3x#20)

**Accessories**

**Jam Nut Sealing Caps**



IP68/69K

Part number
UTS8DCG



IP68/69K Metal terminal

Part number
UTS8DCGR

**Square Flange Sealing Cap**



IP68/69K Metal terminal

Part number
UTS8DCGE

**Plug Protective Cap**



IP40

Part number
UTS68C

**Plastic Protective Cap**



Part numbers	
Receptacle cap	Plug cap
85005585A	85005594

**Gasket**



Part numbers
UTFD11B

**Color Coding Rings**

G for Green 

Y for Yellow 

R for Red 

Part numbers	
Receptacles	Plugs
UTS78CCRR	UTS68CCRR
UTS78CCRY	UTS68CCRY
UTS78CCRG	UTS68CCRG

**8E3A/8E98 - 8D3A/8D98** (Shell size 8, 3x#20)

**Contacts**

#20	Contact type	Plating	Cable acceptance (AWG)	Wire stripping length
Hand solder	Loaded in the connector	Min 0.4μ gold over 0.8μ Ni	22 to 18	5 mm
PCB	Machined <sup>(1)</sup>	Min 0.4μ gold over 0.8μ Ni	-	-

3

(1): For dimensions see page 169

**Electrical Characteristics**

**UL**  
7A 250V UL94 HB

**CSA**  
7A 250V UL94 HB

**IEC**  
7A 50V 1.5kV 3

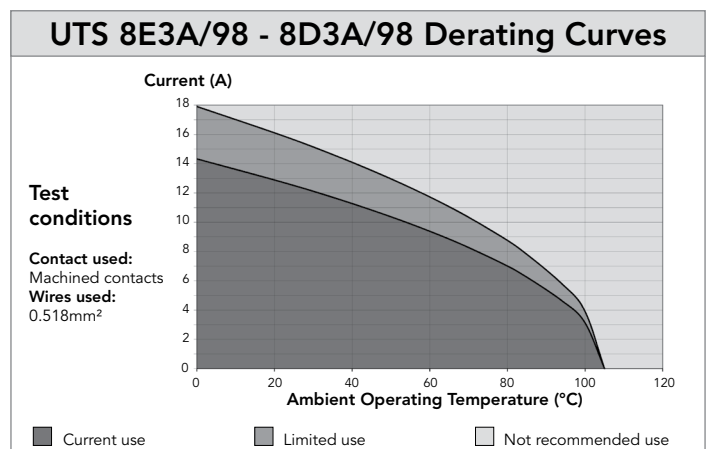

### 8E33/8D33 (Shell size 8, 3x#20)

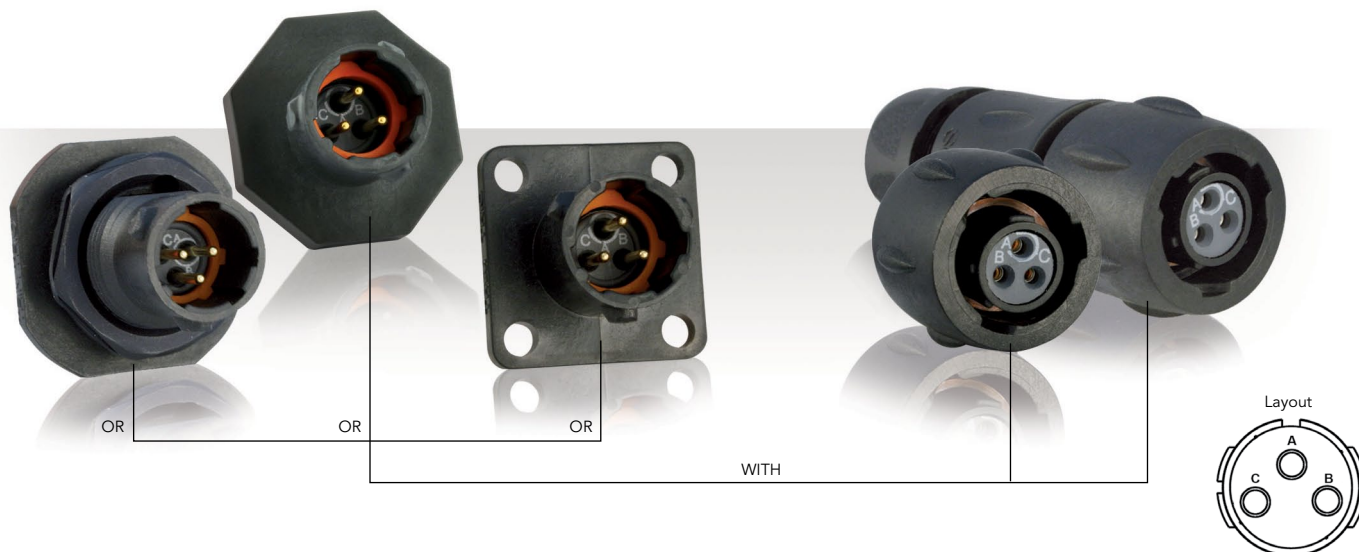

### Connector Part Numbers

Contact type	Connector type	Backshell	Part number	
			Male insert	Female insert
Hand solder electrical contacts loaded see page 47	Square flange receptacle	Without (Fig. 1)	<b>UTS08E33P</b>	<b>UTS08E33S</b>
	Plug	Without (Fig. 7)	<b>UTS68E33P</b>	<b>UTS68E33S</b>
		Cable gland (Fig. 8)	<b>UTS6JC8E33P</b>	<b>UTS6JC8E33S</b>
	Jam nut receptacle	Without (Fig. 4)	<b>UTS78E33P</b>	<b>UTS78E33S</b>
	M12 threaded receptacle	Without (Fig. 3)	<b>UTS78E33PM12</b>	<b>UTS78E33SM12</b>
PCB contacts loaded see page 47	Square flange receptacle	Without (Fig. 2)	<b>UTS08D33P</b>	<b>UTS08D33S</b>
	Jam nut receptacle with stand off and with hold down clips	Without (Fig. 6)	<b>UTS78D33P32</b>	<b>UTS78D33S32</b>
	Jam nut receptacle with stand off and without hold down clip	Without (Fig. 5)	<b>UTS78D33P</b>	<b>UTS78D33S</b>
	M12 threaded receptacle	Without (Fig. 3)	<b>UTS78D33PM12</b>	<b>UTS78D33SM12</b>

Possibilities of discrimination/keying methods see page 208

Sealed unmatd

### Overmoulded Cable Assembly Part Numbers

Overmoulding type	Connector type	Wire size (mm <sup>2</sup> )	Harmonized cable part number <sup>(1)</sup>	Part number (length: 1m.)*	
				Male plug	Female plug
Straight ending	Plug	0.5	H05 VV - F 3x0.5	<b>HAUTS0V8E33APST100</b>	<b>HAUTS0V8E33ASST100</b>
Right angle ending	Plug	0.5	H05 VV - F 3x0.5	<b>HAUTS0V8E33APRA100</b>	<b>HAUTS0V8E33ASRA100</b>

(1) Other cable available on demand

\* Other lengths available on demand

8E33/8D33 (Shell size 8, 3x#20)

Dimensions

3

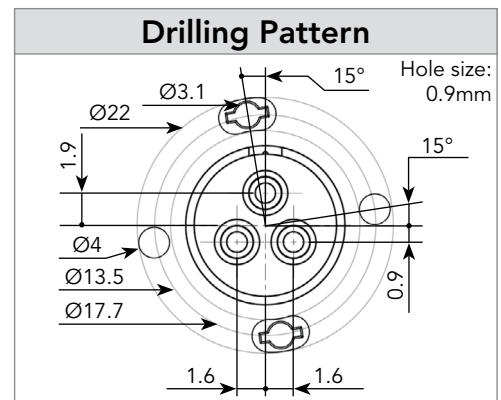
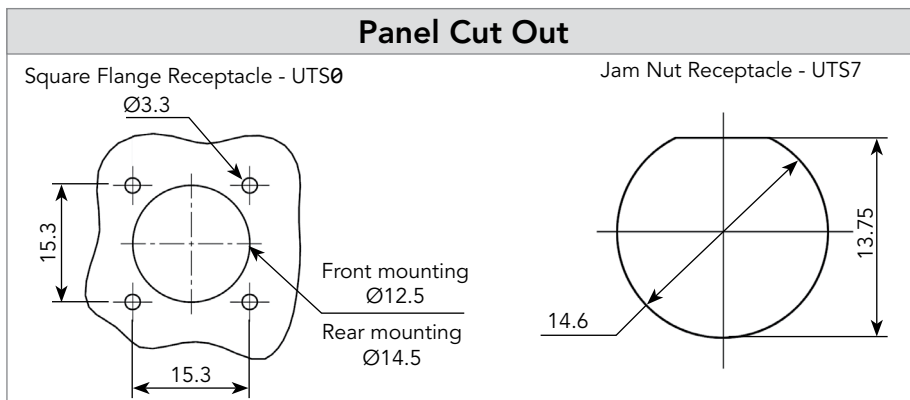
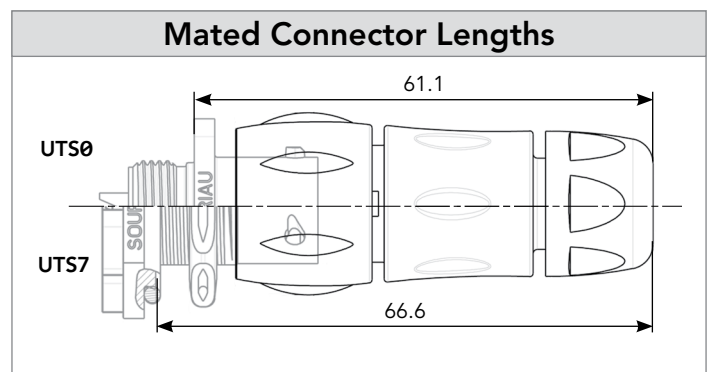
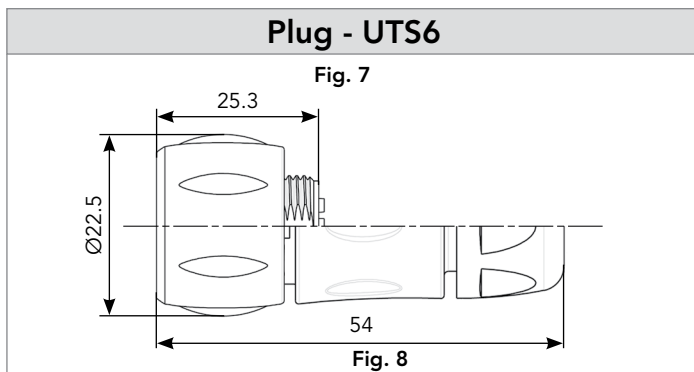
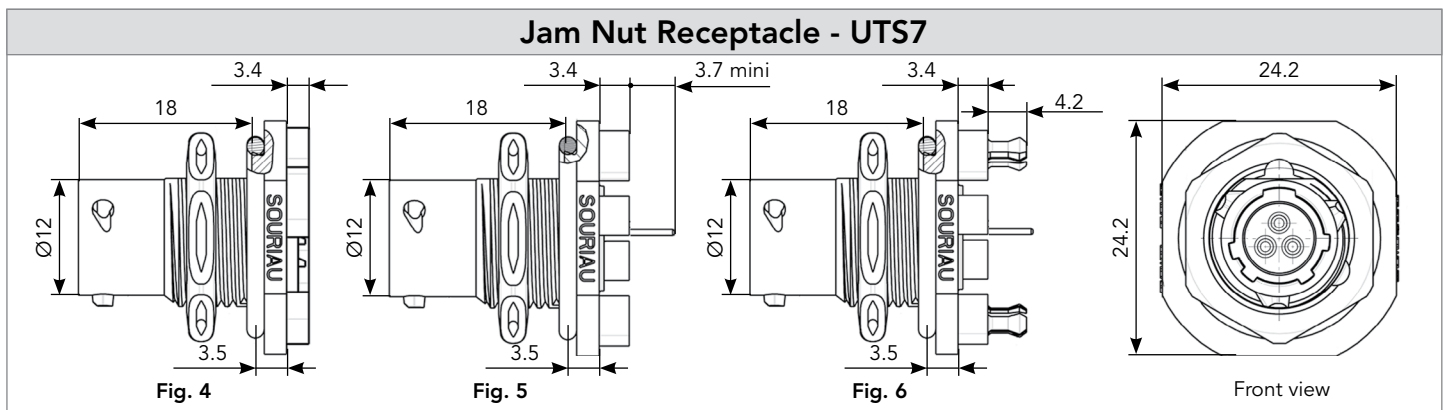
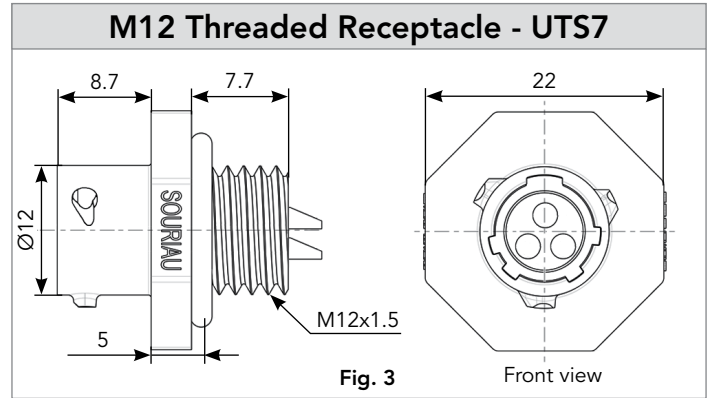
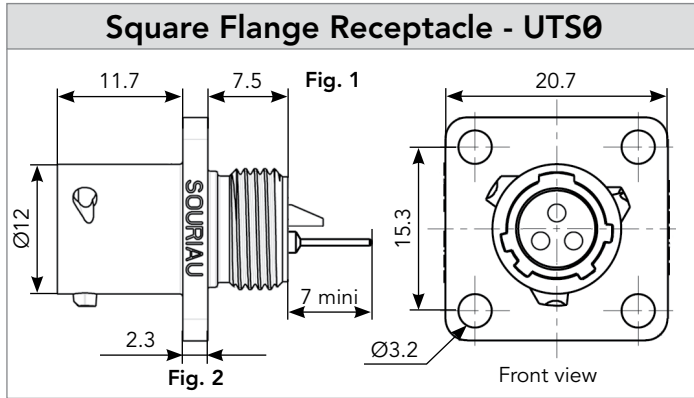

Note: Overmoulded cable assembly dimensions available page 179.

Note: all dimensions are in mm

**8E33/8D33** (Shell size 8, 3x#20)

**Accessories**

**Jam Nut Sealing Caps**



IP68/69K

Part number
UTS8DCG



IP68/69K Metal terminal

Part number
UTS8DCGR

**Square Flange Sealing Cap**



IP68/69K Metal terminal

Part number
UTS8DCGE

**Plug Protective Cap**



IP40

Part number
UTS68C

**Plastic Protective Cap**



Part numbers	
Receptacle cap	Plug cap
85005585A	85005594

**Gasket**



Part numbers
UTFD11B

**Color Coding Rings**

G for Green



Y for Yellow



R for Red



Part numbers	
Receptacles	Plugs
UTS78CCRR	UTS68CCRR
UTS78CCRY	UTS68CCRY
UTS78CCRG	UTS68CCRG

8E33/8D33 (Shell size 8, 3x#20)

Contacts

#20	Contact type	Plating	Cable acceptance (AWG)	Wire stripping length
Hand solder	Loaded in the connector	Min 0.4μ gold over 0.8μ Ni	22 to 18	5 mm
PCB	Machined <sup>(1)</sup>	Min 0.4μ gold over 0.8μ Ni	-	-

3

(1): For dimensions see page 169

**Electrical Characteristics**

**UL**  
7A 250V UL94 HB

**CSA**  
7A 250V UL94 HB

**IEC**  
7A 50V 1.5kV 3

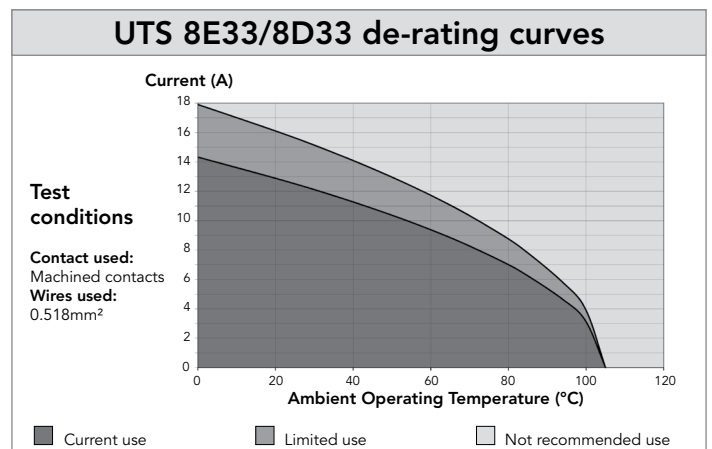

## 12E3/12D3 (Shell size 12, 3x#16)

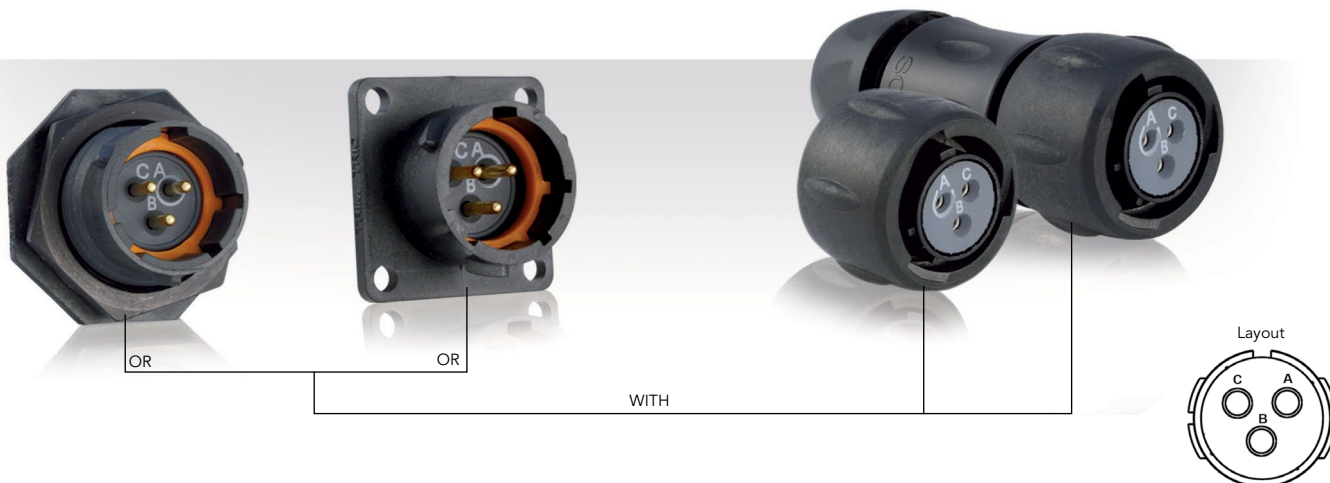

## Connector Part Numbers

Contact type	Connector type	Backshell	Part number	
			Male insert	Female insert
Hand solder electrical contacts loaded see page 51	Square flange receptacle	Without (Fig. 6)	<b>UTS012E3P</b>	<b>UTS012E3S</b>
	Plug	Without (Fig. 1)	<b>UTS612E3P</b>	<b>UTS612E3S</b>
		Cable gland (Fig. 2)	<b>UTS6JC12E3P</b>	<b>UTS6JC12E3S</b>
	Jam nut receptacle	Without (Fig. 3)	<b>UTS712E3P</b>	<b>UTS712E3S</b>
PCB contacts loaded see page 51	Square flange receptacle	Without (Fig. 7)	<b>UTS012D3P</b>	<b>UTS012D3S</b>
	Jam nut receptacle with stand off and with hold down clips	Without (Fig. 5)	<b>UTS712D3P32</b>	<b>UTS712D3S32</b>
	Jam nut receptacle with stand off and without hold down clip	Without (Fig. 4)	<b>UTS712D3P</b>	<b>UTS712D3S</b>

Possibilities of discrimination/keying methods see page 208

Sealed unmatod

## Overmoulded Cable Assembly Part Numbers

Overmoulding type	Connector type	Wire size (mm <sup>2</sup> )	Harmonized cable part number <sup>(1)</sup>	Part number (length: 1m.)*	
				Male plug	Female plug
Straight ending	Plug	1.5	H05 VV - F 3x1.5	<b>HAUTS0V12E3PST100</b>	<b>HAUTS0V12E3SST100</b>
Right angle ending	Plug	1.5	H05 VV - F 3x1.5	<b>HAUTS0V12E3PRA100</b>	<b>HAUTS0V12E3SRA100</b>

(1) Other cable available on demand

\* Other lengths available on demand



12E3/12D3 (Shell size 12, 3x#16)

Dimensions

3

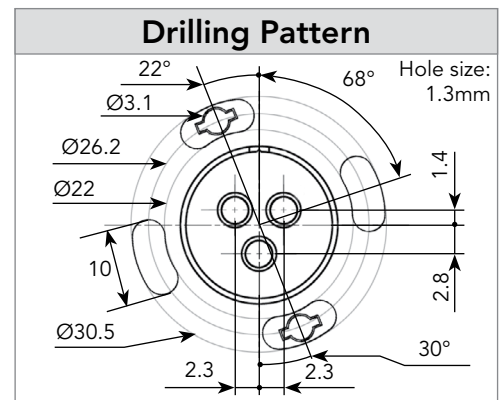
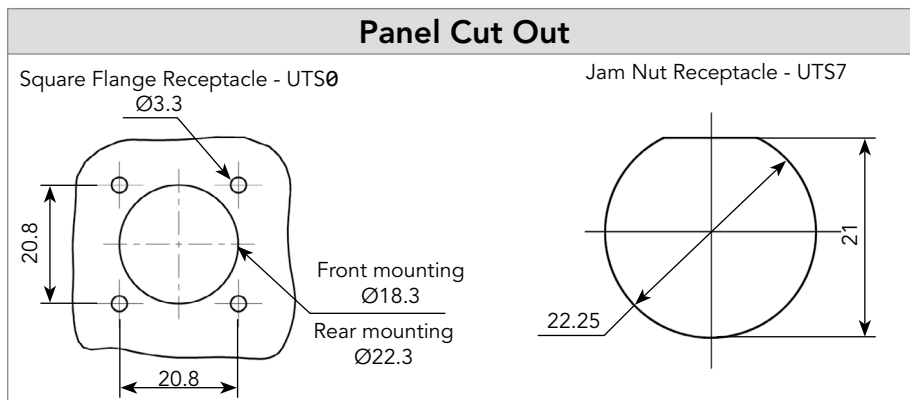
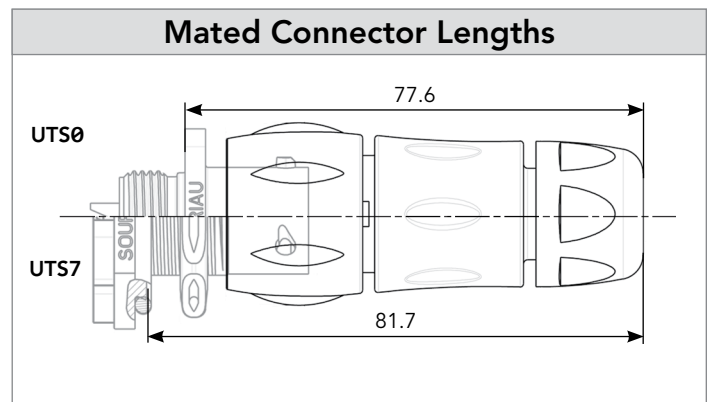
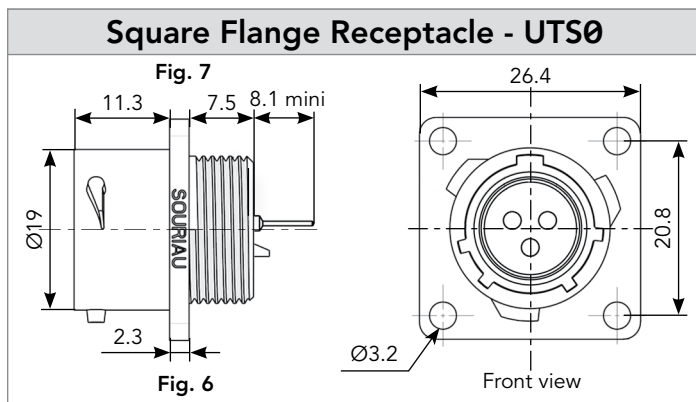
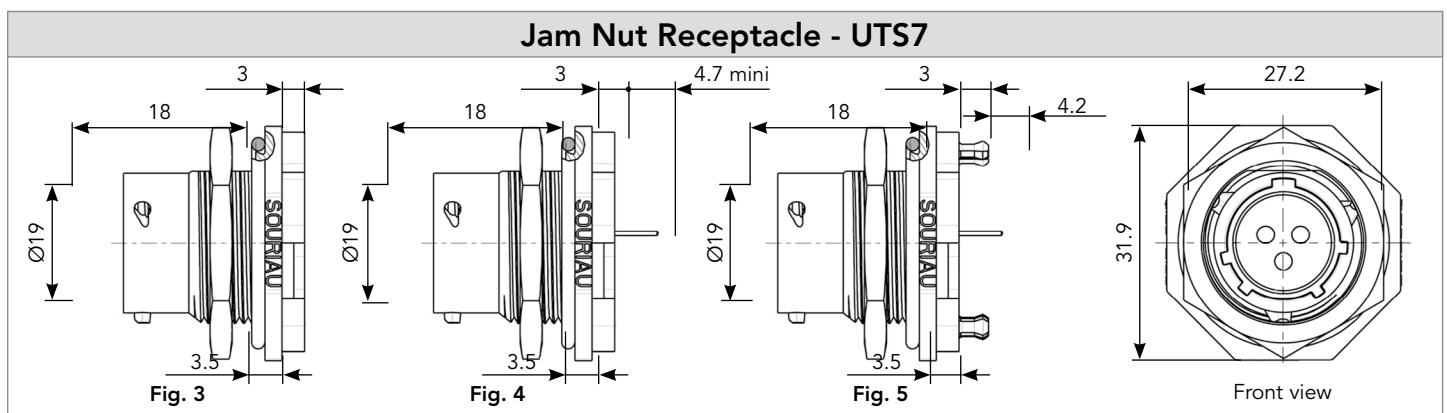
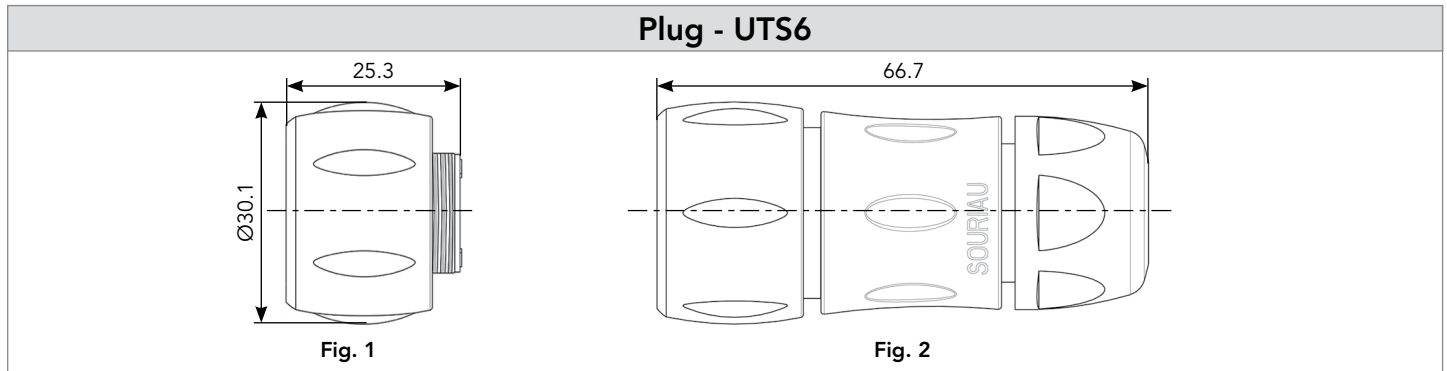

Note: Overmoulded cable assembly dimensions available page 179.

Note: all dimensions are in mm

# 12E3/12D3 (Shell size 12, 3x#16)

## Accessories

### Jam Nut Sealing Caps



IP68/69K

Part number
UTS12DCG



IP68/69K Metal terminal

Part number
UTS12DCGR

### Plug Sealing Cap



IP68/69K

Part number
UTS612DCG

### Square Flange Sealing Cap



IP68/69K Metal terminal

Part number
UTS12DCGE

### Plastic Protective Cap



Part numbers	
Receptacle cap	Plug cap
85005587A	85005596

### Gasket



Part numbers
UTFD13B

### Color Coding Rings

G for Green 

Y for Yellow 

R for Red 

Part numbers	
Receptacles	Plugs
UTS712CCRR	UTS612CCRR
UTS712CCRY	UTS612CCRY
UTS712CCRG	UTS612CCRG

## 12E3/12D3 (Shell size 12, 3x#16)

### Contacts

#16	Contact type	Plating	Cable acceptance (AWG)	Wire stripping length
Hand solder	Loaded in the connector	Min 0.4μ gold over 0.8μ Ni	18 to 14	5 mm
PCB	Machined <sup>(1)</sup>	Min 0.4μ gold over 0.8μ Ni	-	-

(1): For dimensions see page 169

3

#### Electrical Characteristics

**UL**  
13A 600V UL94 HB

**CSA**  
13A 600V UL94 HB

**IEC**  
16A 150V 2.5kV 3

#### UTS 12E3/12D3 Derating Curves

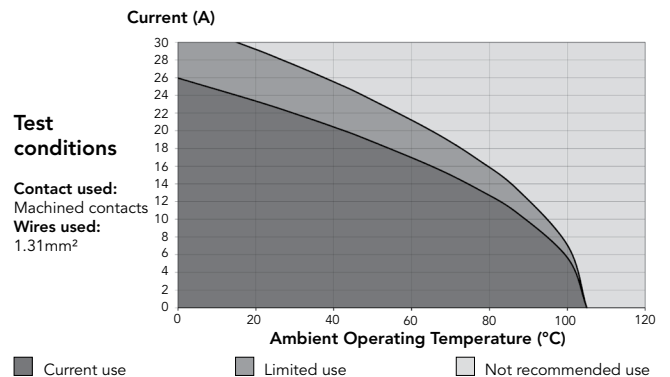

## 124 - 12E4/12D4 (Shell size 12, 3 + ground, 4x#16)



### Connector Part Numbers

Contact type	Connector type	Backshell	Part number	
			Male insert	Female insert
Crimp contacts supplied separately see page 55	Square flange receptacle	Without (Fig. 1)	<b>UTS0124P</b>	-
	Jam nut receptacle	Without (Fig. 4)	<b>UTS7124P</b>	<b>UTS7124S</b>
	Free hanging receptacle	Cable gland (Fig. 12)	<b>UTS1JC124P</b>	<b>UTS1JC124S</b>
	Plug	Without (Fig. 10)	<b>UTS6124P</b>	<b>UTS6124S</b>
Cable gland (Fig. 11)		<b>UTS6JC124P</b>	<b>UTS6JC124S</b>	
Screw contacts loaded	Jam nut receptacle	Without (Fig. 6 & 7)	<b>UTS7124PSCR</b>	<b>UTS7124SSCR</b>
	Plug	Without (Fig. 10)	<b>UTS6124PSCR</b>	<b>UTS6124SSCR</b>
		Cable gland (Fig. 11)	<b>UTS6JC124PSCR</b>	<b>UTS6JC124SSCR</b>
Free hanging receptacle	Cable gland (Fig. 9)	<b>UTS1JC124PSCR</b>	-	
PCB contacts supplied separately see page 55	Square flange receptacle	Without (Fig. 3)	<b>UTS0124P</b>	-
	Jam nut receptacle	Without (Fig. 5)	<b>UTS7124P</b>	<b>UTS7124S</b>
Hand solder electrical contacts loaded see page 55	Square flange receptacle	Without (Fig. 2)	<b>UTS012E4P</b>	<b>UTS012E4S</b>
	Jam nut receptacle	Without (Fig. 9)	<b>UTS712E4P</b>	<b>UTS712E4S</b>
	Plug	Without (Fig. 10)	<b>UTS612E4P</b>	<b>UTS612E4S</b>
	Plug	Cable gland (Fig. 11)	<b>UTS6JC12E4P</b>	<b>UTS6JC12E4S</b>
PCB contacts loaded	Square flange receptacle	Without (Fig. 3)	<b>UTS012D4P</b>	<b>UTS012D4S</b>
	Jam nut receptacle with stand off and without hold down clip	Without (Fig.8)	<b>UTS712D4P</b>	<b>UTS712D4S</b>
	Jam nut receptacle with stand off and with hold down clips	Without (Fig. 9)	<b>UTS712D4P32</b>	<b>UTS712D4S32</b>

Sealed unmatod

### Overmoulded Cable Assembly Part Numbers

Overmoulding type	Connector type	Wire size (mm <sup>2</sup> )	Harmonized cable part number <sup>(1)</sup>	Part number (length: 1m.)*	
				Male plug	Female plug
Straight ending	Plug	1.5	H05 VV - F 4x1.5	<b>HAUTS0V124PST100</b>	<b>HAUTS0V124SST100</b>
				<b>HAUTS0V12E4PST100</b>	<b>HAUTS0V12E4SST100</b>
Right angle ending	Plug	1.5	H05 VV - F 4x1.5	<b>HAUTS0V124PRA100</b>	<b>HAUTS0V124SRA100</b>
				<b>HAUTS0V12E4PRA100</b>	<b>HAUTS0V12E4SRA100</b>

(1) Other cable available on demand

\* Other lengths available on demand

124 - 12E4/12D4 (Shell size 12, 3 + ground, 4x#16)

Dimensions

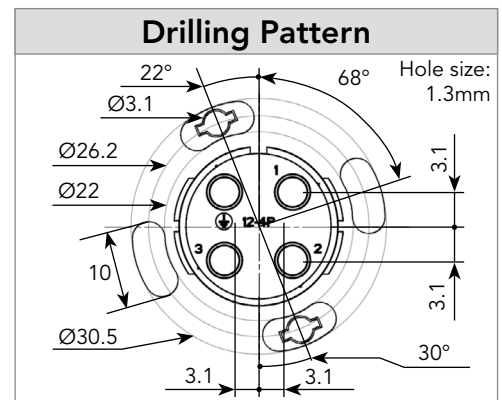
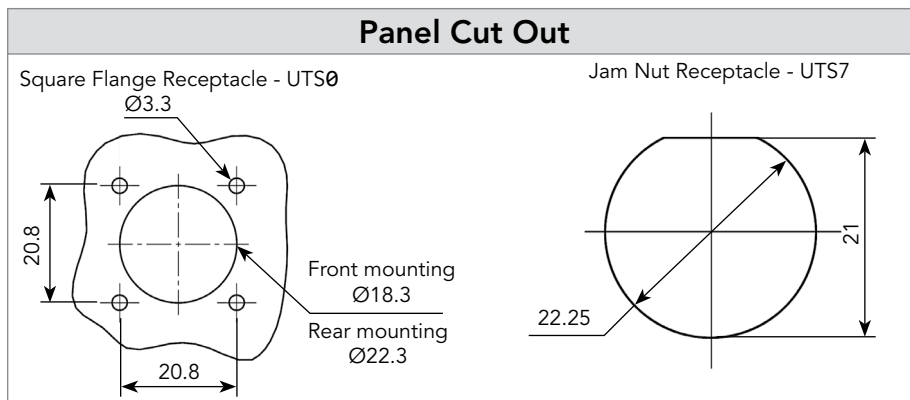
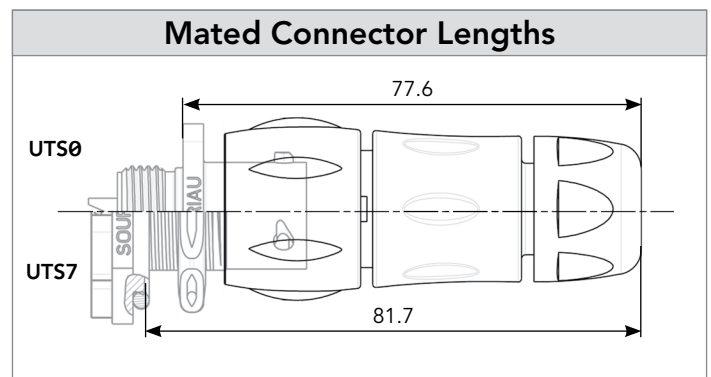
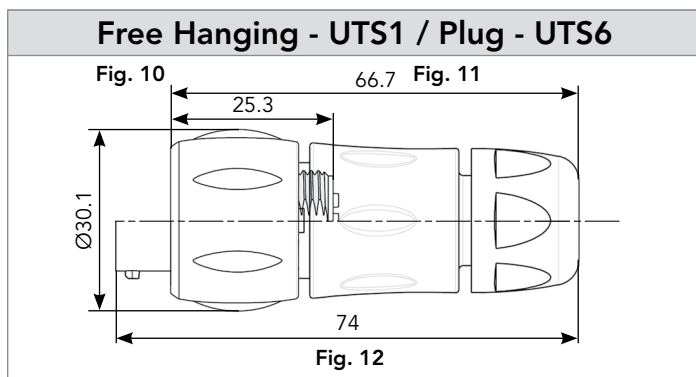
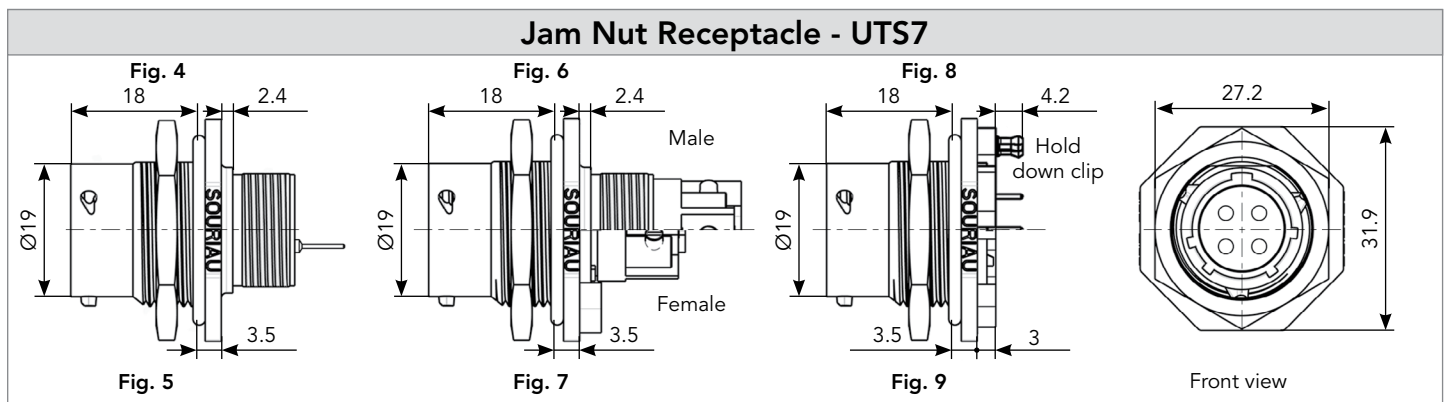
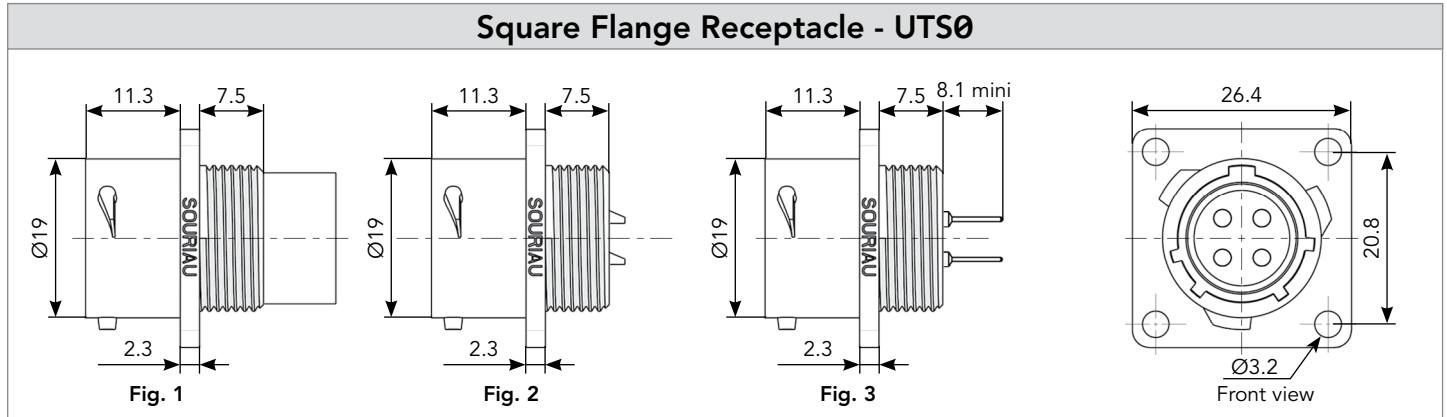

Note: Overmoulded cable assembly dimensions available page 179.

Note: all dimensions are in mm

# 124 - 12E4/12D4 (Shell size 12, 3 + ground, 4x#16)

## Accessories and Tooling

### Jam Nut Sealing Caps



IP68/69K

Part number
UTS12DCG



IP68/69K Metal terminal

Part number
UTS12DCGR

### Handle (without Head)



Part number
SHANDLES

### Tool Kit



Part number
TOOLKIT

### Plug Sealing Cap



IP68/69K

Part number
UTS612DCG

### Square Flange Sealing Cap



IP68/69K Metal terminal

Part number
UTS12DCGE

### Crimp Tooling (without Shandles)



Contacts	Contact size	Part number of head	
RM/RC 28M1K <sup>(1)</sup>	Standard contacts #16 Ø 1.6mm	S16RCM20*	
RM/RC 24M9K <sup>(1)</sup>		S16RCM20*	
RM/RC 20M13K <sup>(1)</sup>		S16RCM20*	
RM/RC 20M12K <sup>(1)</sup>		S16RCM20*	
RM/RC 16M23K <sup>(1)</sup>		S16RCM16*	
RM/RC 14M30K <sup>(1)</sup>		S16RCM14*	
SM/SC 24ML1TK6 <sup>(1)</sup>		S16SCM20*	
SM/SC 20ML1TK6 <sup>(1)</sup>		S16SCM20*	
SM/SC 16ML1TK6 <sup>(1)</sup>		S16SCML1*	
SM/SC 14ML1TK6 <sup>(1)</sup>		S16SCML1*	
SM/SC 16ML11TK6 <sup>(1)</sup>		S16SCML11*	
RMDXK10D28K		Coaxial contacts	M10S1J with die set & stop bushing see page 200 to 204
RCDXK1D28K			
RM/RC DX60xxD28K			
RM/RC DXK10D28 + yorK090			
RM/RC DX60xxD28			

<sup>(1)</sup>: Example of plating, for other plating options see page 164  
\* Heads to be used with handle PN: SHANDLES

### Plastic Protective Cap



Part numbers	
Receptacle cap	Plug cap
85005587A	85005596

### Gasket



Part numbers
UTFD13B

### Color Coding Rings

G for Green 

Y for Yellow 

R for Red 

Part numbers	
Receptacles	Plugs
UTS712CCRR	UTS612CCRR
UTS712CCRY	UTS612CCRY
UTS712CCRG	UTS612CCRG



# 124 - 12E4/12D4 (Shell size 12, 3 + ground, 4x#16)

## Contacts

#16	Contact type	AWG	Part number		Max wire Ø	Max insulator Ø
			Male	Female		
Crimp	Machined	30-28	RM28M1K <sup>(1)</sup>	RC28M1K <sup>(1)</sup>	0.55	1.00
		26-24	RM24M9K <sup>(1)</sup>	RC24M9K <sup>(1)</sup>	0.80	1.60
		22-20	RM20M13K <sup>(1)</sup>	RC20M13K <sup>(1)</sup>	1.15	1.80
		22-20	RM20M12K <sup>(1)</sup>	RC20M12K <sup>(1)</sup>	1.15	2.20
		20-16	RM16M23K <sup>(1)</sup>	RC16M23K <sup>(1)</sup>	1.80	3.20
		16-14	RM14M30K <sup>(1)</sup>	RC14M30K <sup>(1)</sup>	2.30	3.20
	Stamped & Formed reeled contacts See note (2) for loose piece	26-24	SM24M1TK6 <sup>(1)(2)</sup>	SC24M1TK6 <sup>(1)(2)</sup>	-	0.90-1.60
		22-20	SM20M1TK6 <sup>(1)(2)</sup>	SC20M1TK6 <sup>(1)(2)</sup>	-	1.20-2.10
		18-16	SM16M1TK6 <sup>(1)(2)</sup>	SC16M1TK6 <sup>(1)(2)</sup>	-	3.20
		18-16	SM16M11TK6 <sup>(1)(2)</sup>	SC16M11TK6 <sup>(1)(2)</sup>	-	3.00
14		SM14M1TK6 <sup>(1)(2)</sup>	SC14M1TK6 <sup>(1)(2)</sup>	-	3.20	
PCB	Machined <sup>(3)</sup>	-	RM20M12E83K <sup>(1)</sup>	RC20M12E84K <sup>(1)</sup>	-	-
Coaxial	Cable Multipiece	see pages 167, 200 to 206	RMDXK10D28	RCDXK1D28	-	-
	Cable Monocrimp		RMDX60xxD28	RCDX60xxD28	-	-
	Twisted pair Multipiece		RMDXK10D28 + york090	RCDXK1D28 + york090	-	-
	Twisted pair Monocrimp		RMDX60xxD28	RCDX60xxD28	-	-
Fiber optic	POF contacts (Plastic Optical Fiber)	-	RMPOF1000	RCPOF1000B	-	-
Hand-solder	Loaded in the connector	14-18	-	-	-	-



(1): Example of plating, for other plating see page 164 (2): Loose piece contact available if putting L. Example: SM20M1TK6 (3): For dimensions see page 168 Note: all dimensions are in mm

### Electrical Characteristics

**UL**  
10A 500V UL94 V-0

**CSA**  
7A 500V UL94 V-0

**IEC**  
16A 300V 4kV 3  
Temperature elevation: 50°C

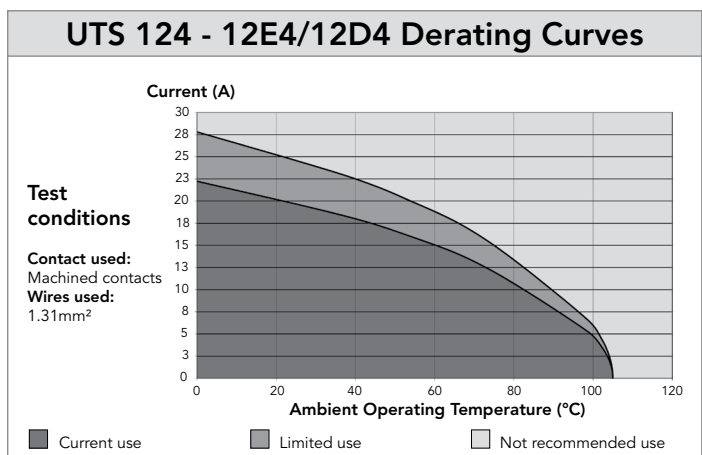

**183G1** (Shell size 18, 3 + ground, 4x#8)



**Connector Part Numbers**

Contact type	Connector type	Backshell	Part number	
			Male insert	Female insert
Crimp contacts supplied separately see page 59	NPT threaded receptacle	Without (Fig. 1)	-	<b>UTS7183G1SNPT</b>
	Plug	Without (Fig. 2)	<b>UTS6183G1P</b>	-
	Plug	Cable gland (Fig. 3)	<b>UTS6JC183G1P</b>	-
PCB contacts supplied separately see page 59	NPT threaded receptacle	Without (Fig. 1)	-	<b>UTS7183G1SNPT</b>
	Plug	Without (Fig. 2)	<b>UTS6183G1P</b>	-



**183G1** (Shell size 18, 3 + ground, 4x#8)

**Dimensions**

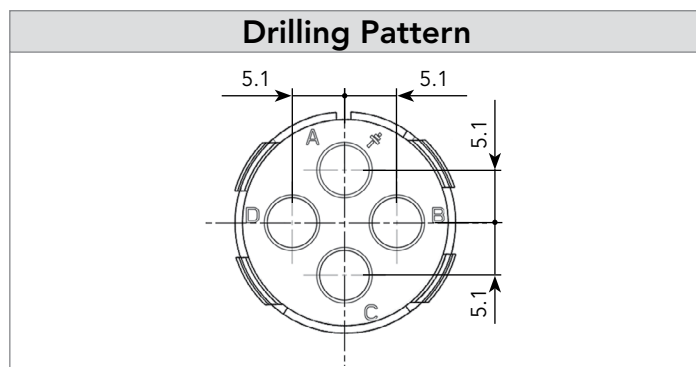
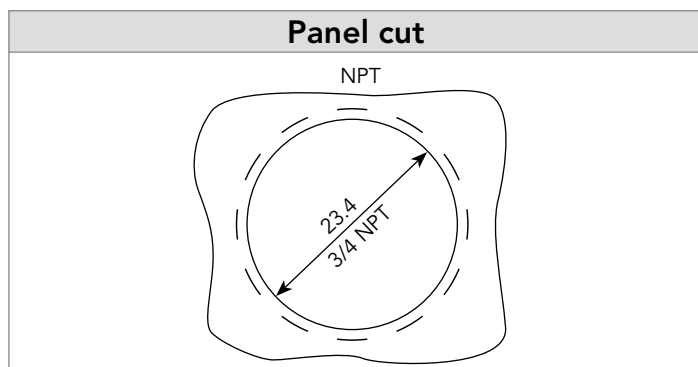
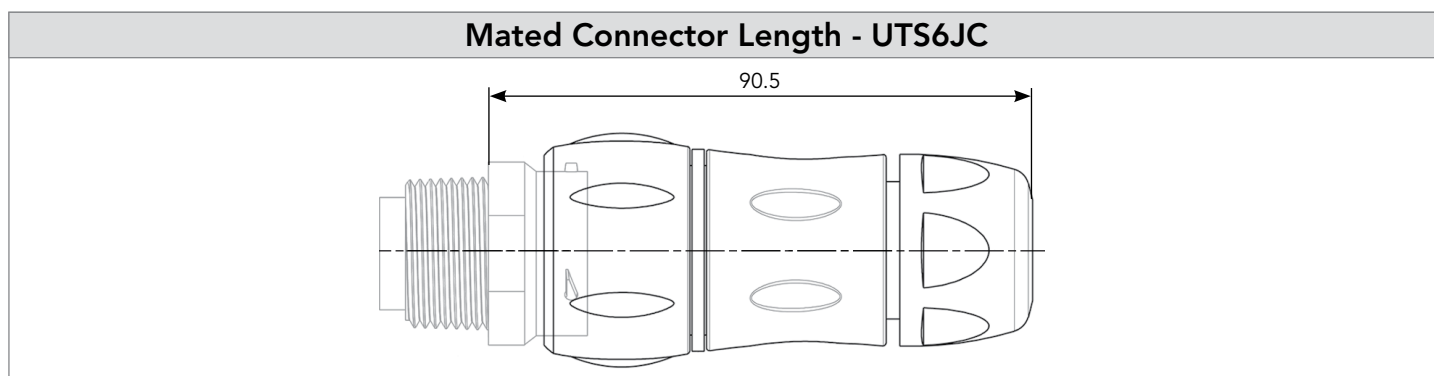
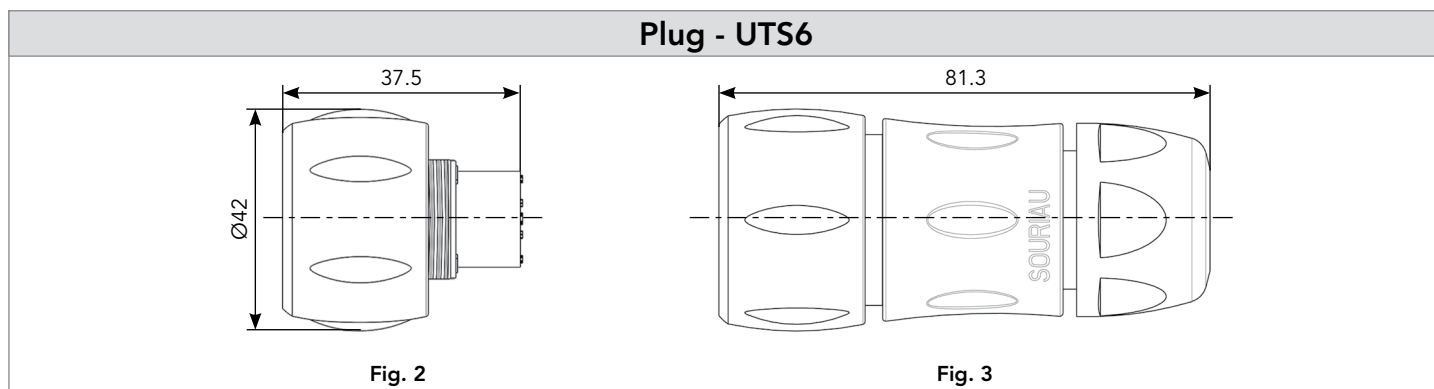
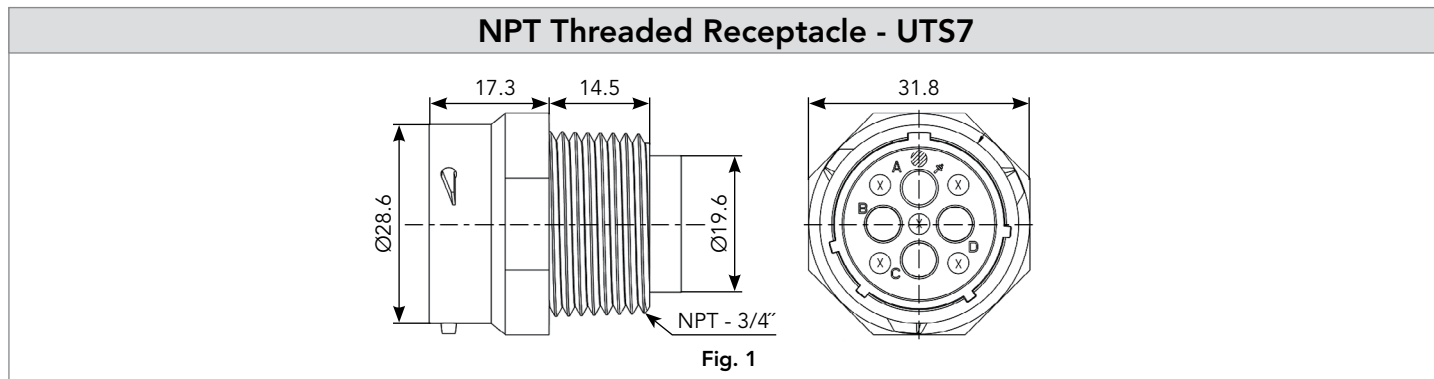

Note: all dimensions are in mm

# 183G1 (Shell size 18, 3 + ground, 4x#8)

## Accessories and Tooling

### Jam Nut or NPT Threaded Receptacle Sealing Caps



IP68/69K

Part number  
UTS18DCG



IP68/69K Metal terminal

Part number  
UTS18DCGR

### Plug Sealing Cap



IP68/69K

Part number  
UTS618DCG

### Plastic Protective Cap



Part numbers

Receptacle cap	Plug cap
85005590A	85005599

### Gasket



Part numbers

UTFD16B

### Color Coding Rings

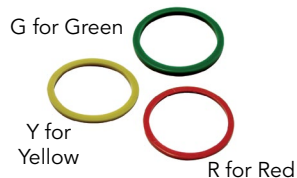

Part numbers	
Receptacles	Plugs
UTS718CCRR	UTS618CCRR
UTS718CCRY	UTS618CCRY
UTS718CCRG	UTS618CCRG

### Hand Tool



Part number  
M317

### Positioner + Locator Setting #8



Part number  
VGE10078A

### Extraction Tool #8



Part number  
51060210936

**183G1** (Shell size 18, 3 + ground, 4x#8)

**Contacts**

#8	Contact type	AWG	Part number		Max wire Ø	Max insulator Ø
			Male	Female		
Crimp	Machined	16	82913601A <sup>(1)</sup>	82913600A <sup>(1)</sup>	1.72 mm	6.5 mm
		14	82913603A <sup>(1)</sup>	82913602A <sup>(1)</sup>	2.22 mm	
		12	82913605A <sup>(1)</sup>	82913604A <sup>(1)</sup>	2.82 mm	
		10	82913607A <sup>(1)</sup>	82913606A <sup>(1)</sup>	3.50 mm	
		8	82913609A <sup>(1)</sup>	82913608A <sup>(1)</sup>	4.35 mm	
PCB	Machined <sup>(2)</sup>	-	82911685NPC <sup>(1)</sup>	82911684NPC <sup>(1)</sup>	-	-

(1): Example of plating, for other plating see page 164  
 (2): For dimensions see page 168



Electrical Characteristics
<p><b>UL</b> 44A 600V UL94 V-0</p> <p><b>CSA</b> 26A 600V UL94 V-0</p> <p><b>IEC</b> 32A 300V 4kV 3</p>

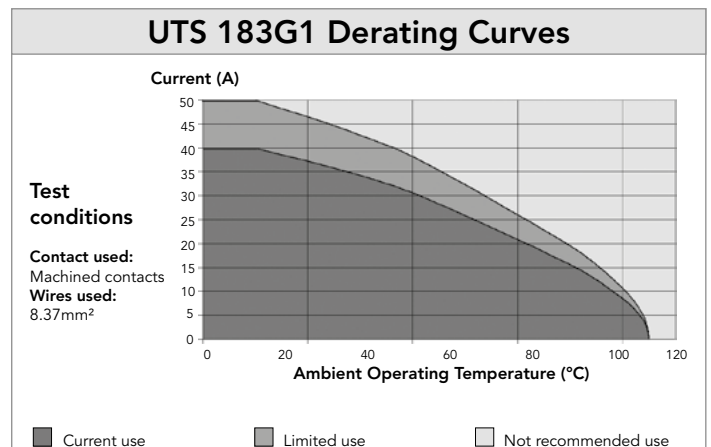

### 8E4/8D4 (Shell size 8, 4x#20)

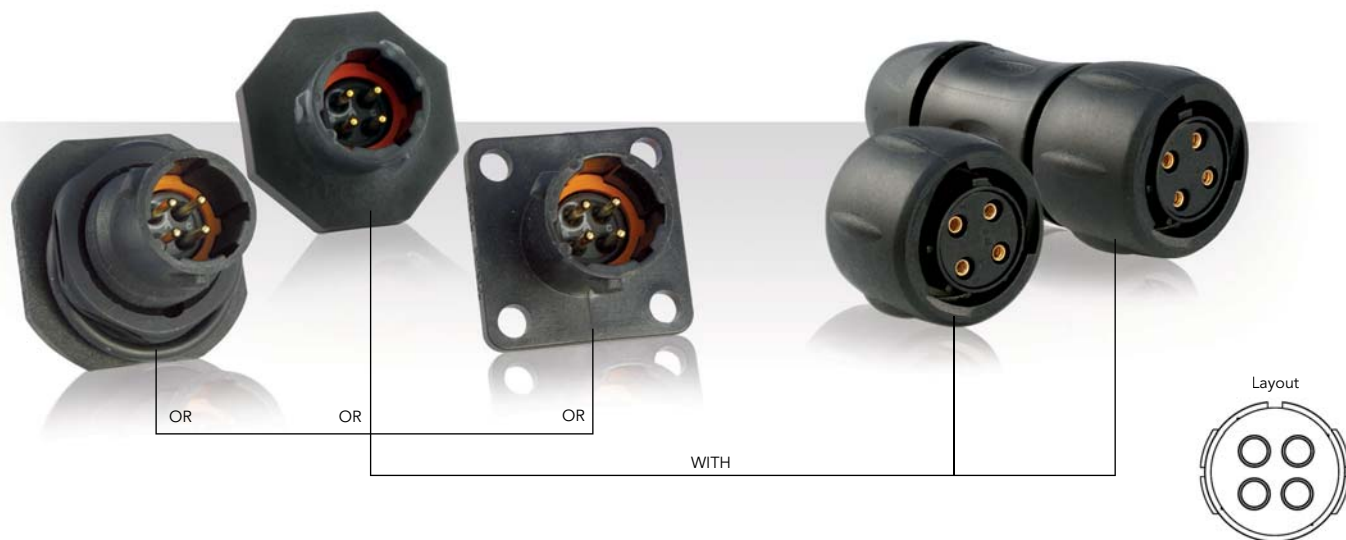

### Connector Part Numbers

Contact type	Connector type	Backshell	Part number	
			Male insert	Female insert
Hand solder electrical contacts loaded see page 63	Square flange receptacle	Without (Fig. 1)	<b>UTS08E4P</b>	<b>UTS08E4S</b>
	Plug	Without (Fig. 7)	<b>UTS68E4P</b>	<b>UTS68E4S</b>
		Cable gland (Fig. 8)	<b>UTS6JC8E4P</b>	<b>UTS6JC8E4S</b>
	Jam nut receptacle	Without (Fig. 4)	<b>UTS78E4P</b>	<b>UTS78E4S</b>
	M12 threaded receptacle	Without (Fig. 3)	<b>UTS78E4PM12</b>	<b>UTS78E4SM12</b>
PCB contacts loaded see page 63	Square flange receptacle	Without (Fig. 2)	<b>UTS08D4P</b>	<b>UTS08D4S</b>
	Jam nut receptacle with stand off and with hold down clips	Without (Fig. 6)	<b>UTS78D4P32</b>	<b>UTS78D4S32</b>
	Jam nut receptacle with stand off and without hold down clip	Without (Fig. 5)	<b>UTS78D4P</b>	<b>UTS78D4S</b>

Possibilities of discrimination/keying methods see page 208

Sealed unmatd

### Overmoulded Cable Assembly Part Numbers

Overmoulding type	Connector type	Wire size (mm <sup>2</sup> )	Harmonized cable part number <sup>(1)</sup>	Part number (length: 1m.)*	
				Male plug	Female plug
Straight ending	Plug	1.5	H05 VV - F 4x1.5	<b>HAUTS0V8E4PST100</b>	<b>HAUTS0V8E4SST100</b>
Right angle ending	Plug	1.5	H05 VV - F 4x1.5	<b>HAUTS0V8E4PRA100</b>	<b>HAUTS0V8E4SRA100</b>

(1) Other cable available on demand

\* Other lengths available on demand

8E4/8D4 (Shell size 8, 4x#20)

Dimensions

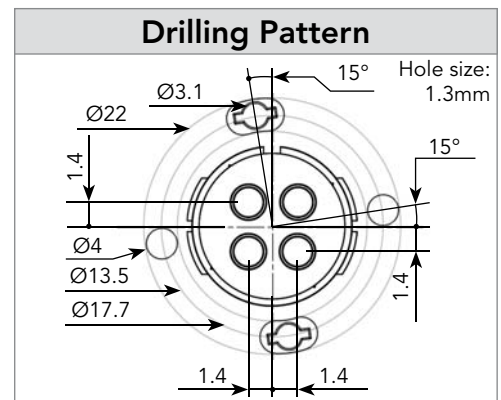
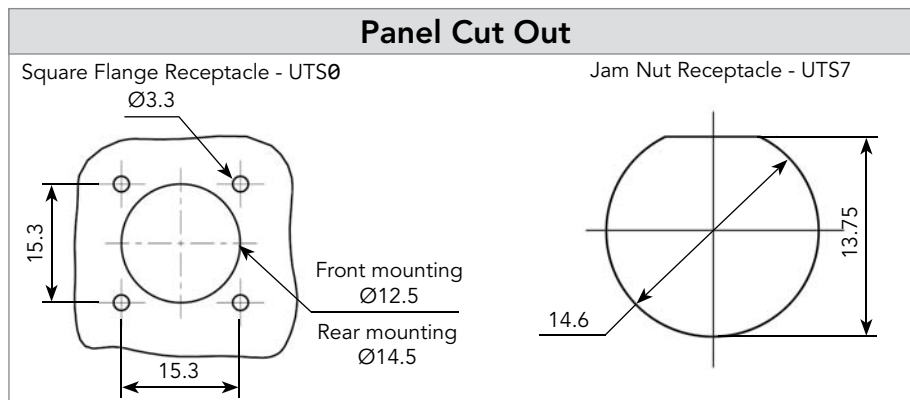
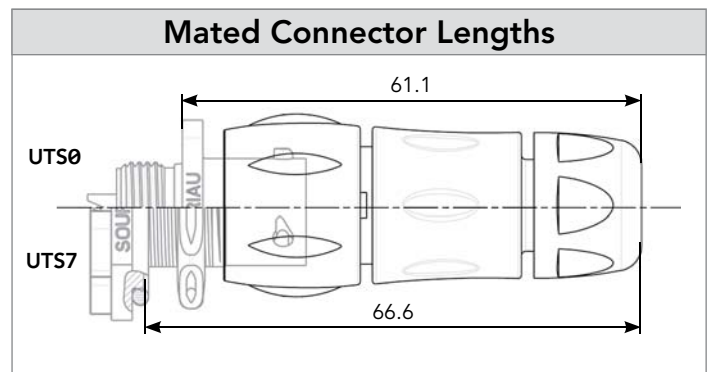
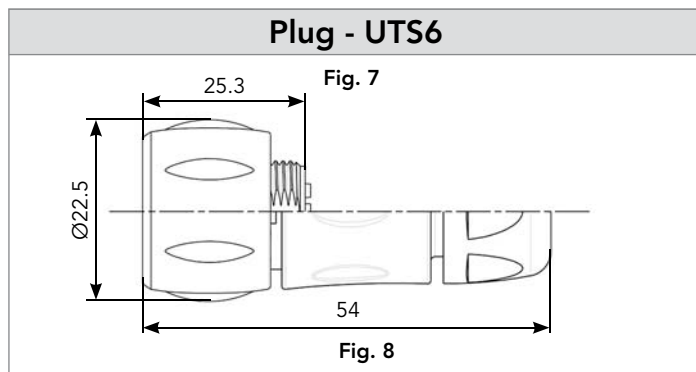
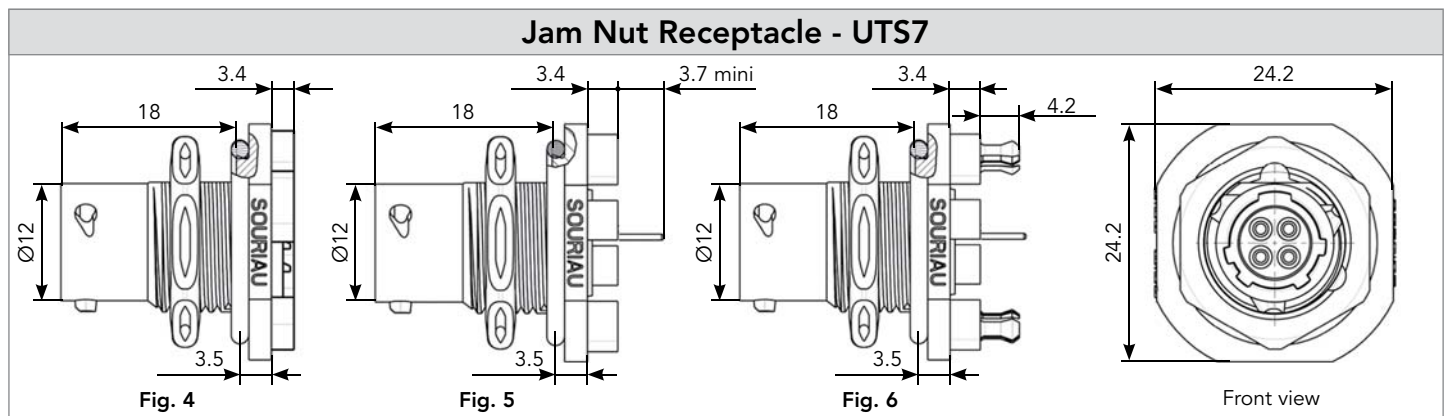
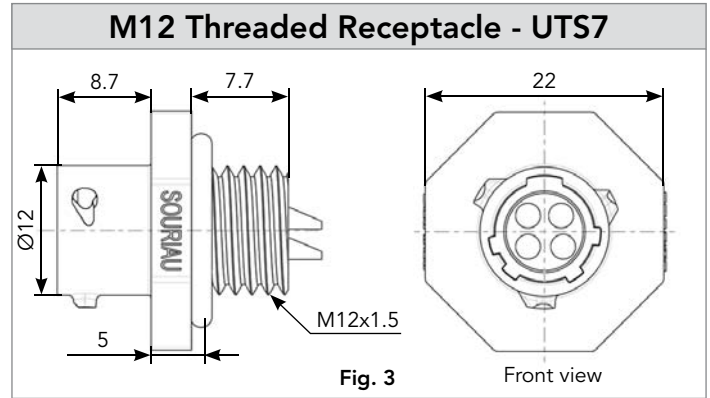
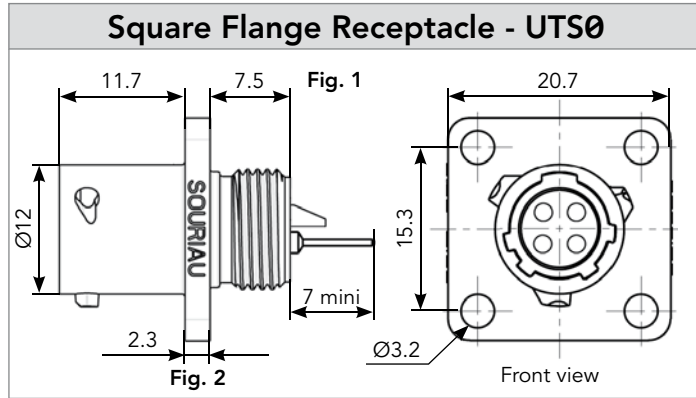

Note: Overmoulded cable assembly dimensions available page 179.

Note: all dimensions are in mm

**8E4/8D4** (Shell size 8, 4x#20)

**Accessories**

**Jam Nut Sealing Caps**



IP68/69K

Part number
UTS8DCG



IP68/69K Metal terminal

Part number
UTS8DCGR

**Square Flange Sealing Cap**



IP68/69K Metal terminal

Part number
UTS8DCGE

**Plug Protective Cap**



IP40

Part number
UTS68C

**Plastic Protective Cap**



Part numbers	
Receptacle cap	Plug cap
85005585A	85005594

**Gasket**



Part numbers
UTFD11B

**Color Coding Rings**

G for Green



Y for Yellow



R for Red



Part numbers	
Receptacles	Plugs
UTS78CCRR	UTS68CCRR
UTS78CCRY	UTS68CCRY
UTS78CCRG	UTS68CCRG

**8E4/8D4** (Shell size 8, 4x#20)

**Contacts**

#20	Contact type	Plating	Cable acceptance (AWG)	Wire stripping length
Hand solder	Loaded in the connector	Min 0.4μ gold over 0.8μ Ni	22 to 18	5 mm
PCB	Machined <sup>(1)</sup>	Min 0.4μ gold over 0.8μ Ni	-	-

(1): For dimensions see page 169

Electrical Characteristics
<p><b>UL</b> 7A 250V UL94 HB</p> <p><b>CSA</b> 7A 250V UL94 HB</p> <p><b>IEC</b> 7A 32V 1.5kV 3</p>

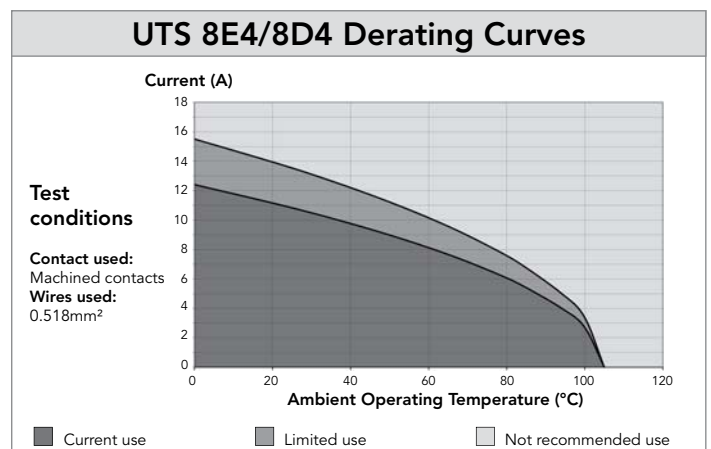

**102W2** (Shell size 10, 2x#20, 2x12)

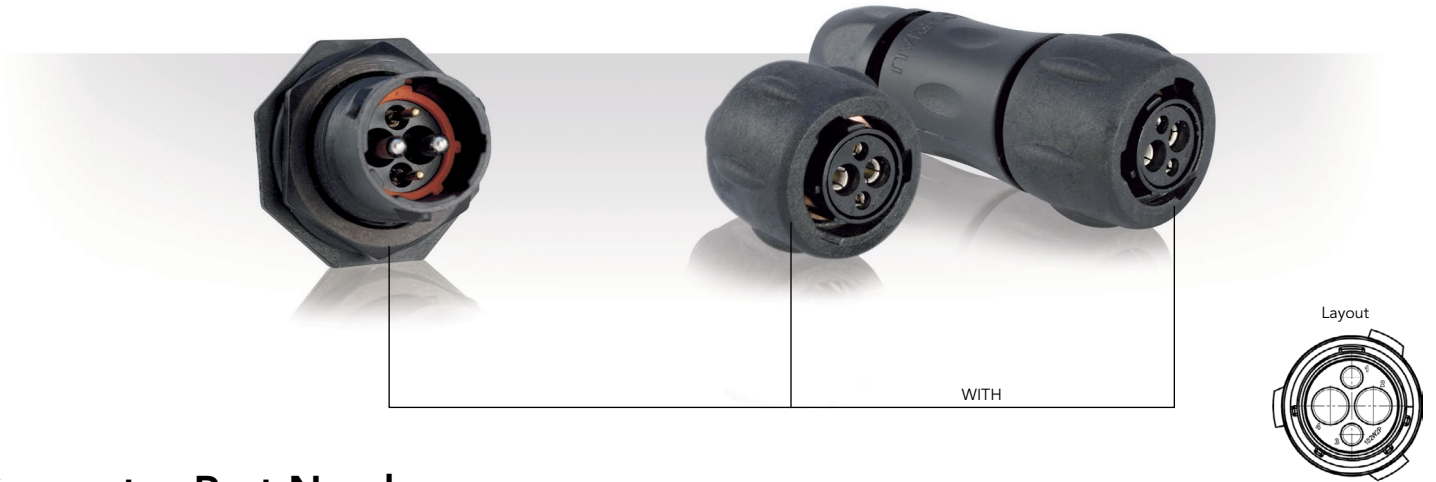

**Connector Part Numbers**

Contact type	Connector type	Backshell	Part number	
			Male insert	Female insert
Crimp contacts supplied separately see page 67	Free hanging receptacle	Cable gland (Fig. 1)	<b>UTS1JC102W2P</b>	<b>UTS1JC102W2S</b>
	Plug	Without (Fig. 2)	<b>UTS6102W2P</b>	<b>UTS6102W2S</b>
	Plug	Cable gland (Fig. 3)	<b>UTS6JC102W2P</b>	<b>UTS6JC102W2S</b>
	Jam nut receptacle	Without (Fig. 4)	<b>UTS7102W2P</b>	<b>UTS7102W2S</b>



102W2 (Shell size 10, 2x#20, 2x12)

Dimensions

4

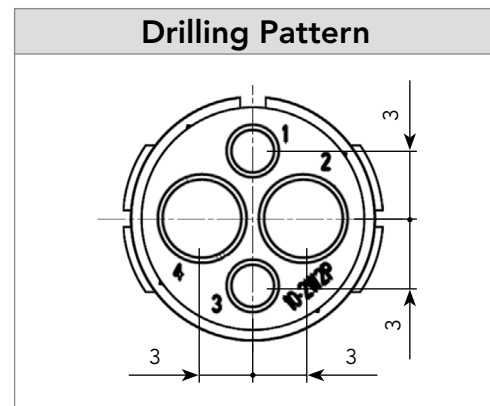
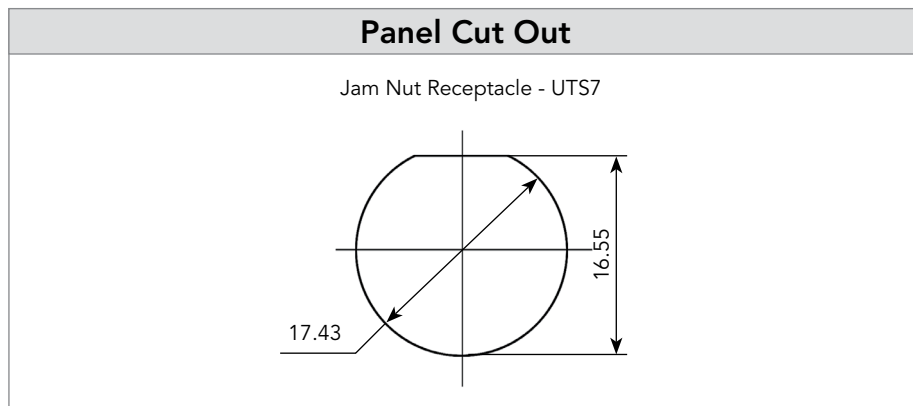
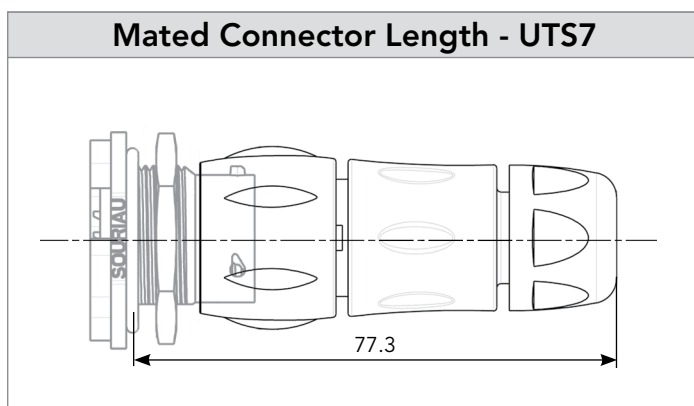
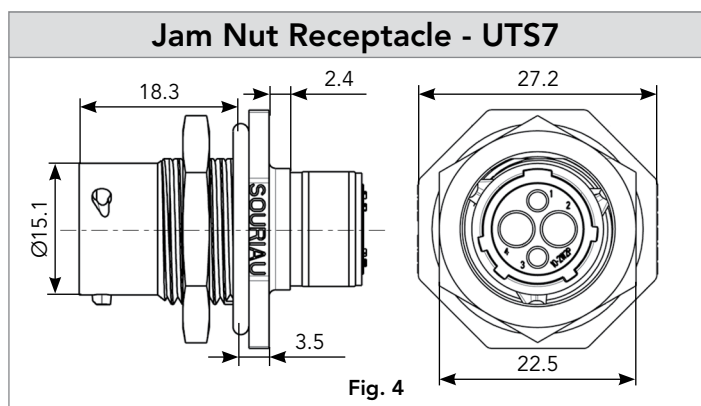
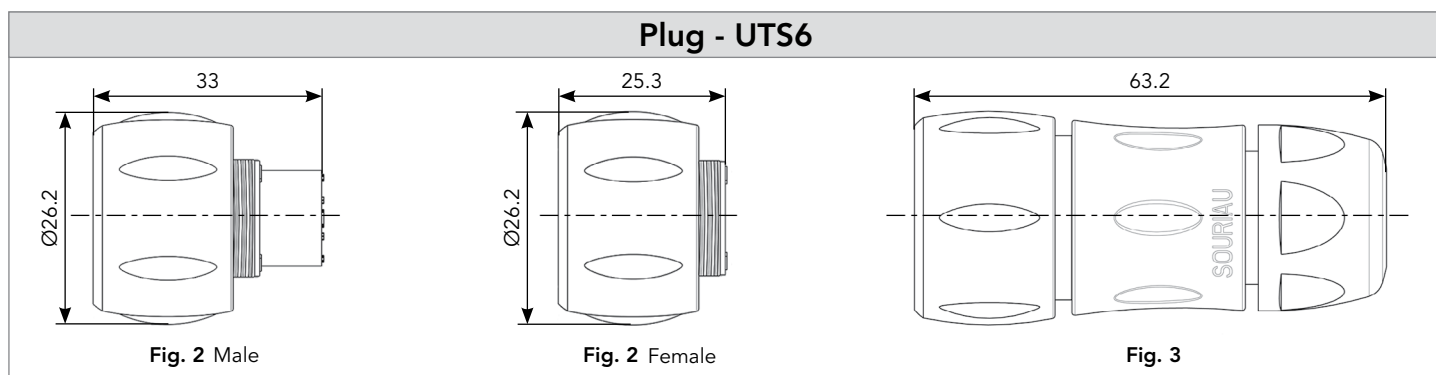
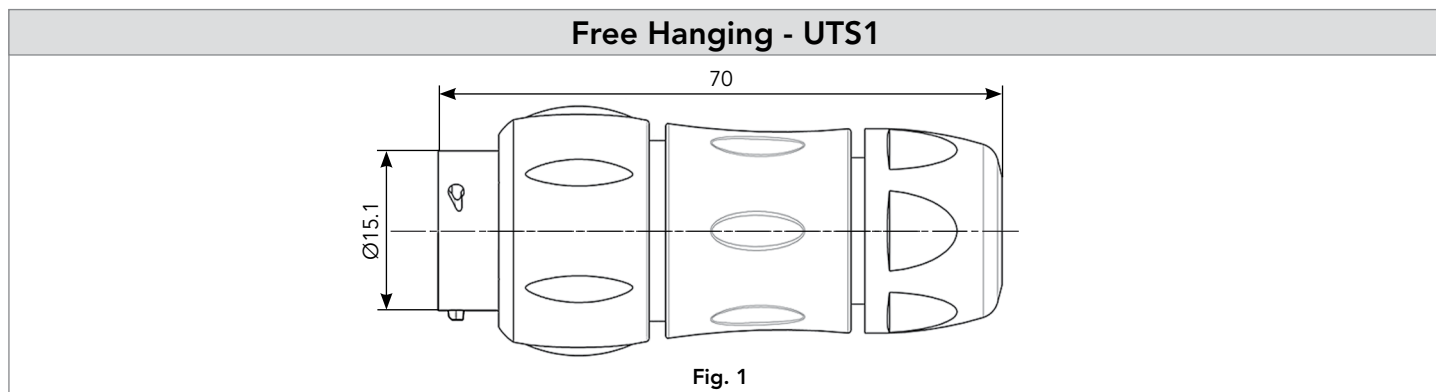

Note: all dimensions are in mm

# 102W2 (Shell size 10, 2x#20, 2x12)

## Accessories and Tooling

### Jam Nut Sealing Caps



IP68/69K

Part number
UTS10DCG



IP68/69K Metal terminal

Part number
UTS10DCGR

### Plug Sealing Cap



IP68/69K

Part number
UTS610DCG

### Extraction Tool #20



Part number
RX20D44

### Plastic Protective Cap



Part numbers	
Receptacle cap	Plug cap
85005586A	85005595

### Gasket



Part numbers
UTFD12B

### Color Coding Rings

G for Green



Y for Yellow



R for Red



Part numbers	
Receptacles	Plugs
UTS710CCRR	UTS610CCRR
UTS710CCRY	UTS610CCRY
UTS710CCRG	UTS610CCRG

### Crimp Tooling #20



Part number
SHANDLES



Part number
TOOLKIT



Contacts	Contact size	Part number of head
RM/RC 24W3K <sup>(1)</sup>	Standard contacts #20 Ø 1mm	S20RCM*
RM/RC 20W3K <sup>(1)</sup>		S20RCM*
RM/RC 18W3K <sup>(1)</sup>		S20RCM*
SM/SC 24WL3 <sup>(1)(2)</sup>		S20SCM20*
SM/SC 20WL3 <sup>(1)(2)</sup>		S20SCM20*

(1): Example of plating, for other plating options see page 156  
 (2): loose contact  
 \* Heads to be used with handle PN: SHANDLES

  
Handle

+

  
Head

=

  
Complete set

### Crimp Tooling #12



Part number hand tool
M317



Part number positioner + locator setting
VGE10078A

### Extraction Tool #12



Part number extraction tool
51060210924

# 102W2 (Shell size 10, 2x#20, 2x#12)

## Contacts

#20	Contact type	AWG	Part number		Max wire Ø	Max insulator Ø
			Male	Female		
Crimp	Machined	26-24	RM24W3K	RC24W3K	0.80	1.60
		22-20	RM20W3K	RC20W3K	1.15	1.60
		20-18	RM18W3K	RC18W3K	1.30	2.10
	Stamped & Formed reeled contacts <small>See note (2) for loose piece</small>	26-24	SM24W3TK6 <sup>(1)(2)</sup>	SC24W3TK6 <sup>(1)(2)</sup>	-	0.90-1.60
		26-24	SM24W3S26 <sup>(1)(2)</sup>	SC24W3S25 <sup>(1)(2)</sup>	-	0.90-1.60
		22-20	SM20W3TK6 <sup>(1)(2)</sup>	SC20W3TK6 <sup>(1)(2)</sup>	-	1.20-2.10
		22-20	SM20W3S26 <sup>(1)(2)</sup>	SC20W3S25 <sup>(1)(2)</sup>	-	1.20-2.10
#12						
Crimp	Machined	22	82911457NA	82911456A	0.87	4.90
		20	82911459NA	82911458A	1.12	
		18	82911461NA	82911460A	1.42	
		16	82911463NA	82911462A	1.72	
		14	82911465NA	82911464A	2.22	
		12	82911467NA	82911466A	2.82	

(1): Example of plating, for other plating see page 164

(2): Loose piece contact available if putting L. Example: SM20WL3TK6

Note: all dimensions are in mm

### Electrical Characteristics

**UL**  
20A 500V UL94 V-0

**CSA**  
18A 500V UL94 V-0

**IEC**  
25A 150V 2.5kV 3  
Temperature elevation: 50°C

### UTS 102W2 Derating Curves

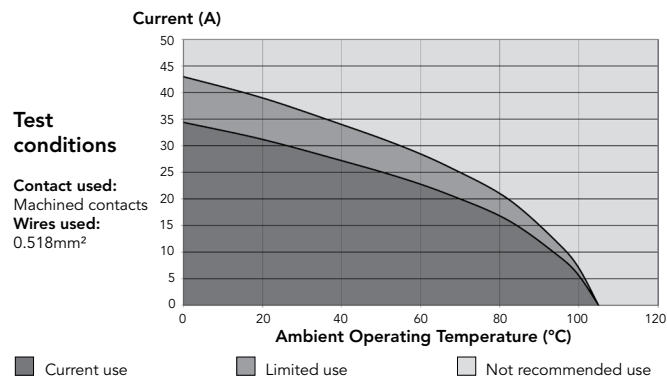

### 104 (Shell size 10, 4x#16)

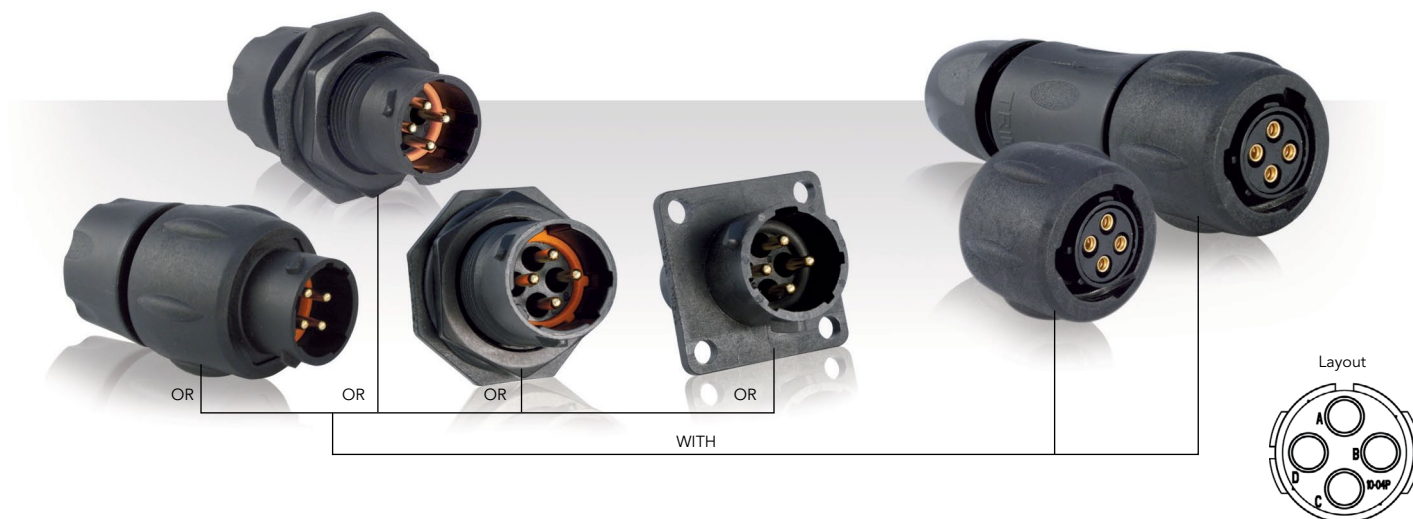

### Connector Part Numbers

Contact type	Connector type	Backshell	Part number	
			Male insert	Female insert
Crimp Contact supplied separately see page 71	Square flange receptacle	Without (Fig. 1)	<b>UTS0104P</b>	<b>UTS0104S</b>
	Free hanging receptacle	Cable gland and grommet (Fig. 2)	<b>UTS1GJC104P</b>	-
	Free hanging receptacle	Nut and grommet (Fig. 3)	<b>UTS1GN104P</b>	-
	Free hanging receptacle	Cable gland (Fig. 2)	<b>UTS1JC104P</b>	<b>UTS1JC104S</b>
	Plug	Without (Fig. 4)	<b>UTS6104P</b>	<b>UTS6104S</b>
	Plug	Cable gland and grommet (Fig. 5)	-	<b>UTS6GJC104S</b>
	Plug	Nut and grommet (Fig. 6)	-	<b>UTS6GN104S</b>
	Plug	Cable gland (Fig. 5)	<b>UTS6JC104P</b>	<b>UTS6JC104S</b>
	Jam nut receptacle	Without (Fig. 7)	<b>UTS7104P</b>	<b>UTS7104S</b>
	Jam nut receptacle	Cable gland and grommet (Fig. 9)	<b>UTS7GJC104P</b>	-
Jam nut receptacle	Nut and grommet (Fig. 8)	<b>UTS7GN104P</b>	-	
PCB contacts supplied separately see page 71	Jam nut receptacle	Without (Fig. 7)	<b>UTS7104P</b>	<b>UTS7104S</b>

Possibilities of discrimination/keying methods see page 208

### Overmoulded Cable Assembly Part Numbers

Overmoulding type	Connector type	Wire size (mm <sup>2</sup> )	Harmonized cable part number <sup>(1)</sup>	Part number (length: 1m.)*	
				Male plug	Female plug
Straight ending	Plug	1.5	H05 VV - F 4x1.5	<b>HAUTS0V104PST100</b>	<b>HAUTS0V104SST100</b>
Right angle ending	Plug	1.5	H05 VV - F 4x1.5	<b>HAUTS0V104PRA100</b>	<b>HAUTS0V104SRA100</b>

(1) Other cable available on demand

\* Other lengths available on demand

104 (Shell size 10, 4x#16)

Dimensions

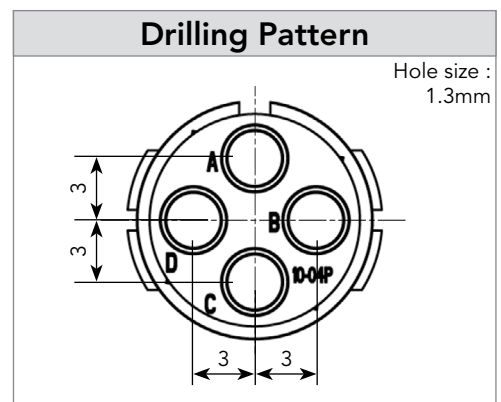
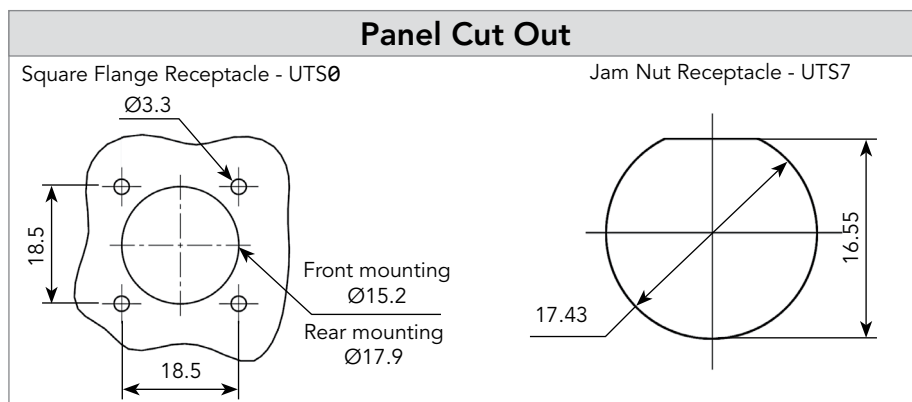
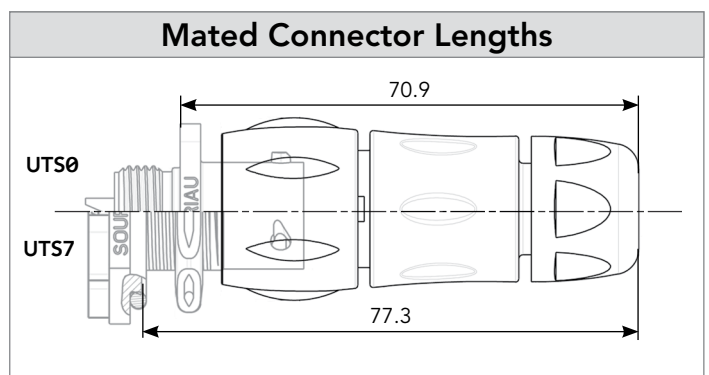
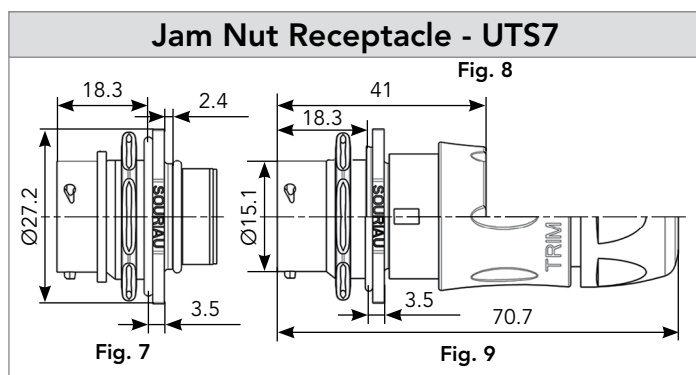
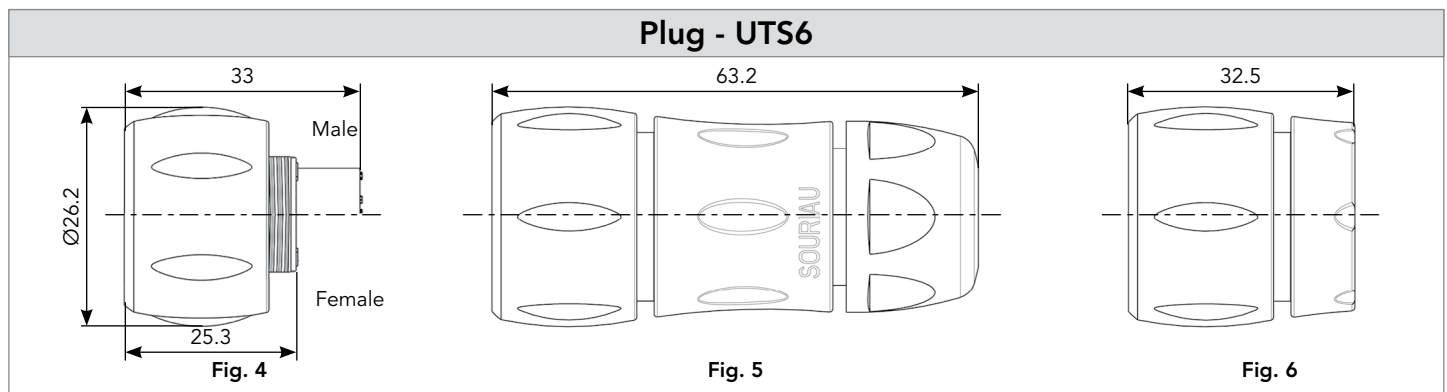
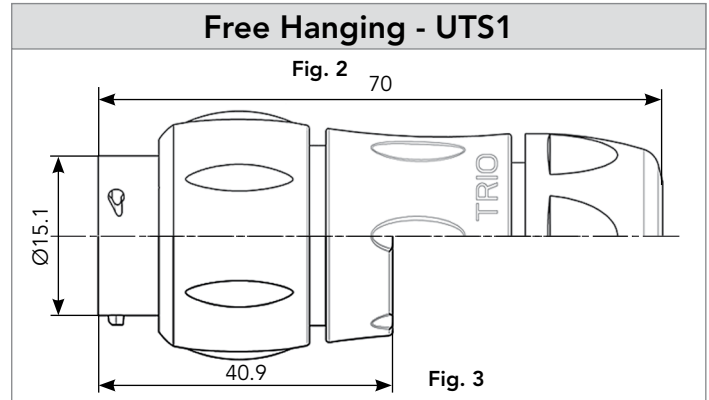
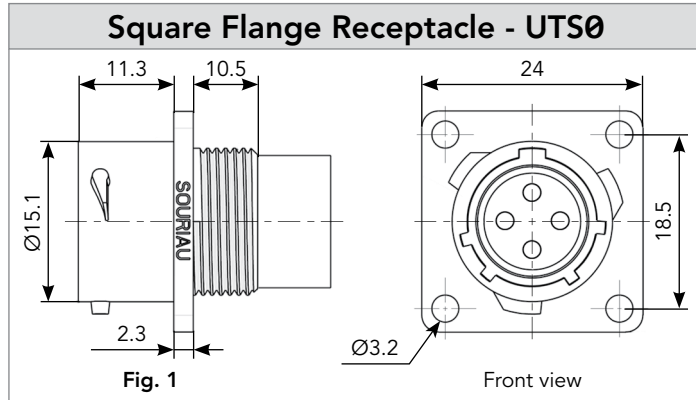

Note: Overmoulded cable assembly dimensions available page 179.

Note: all dimensions are in mm

104 (Shell size 10, 4x#16)

## Accessories and Tooling

### Jam Nut Sealing Caps



IP68/69K

Part number
UTS10DCG



IP68/69K Metal terminal

Part number
UTS10DCGR

### Handle (without Head)



Part number
SHANDLES

### Tool Kit



Part number
TOOLKIT

### Plug Sealing Cap



IP68/69K

Part number
UTS610DCG

### Square Flange Sealing Cap



IP68/69K Metal terminal

Part number
UTS10DCGE

### Crimp Tooling (without Shandles)



Contacts	Contact size	Part number of head
RM/RC 28M1K <sup>(1)</sup>	Standard contacts #16 Ø 1.6mm	S16RCM20*
RM/RC 24M9K <sup>(1)</sup>		S16RCM20*
RM/RC 20M13K <sup>(1)</sup>		S16RCM20*
RM/RC 20M12K <sup>(1)</sup>		S16RCM20*
RM/RC 16M23K <sup>(1)</sup>		S16RCM16*
RM/RC 14M30K <sup>(1)</sup>		S16RCM14*
SM/SC 24ML1TK6 <sup>(1)</sup>		S16SCM20*
SM/SC 20ML1TK6 <sup>(1)</sup>		S16SCM20*
SM/SC 16ML1TK6 <sup>(1)</sup>		S16SCML1*
SM/SC 14ML1TK6 <sup>(1)</sup>		S16SCML1*
SM/SC 16ML11TK6 <sup>(1)</sup>		S16SCML11*
RMDXK10D28K		Coaxial contacts
RCDXK1D28K		
RM/RC DX60xxD28K		
RM/RC DXK10D28 + yorK090		
RM/RC DX60xxD28		

(1): Example of plating, for other plating options see page 164  
\* Heads to be used with handle PN: SHANDLES

### Plastic Protective Cap



Part numbers	
Receptacle cap	Plug cap
85005586A	85005595

### Gasket



Part numbers
UTFD12B

### Color Coding Rings

G for Green 

Y for Yellow 

R for Red 

Part numbers	
Receptacles	Plugs
UTS710CCRR	UTS610CCRR
UTS710CCRY	UTS610CCRY
UTS710CCRG	UTS610CCRG



104 (Shell size 10, 4x#16)

Contacts

#16	Contact type	AWG	Part number		Max wire Ø	Max insulator Ø
			Male	Female		
Crimp	Machined	30-28	RM28M1K <sup>(1)</sup>	RC28M1K <sup>(1)</sup>	0.55	1.00
		26-24	RM24M9K <sup>(1)</sup>	RC24M9K <sup>(1)</sup>	0.80	1.60
		22-20	RM20M13K <sup>(1)</sup>	RC20M13K <sup>(1)</sup>	1.15	1.80
		22-20	RM20M12K <sup>(1)</sup>	RC20M12K <sup>(1)</sup>	1.15	2.20
		20-16	RM16M23K <sup>(1)</sup>	RC16M23K <sup>(1)</sup>	1.80	3.20
		16-14	RM14M30K <sup>(1)</sup>	RC14M30K <sup>(1)</sup>	2.30	3.20
	Stamped & Formed reeled contacts See note (2) for loose piece	26-24	SM24M1TK6 <sup>(1)(2)</sup>	SC24M1TK6 <sup>(1)(2)</sup>	-	0.90-1.60
		22-20	SM20M1TK6 <sup>(1)(2)</sup>	SC20M1TK6 <sup>(1)(2)</sup>	-	1.20-2.10
		18-16	SM16M1TK6 <sup>(1)(2)</sup>	SC16M1TK6 <sup>(1)(2)</sup>	-	3.20
		18-16	SM16M11TK6 <sup>(1)(2)</sup>	SC16M11TK6 <sup>(1)(2)</sup>	-	3.00
14		SM14M1TK6 <sup>(1)(2)</sup>	SC14M1TK6 <sup>(1)(2)</sup>	-	3.20	
PCB	Machined <sup>(3)</sup>	-	RM20M12E83K <sup>(1)</sup>	RC20M12E84K <sup>(1)</sup>	-	-
Coaxial	Cable Multipiece	see pages 167, 200 to 206	RMDXK10D28	RCDXK1D28	-	-
	Cable Monocrimp		RMDX60xxD28	RCDX60xxD28	-	-
	Twisted pair Multipiece		RMDXK10D28 + york090	RCDXK1D28 + york090	-	-
	Twisted pair Monocrimp		RMDX60xxD28	RCDX60xxD28	-	-
Fiber optic	POF contacts (Plastic Optical Fiber)	-	RMPOF1000	RCPOF1000B	-	-

(1): Example of plating, for other plating see page 164 (2): Loose piece contact available if putting L. Example: SM20ML1TK6 (3): For dimensions see page 168 Note: all dimensions are in mm

Electrical Characteristics
<p><b>UL</b> 10A 500V UL94 V-0</p> <p><b>CSA</b> 7A 500V UL94 V-0</p> <p><b>IEC</b> 13A 150V 2.5kV 3</p>

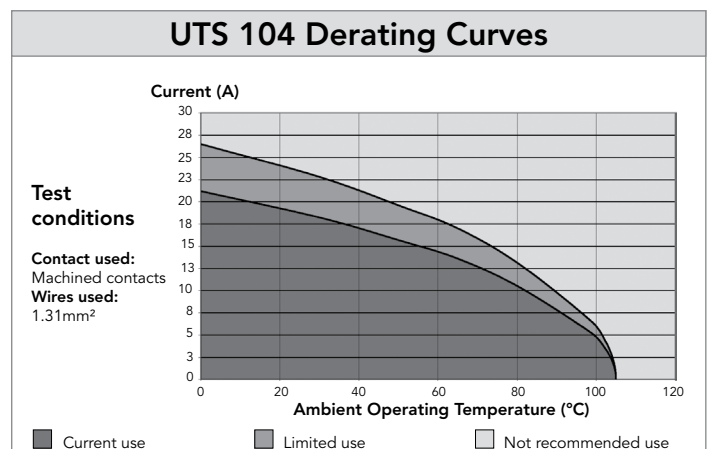

### 14E5/14D5 (Shell size 14, 5x#16)

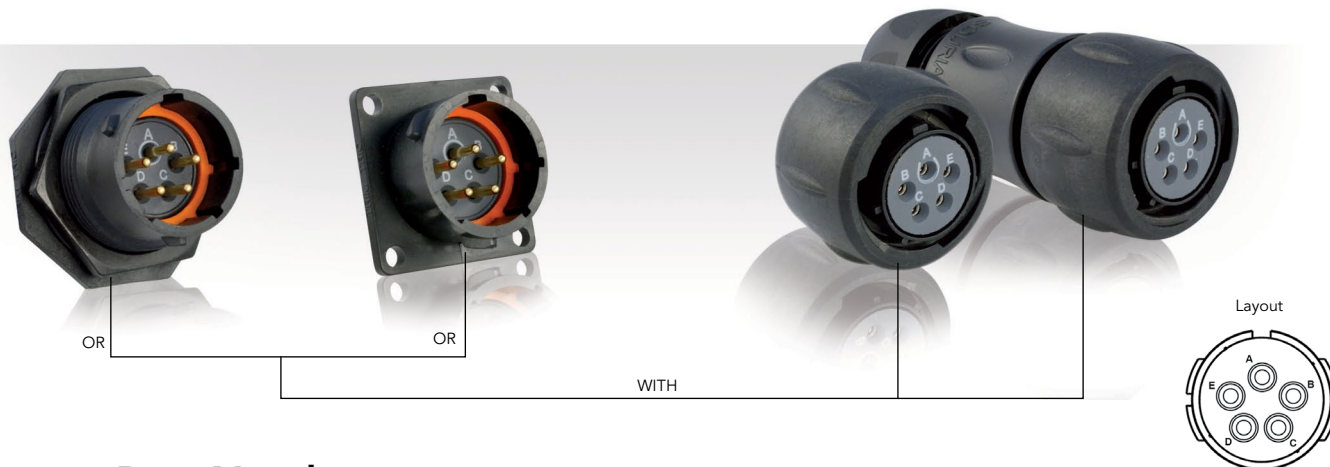

### Connector Part Numbers

Contact type	Connector type	Backshell	Part number	
			Male insert	Female insert
Hand solder electrical contacts loaded see page 75	Square flange receptacle	Without (Fig. 6)	<b>UTS014E5P</b>	<b>UTS014E5S</b>
	Plug	Without (Fig. 1)	<b>UTS614E5P</b>	<b>UTS614E5S</b>
		Cable gland (Fig. 2)	<b>UTS6JC14E5P</b>	<b>UTS6JC14E5S</b>
	Jam nut receptacle	Without (Fig. 3)	<b>UTS714E5P</b>	<b>UTS714E5S</b>
PCB contacts loaded see page 75	Square flange receptacle	Without (Fig. 6)	<b>UTS014D5P</b>	<b>UTS014D5S</b>
	Jam nut receptacle with hold down clips	Without (Fig. 4)	<b>UTS714D5P32</b>	<b>UTS714D5S32</b>
	Jam nut receptacle with stand off and without hold down clip	Without (Fig. 5)	<b>UTS714D5P</b>	<b>UTS714D5S</b>

Possibilities of discrimination/keying methods see page 208

Sealed unmated

### Overmoulded Cable Assembly Part Numbers

Overmoulding type	Connector type	Wire size (mm <sup>2</sup> )	Harmonized cable part number <sup>(1)</sup>	Part number (length: 1m.)*	
				Male plug	Female plug
Straight ending	Plug	1.5	H05 VV - F 5x1.5	<b>HAUTS0V14E5PST100</b>	<b>HAUTS0V14E5SST100</b>
Right angle ending	Plug	1.5	H05 VV - F 5x1.5	<b>HAUTS0V14E5PRA100</b>	<b>HAUTS0V14E5SRA100</b>

(1) Other cable available on demand

\* Other lengths available on demand



14E5/14D5 (Shell size 14, 5x#16)

Dimensions

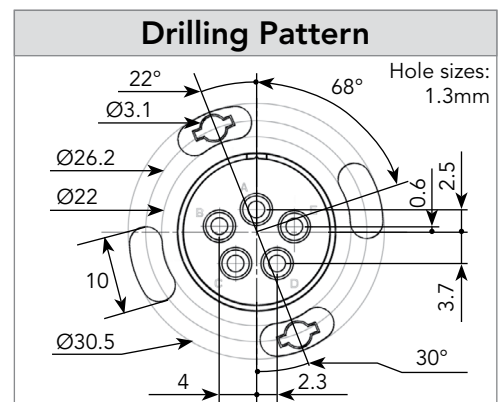
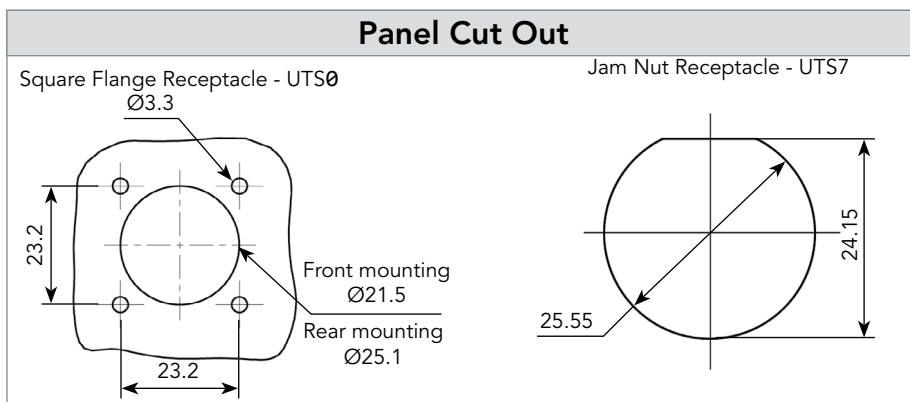
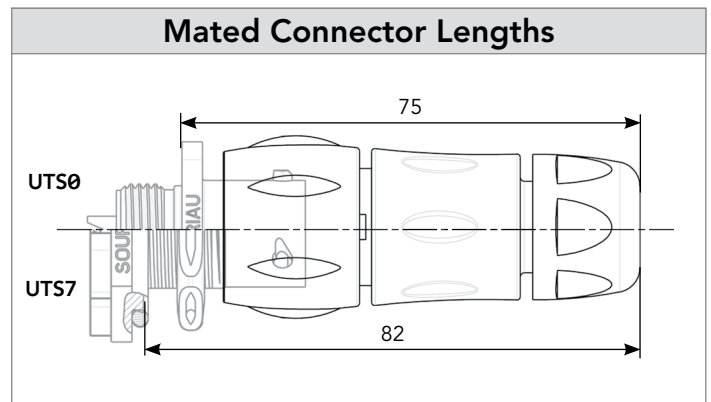
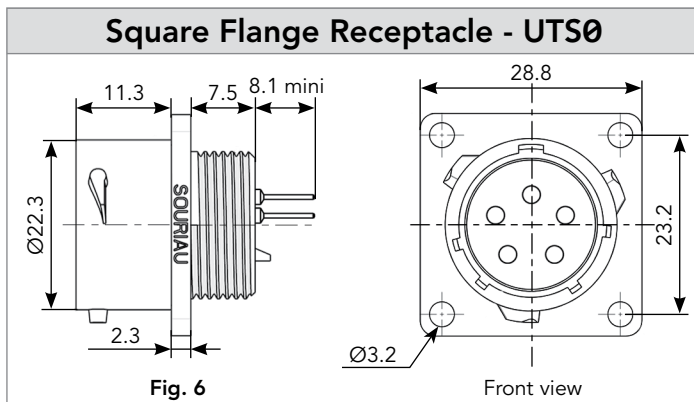
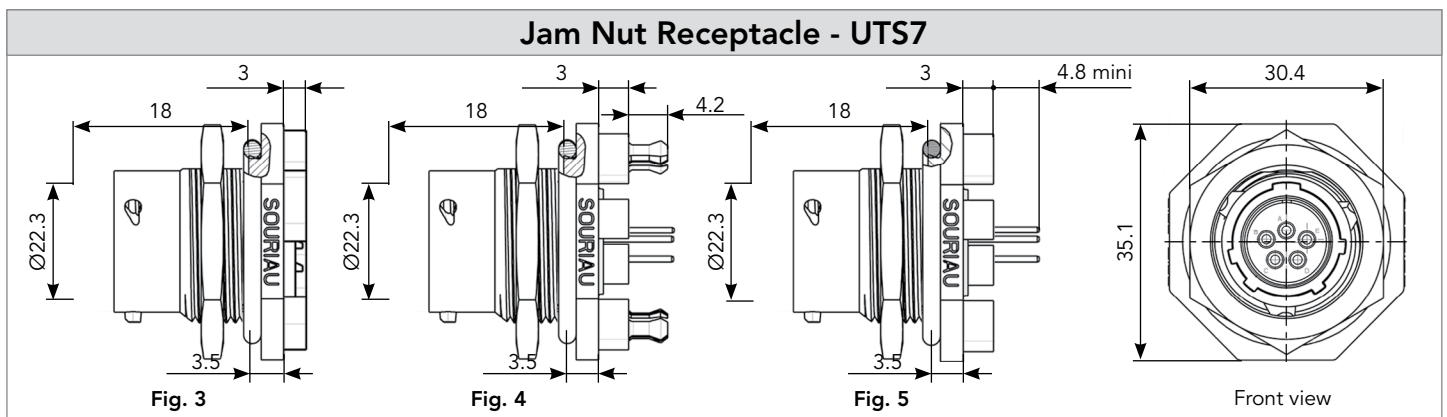
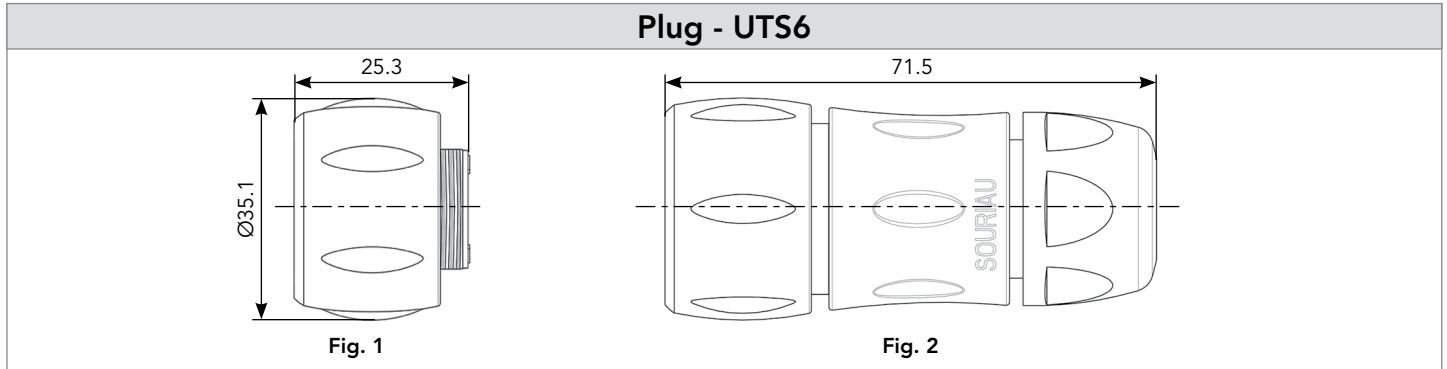

Note: Overmoulded cable assembly dimensions available page 179.

Note: all dimensions are in mm

## 14E5/14D5 (Shell size 14, 5x#16)

### Accessories and Tooling

#### Jam Nut Sealing Caps



IP68/69K

Part number
UTS14DCG



IP68/69K Metal terminal

Part number
UTS14DCGR

#### Plug Sealing Cap



IP68/69K

Part number
UTS614DCG

#### Square Flange Sealing Cap



IP68/69K Metal terminal

Part number
UTS14DCGE

#### Plastic Protective Cap



Part numbers	
Receptacle cap	Plug cap
85005588A	85005597

#### Gasket



Part numbers
UTFD14B

#### Color Coding Rings

G for Green 

Y for Yellow 

R for Red 

Part numbers	
Receptacles	Plugs
UTS714CCRR	UTS614CCRR
UTS714CCRY	UTS614CCRY
UTS714CCRG	UTS614CCRG

# 14E5/14D5 (Shell size 14, 5x#16)

## Contacts

#16	Contact type	Plating	Cable acceptance (AWG)	Wire stripping length
Hand solder	Loaded in the connector	Min 0.4μ gold over 0.8μ Ni	18 to 14	5 mm
PCB	Machined <sup>(1)</sup>	Min 0.4μ gold over 0.8μ Ni	-	-

(1): For dimensions see page 169

### Electrical Characteristics

**UL**  
12A 600V UL94 HB

**CSA**  
12A 600V UL94 HB

**IEC**  
16A 150V 2.5kV 3

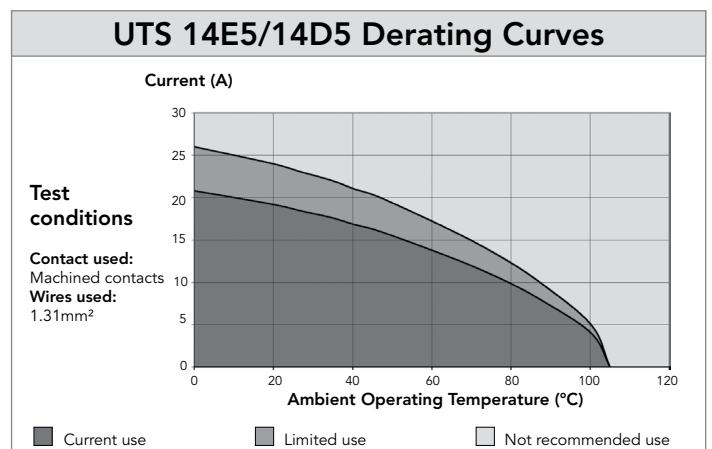

**18X2M3** (Shell size 18, 3x#16, 2x#8)



**Connector Part Numbers**

Contact type	Connector type	Backshell	Part number	
			Male insert	Female insert
Crimp contacts supplied separately see page 79	NPT threaded receptacle	Without (Fig. 1)	<b>UTS718X2M3PNPT</b>	<b>UTS718X2M3SNPT</b>
	Plug	Without (Fig. 2)	<b>UTS618X2M3P</b>	<b>UTS618X2M3S</b>
	Plug	Cable gland (Fig. 3)	<b>UTS6JC18X2M3P</b>	<b>UTS6JC18X2M3S</b>
PCB contacts supplied separately see page 79	NPT threaded receptacle	Without (Fig. 1)	<b>UTS718X2M3PNPT</b>	<b>UTS718X2M3SNPT</b>

**18X2M3** (Shell size 18, 3x#16, 2x#8)

**Dimensions**

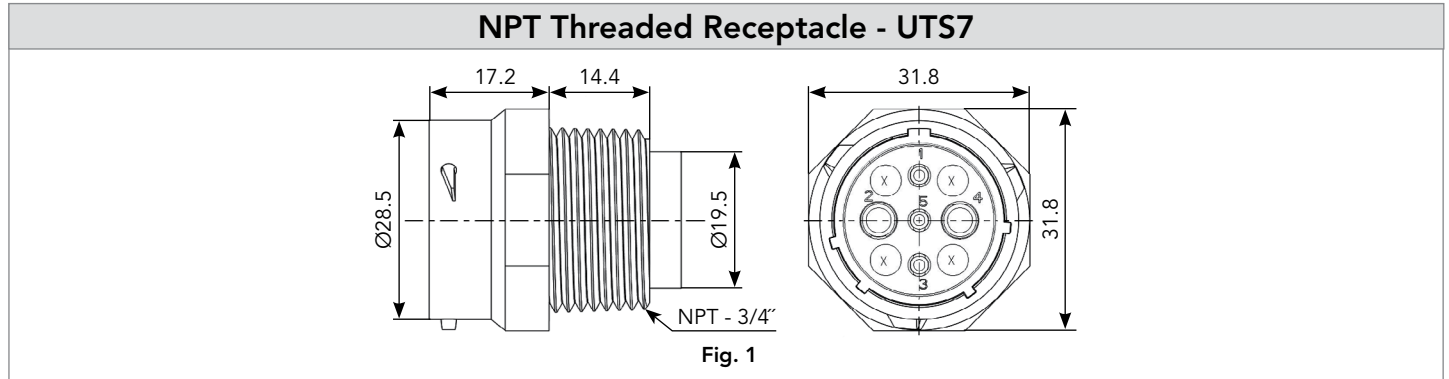

5

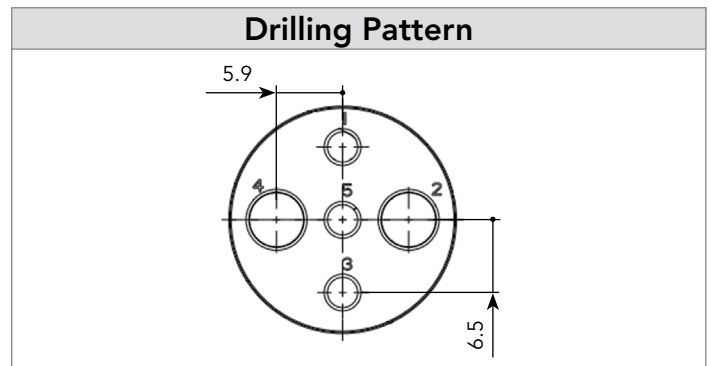
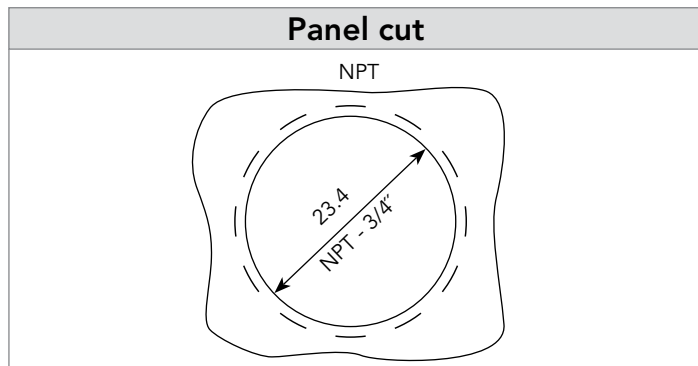
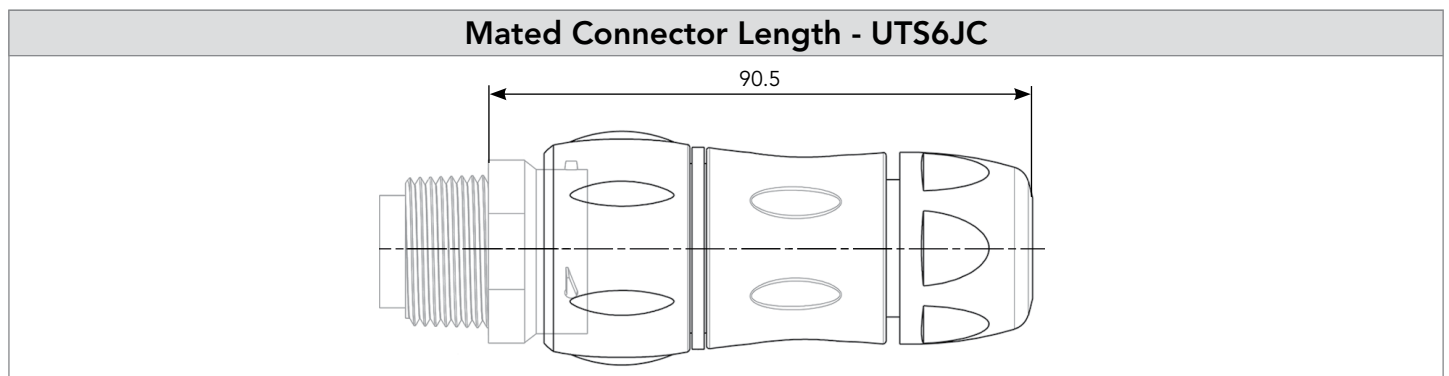
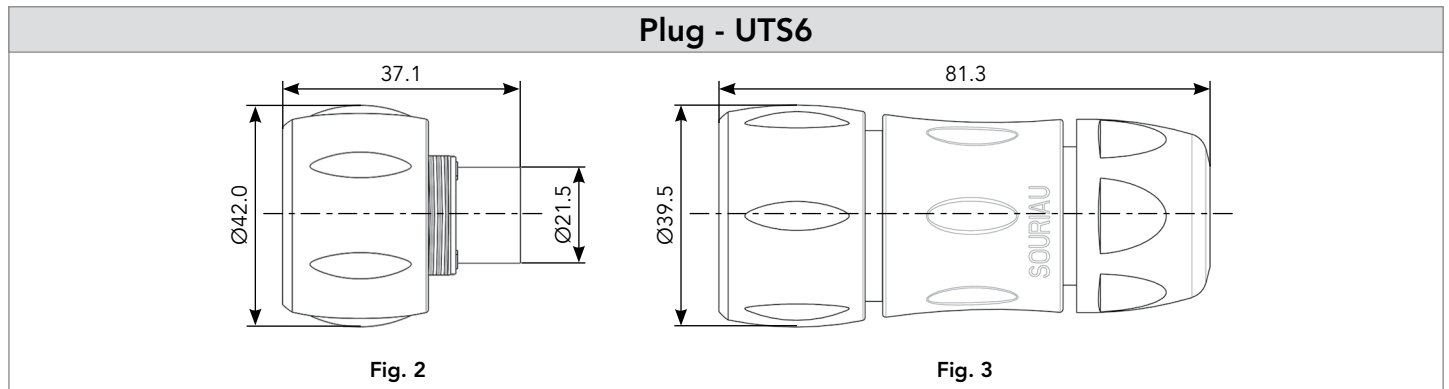

Note: all dimensions are in mm

# 18X2M3 (Shell size 18, 3x#16, 2x#8)

## Accessories and Tooling

### Jam Nut or NPT Threaded Receptacle Sealing Caps



IP68/69K

Part number  
UTS18DCG



IP68/69K Metal terminal

Part number  
UTS18DCGR

### Plug Sealing Cap



IP68/69K

Part number  
UTS618DCG

### Extraction Tool #16



Part number  
RX2025GE1

### Plastic Protective Cap



#### Part numbers

Receptacle cap	Plug cap
85005590A	85005599

### Color Coding Rings

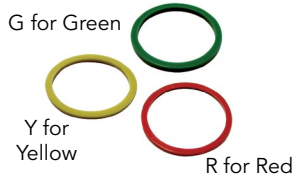

Part numbers	
Receptacles	Plugs
UTS718CCRR	UTS618CCRR
UTS718CCRY	UTS618CCRY
UTS718CCRG	UTS618CCRG

### Crimp Tooling #16



Part number  
SHANDLES



Part number  
TOOLKIT



Contacts	Contact size	Part number of head
RM/RC 28M1K	Standard contacts #16 Ø 1.6mm	S16RCM20*
RM/RC 24M9K		S16RCM20*
RM/RC 20M13K		S16RCM20*
RM/RC 20M12K		S16RCM20*
RM/RC 16M23K		S16RCM16*
RM/RC 14M30K		S16RCM14*
SM/SC 24ML1TK6 <sup>(1)</sup>		S16SCM20*
SM/SC 20ML1TK6 <sup>(1)</sup>		S16SCM20*
SM/SC 16ML1TK6 <sup>(1)</sup>		S16SCML1*
SM/SC 14ML1TK6 <sup>(1)</sup>		S16SCML1*
SM/SC 16ML11TK6 <sup>(1)</sup>		S16SCML11*

(1): Example of plating, for other plating see page 164  
\*: Heads to be used with handle PN: SHANDLES

### Crimp Tooling #8



Part number hand tool  
M317



Part number positioner + locator setting  
VGE10078A

### Extraction Tool #8



Part number extraction tool  
51060210936

# 18X2M3 (Shell size 18, 3x#16, 2x#8)

## Contacts

#16	Contact type	Wire size		Part number		Max wire Ø	Max insulator Ø
		AWG	mm <sup>2</sup>	Male	Female		
Crimp	Machined	30-28	0.50-0.08	RM28M1K	RC28M1K	0.55	1.00
		26-24	0.13-0.25	RM24M9K	RC24M9K	0.80	1.60
		22-20	0.32-0.52	RM20M13K	RC20M13K	1.15	1.80
		22-20	0.32-0.52	RM20M12K	RC20M12K	1.15	2.20
		20-16	0.52-1.50	RM16M23K	RC16M23K	1.80	3.20
		16-14	1.50-2.50	RM14M30K	RC14M30K	2.30	3.20
	Stamped & Formed reeled contacts See note (2) for loose piece	26-24	0.13-0.25	SM24M1TK6 <sup>(1)(2)</sup>	SC24M1TK6 <sup>(1)(2)</sup>	-	0.90-1.60
		22-20	0.32-0.52	SM20M1TK6 <sup>(1)(2)</sup>	SC20M1TK6 <sup>(1)(2)</sup>	-	1.20-2.10
		18-16	0.80-1.50	SM16M1TK6 <sup>(1)(2)</sup>	SC16M1TK6 <sup>(1)(2)</sup>	-	3.20
		18-16	0.80-1.50	SM16M11TK6 <sup>(1)(2)</sup>	SC16M11TK6 <sup>(1)(2)</sup>	-	3.00
14		2.50	SM14M1TK6 <sup>(1)(2)</sup>	SC14M1TK6 <sup>(1)(2)</sup>	-	3.20	
PCB	Machined <sup>(3)</sup>	-	-	RM20M12E83K <sup>(1)</sup>	RC20M12E84K <sup>(1)</sup>	-	-
Coaxial	Cable Multipiece	-	-	RMDXK10D28	RCDXK1D28	-	-
	Cable Monocrimp	-	-	RMDX60xxD28	RCDX60xxD28	-	-
	Twisted pair Multipiece	-	-	RMDXK10D28 + york090	RCDXK1D28 + york090	-	-
	Twisted pair Monocrimp	-	-	RMDX60xxD28	RCDX60xxD28	-	-
Fiber optic	POF contacts (Plastic Optical Fiber)	-	-	RMPOF1000	RCPOF1000B	-	-
#8							
Crimp	Machined	16	1.50	82913601A <sup>(1)</sup>	82913600A <sup>(1)</sup>	1.72	6.50
		14	2.50	82913603A <sup>(1)</sup>	82913602A <sup>(1)</sup>	2.22	
		12	4.00	82913605A <sup>(1)</sup>	82913604A <sup>(1)</sup>	2.82	
		10	6.00	82913607A <sup>(1)</sup>	82913606A <sup>(1)</sup>	3.50	
		8	10.00	82913609A <sup>(1)</sup>	82913608A <sup>(1)</sup>	4.35	
PCB	Machined <sup>(3)</sup>	-	-	82911685NPC <sup>(1)</sup>	82911684NPC <sup>(1)</sup>	-	-

(1): Example of plating, for other plating see page 164 (2): Loose piece contact available if putting L. Example: SM20ML1TK6 (3): For dimensions see page 168 Note: all dimensions are in mm

### Electrical Characteristics

**UL**  
44A 600V UL94 V-0

**CSA**  
34A 600V UL94 V-0

**IEC**  
32A 300V 4kV 3

### UTS 18X2M3 Derating Curves

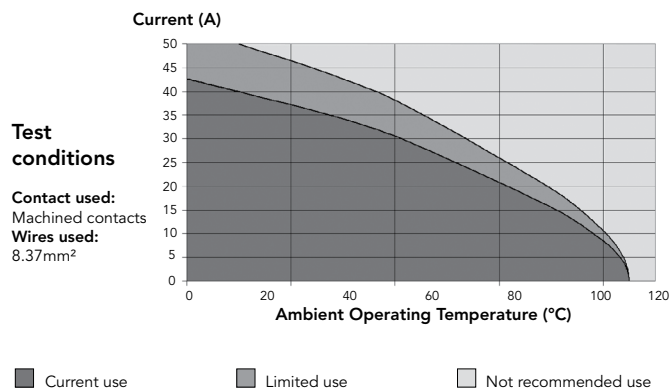

**103W3** (Shell size 10, 3x#20, 3x#16)

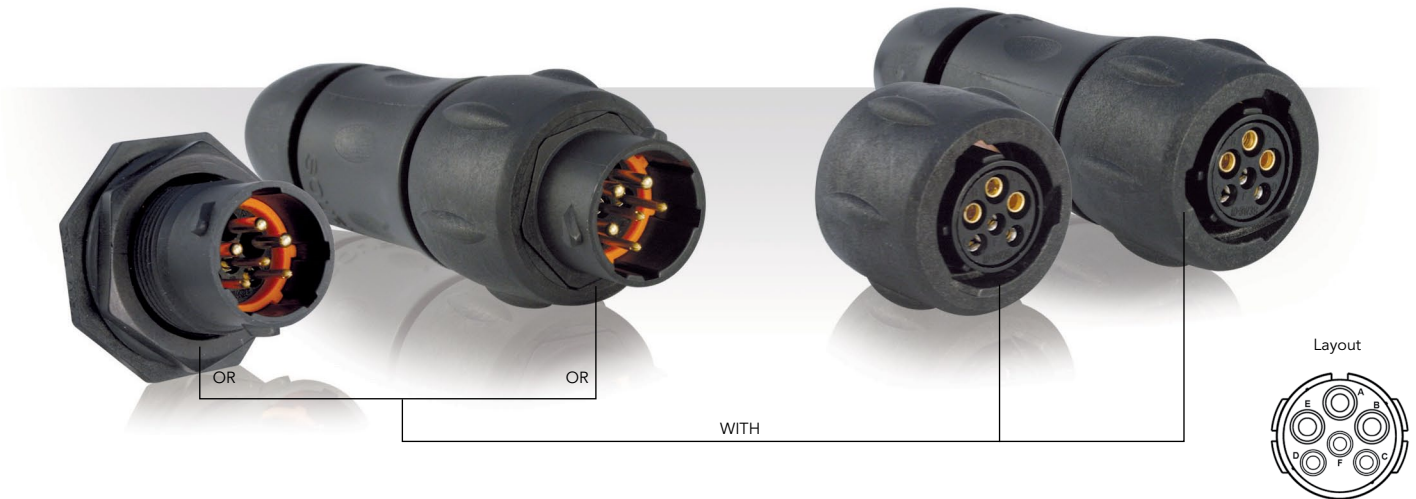

**Connector Part Numbers**

Contact type	Connector type	Backshell	Part number	
			Male insert	Female insert
Crimp contacts supplied separately see page 83	Free hanging receptacle	Cable gland (Fig. 1)	<b>UTS1JC103W3P</b>	<b>UTS1JC103W3S</b>
	Plug	Without (Fig. 2)	<b>UTS6103W3P</b>	<b>UTS6103W3S</b>
	Plug	Cable gland (Fig. 3)	<b>UTS6JC103W3P</b>	<b>UTS6JC103W3S</b>
	Jam nut receptacle	Without (Fig. 4)	<b>UTS7103W3P</b>	<b>UTS7103W3S</b>
PCB contacts supplied separately see page 83	Jam nut receptacle with stand off and without hold down clip	Without (Fig. 4)	<b>UTS7103W3P</b>	<b>UTS7103W3S</b>



103W3 (Shell size 10, 3x#20, 3x#16)

Dimensions

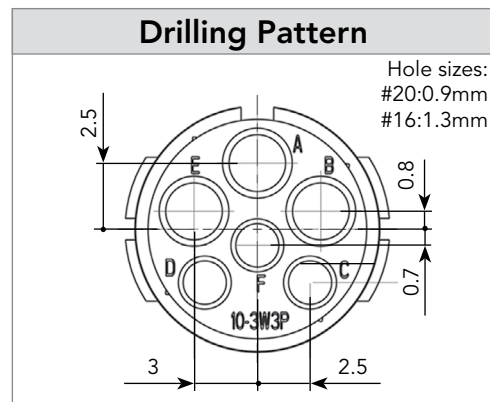
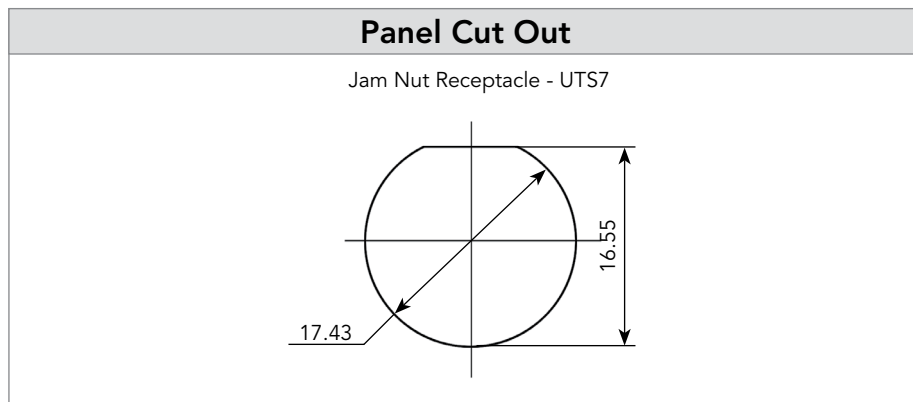
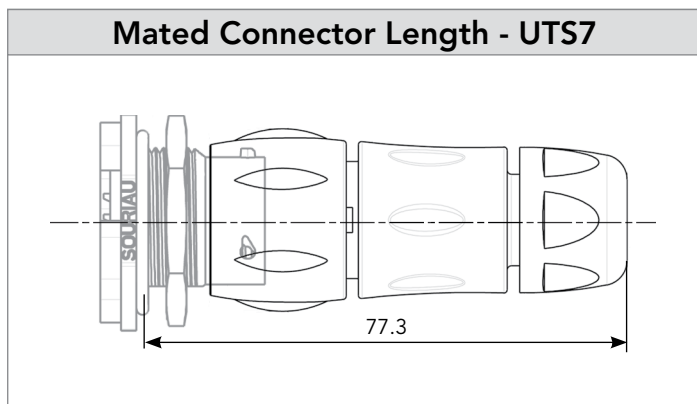
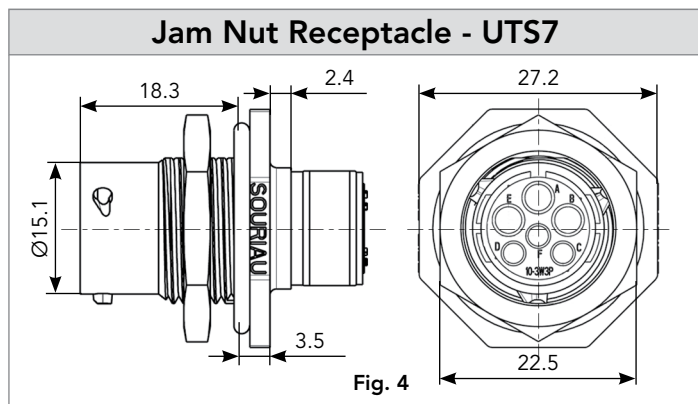
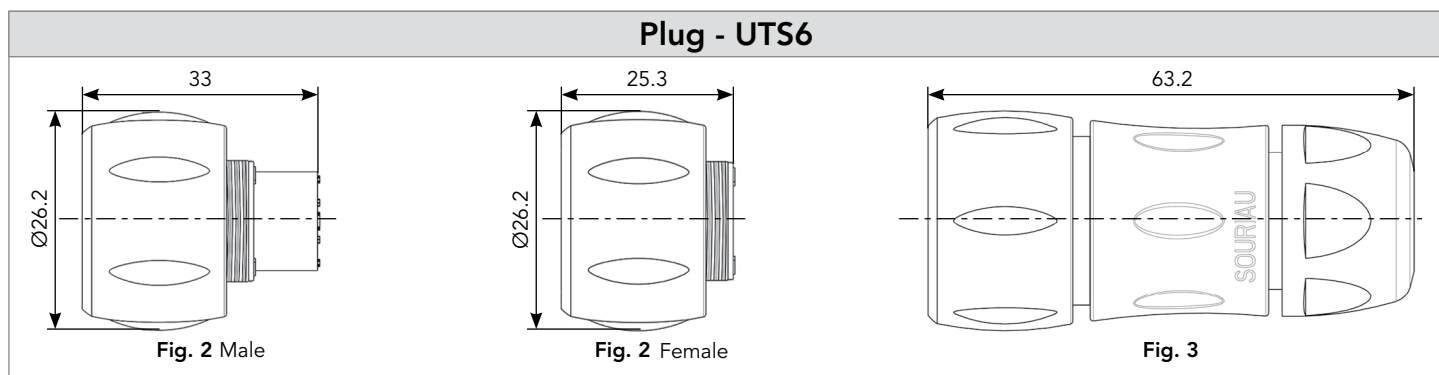
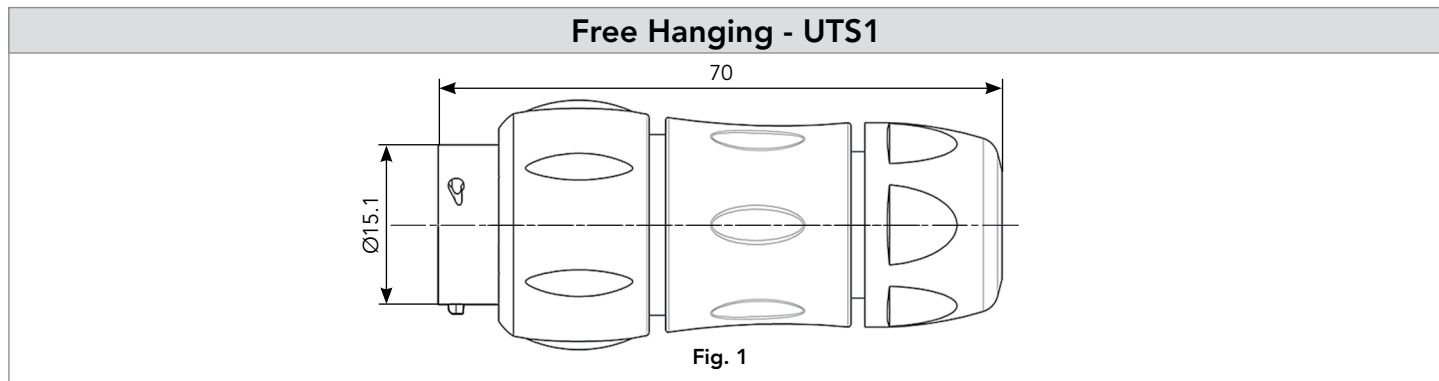

Note: all dimensions are in mm

# 103W3 (Shell size 10, 3x#20, 3x#16)

## Accessories and Tooling

### Jam Nut Sealing Caps



IP68/69K

Part number
UTS10DCG



IP68/69K Metal terminal

Part number
UTS10DCGR

### Handle



Part number
SHANDLES

### Tool Kit



Part number
TOOLKIT

### Plug Sealing Cap



IP68/69K

Part number
UTS610DCG

### Square Flange Sealing Cap



IP68/69K Metal terminal

Part number
UTS10DCGE

### Plastic Protective Cap



Part numbers	
Receptacle cap	Plug cap
85005586A	85005595

### Gasket



Part numbers
UTFD12B

### Color Coding Rings

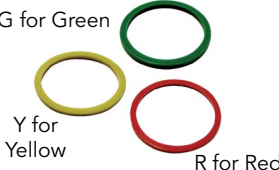

G for Green  
Y for Yellow  
R for Red

Part numbers	
Receptacles	Plugs
UTS710CCRR	UTS610CCRR
UTS710CCRY	UTS610CCRY
UTS710CCRG	UTS610CCRG

### Crimp Tooling



Contacts	Contact size	Part number of head	
RM/RC 28M1K	Standard contacts #16 Ø 1.6mm	S16RCM20*	
RM/RC 24M9K		S16RCM20*	
RM/RC 20M13K		S16RCM20*	
RM/RC 20M12K		S16RCM20*	
RM/RC 16M23K		S16RCM16*	
RM/RC 14M30K		S16RCM14*	
SM/SC 24ML1TK6 <sup>(1)</sup>		S16SCM20*	
SM/SC 20ML1TK6 <sup>(1)</sup>		S16SCM20*	
SM/SC 16ML1TK6 <sup>(1)</sup>		S16SCML1*	
SM/SC 14ML1TK6 <sup>(1)</sup>		S16SCML1*	
SM/SC 16ML11TK6 <sup>(1)</sup>		S16SCML11*	
RMDXK10D28		Coaxial contacts	M10S1J with die set & stop bushing see page 200 to 204
RCDXK1D28			
RMDX60xxD28			
RCDX60xxD28			
RM/RC DXK10D28 + york090	Standard contacts #20 Ø 1mm	S20RCM*	
RM/RC 24W3K <sup>(1)</sup>		S20RCM*	
RM/RC 20W3K <sup>(1)</sup>		S20RCM*	
SM/SC 24WL3S		S20SCM20*	
SM/SC 20WL3S		S20SCM20*	

(1): Example of plating, for other plating see page 164  
\*: Heads to be used with handle PN: SHANDLES

# 103W3 (Shell size 10, 3x#20, 3x#16)

## Contacts

#16	Contact type	Wire size		Part number		Max wire Ø	Max insulator Ø
		AWG	mm <sup>2</sup>	Male	Female		
Crimp	Machined	30-28	0.50-0.08	RM28M1K	RC28M1K	0.55	1.00
		26-24	0.13-0.25	RM24M9K	RC24M9K	0.80	1.60
		22-20	0.32-0.52	RM20M13K	RC20M13K	1.15	1.80
		22-20	0.32-0.52	RM20M12K	RC20M12K	1.15	2.20
		20-16	0.52-1.50	RM16M23K	RC16M23K	1.80	3.20
	Stamped & Formed reeled contacts <small>See note (2) for loose piece</small>	16-14	1.50-2.50	RM14M30K	RC14M30K	2.30	3.20
		26-24	0.13-0.25	SM24M1TK6 <sup>(1)(2)</sup>	SC24M1TK6 <sup>(1)(2)</sup>	-	0.90-1.60
		22-20	0.32-0.52	SM20M1TK6 <sup>(1)(2)</sup>	SC20M1TK6 <sup>(1)(2)</sup>	-	1.20-2.10
		18-16	0.80-1.50	SM16M1TK6 <sup>(1)(2)</sup>	SC16M1TK6 <sup>(1)(2)</sup>	-	3.20
		18-16	0.80-1.50	SM16M11TK6 <sup>(1)(2)</sup>	SC16M11TK6 <sup>(1)(2)</sup>	-	3.00
	14	2.50	SM14M1TK6 <sup>(1)(2)</sup>	SC14M1TK6 <sup>(1)(2)</sup>	-	3.20	
PCB	Machined <sup>(3)</sup>	-	-	RM20M12E83K <sup>(1)</sup>	RC20M12E84K <sup>(1)</sup>	-	-
Coaxial	Cable Multipiece	-	-	RMDXK10D28	RCDXK1D28	-	-
	Cable Monocrimp	-	-	RMDX60xxD28	RCDX60xxD28	-	-
	Twisted pair Multipiece	-	-	RMDXK10D28 + york090	RCDXK1D28 + york090	-	-
	Twisted pair Monocrimp	-	-	RMDX60xxD28	RCDX60xxD28	-	-
Fiber optic	POF contacts (Plastic Optical Fiber)	-	-	RMPOF1000	RCPOF1000B	-	-
#20							
Crimp	Machined	26-24	0.13-0.25	RM24W3K <sup>(1)</sup>	RC24W3K <sup>(1)</sup>	0.80	1.60
		22-20	0.32-0.52	RM20W3K <sup>(1)</sup>	RC20W3K <sup>(1)</sup>	1.15	1.60
		20-18	0.50-0.93	RM18W3K <sup>(1)</sup>	RC18W3K <sup>(1)</sup>	1.30	2.10
	Stamped & Formed reeled contacts <small>See note (2) for loose piece</small>	26-24	0.13-0.25	SM24W3TK6 <sup>(2)</sup>	SC24W3TK6 <sup>(2)</sup>	-	0.90-1.60
		26-24	0.13-0.25	SM24W3S26 <sup>(2)</sup>	SC24W3S25 <sup>(2)</sup>	-	0.90-1.60
		22-20	0.32-0.52	SM20W3TK6 <sup>(2)</sup>	SC20W3TK65 <sup>(2)</sup>	-	1.20-2.10
		22-20	0.32-0.52	SM20W3S26 <sup>(2)</sup>	SC20W3S25 <sup>(2)</sup>	-	1.20-2.10
PCB	Machined <sup>(3)</sup>	-	-	RMW5016K	RCW5016K	-	-

(1): Example of plating, for other plating see page 164 (2): Loose piece contact available if putting L. Example: SM20ML1TK6 (3): For dimensions see page 168 Note: all dimensions are in mm

Electrical Characteristics	
UL	10A 500V UL94 V-0
CSA	7A 500V UL94 V-0
IEC	5A 32V 1.5kV 3
Temperature elevation: 50°C	

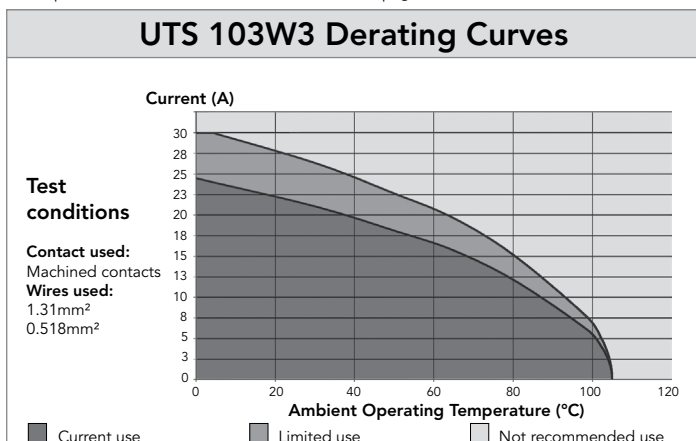

## 106 - 10E6/10D6 (Shell size 10, 6x#20)

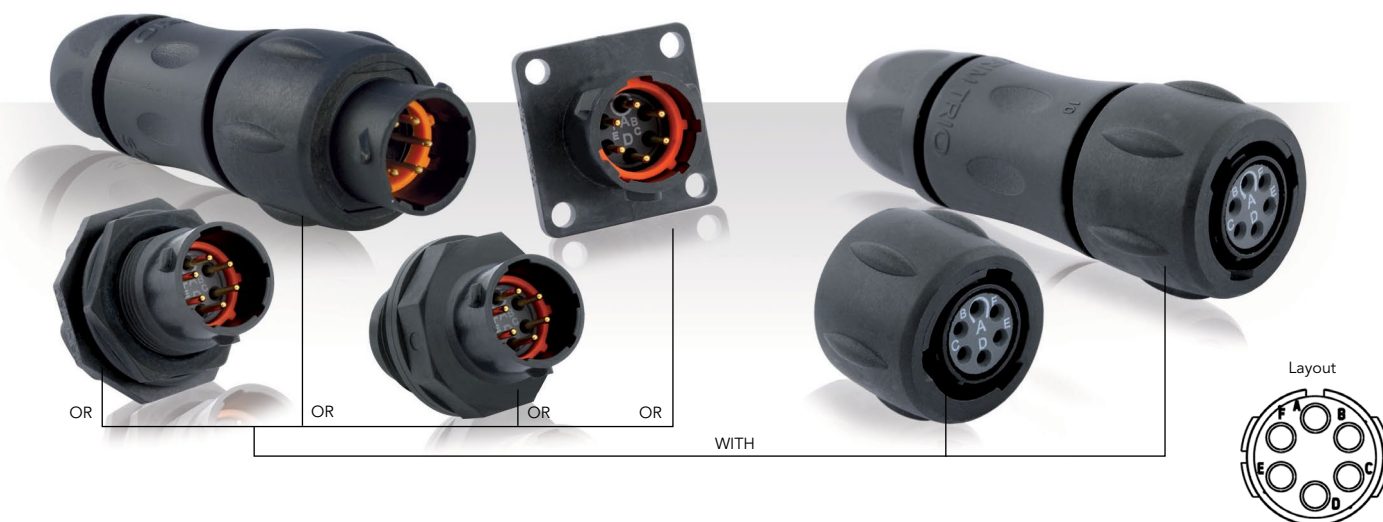

### Connector Part Numbers

Contact type	Connector type	Backshell	Part number	
			Male insert	Female insert
Crimp contacts supplied separately see page 87	Free hanging receptacle	Cable gland (Fig. 1)	<b>UTS1JC106P</b>	<b>UTS1JC106S</b>
	Plug	Without (Fig. 2)	<b>UTS6106P</b>	<b>UTS6106S</b>
	Plug	Cable gland (Fig. 3)	<b>UTS6JC106P</b>	<b>UTS6JC106S</b>
	Jam nut receptacle	Without (Fig. 4)	<b>UTS7106P</b>	<b>UTS7106S</b>
PCB contacts supplied separately see page 87	Jam nut receptacle	Without (Fig. 4)	<b>UTS7106P</b>	<b>UTS7106S</b>
Hand solder electrical contacts loaded	Square flange receptacle	Without (Fig. 10)	<b>UTS010E6P</b>	<b>UTS010E6S</b>
	Plug	Without (Fig. 2)	<b>UTS610E6P</b>	<b>UTS610E6S</b>
		Cable gland (Fig. 3)	<b>UTS6JC10E6P</b>	<b>UTS6JC10E6S</b>
Jam nut receptacle	Without (Fig. 5)	<b>UTS710E6P</b>	<b>UTS710E6S</b>	
Hand solder electrical contacts loaded see page 87	M16 threaded receptacle	Without (Fig. 8)	<b>UTS710E6PM16</b>	<b>UTS710E6SM16</b>
PCB contacts supplied separately see page 87	Jam nut receptacle	Without (Fig.4)	<b>UTS7106P</b>	<b>UTS7106S</b>
PCB contacts loaded see page 87	Square flange receptacle	Without (Fig.9)	<b>UTS010D6P</b>	<b>UTS010D6S</b>
	Jam nut receptacle with stand off and with hold down clips	Without (Fig.7)	<b>UTS710D6P32</b>	<b>UTS710D6S32</b>
	Jam nut receptacle with stand off and without hold down clip	Without (Fig.6)	<b>UTS710D6P</b>	<b>UTS710D6S</b>

Possibilities of discrimination/keying methods see page 208

Sealed unmatd

### Overmoulded Cable Assembly Part Numbers

Overmoulding type	Connector type	Wire size (mm <sup>2</sup> )	Harmonized cable part number <sup>(1)</sup>	Part number (length: 1m.)*	
				Male plug	Female plug
Straight ending	Plug	0.5	H05 VV - F 6x0.5	<b>HAUTS0V106PST100</b>	<b>HAUTS0V106SST100</b>
				<b>HAUTS0V10E6PST100</b>	<b>HAUTS0V10E6SST100</b>
Right angle ending	Plug	0.5	H05 VV - F 6x0.5	<b>HAUTS0V106PRA100</b>	<b>HAUTS0V106SRA100</b>
				<b>HAUTS0V10E6PRA100</b>	<b>HAUTS0V10E6SRA100</b>

(1) Other cable available on demand

\* Other lengths available on demand

106 - 10E6/10D6 (Shell size 10, 6x#20)

Dimensions

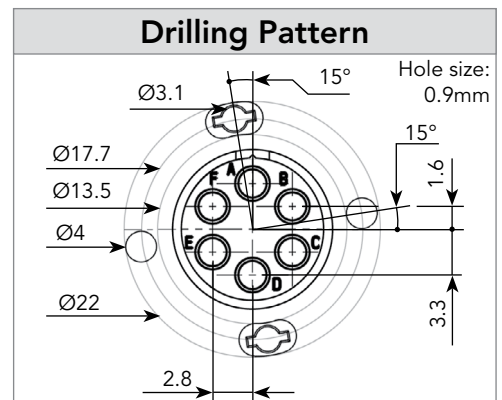
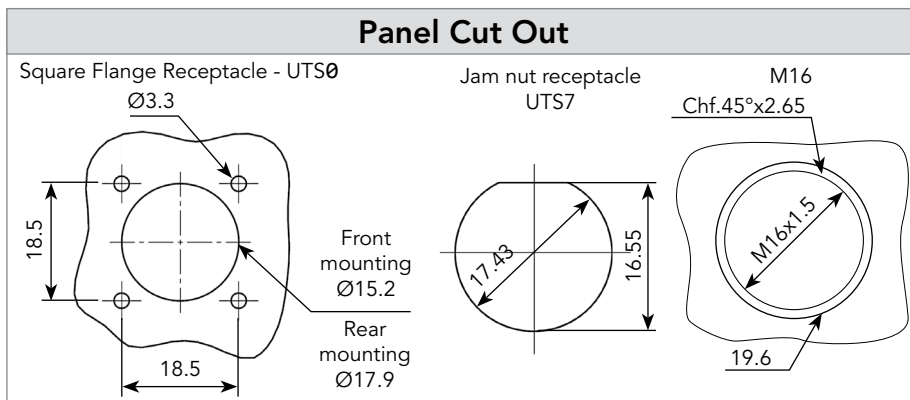
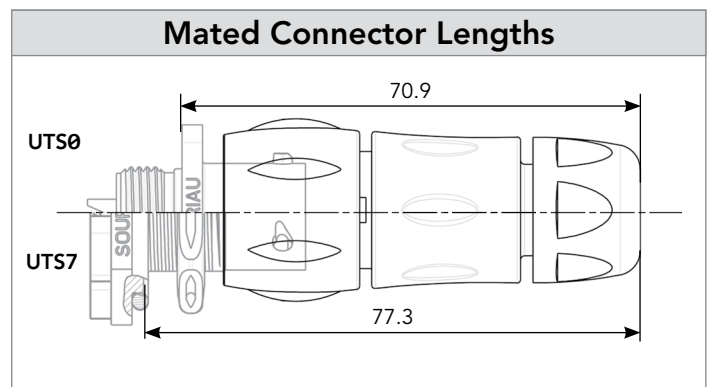
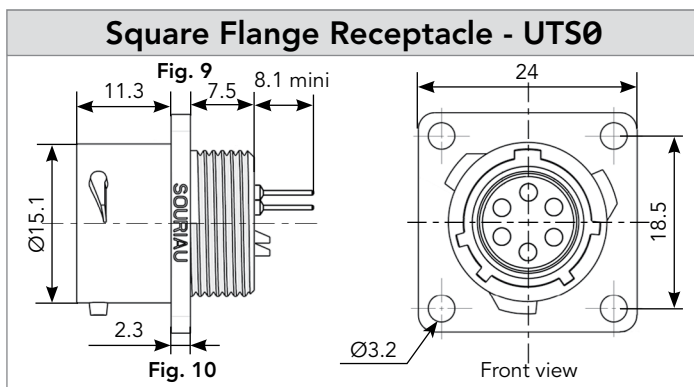
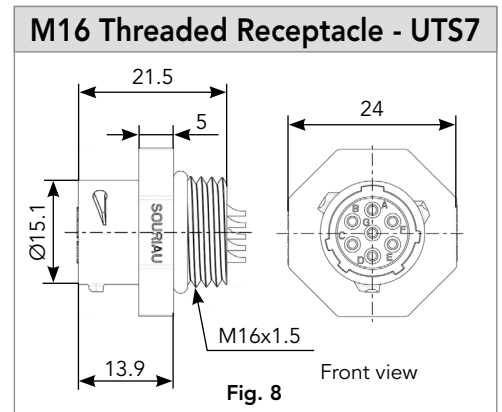
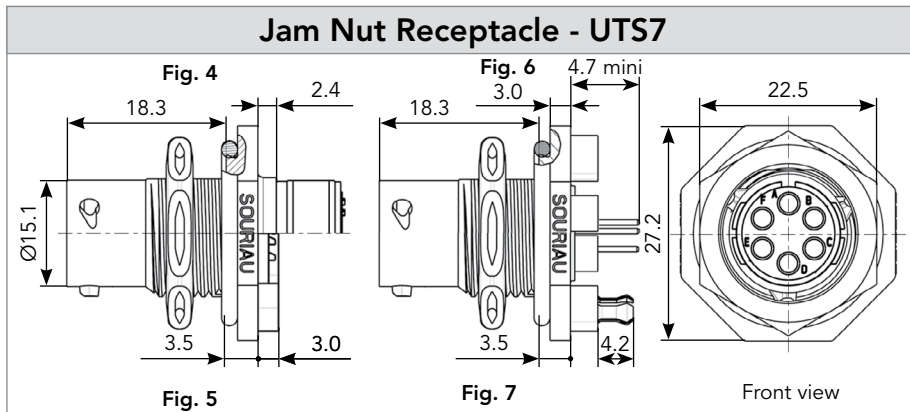
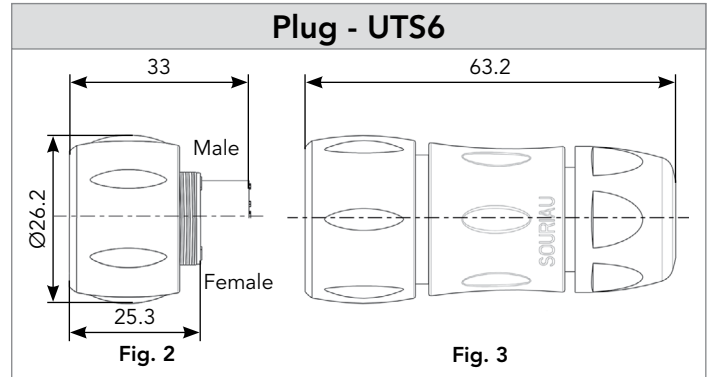
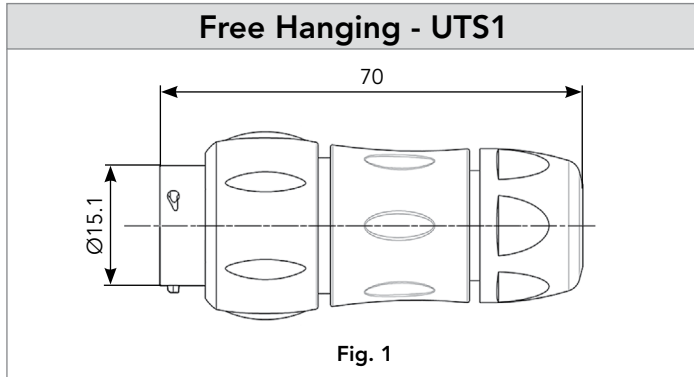

Note: Overmoulded cable assembly dimensions available page 179.

Note: all dimensions are in mm

# 106 - 10E6/10D6 (Shell size 10, 6x#20)

## Accessories and Tooling

### Jam Nut Sealing Caps



IP68/69K

Part number
UTS10DCG



IP68/69K Metal terminal

Part number
UTS10DCGR

### Handle (without Head)



Part number
SHANDLES

### Tool Kit



Part number
TOOLKIT

### Plug Sealing Cap



IP68/69K

Part number
UTS610DCG

### Square Flange Sealing Cap



IP68/69K Metal terminal

Part number
UTS10DCGE

### Crimp Tooling (without Shandles)



Contacts	Contact size	Part number of head
RM/RC 24W3K <sup>(1)</sup>	Standard contacts #20 Ø 1mm	S20RCM*
RM/RC 20W3K <sup>(1)</sup>		S20RCM*
RM/RC 18W3K <sup>(1)</sup>		S20RCM*
SM/SC 24WL3S		S20SCM20*
SM/SC 20WL3S		S20SCM20*

(1): Example of plating, for other plating see page 164  
\*: Heads to be used with handle PN: SHANDLES

### Plastic Protective Cap



Part numbers	
Receptacle cap	Plug cap
85005586A	85005595

### Gasket



Part numbers
UTFD12B

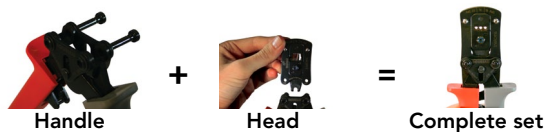

### Color Coding Rings

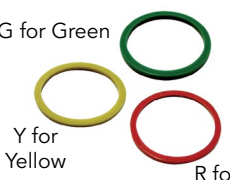

G for Green  
Y for Yellow  
R for Red

Part numbers	
Receptacles	Plugs
UTS710CCRR	UTS610CCRR
UTS710CCRY	UTS610CCRY
UTS710CCRG	UTS610CCRG

### Extraction Tool #20



Part number
RX20D44

# 106 - 10E6/10D6 (Shell size 10, 6x#20)

## Contacts

#20	Contact type	Wire size		Part number		Max wire Ø	Max insulator Ø
		AWG	mm <sup>2</sup>	Male	Female		
Crimp	Machined	26-24	0.13-0.25	RM24W3K <sup>(1)</sup>	RC24W3K <sup>(1)</sup>	0.80	1.60
		22-20	0.32-0.52	RM20W3K <sup>(1)</sup>	RC20W3K <sup>(1)</sup>	1.15	1.60
		20-18	0.50-0.93	RM18W3K <sup>(1)</sup>	RC18W3K <sup>(1)</sup>	1.30	2.10
	Stamped & Formed reeled contacts See note (2) for loose piece	26-24	0.13-0.25	SM24W3TK6 <sup>(2)</sup>	SC24W3TK6 <sup>(2)</sup>	-	0.90-1.60
		26-24	0.13-0.25	SM24W3S26 <sup>(2)</sup>	SC24W3S25 <sup>(2)</sup>	-	0.90-1.60
		22-20	0.32-0.52	SM20W3TK6 <sup>(2)</sup>	SC20W3TK6 <sup>(2)</sup>	-	1.20-2.10
		22-20	0.32-0.52	SM20W3S26 <sup>(2)</sup>	SC20W3S25 <sup>(2)</sup>	-	1.20-2.10
PCB	Machined <sup>(3)</sup>	-	-	RMW5016K	RCW5016K	-	-

(1): Example of plating, for other plating see page 164 (2): Loose piece contact available if putting L. Example: SM20WL3TK6 (3): For dimensions see page 168 Note: all dimensions are in mm

#20	Contact type	Plating	Cable acceptance (AWG)	Wire stripping length
Hand solder	Loaded in the connector	Min 0.4µ gold over 0.8µ Ni	22 to 18	3.8 mm

6

Electrical Characteristics	
<b>UTS 106</b> UL 6A 250V UL94 V-0	<b>UTS 10E6/10D6</b> UL 6A 250V UL94 HB
<b>CSA</b> 4A 250V UL94 V-0	<b>CSA</b> 6A 250V UL94 HB
<b>IEC</b> 7A 32V 1.5kV 3	

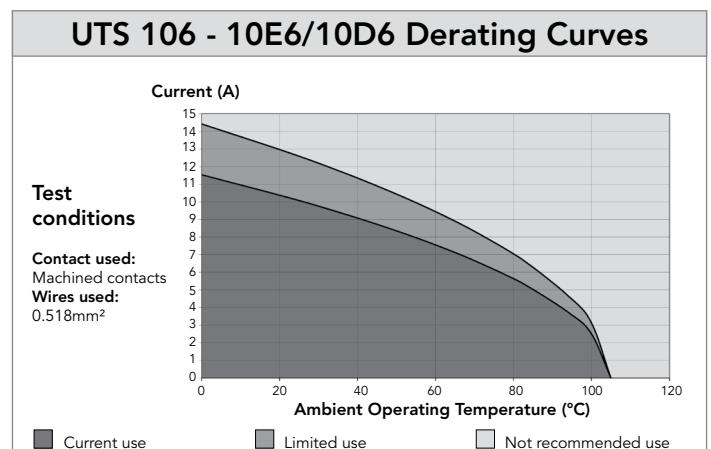

## 10E98/10D98 (Shell size 10, 6x#20)

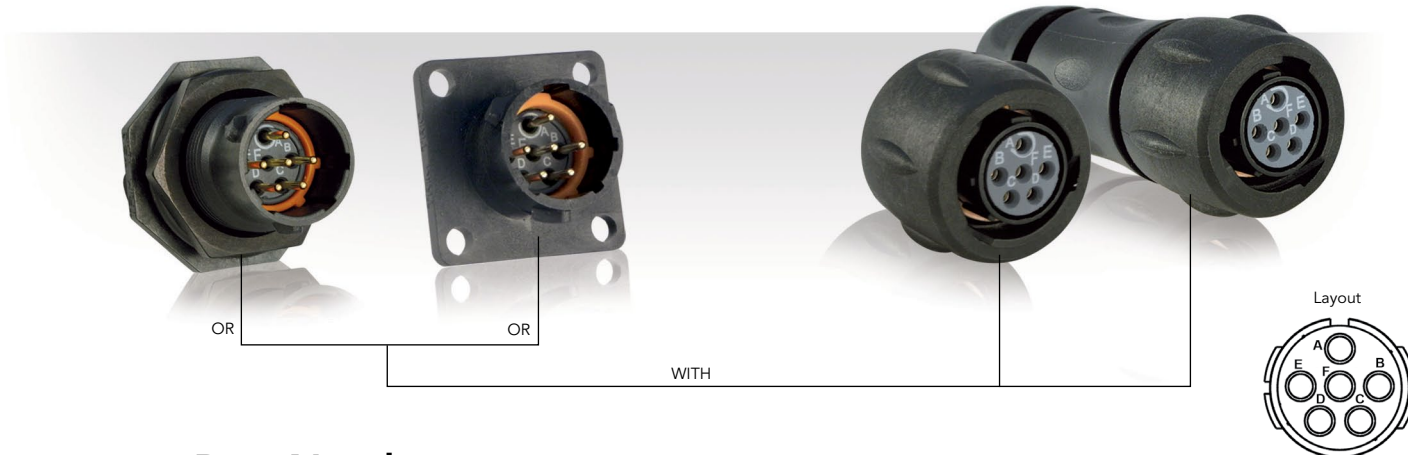

### Connector Part Numbers

Contact type	Connector type	Backshell	Part number	
			Male insert	Female insert
Hand solder electrical contacts loaded see page 91	Square flange receptacle	Without (Fig. 6)	<b>UTS010E98P</b>	<b>UTS010E98S</b>
	Plug	Without (Fig. 1)	<b>UTS610E98P</b>	<b>UTS610E98S</b>
		Cable gland (Fig. 2)	<b>UTS6JC10E98P</b>	<b>UTS6JC10E98S</b>
	Jam nut receptacle	Without (Fig. 3)	<b>UTS710E98P</b>	<b>UTS710E98S</b>
PCB contacts loaded see page 91	Square flange receptacle	Without (Fig. 7)	<b>UTS010D98P</b>	<b>UTS010D98S</b>
	Jam nut receptacle with stand off and with hold down clips	Without (Fig. 4)	<b>UTS710D98P32</b>	<b>UTS710D98S32</b>
	Jam nut receptacle with stand off and without hold down clip	Without (Fig. 5)	<b>UTS710D98P</b>	<b>UTS710D98S</b>

Possibilities of discrimination/keying methods see page 208

Sealed unmatred

### Overmoulded Cable Assembly Part Numbers

Overmoulding type	Connector type	Wire size (mm <sup>2</sup> )	Harmonized cable part number <sup>(1)</sup>	Part number (length: 1m.)*	
				Male plug	Female plug
Straight ending	Plug	0.5	H05 VV - F 6x0.5	<b>HAUTS0V10E98PST100</b>	<b>HAUTS0V10E98SST100</b>
Right angle ending	Plug	0.5	H05 VV - F 6x0.5	<b>HAUTS0V10E98PRA100</b>	<b>HAUTS0V10E98SRA100</b>

(1) Other cable available on demand

\* Other lengths available on demand



10E98/10D98 (Shell size 10, 6x#20)

Dimensions

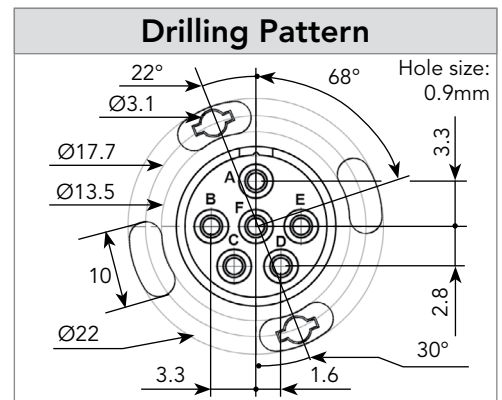
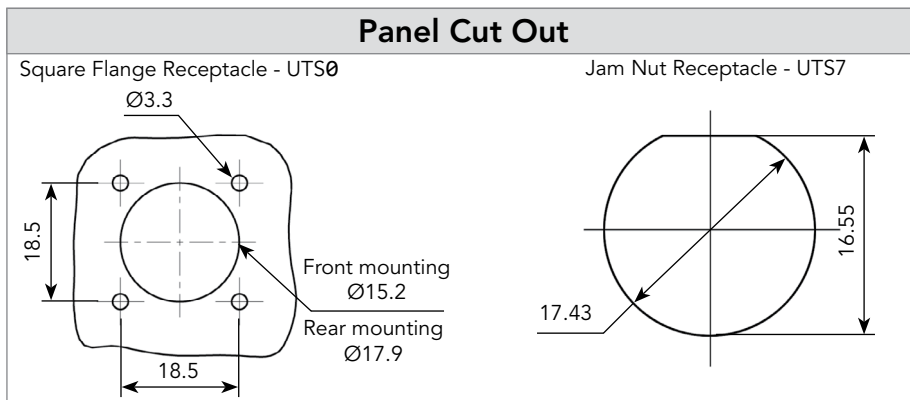
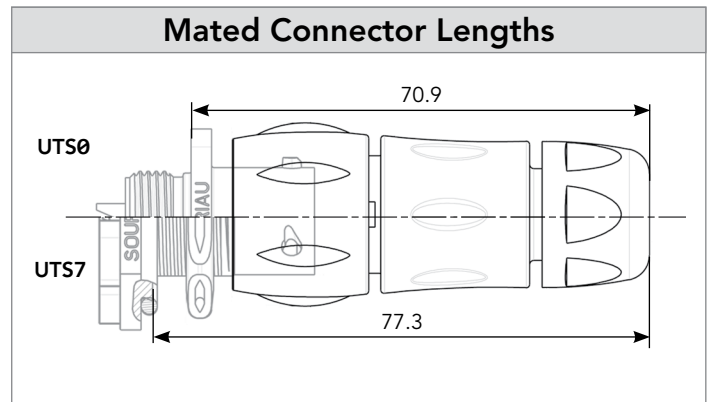
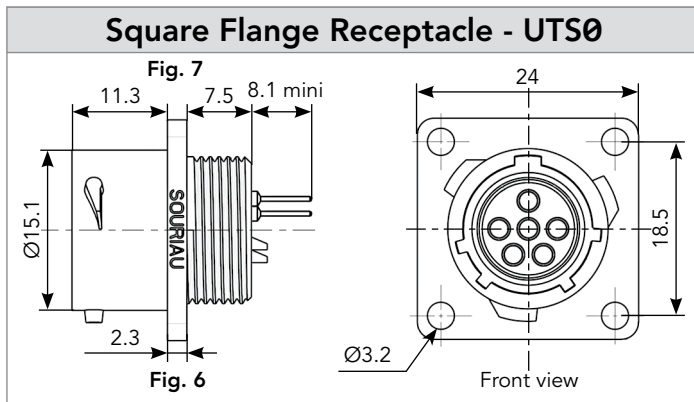
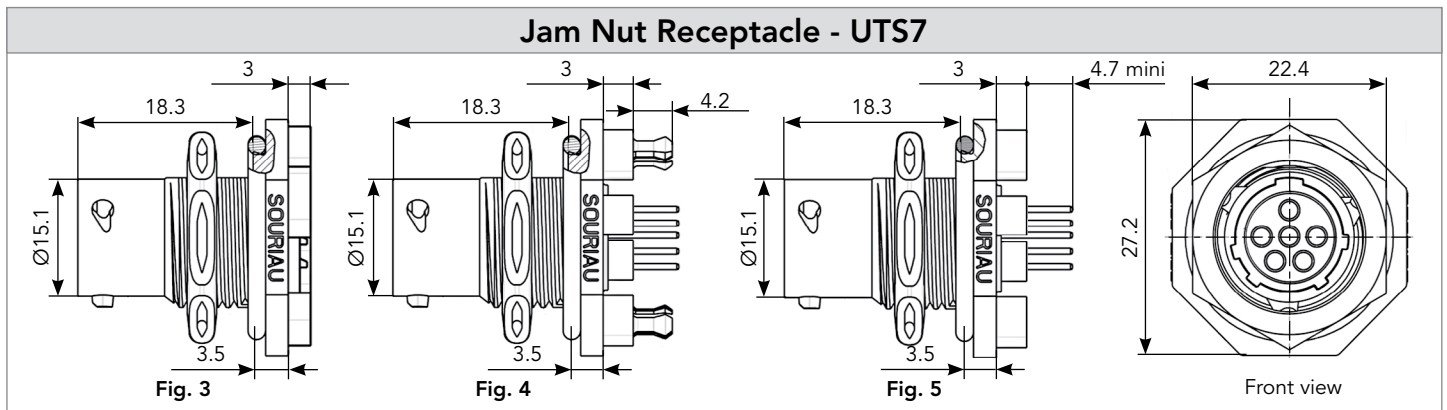
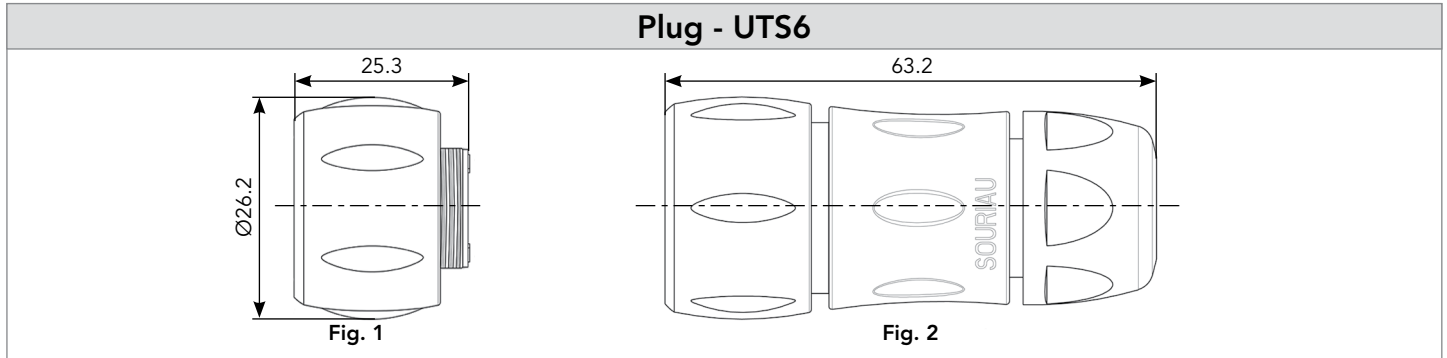

Note: Overmoulded cable assembly dimensions available page 179.

Note: all dimensions are in mm

10E98/10D98 (Shell size 10, 6x#20)

Accessories and Tooling

**Jam Nut Sealing Caps**



IP68/69K

Part number
UTS10DCG



IP68/69K Metal terminal

Part number
UTS10DCGR

**Plug Protective Cap**



IP68/69K

Part number
UTS610DCG

**Square Flange Sealing Cap**



IP68/69K Metal terminal

Part number
UTS10DCGE

**Plastic Protective Cap**



Part numbers	
Receptacle cap	Plug cap
85005586A	85005595

**Gasket**



Part numbers
UTFD12B

**Color Coding Rings**

G for Green 

Y for Yellow 

R for Red 

Part numbers	
Receptacles	Plugs
UTS710CCRR	UTS610CCRR
UTS710CCRY	UTS610CCRY
UTS710CCRG	UTS610CCRG

10E98/10D98 (Shell size 10, 6x#20)

Contacts

#20	Contact type	Plating	Cable acceptance (AWG)	Wire stripping length
Hand solder	Loaded in the connector	Min 0.4μ gold over 0.8μ Ni	22 to 18	5 mm
PCB	Machined <sup>(1)</sup>	Min 0.4μ gold over 0.8μ Ni	-	-

(1): For dimensions see page 169

**Electrical Characteristics**

**UL**  
6A 250V UL94 HB

**CSA**  
6A 250V UL94 HB

**IEC**  
7A 50V 1.5kV 3

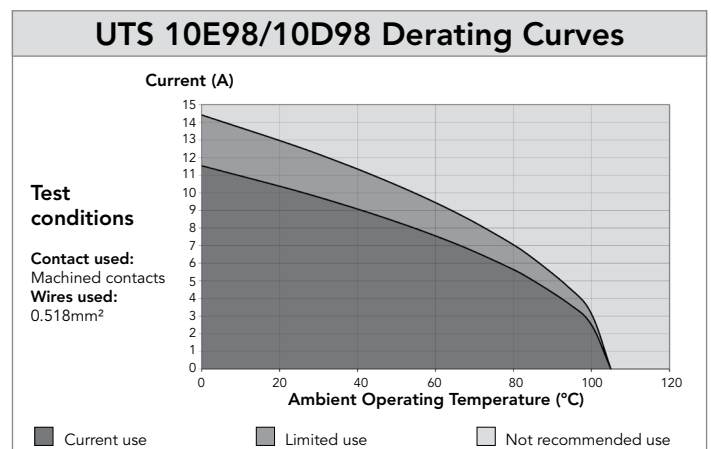

### 147 - 14E7/14D7 (Shell size 14, 6 + ground, 7x#16)



### Connector Part Numbers

Contact type	Connector type	Backshell	Part number	
			Male insert	Female insert
Crimp contacts supplied separately see page 95	Square flange receptacle	Without (Fig. 2)	<b>UTS0147P</b>	<b>UTS0147S</b>
	Free hanging receptacle	Cable gland and grommet (Fig. 3)	<b>UTS1GJC147P</b>	-
	Free hanging receptacle	Nut and grommet (Fig. 4)	<b>UTS1GN147P</b>	-
	Free hanging receptacle	Cable gland (Fig. 3)	<b>UTS1JC147P</b>	<b>UTS1JC147S</b>
	Plug	Without (Fig. 5)	<b>UTS6147P</b>	<b>UTS6147S</b>
	Plug	Cable gland and grommet (Fig. 6)	-	<b>UTS6GJC147S</b>
	Plug	Nut and grommet (Fig. 7)	-	<b>UTS6GN147S</b>
	Plug	Cable gland (Fig. 6)	<b>UTS6JC147P</b>	<b>UTS6JC147S</b>
	Jam nut receptacle	Without (Fig. 8)	<b>UTS7147P</b>	<b>UTS7147S</b>
	Jam nut receptacle	Cable gland and grommet (Fig. 10)	<b>UTS7GJC147P</b>	-
Jam nut receptacle	Nut and grommet (Fig. 9)	<b>UTS7GN147P</b>	-	
PCB contacts loaded see page 95	Jam nut receptacle	With stand off and hold down clip (Fig. 11)	<b>UTS7147PSEK9</b>	-
Screw contacts loaded	Jam nut receptacle	Without (Fig. 8)	<b>UTS7147PSCR</b>	<b>UTS7147SSCR</b>
	Free hanging receptacle	Cable gland (Fig. 3)	<b>UTS1JC147PSCR</b>	-
	Plug	Cable gland (Fig. 6)	<b>UTS6JC147PSCR</b>	<b>UTS6JC147SSCR</b>
Hand solder electrical contacts loaded see page 95	Square flange receptacle	Without (Fig. 2)	<b>UTS014E7P</b>	<b>UTS014E7S</b>
	Plug	Cable gland (Fig. 6)	<b>UTS6JC14E7P</b>	<b>UTS6JC14E7S</b>
	Jam nut receptacle	Without (Fig. 8)	<b>UTS714E7P</b>	<b>UTS714E7S</b>
PCB contacts loaded see page 95	Square flange receptacle	Without (Fig. 1)	<b>UTS014D7P</b>	<b>UTS014D7S</b>
	Jam nut receptacle with stand off and hold down clips	Without (Fig. 11)	<b>UTS714D7P32</b>	<b>UTS714D7S32</b>
	Jam nut receptacle with stand off and without hold down clip	Without (Fig. 11)	<b>UTS714D7P</b>	<b>UTS714D7S</b>

Sealed unmatd

### Overmoulded Cable Assembly Part Numbers

Overmoulding type	Connector type	Wire size (mm <sup>2</sup> )	Harmonized cable part number <sup>(1)</sup>	Part number (length: 1m.)*	
				Male plug	Female plug
Straight ending	Plug	1.5	H05 VV - F 7x1.5	<b>HAUTS0V147PST100</b>	<b>HAUTS0V147SST100</b>
				<b>HAUTS0V14E7PST100</b>	<b>HAUTS0V14E7SST100</b>
Right angle ending	Plug	1.5	H05 VV - F 7x1.5	<b>HAUTS0V147PRA100</b>	<b>HAUTS0V147SRA100</b>
				<b>HAUTS0V14E7PRA100</b>	<b>HAUTS0V14E7SRA100</b>

(1) Other cable available on demand

\* Other lengths available on demand

147 - 14E7/14D7 (Shell size 14, 6 + ground, 7x#16)

Dimensions

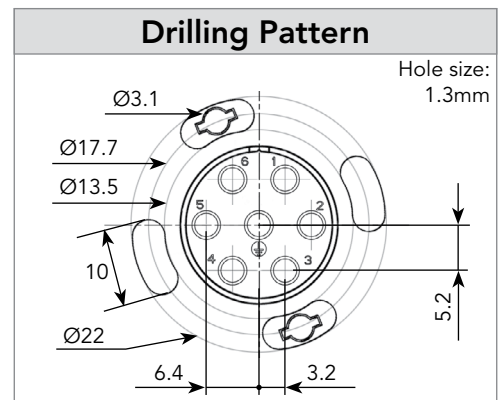
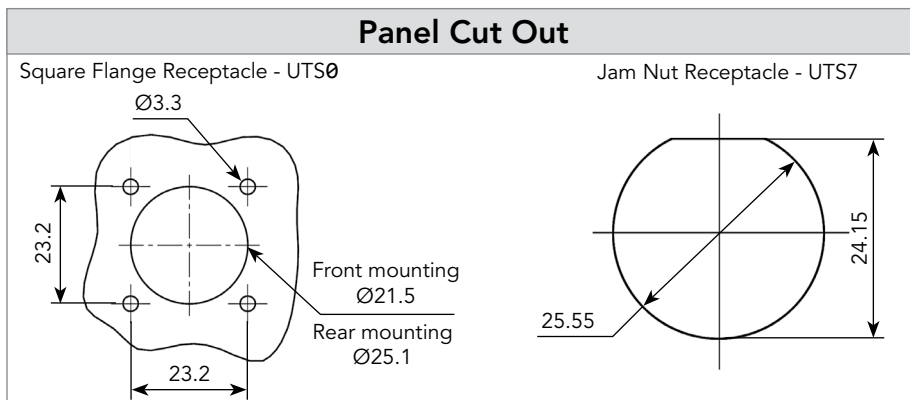
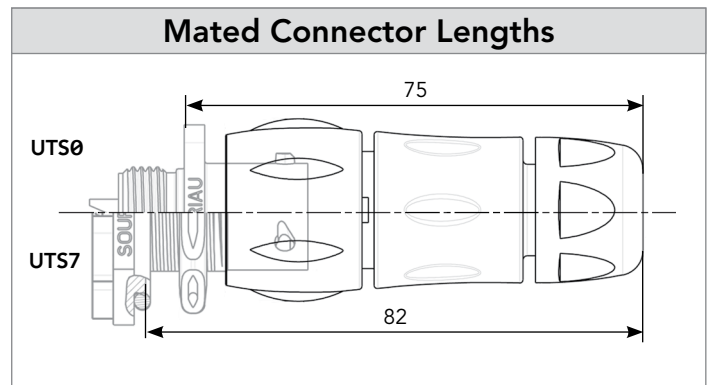
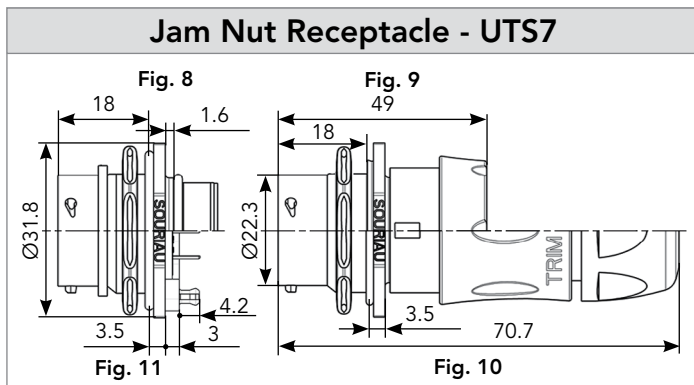
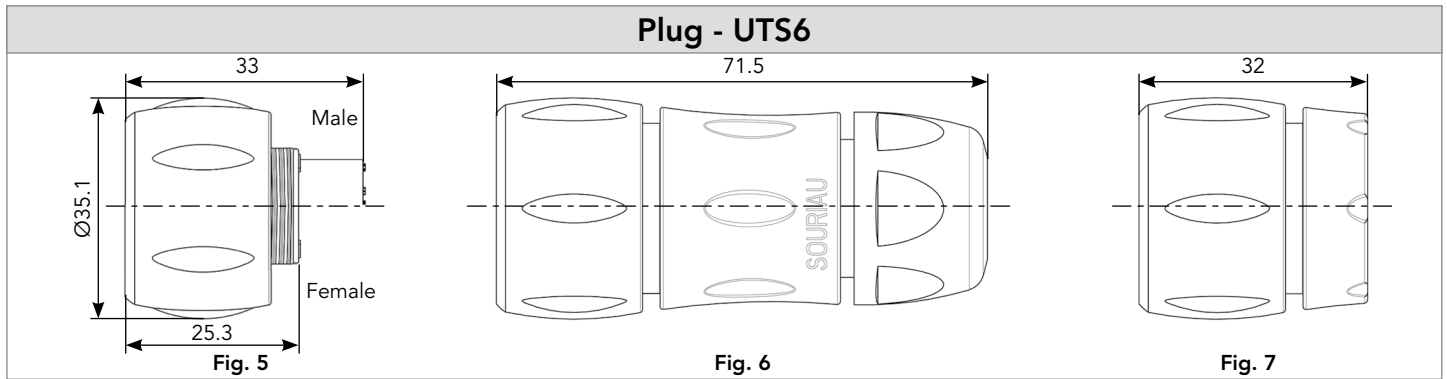
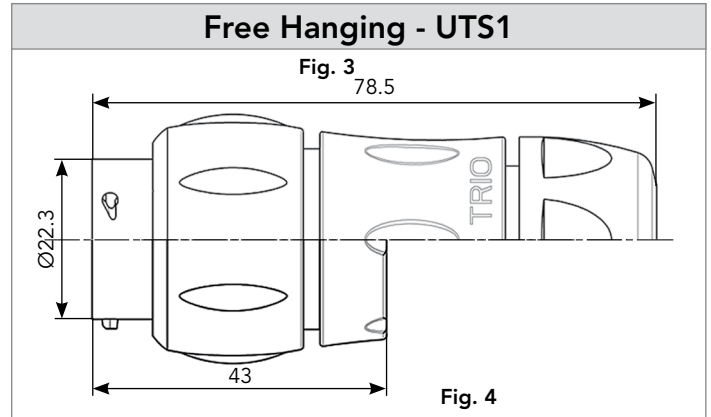
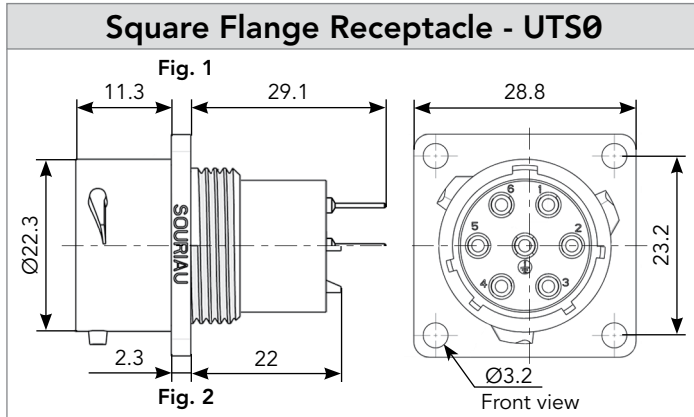

Note: Overmoulded cable assembly dimensions available page 179.

Note: all dimensions are in mm

# 147 - 14E7/14D7 (Shell size 14, 6 + ground, 7x#16)

## Accessories and Tooling

### Jam Nut Sealing Caps



IP68/69K

Part number
UTS14DCG



IP68/69K Metal terminal

Part number
UTS14DCGR

### Handle (without Head)



Part number
SHANDLES

### Tool Kit



Part number
TOOLKIT

### Plug Sealing Cap



IP68/69K

Part number
UTS614DCG

### Square Flange Sealing Cap



IP68/69K Metal terminal

Part number
UTS14DCGE

### Crimp Tooling (without Shandles)



Contacts	Contact size	Part number of head	
RM/RC 28M1K <sup>(1)</sup>	Standard contacts #16 Ø 1.6mm	S16RCM20*	
RM/RC 24M9K <sup>(1)</sup>		S16RCM20*	
RM/RC 20M13K <sup>(1)</sup>		S16RCM20*	
RM/RC 20M12K <sup>(1)</sup>		S16RCM20*	
RM/RC 16M23K <sup>(1)</sup>		S16RCM16*	
RM/RC 14M30K <sup>(1)</sup>		S16RCM14*	
SM/SC 24ML1TK6 <sup>(1)</sup>		S16SCM20*	
SM/SC 20ML1TK6 <sup>(1)</sup>		S16SCM20*	
SM/SC 16ML1TK6 <sup>(1)</sup>		S16SCML1*	
SM/SC 14ML1TK6 <sup>(1)</sup>		S16SCML1*	
SM/SC 16ML11TK6 <sup>(1)</sup>		S16SCML11*	
RMDXK10D28K		Coaxial contacts	M10S1J with die set & stop bushing see page 200 to 204
RCDXK1D28K			
RM/RC DX60xxD28K			
RM/RC DXK10D28 + yorK090			
RM/RC DX60xxD28			

(1): Example of plating, for other plating options see page 164  
\* Heads to be used with handle PN: SHANDLES

### Plastic Protective Cap



Part numbers	
Receptacle cap	Plug cap
85005588A	85005597

### Gasket



Part numbers
UTFD14B

### Color Coding Rings

G for Green 

Y for Yellow 

R for Red 

Part numbers	
Receptacles	Plugs
UTS714CCRR	UTS614CCRR
UTS714CCRY	UTS614CCRY
UTS714CCRG	UTS614CCRG

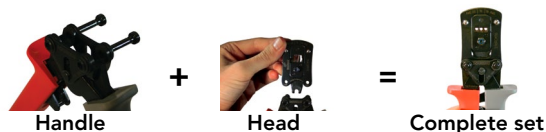

# 147 - 14E7/14D7 (Shell size 14, 6 + ground, 7x#16)

## Contacts

#16	Contact type	AWG	Part number		Max wire Ø	Max insulator Ø
			Male	Female		
Crimp	Machined	30-28	RM28M1K <sup>(1)</sup>	RC28M1K <sup>(1)</sup>	0.55	1.00
		26-24	RM24M9K <sup>(1)</sup>	RC24M9K <sup>(1)</sup>	0.80	1.60
		22-20	RM20M13K <sup>(1)</sup>	RC20M13K <sup>(1)</sup>	1.15	1.80
		22-20	RM20M12K <sup>(1)</sup>	RC20M12K <sup>(1)</sup>	1.15	2.20
		20-16	RM16M23K <sup>(1)</sup>	RC16M23K <sup>(1)</sup>	1.80	3.20
		16-14	RM14M30K <sup>(1)</sup>	RC14M30K <sup>(1)</sup>	2.30	3.20
	Stamped & Formed reeled contacts <small>See note (2) for loose piece</small>	26-24	SM24M1TK6 <sup>(1)(2)</sup>	SC24M1TK6 <sup>(1)(2)</sup>	-	0.90-1.60
		22-20	SM20M1TK6 <sup>(1)(2)</sup>	SC20M1TK6 <sup>(1)(2)</sup>	-	1.20-2.10
		18-16	SM16M1TK6 <sup>(1)(2)</sup>	SC16M1TK6 <sup>(1)(2)</sup>	-	3.20
		18-16	SM16M11TK6 <sup>(1)(2)</sup>	SC16M11TK6 <sup>(1)(2)</sup>	-	3.00
14		SM14M1TK6 <sup>(1)(2)</sup>	SC14M1TK6 <sup>(1)(2)</sup>	-	3.20	
PCB	Machined <sup>(3)</sup>	-	RM20M12E83K <sup>(1)</sup>	RC20M12E84K <sup>(1)</sup>	-	-
Coaxial	Cable Multipiece	see pages 167, 200 to 206	RMDXK10D28	RCDXK1D28	-	-
	Cable Monocrimp		RMDX60xxD28	RCDX60xxD28	-	-
	Twisted pair Multipiece		RMDXK10D28 + york090	RCDXK1D28 + york090	-	-
	Twisted pair Monocrimp		RMDX60xxD28	RCDX60xxD28	-	-
Fiber optic	POF contacts (Plastic Optical Fiber)	-	RMPOF1000	RCPOF1000B	-	-
Hand-solder	Loaded in the connector	14-18	-	-	-	-



(1): Example of plating, for other plating see page 164    (2): Loose piece contact available if putting L. Example: SM20ML1TK6    (3): For dimensions see page 168    Note: all dimensions are in mm

### Electrical Characteristics

**UL**  
10A 500V UL94 V-0

**CSA**  
7A 500V UL94 V-0

**IEC**  
16A 300V 4kV 3  
Temperature elevation: 50°C

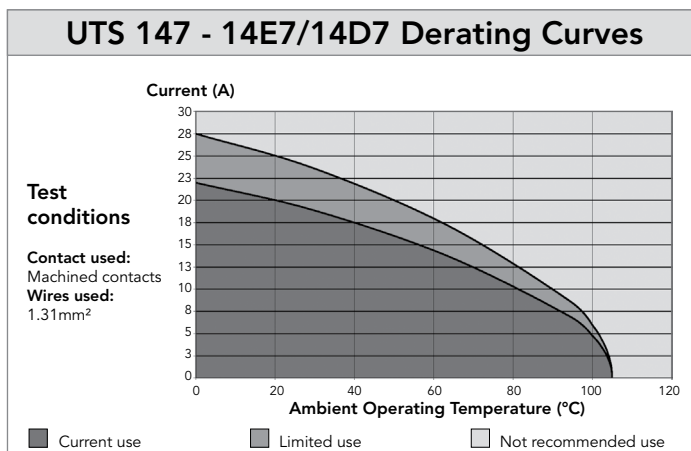

### 10E7/10D7 (Shell size 10, 7x#20)

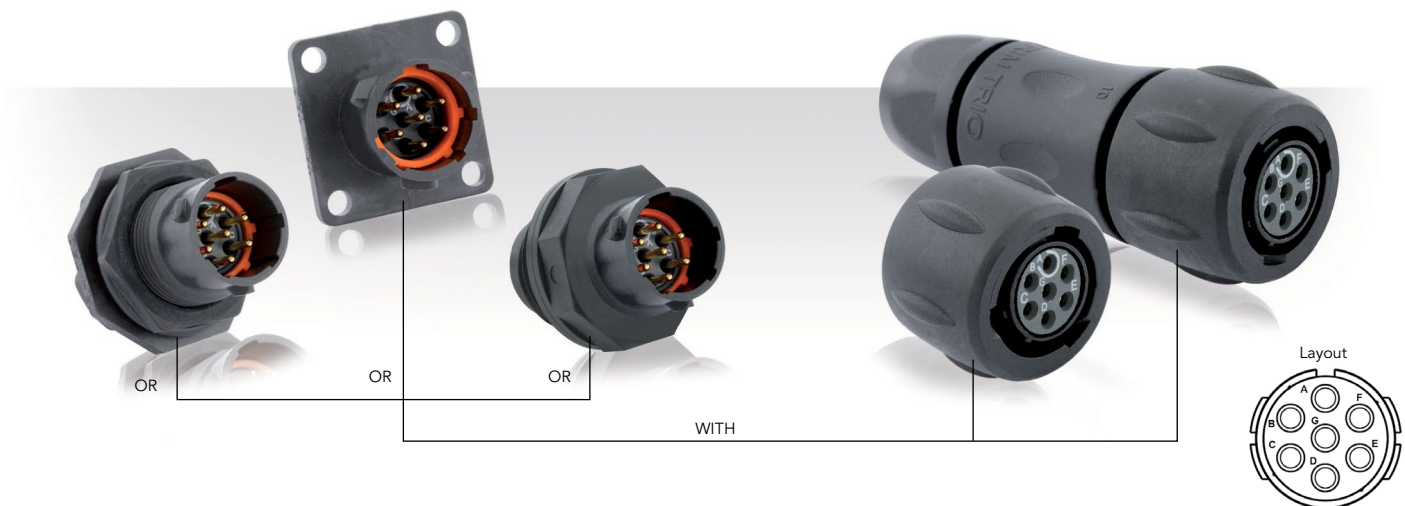

### Connector Part Numbers

Contact type	Connector type	Backshell	Part number	
			Male insert	Female insert
Hand solder electrical contacts loaded see page 99	Square flange receptacle	Without (Fig. 1)	<b>UTS010E7P</b>	<b>UTS010E7S</b>
	Plug	Without (Fig. 2)	<b>UTS610E7P</b>	<b>UTS610E7S</b>
		Cable gland (Fig. 3)	<b>UTS6JC10E7P</b>	<b>UTS6JC10E7S</b>
	Jam nut receptacle	Without (Fig. 4)	<b>UTS710E7P</b>	<b>UTS710E7S</b>
	M16 threaded receptacle	Without (Fig. 5)	<b>UTS710E7PM16</b>	<b>UTS710E7SM16</b>

Possibilities of discrimination/keying methods see page 208

Sealed unmated

### Overmoulded Cable Assembly Part Numbers

Overmoulding type	Connector type	Wire size (mm <sup>2</sup> )	Harmonized cable part number <sup>(1)</sup>	Part number (length: 1m.)*	
				Male plug	Female plug
Straight ending	Plug	0.5	H05 VV - F 7x0.5	<b>HAUTS0V10E7PST100</b>	<b>HAUTS0V10E7SST100</b>
Right angle ending	Plug	0.5	H05 VV - F 7x0.5	<b>HAUTS0V10E7PRA100</b>	<b>HAUTS0V10E7SRA100</b>

(1) Other cable available on demand

\* Other lengths available on demand



10E7/10D7 (Shell size 10, 7x#20)

Dimensions

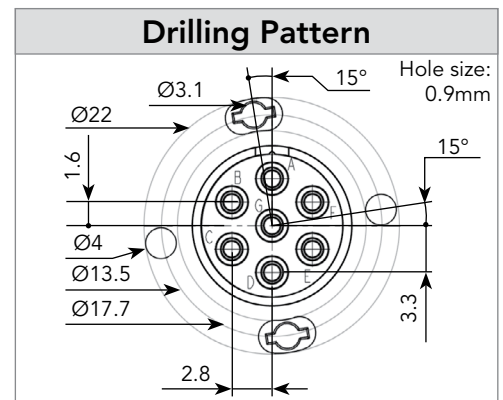
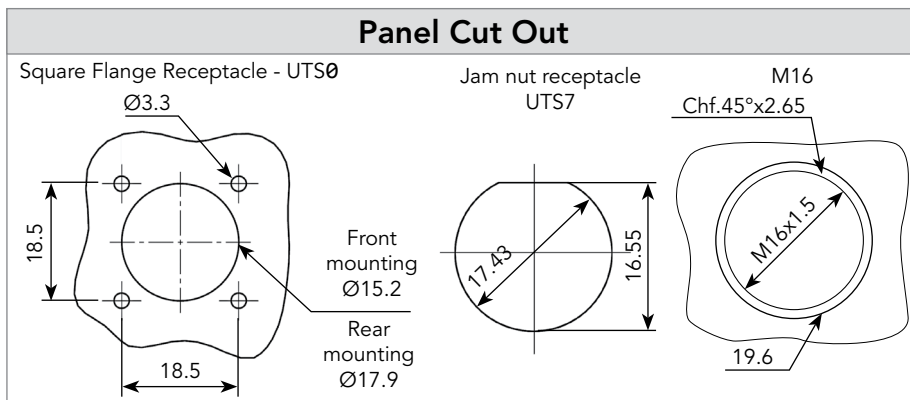
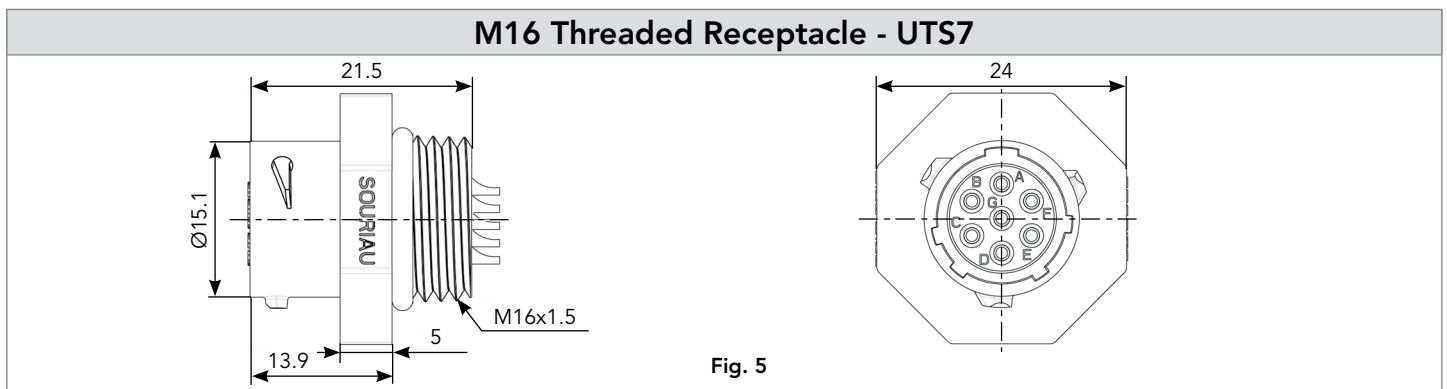
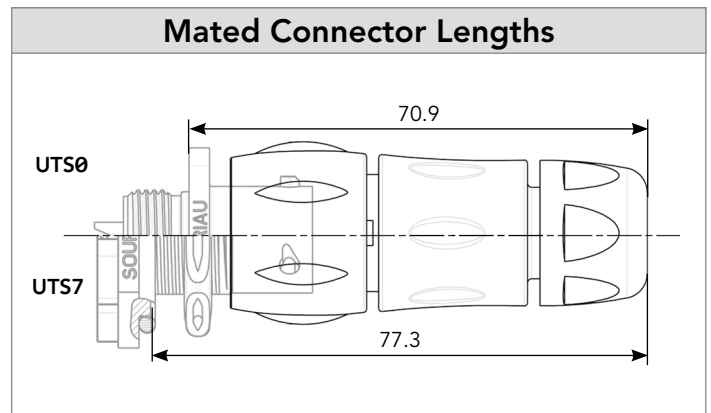
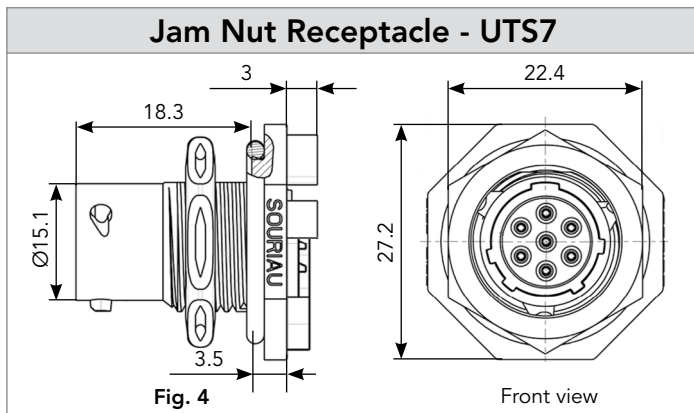
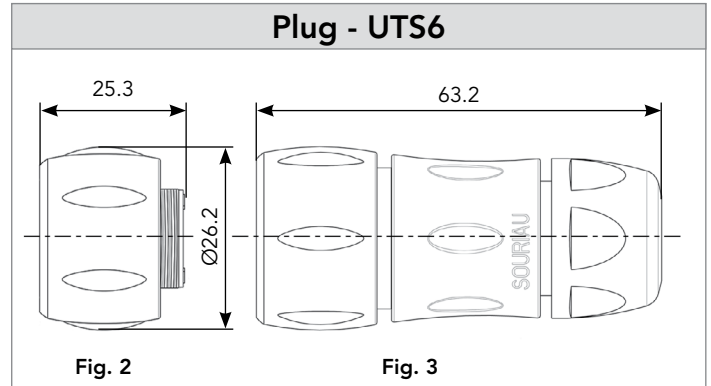
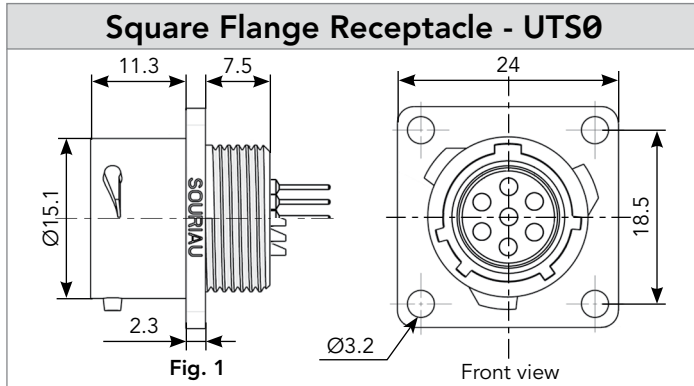

Note: Overmoulded cable assembly dimensions available page 179.

Note: all dimensions are in mm

10E7/10D7 (Shell size 10, 7x#20)

Accessories and Tooling

**Jam Nut Sealing Caps**



IP68/69K

Part number
UTS10DCG



IP68/69K Metal terminal

Part number
UTS10DCGR

**Plug Sealing Cap**



IP68/69K

Part number
UTS610DCG

**Square Flange Sealing Cap**



IP68/69K Metal terminal

Part number
UTS10DCGE

**Plastic Protective Cap**



Part numbers	
Receptacle cap	Plug cap
85005586A	85005595

**Gasket**



Part numbers
UTFD12B

**Color Coding Rings**

G for Green 

Y for Yellow 

R for Red 

Part numbers	
Receptacles	Plugs
UTS710CCRR	UTS610CCRR
UTS710CCRY	UTS610CCRY
UTS710CCRG	UTS610CCRG

**10E7/10D7** (Shell size 10, 7x#20)

**Contacts**

#20	Contact type	Plating	Cable acceptance (AWG)	Wire stripping length
Handsold	Loaded in the connector	Min 0.4μ gold over 0.8μ Ni	22 to 18	3.8 mm

**Electrical Characteristics**

**UL**  
6A 250V UL94 HB

**CSA**  
6A 250V UL94 HB

**IEC**  
7A 50V 1.5kV 3

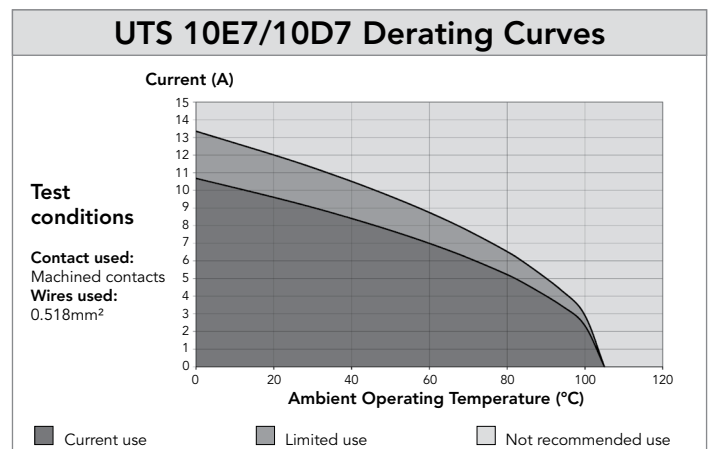

**128** (Shell size 12, 8x#16)



**Connector Part Numbers**

Contact type	Connector type	Backshell	Part number	
			Male insert	Female insert
Crimp contacts supplied separately see page 103	Square flange receptacle	Without (Fig. 1)	<b>UTS0128P</b>	<b>UTS0128S</b>
	Free hanging receptacle	Cable gland and grommet (Fig. 2)	<b>UTS1GJC128P</b>	-
	Free hanging receptacle	Nut and grommet (Fig. 3)	<b>UTS1GN128P</b>	-
	M20 threaded receptacle	Panel gasket and nut (Fig. 8)	<b>UTS7128PM20NUT</b>	<b>UTS7128SM20NUT</b>
		Panel gasket (Fig. 9)	<b>UTS7128PM20</b>	<b>UTS7128SM20</b>
	Free hanging receptacle	Cable gland (Fig. 2)	<b>UTS1JC128P</b>	<b>UTS1JC128S</b>
	Plug	Without (Fig. 10)	<b>UTS6128P</b>	<b>UTS6128S</b>
	Plug	Cable gland and grommet (Fig. 11)	-	<b>UTS6GJC128S</b>
	Plug	Nut and grommet (Fig. 12)	-	<b>UTS6GN128S</b>
	Plug	Cable gland (Fig. 11)	<b>UTS6JC128P</b>	<b>UTS6JC128S</b>
	Jam nut receptacle	Without (Fig. 4)	<b>UTS7128P</b>	<b>UTS7128S</b>
	Jam nut receptacle	Cable gland and grommet (Fig. 7)	<b>UTS7GJC128P</b>	-
Jam nut receptacle	Nut and grommet (Fig. 6)	<b>UTS7GN128P</b>	-	
PCB contacts loaded see page 103	Jam nut receptacle	With stand off and hold down clip (Fig. 5)	<b>UTS7128PSEK9</b>	-

Possibilities of discrimination/keying methods see page 208

**Overmoulded Cable Assembly Part Numbers**

Overmoulding type	Connector type	Wire size (mm <sup>2</sup> )	Harmonized cable part number <sup>(1)</sup>	Part number (length: 1m.)*	
				Male plug	Female plug
Straight ending	Plug	1.5	H05 VV - F 8x1.5	<b>HAUTS0V128PST100</b>	<b>HAUTS0V128SST100</b>
Right angle ending	Plug	1.5	H05 VV - F 8x1.5	<b>HAUTS0V128PRA100</b>	<b>HAUTS0V128SRA100</b>

(1) Other cable available on demand

\* Other lengths available on demand

128 (Shell size 12, 8x#16)

Dimensions

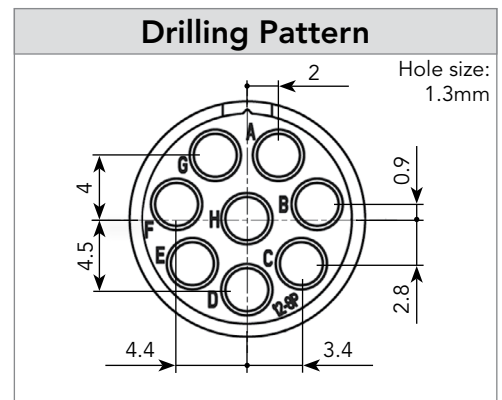
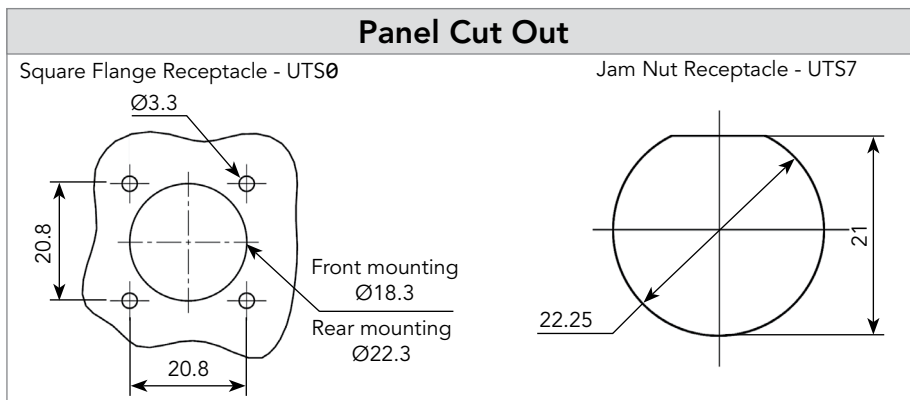
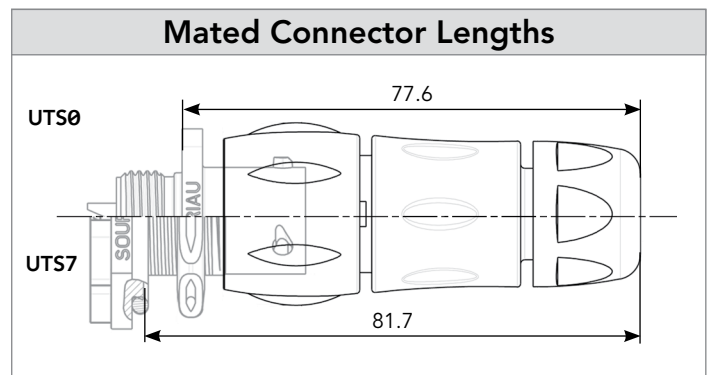
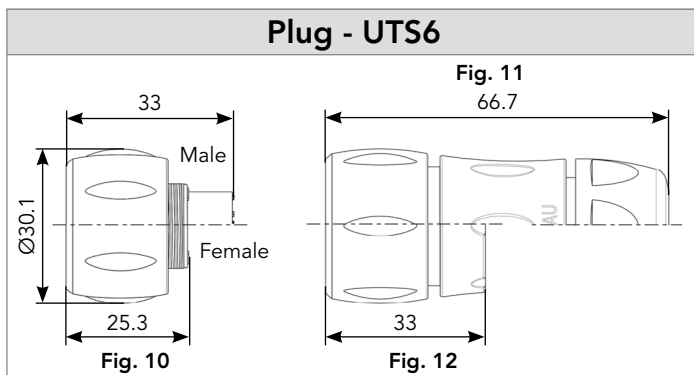
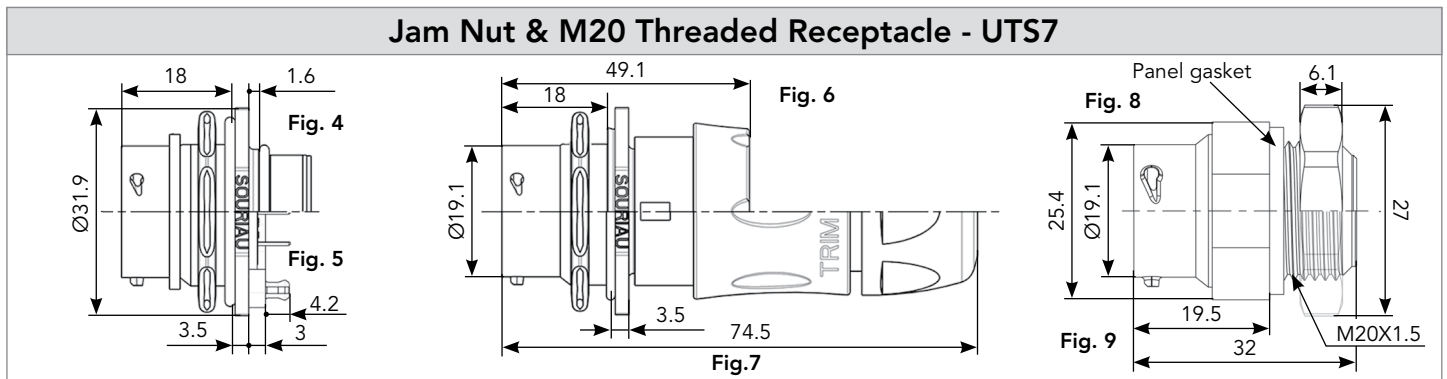
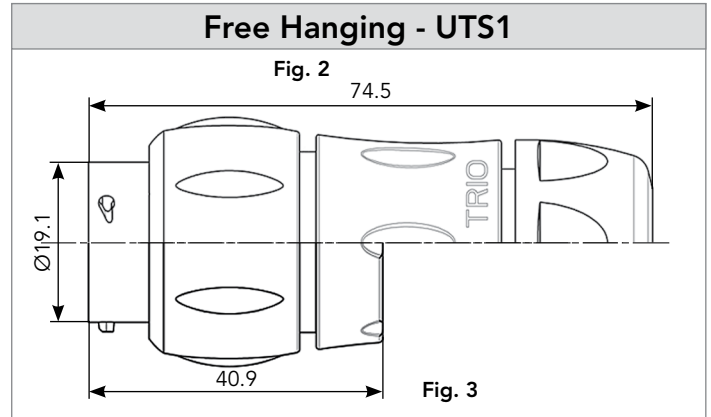
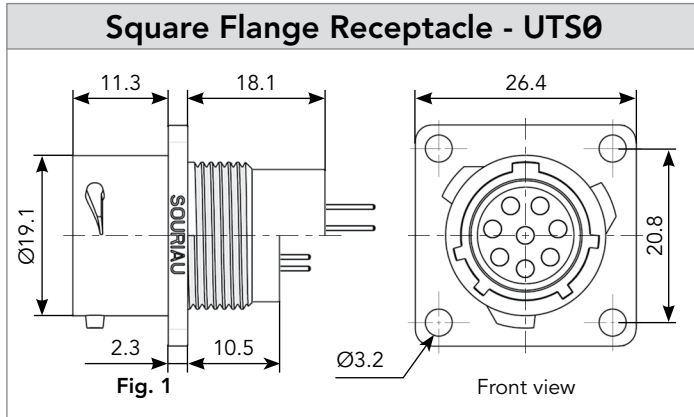

Note: Overmoulded cable assembly dimensions available page 179.

Note: all dimensions are in mm

128 (Shell size 12, 8x#16)

## Accessories and Tooling

### Jam Nut Sealing Caps



IP68/69K

Part number
UTS12DCG



IP68/69K Metal terminal

Part number
UTS12DCGR

### Handle (without Head)



Part number
SHANDLES

### Tool Kit



Part number
TOOLKIT

### Plug Sealing Cap



IP68/69K

Part number
UTS612DCG

### Square Flange Sealing Cap



IP68/69K Metal terminal

Part number
UTS12DCGE

### Crimp Tooling (without Shandles)



Contacts	Contact size	Part number of head	
RM/RC 28M1K <sup>(1)</sup>	Standard contacts #16 Ø 1.6mm	S16RCM20*	
RM/RC 24M9K <sup>(1)</sup>		S16RCM20*	
RM/RC 20M13K <sup>(1)</sup>		S16RCM20*	
RM/RC 20M12K <sup>(1)</sup>		S16RCM20*	
RM/RC 16M23K <sup>(1)</sup>		S16RCM16*	
RM/RC 14M30K <sup>(1)</sup>		S16RCM14*	
SM/SC 24ML1TK6 <sup>(1)</sup>		S16SCM20*	
SM/SC 20ML1TK6 <sup>(1)</sup>		S16SCM20*	
SM/SC 16ML1TK6 <sup>(1)</sup>		S16SCML1*	
SM/SC 14ML1TK6 <sup>(1)</sup>		S16SCML1*	
SM/SC 16ML11TK6 <sup>(1)</sup>		S16SCML11*	
RMDXK10D28K		Coaxial contacts	M10S1J with die set & stop bushing see page 200 to 204
RCDXK1D28K			
RM/RC DX60xxD28K			
RM/RC DXK10D28 + york090			
RM/RC DX60xxD28			

<sup>(1)</sup>: Example of plating, for other plating options see page 164  
\* Heads to be used with handle PN: SHANDLES

### Plastic Protective Cap



Part numbers	
Receptacle cap	Plug cap
85005587A	85005596

### Gasket



Part numbers
UTFD13B

### Color Coding Rings

G for Green 

Y for Yellow 

R for Red 

Part numbers	
Receptacles	Plugs
UTS712CCRR	UTS612CCRR
UTS712CCRY	UTS612CCRY
UTS712CCRG	UTS612CCRG

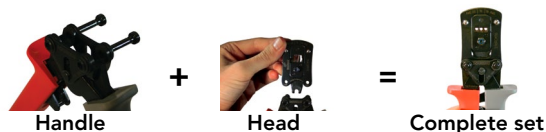

# 128 (Shell size 12, 8x#16)

## Contacts

#16	Contact type	AWG	Part number		Max wire Ø	Max insulator Ø
			Male	Female		
Crimp	Machined	30-28	RM28M1K <sup>(1)</sup>	RC28M1K <sup>(1)</sup>	0.55	1.00
		26-24	RM24M9K <sup>(1)</sup>	RC24M9K <sup>(1)</sup>	0.80	1.60
		22-20	RM20M13K <sup>(1)</sup>	RC20M13K <sup>(1)</sup>	1.15	1.80
		22-20	RM20M12K <sup>(1)</sup>	RC20M12K <sup>(1)</sup>	1.15	2.20
		20-16	RM16M23K <sup>(1)</sup>	RC16M23K <sup>(1)</sup>	1.80	3.20
		16-14	RM14M30K <sup>(1)</sup>	RC14M30K <sup>(1)</sup>	2.30	3.20
	Stamped & Formed reeled contacts See note (2) for loose piece	26-24	SM24M1TK6 <sup>(1)(2)</sup>	SC24M1TK6 <sup>(1)(2)</sup>	-	0.90-1.60
		22-20	SM20M1TK6 <sup>(1)(2)</sup>	SC20M1TK6 <sup>(1)(2)</sup>	-	1.20-2.10
		18-16	SM16M1TK6 <sup>(1)(2)</sup>	SC16M1TK6 <sup>(1)(2)</sup>	-	3.20
		18-16	SM16M11TK6 <sup>(1)(2)</sup>	SC16M11TK6 <sup>(1)(2)</sup>	-	3.00
14		SM14M1TK6 <sup>(1)(2)</sup>	SC14M1TK6 <sup>(1)(2)</sup>	-	3.20	
PCB	Machined <sup>(3)</sup>	-	RM20M12E83K <sup>(1)</sup>	RC20M12E84K <sup>(1)</sup>	-	-
Coaxial	Cable Multipiece	see pages 167, 200 to 206	RMDXK10D28	RCDXK1D28	-	-
	Cable Monocrimp		RMDX60xxD28	RCDX60xxD28	-	-
	Twisted pair Multipiece		RMDXK10D28 + york090	RCDXK1D28 + york090	-	-
	Twisted pair Monocrimp		RMDX60xxD28	RCDX60xxD28	-	-
Fiber optic	POF contacts (Plastic Optical Fiber)	-	RMPOF1000	RCPOF1000B	-	-
Hand-solder	Loaded in the connector	14-18	-	-	-	-

(1): Example of plating, for other plating see page 164 (2): Loose piece contact available if putting L. Example: SM20M1TK6 (3): For dimensions see page 168 Note: all dimensions are in mm

8

Electrical Characteristics
<p><b>UL</b> 10A 500V UL94 V-0</p> <p><b>CSA</b> 7A 500V UL94 V-0</p> <p><b>IEC</b> 10A 80V 1.5kV 3</p>

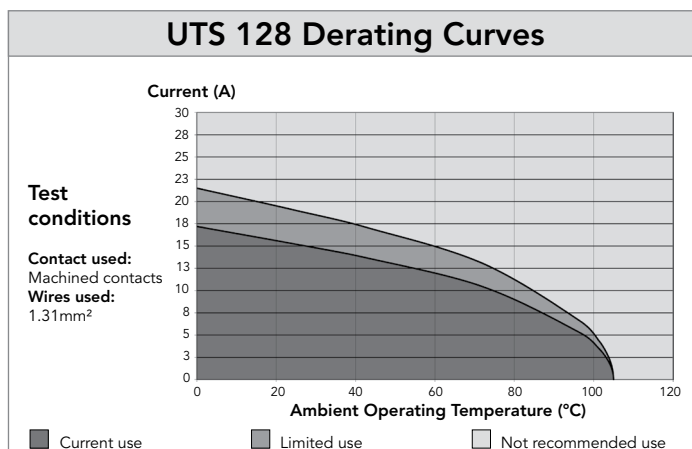

## 12E8/12D8 (Shell size 12, 8x#20)

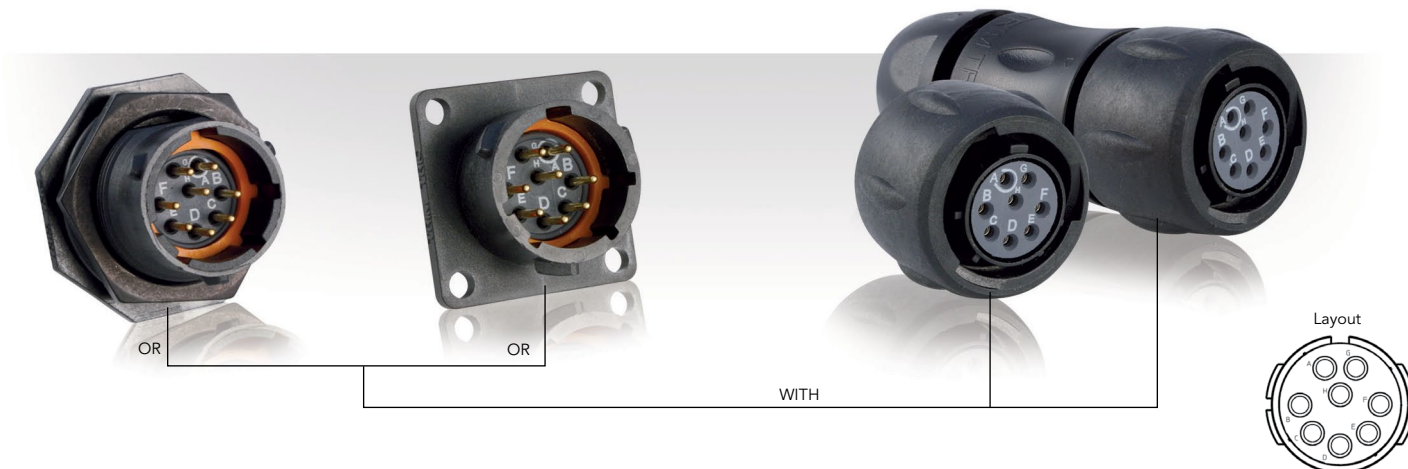

### Connector Part Numbers

Contact type	Connector type	Backshell	Part number	
			Male insert	Female insert
Hand solder electrical contacts loaded see page 107	Square flange receptacle	Without (Fig. 6)	<b>UTS012E8P</b>	<b>UTS012E8S</b>
	Plug	Without (Fig. 1)	<b>UTS612E8P</b>	<b>UTS612E8S</b>
		Cable gland (Fig. 2)	<b>UTS6JC12E8P</b>	<b>UTS6JC12E8S</b>
	Jam nut receptacle	Without (Fig. 3)	<b>UTS712E8P</b>	<b>UTS712E8S</b>
PCB contacts loaded see page 107	Square flange receptacle	Without (Fig. 7)	<b>UTS012D8P</b>	<b>UTS012D8S</b>
	Jam nut receptacle with stand off and with hold down clips	Without (Fig. 4)	<b>UTS712D8P32</b>	<b>UTS712D8S32</b>
	Jam nut receptacle with stand off and without hold down clip	Without (Fig. 5)	<b>UTS712D8P</b>	<b>UTS712D8S</b>

Possibilities of discrimination/keying methods see page 208

Sealed unmounted

### Overmoulded Cable Assembly Part Numbers

Overmoulding type	Connector type	Wire size (mm <sup>2</sup> )	Harmonized cable part number <sup>(1)</sup>	Part number (length: 1m.)*	
				Male plug	Female plug
Straight ending	Plug	0.5	H05 VV - F 8x0.5	<b>HAUTS0V12E8PST100</b>	<b>HAUTS0V12E8SST100</b>
Right angle ending	Plug	0.5	H05 VV - F 8x0.5	<b>HAUTS0V12E8PRA100</b>	<b>HAUTS0V12E8SRA100</b>

(1) Other cable available on demand

\* Other lengths available on demand



12E8/12D8 (Shell size 12, 8x#20)

Dimensions

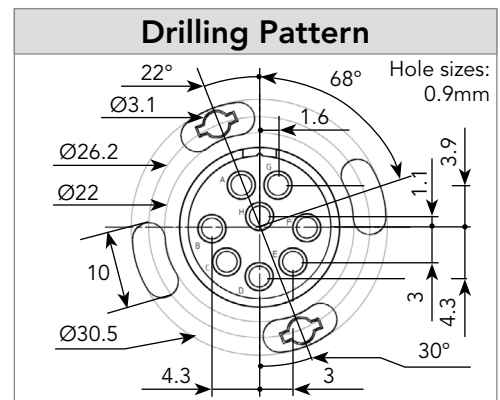
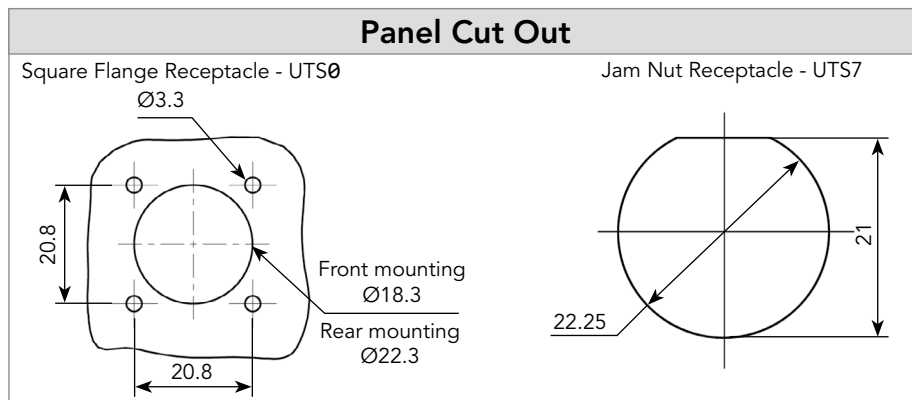
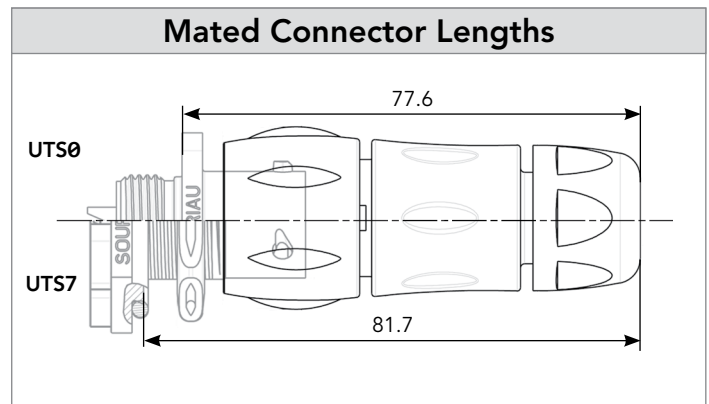
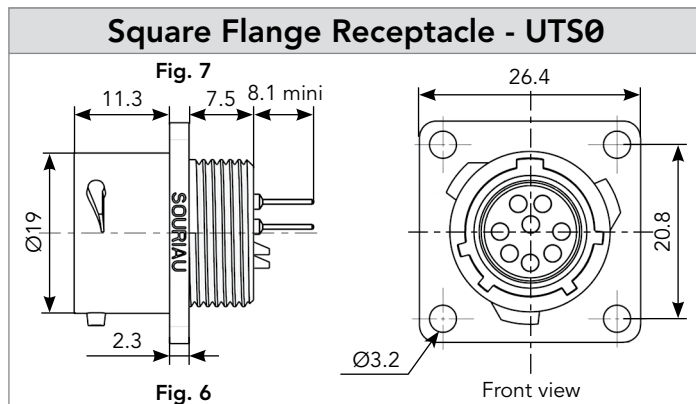
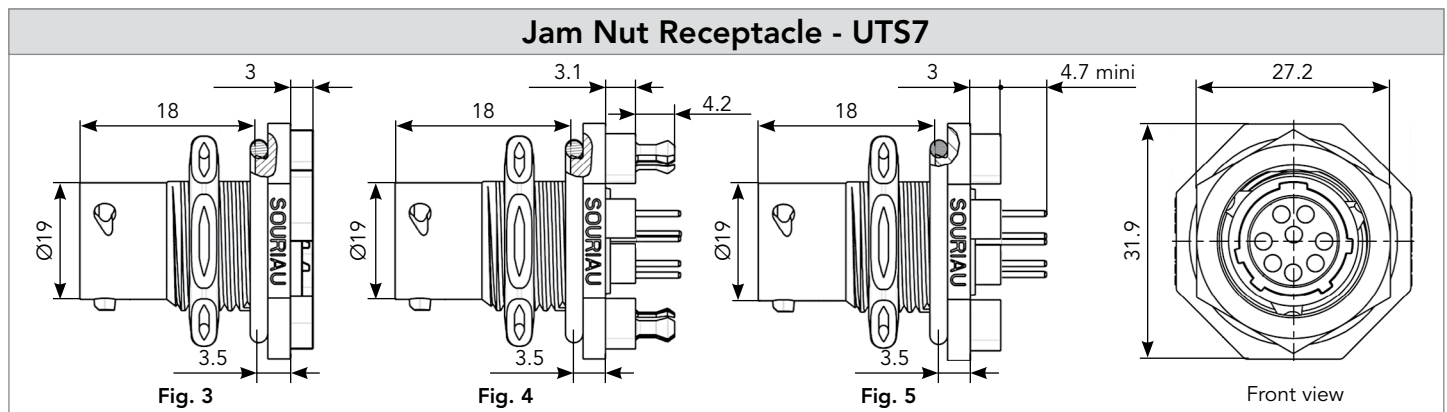
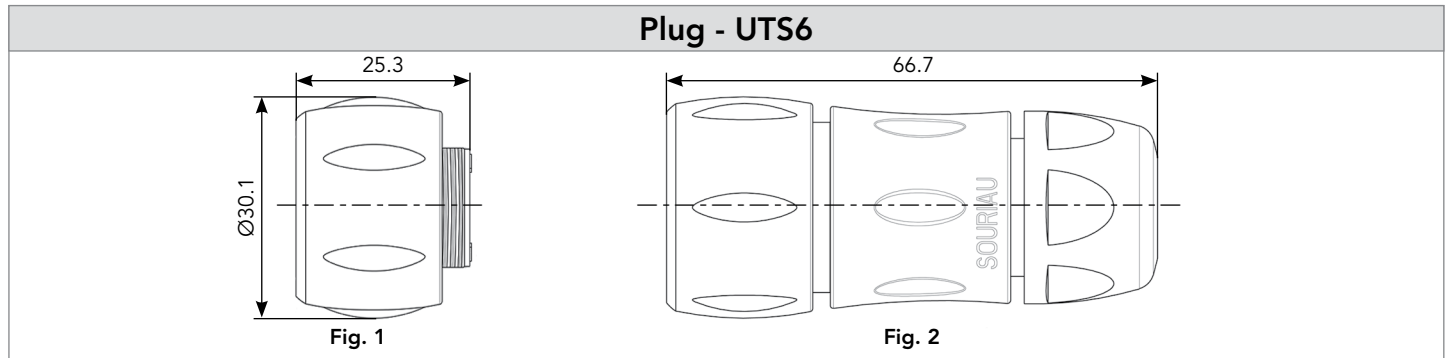

Note: Overmoulded cable assembly dimensions available page 179.

Note: all dimensions are in mm

12E8/12D8 (Shell size 12, 8x#20)

Accessories and Tooling

**Jam Nut Sealing Caps**



IP68/69K

Part number
UTS12DCG



IP68/69K Metal terminal

Part number
UTS12DCGR

**Plug Sealing Cap**



IP68/69K

Part number
UTS612DCG

**Square Flange Sealing Cap**



IP68/69K Metal terminal

Part number
UTS12DCGE

**Plastic Protective Cap**



Part numbers	
Receptacle cap	Plug cap
85005587A	85005596

**Gasket**



Part numbers
UTFD13B

**Color Coding Rings**

G for Green 

Y for Yellow 

R for Red 

Part numbers	
Receptacles	Plugs
UTS712CCRR	UTS612CCRR
UTS712CCRY	UTS612CCRY
UTS712CCRG	UTS612CCRG

## 12E8/12D8 (Shell size 12, 8x#20)

### Contacts

#20	Contact type	Plating	Cable acceptance (AWG)	Wire stripping length
Hand solder	Loaded in the connector	Min 0.4μ gold over 0.8μ Ni	22 to 18	5 mm
PCB	Machined <sup>(1)</sup>	Min 0.4μ gold over 0.8μ Ni	-	-

(1): For dimensions see page 169

**Electrical Characteristics**

**UL**  
4.5A 250V UL94 HB

**CSA**  
4.5A 250V UL94 HB

**IEC**  
6A 32V 1.5kV 3

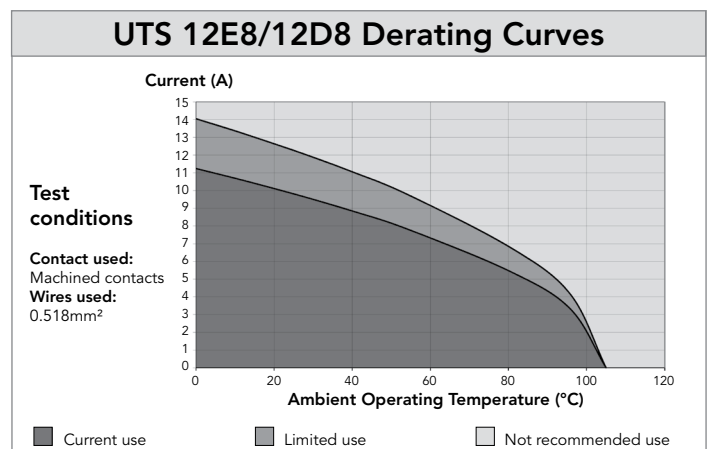

**148** (Shell size 14, 4x#16, 4x#12)

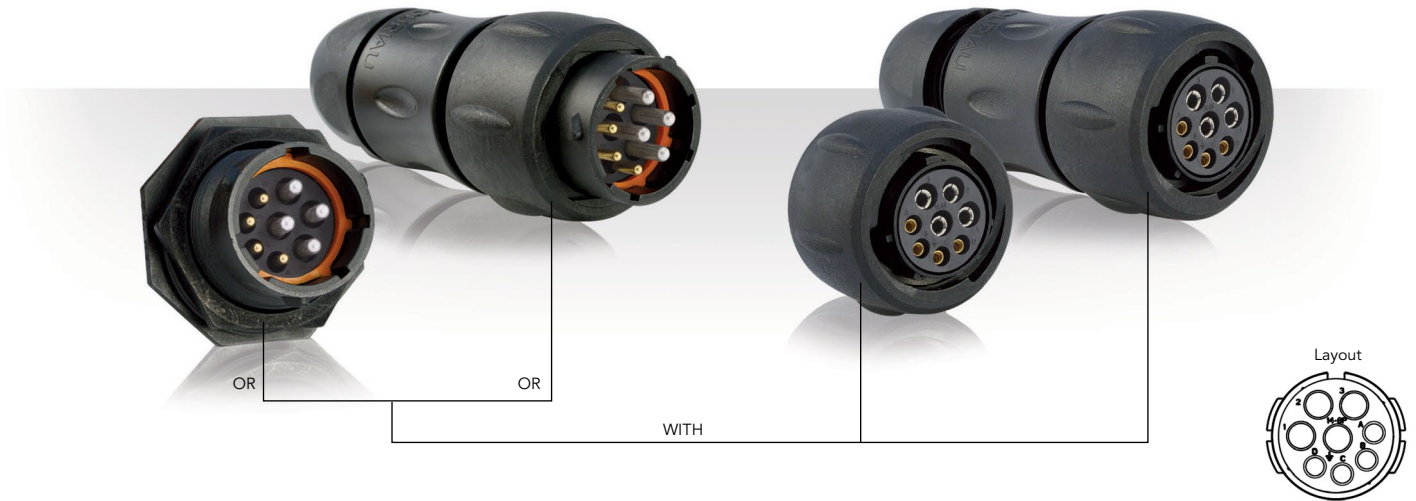

**Connector Part Numbers**

Contact type	Connector type	Backshell	Part number	
			Male insert	Female insert
Crimp contacts supplied separately see page 111	Free hanging receptacle	Cable gland (Fig. 1)	<b>UTS1JC148P</b>	<b>UTS1JC148S</b>
	Plug	Without (Fig. 2)	<b>UTS6148P</b>	<b>UTS6148S</b>
	Plug	Cable gland (Fig. 3)	<b>UTS6JC148P</b>	<b>UTS6JC148S</b>
	Jam nut receptacle	Without (Fig. 4)	<b>UTS7148P</b>	<b>UTS7148S</b>

148 (Shell size 14, 4x#16, 4x#12)

Dimensions

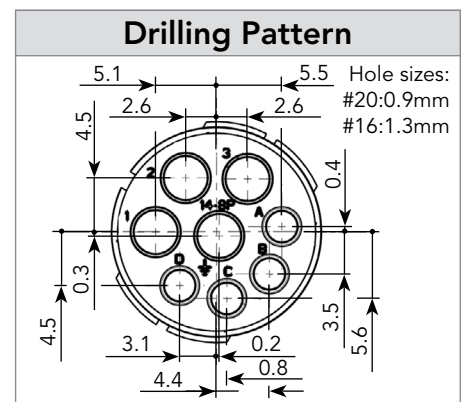
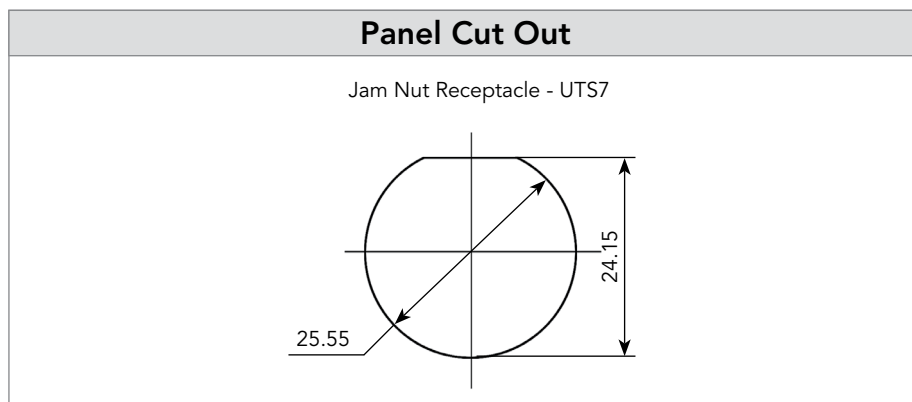
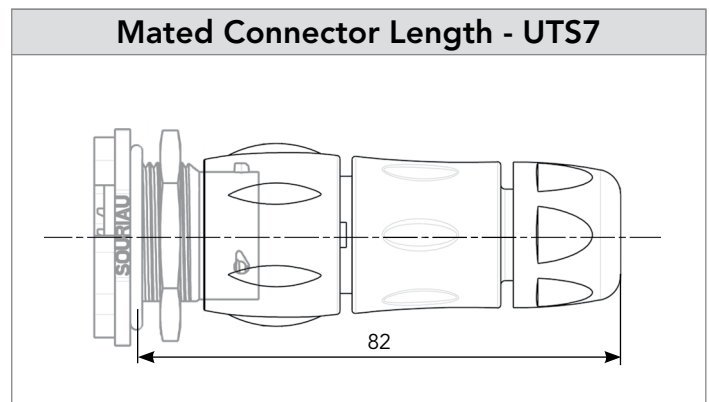
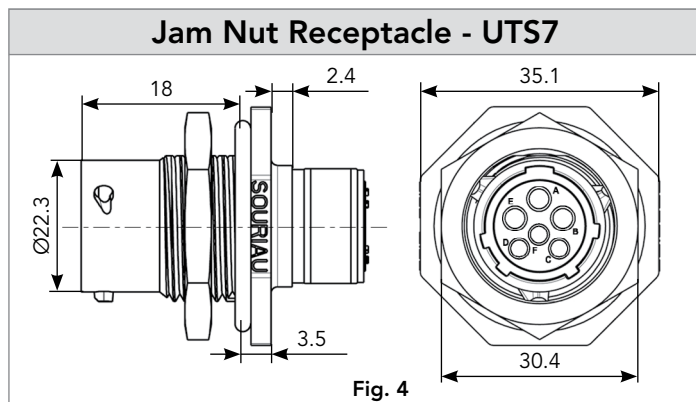
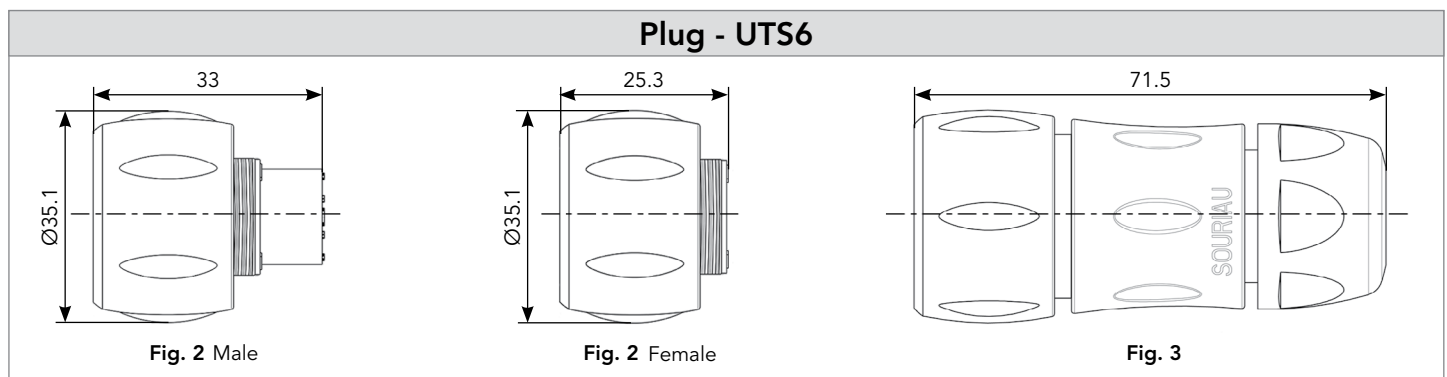
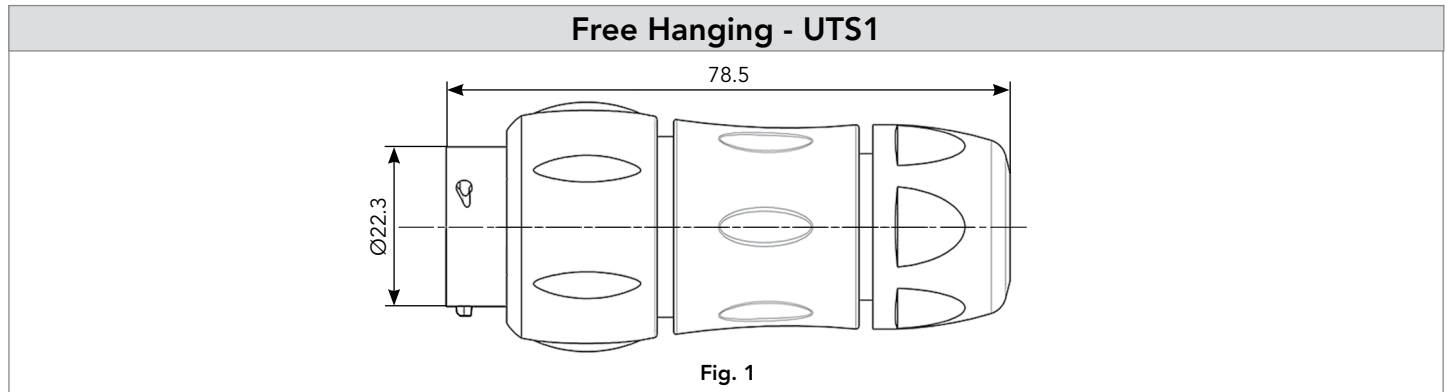

Note: all dimensions are in mm

148 (Shell size 14, 4x#16, 4x#12)

Accessories and Tooling

### Jam Nut Sealing Caps



IP68/69K

Part number
UTS14DCG



IP68/69K Metal terminal

Part number
UTS14DCGR

### Plug Sealing Cap



IP68/69K

Part number
UTS614DCG

### Square Flange Sealing Cap



IP68/69K Metal terminal

Part number
UTS14DCGE

### Plastic Protective Cap



Part numbers	
Receptacle cap	Plug cap
85005588A	85005597

### Gasket



Part numbers
UTFD14B

### Color Coding Rings

G for Green 

Y for Yellow 

R for Red 

Part numbers	
Receptacles	Plugs
UTS714CCRR	UTS614CCRR
UTS714CCRY	UTS614CCRY
UTS714CCRG	UTS614CCRG

### Extraction Tool



Part number
Extraction tool #12
51060210924



Part number
Extraction tool #16
VGE10078A

### Crimp Tooling #16



Part number
SHANDLES (without Head)



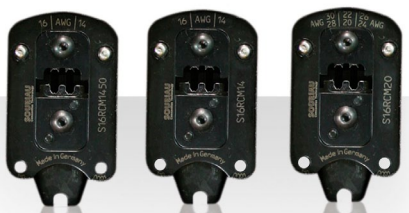

Part number
TOOLKIT



HEAD (without Shandles)

Contacts	Contact size	Part number of head
RM/RC 28M1K	Standard contacts #16 Ø 1.6mm	S16RCM20*
RM/RC 24M9K		S16RCM20*
RM/RC 20M13K		S16RCM20*
RM/RC 20M12K		S16RCM20*
RM/RC 16M23K		S16RCM16*
RM/RC 14M30K		S16RCM14*
SM/SC 24ML1TK6 <sup>(1)</sup>		S16SCM20*
SM/SC 20ML1TK6 <sup>(1)</sup>		S16SCM20*
SM/SC 16ML1TK6 <sup>(1)</sup>		S16SCML1*
SM/SC 14ML1TK6 <sup>(1)</sup>		S16SCML1*
SM/SC 16ML11TK6 <sup>(1)</sup>	S16SCML11*	

(1): Example of plating, for other plating see page 164  
\*: Heads to be used with handle PN: SHANDLES

+

=

Handle      Head      Complete set

### Crimp Tooling #12



Part number hand tool
M317



Part number positioner + locator setting
VGE10078A

148 (Shell size 14, 4x#16, 4x#12)

Contacts

#16	Contact type	AWG	Part number		Max wire Ø	Max insulator Ø
			Male	Female		
Crimp	Machined	30-28	RM28M1K <sup>(1)</sup>	RC28M1K <sup>(1)</sup>	0.55	1.00
		26-24	RM24M9K <sup>(1)</sup>	RC24M9K <sup>(1)</sup>	0.80	1.60
		22-20	RM20M13K <sup>(1)</sup>	RC20M13K <sup>(1)</sup>	1.15	1.80
		22-20	RM20M12K <sup>(1)</sup>	RC20M12K <sup>(1)</sup>	1.15	2.20
		20-16	RM16M23K <sup>(1)</sup>	RC16M23K <sup>(1)</sup>	1.80	3.20
		16-14	RM14M30K <sup>(1)</sup>	RC14M30K <sup>(1)</sup>	2.30	3.20
	Stamped & Formed reeled contacts See note (2) for loose piece	26-24	SM24M1TK6 <sup>(1)(2)</sup>	SC24M1TK6 <sup>(1)(2)</sup>	-	0.90-1.60
		22-20	SM20M1TK6 <sup>(1)(2)</sup>	SC20M1TK6 <sup>(1)(2)</sup>	-	1.20-2.10
		18-16	SM16M1TK6 <sup>(1)(2)</sup>	SC16M1TK6 <sup>(1)(2)</sup>	-	3.20
		18-16	SM16M11TK6 <sup>(1)(2)</sup>	SC16M11TK6 <sup>(1)(2)</sup>	-	3.00
14		SM14M1TK6 <sup>(1)(2)</sup>	SC14M1TK6 <sup>(1)(2)</sup>	-	3.20	
Coaxial	Cable Multipiece	see pages 167, 200 to 206	RMDXK10D28	RCDXK1D28	-	-
	Cable Monocrimp		RMDX60xxD28	RCDX60xxD28	-	-
	Twisted pair Multipiece		RMDXK10D28 + york090	RCDXK1D28 + york090	-	-
	Twisted pair Monocrimp		RMDX60xxD28	RCDX60xxD28	-	-
#12						
Crimp	Machined	22	82911457NA <sup>(1)</sup>	82911456A <sup>(1)</sup>	0.87	4.90
		20	82911459NA <sup>(1)</sup>	82911458A <sup>(1)</sup>	1.12	
		18	82911461NA <sup>(1)</sup>	82911460A <sup>(1)</sup>	1.42	
		16	82911463NA <sup>(1)</sup>	82911462A <sup>(1)</sup>	1.72	
		14	82911465NA <sup>(1)</sup>	82911464A <sup>(1)</sup>	2.22	
		12	82911467NA <sup>(1)</sup>	82911466A <sup>(1)</sup>	2.82	

(1): Example of plating, for other plating see page 164

(2): Loose piece contact available if putting L. Example: SM20ML1TK6

Note: all dimensions are in mm

8

### Electrical Characteristics

**UL**  
25A 250V UL94 V-0

**CSA**  
17A 230V UL94 V-0

**IEC**  
17A 230V 1.5kV 3

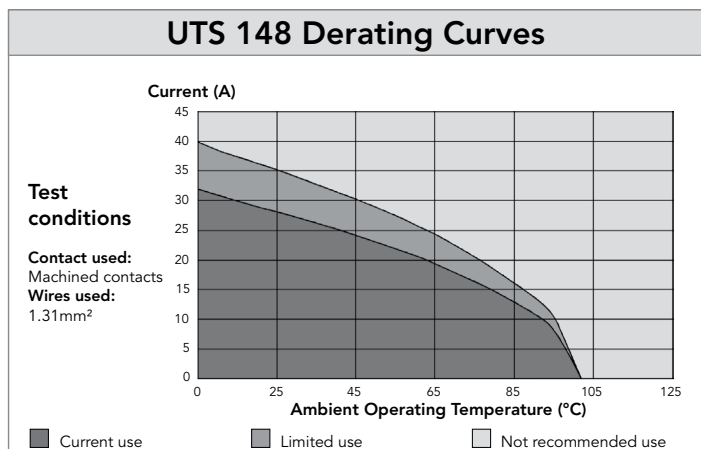

## 1210 - 12E10/12D10 (Shell size 12, 10x#20)

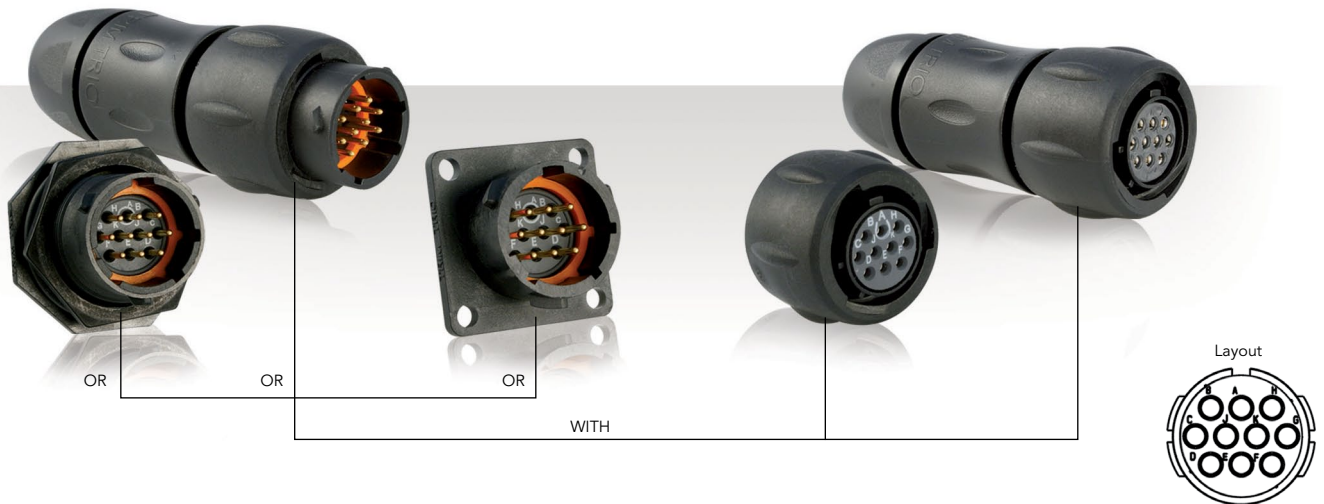

### Connector Part Numbers

Contact type	Connector type	Backshell	Part number	
			Male insert	Female insert
Crimp contacts supplied separately see page 115	Free hanging receptacle	Cable gland (Fig. 1)	<b>UTS1JC1210P</b>	<b>UTS1JC1210S</b>
	Plug	Without (Fig. 2)	<b>UTS61210P</b>	<b>UTS61210S</b>
	Plug	Cable gland (Fig. 3)	<b>UTS6JC1210P</b>	<b>UTS6JC1210S</b>
	Jam nut receptacle	Without (Fig. 4)	<b>UTS71210P</b>	<b>UTS71210S</b>
Hand solder electrical contacts loaded see page 115	Square flange receptacle	Without (Fig. 6)	<b>UTS012E10P</b>	<b>UTS012E10S</b>
	Plug	Without (Fig. 2)	<b>UTS612E10P</b>	<b>UTS612E10S</b>
		Cable gland (Fig. 3)	<b>UTS6JC12E10P</b>	<b>UTS6JC12E10S</b>
	Jam nut receptacle	Without (Fig. 5)	<b>UTS712E10P</b>	<b>UTS712E10S</b>
PCB contacts loaded see page 115	Square flange receptacle	Without (Fig. 7)	<b>UTS012D10P</b>	<b>UTS012D10S</b>
	Jam nut receptacle with stand off and with hold down clips	Without (Fig. 6)	<b>UTS712D10P32</b>	<b>UTS712D10S32</b>
	Jam nut receptacle with stand off and without hold down clip	Without (Fig. 7)	<b>UTS712D10P</b>	<b>UTS712D10S</b>

Possibilities of discrimination/keying methods see page 208

Sealed unmated

### Overmoulded Cable Assembly Part Numbers

Overmoulding type	Connector type	Wire size (mm <sup>2</sup> )	Harmonized cable part number <sup>(1)</sup>	Part number (length: 1m.)*	
				Male plug	Female plug
Straight ending	Plug	0.5	H05 VV - F 10x0.5	<b>HAUTS0V1210PST100</b>	<b>HAUTS0V1210SST100</b>
				<b>HAUTS0V12E10PST100</b>	<b>HAUTS0V12E10SST100</b>
Right angle ending	Plug	0.5	H05 VV - F 10x0.5	<b>HAUTS0V1210PRA100</b>	<b>HAUTS0V1210SRA100</b>
				<b>HAUTS0V12E10PRA100</b>	<b>HAUTS0V12E10SRA100</b>

(1) Other cable available on demand

\* Other lengths available on demand



1210 - 12E10/12D10 (Shell size 12, 10x#20)

Dimensions

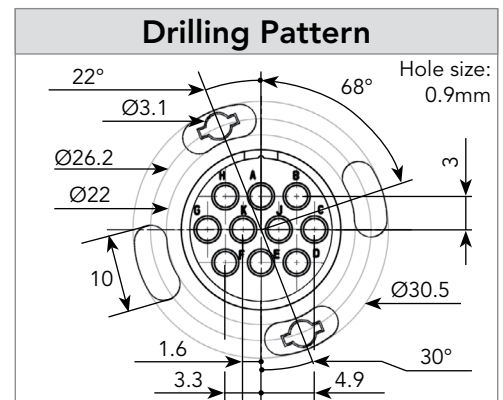
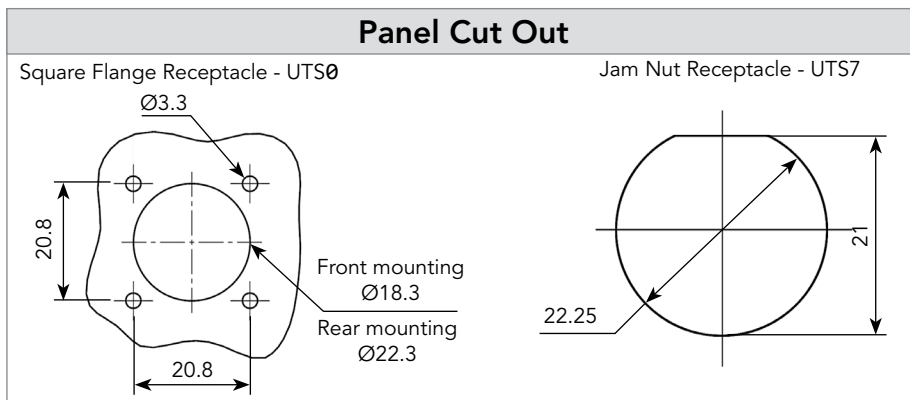
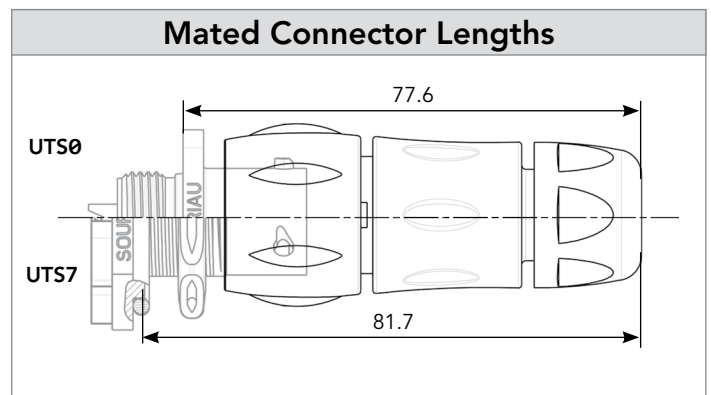
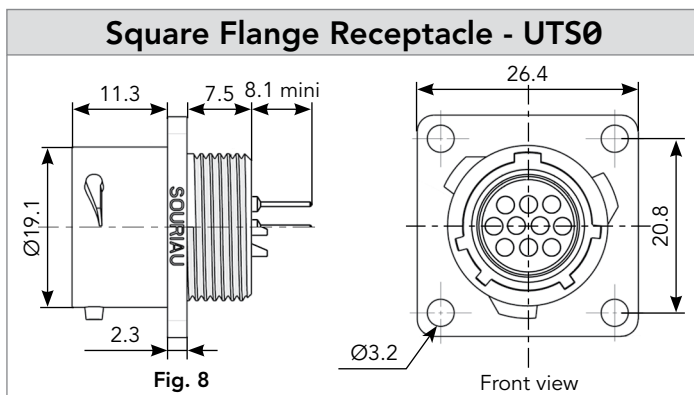
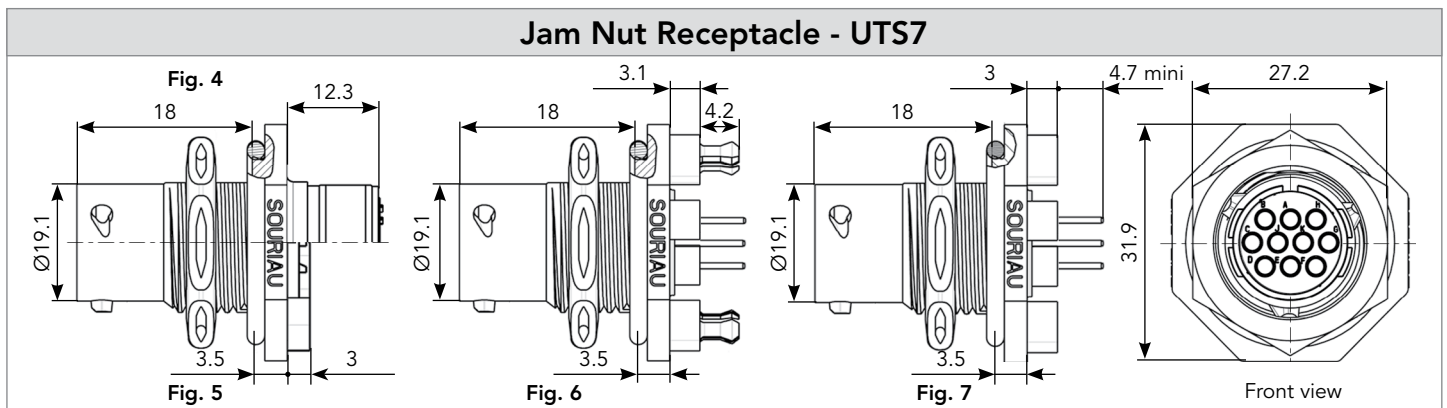
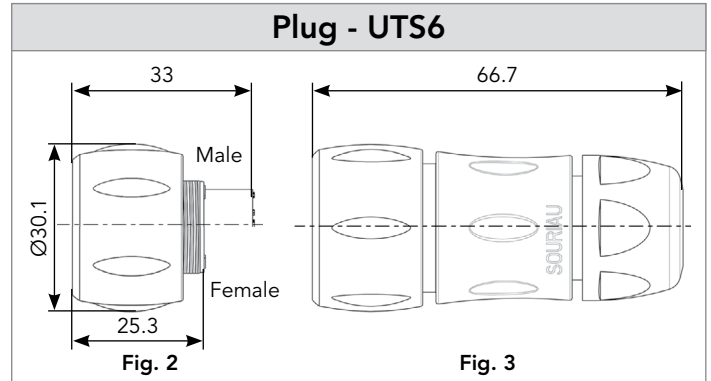
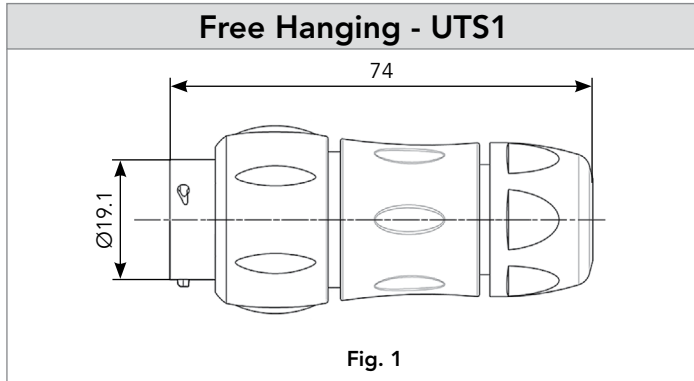

Note: Overmoulded cable assembly dimensions available page 179.

Note: all dimensions are in mm

# 1210 - 12E10/12D10 (Shell size 12, 10x#20)

## Accessories and Tooling

### Jam Nut Sealing Caps



IP68/69K

Part number
UTS12DCG



IP68/69K Metal terminal

Part number
UTS12DCGR

### Handle (without Head)



Part number
SHANDLES

### Tool Kit



Part number
TOOLKIT

### Plug Sealing Cap



IP68/69K

Part number
UTS612DCG

### Square Flange Sealing Cap



IP68/69K Metal terminal

Part number
UTS12DCGE

### Crimp Tooling (without Shandles)



Contacts	Contact size	Part number of head
RM/RC 24W3K <sup>(1)</sup>	Standard contacts #20 Ø 1mm	S20RCM*
RM/RC 20W3K <sup>(1)</sup>		S20RCM*
RM/RC 18W3K <sup>(1)</sup>		S20RCM*
SM/SC 24WL3S		S20SCM20*
SM/SC 20WL3S		S20SCM20*

(1): Example of plating, for other plating see page 164  
\*: Heads to be used with handle PN: SHANDLES

### Plastic Protective Cap



Part numbers	
Receptacle cap	Plug cap
85005587A	85005596

### Gasket



Part numbers
UTFD13B

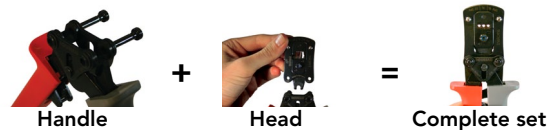

### Color Coding Rings

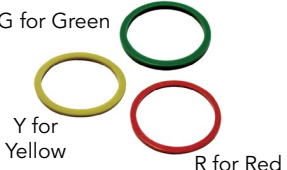

Part numbers	
Receptacles	Plugs
UTS712CCRR	UTS612CCRR
UTS712CCRY	UTS612CCRY
UTS712CCRG	UTS612CCRG

G for Green  
Y for Yellow  
R for Red

### Extraction Tool #20



Part number
RX20D44

# 1210 - 12E10/12D10 (Shell size 12, 10x#20)

## Contacts

#20	Contact type	Wire size		Part number		Max wire Ø	Max insulator Ø
		AWG	mm <sup>2</sup>	Male	Female		
Crimp	Machined	26-24	0.13-0.25	RM24W3K <sup>(1)</sup>	RC24W3K <sup>(1)</sup>	0.80	1.60
		22-20	0.32-0.52	RM20W3K <sup>(1)</sup>	RC20W3K <sup>(1)</sup>	1.15	1.60
		20-18	0.50-0.93	RM18W3K <sup>(1)</sup>	RC18W3K <sup>(1)</sup>	1.30	2.10
	Stamped & Formed reeled contacts See note (2) for loose piece	26-24	0.13-0.25	SM24W3TK6 <sup>(2)</sup>	SC24W3TK6 <sup>(2)</sup>	-	0.90-1.60
		26-24	0.13-0.25	SM24W3S26 <sup>(2)</sup>	SC24W3S25 <sup>(2)</sup>	-	0.90-1.60
		22-20	0.32-0.52	SM20W3TK6 <sup>(2)</sup>	SC20W3TK6 <sup>(2)</sup>	-	1.20-2.10
		22-20	0.32-0.52	SM20W3S26 <sup>(2)</sup>	SC20W3S25 <sup>(2)</sup>	-	1.20-2.10
	PCB	Machined <sup>(3)</sup>	-	-	RMW5016K	RCW5016K	-

(1): Example of plating, for other plating see page 164 (2): Loose piece contact available if putting L. Example: SM20WL3TK6 (3): For dimensions see page 168 Note: all dimensions are in mm

#20	Contact type	Plating	Cable acceptance (AWG)	Wire stripping length
Hand solder	Loaded in the connector	Min 0.4µ gold over 0.8µ Ni	22 to 18	3.8 mm

10

Electrical Characteristics	
<b>UTS 1210</b> <b>UL</b> 5A 250V UL94 V-0	<b>UTS 12E10/12D10</b> <b>UL</b> 4.5A 250V UL94 HB
<b>CSA</b> 4A 250V UL94 V-0	<b>CSA</b> 4.5A 250V UL94 HB
<b>IEC</b> 6A 50V 1.5kV 3	

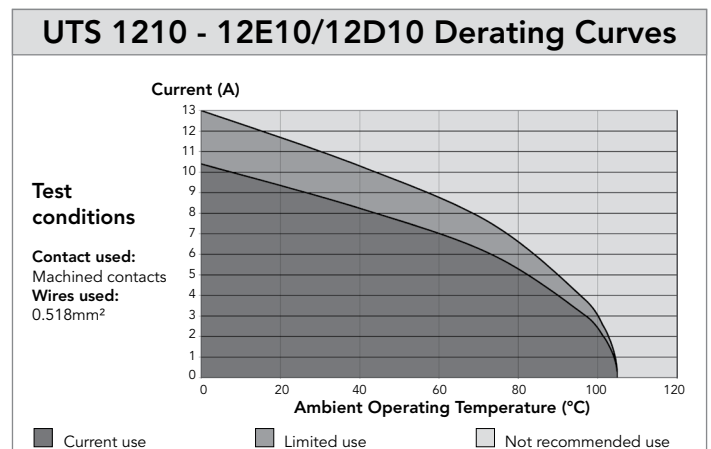

**1412** (Shell size 14, 12x#16)



**Connector Part Numbers**

Contact type	Connector type	Backshell	Part number	
			Male insert	Female insert
Crimp contacts supplied separately see page 119	Square flange receptacle	Without (Fig. 1)	<b>UTS01412P</b>	<b>UTS01412S</b>
	Free hanging receptacle	Cable gland and grommet (Fig. 2)	<b>UTS1GJC1412P</b>	-
	Free hanging receptacle	Nut and grommet (Fig. 3)	<b>UTS1GN1412P</b>	-
	Free hanging receptacle	Cable gland (Fig. 2)	<b>UTS1JC1412P</b>	<b>UTS1JC1412S</b>
	Plug	Without (Fig. 4)	<b>UTS61412P</b>	<b>UTS61412S</b>
	Plug	Cable gland and grommet (Fig. 5)	-	<b>UTS6GJC1412S</b>
	Plug	Nut and grommet (Fig. 6)	-	<b>UTS6GN1412S</b>
	Plug	Cable gland (Fig. 5)	<b>UTS6JC1412P</b>	<b>UTS6JC1412S</b>
	Jam nut receptacle	Without (Fig. 7)	<b>UTS71412P</b>	<b>UTS71412S</b>
	Jam nut receptacle	Cable gland and grommet (Fig. 9)	<b>UTS7GJC1412P</b>	-
	Jam nut receptacle	Nut and grommet (Fig. 8)	<b>UTS7GN1412P</b>	-
PCB contacts supplied separately see page 119	Square flange receptacle	Without (Fig. 1)	<b>UTS01412P</b>	<b>UTS01412S</b>
	Jam nut receptacle	Without (Fig. 7)	<b>UTS71412P</b>	<b>UTS71412S</b>

Possibilities of discrimination/keying methods see page 208

**Overmoulded Cable Assembly Part Numbers**

Overmoulding type	Connector type	Wire size (mm <sup>2</sup> )	Harmonized cable part number <sup>(1)</sup>	Part number (length: 1m.)*	
				Male plug	Female plug
Straight ending	Plug	1.5	H05 VV - F 12x1.5	<b>HAUTS0V1412PST100</b>	<b>HAUTS0V1412SST100</b>
Right angle ending	Plug	1.5	H05 VV - F 12x1.5	<b>HAUTS0V1412PRA100</b>	<b>HAUTS0V1412SRA100</b>

(1) Other cable available on demand

\* Other lengths available on demand

1412 (Shell size 14, 12x#16)

Dimensions

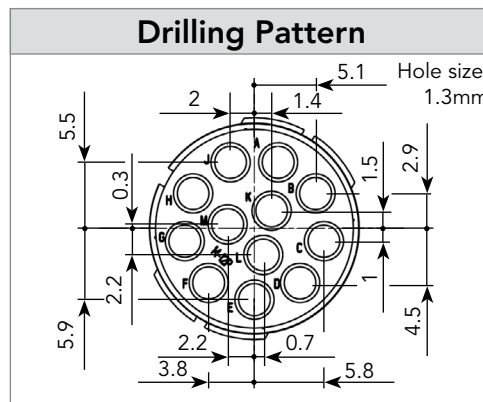
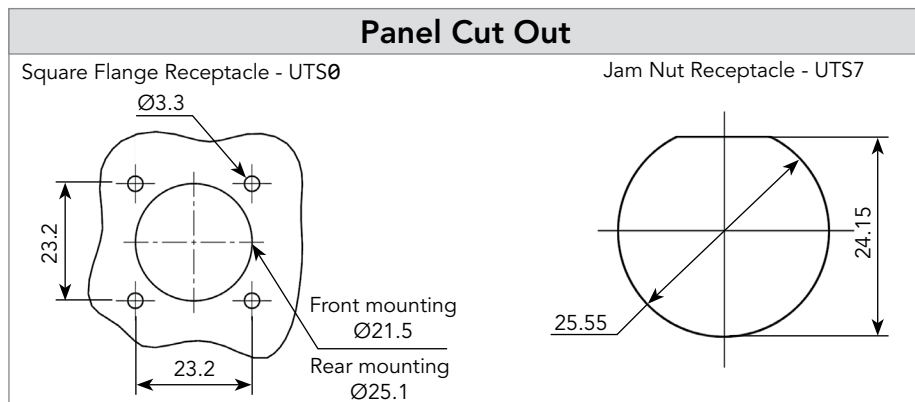
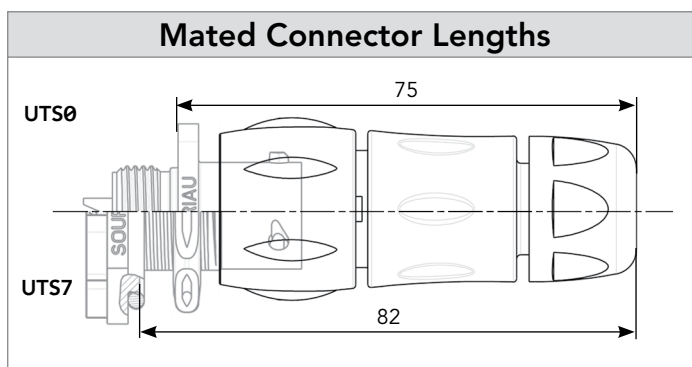
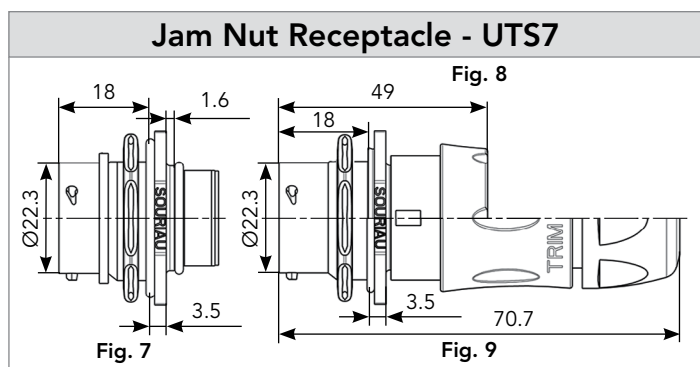
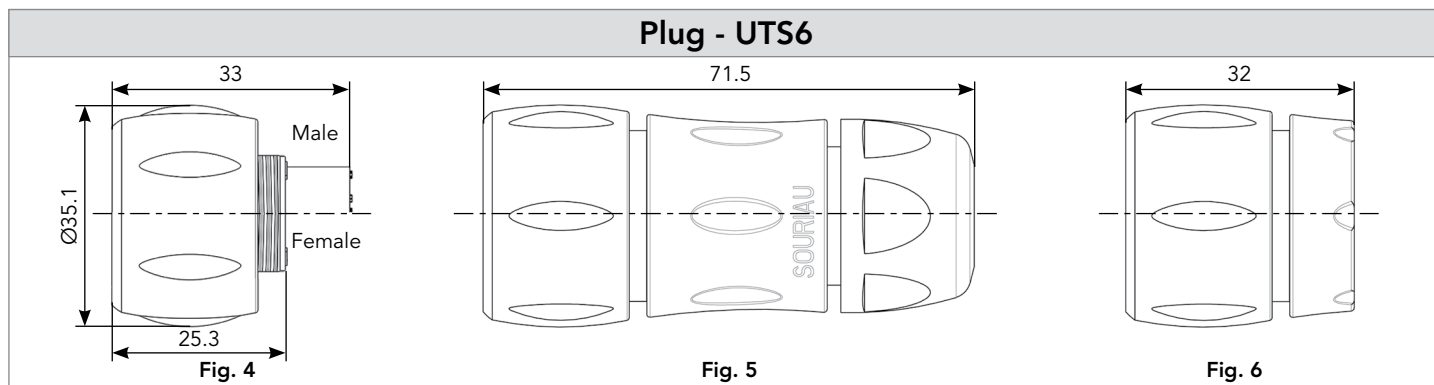
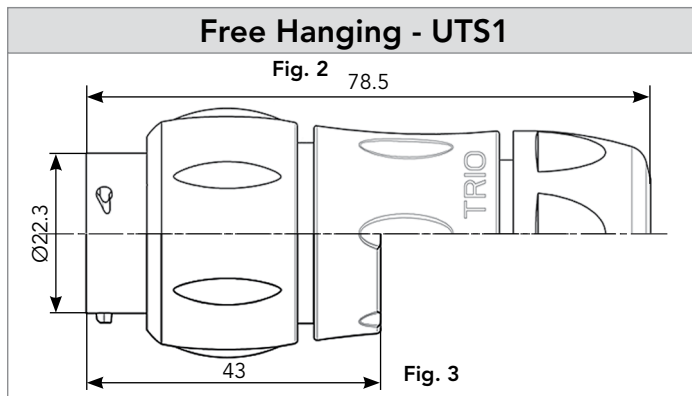
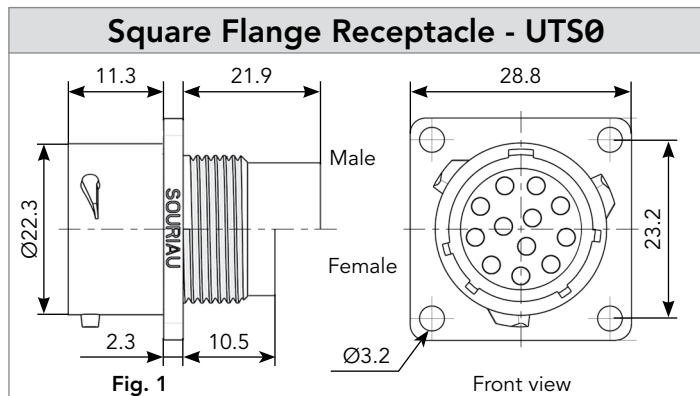

Note: Overmoulded cable assembly dimensions available page 179.

Note: all dimensions are in mm

# 1412 (Shell size 14, 12x#16)

## Accessories and Tooling

### Jam Nut Sealing Caps



IP68/69K

Part number
UTS14DCG



IP68/69K Metal terminal

Part number
UTS14DCGR

### Handle (without Head)



Part number
SHANDLES

### Tool Kit



Part number
TOOLKIT

### Plug Sealing Cap



IP68/69K

Part number
UTS614DCG

### Square Flange Sealing Cap



IP68/69K Metal terminal

Part number
UTS14DCGE

### Crimp Tooling (without Shandles)



Contacts	Contact size	Part number of head
RM/RC 28M1K <sup>(1)</sup>	Standard contacts #16 Ø 1.6mm	S16RCM20*
RM/RC 24M9K <sup>(1)</sup>		S16RCM20*
RM/RC 20M13K <sup>(1)</sup>		S16RCM20*
RM/RC 20M12K <sup>(1)</sup>		S16RCM20*
RM/RC 16M23K <sup>(1)</sup>		S16RCM16*
RM/RC 14M30K <sup>(1)</sup>		S16RCM14*
SM/SC 24ML1TK6 <sup>(1)</sup>		S16SCM20*
SM/SC 20ML1TK6 <sup>(1)</sup>		S16SCM20*
SM/SC 16ML1TK6 <sup>(1)</sup>		S16SCML1*
SM/SC 14ML1TK6 <sup>(1)</sup>		S16SCML1*
SM/SC 16ML11TK6 <sup>(1)</sup>		S16SCML11*
RMDXK10D28K		Coaxial contacts
RCDXK1D28K		
RM/RC DX60xxD28K		
RM/RC DXK10D28 + york090		
RM/RC DX60xxD28		

(1): Example of plating, for other plating options see page 164  
\* Heads to be used with handle PN: SHANDLES

### Plastic Protective Cap



Part numbers	
Receptacle cap	Plug cap
85005588A	85005597

### Gasket



Part numbers
UTFD14B

### Color Coding Rings

G for Green 

Y for Yellow 

R for Red 

Part numbers	
Receptacles	Plugs
UTS714CCR	UTS614CCR
UTS714CCR	UTS614CCR
UTS714CCR	UTS614CCR

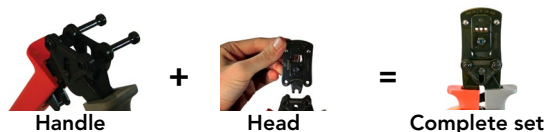

# 1412 (Shell size 14, 12x#16)

## Contacts

#16	Contact type	AWG	Part number		Max wire Ø	Max insulator Ø
			Male	Female		
Crimp	Machined	30-28	RM28M1K <sup>(1)</sup>	RC28M1K <sup>(1)</sup>	0.55	1.00
		26-24	RM24M9K <sup>(1)</sup>	RC24M9K <sup>(1)</sup>	0.80	1.60
		22-20	RM20M13K <sup>(1)</sup>	RC20M13K <sup>(1)</sup>	1.15	1.80
		22-20	RM20M12K <sup>(1)</sup>	RC20M12K <sup>(1)</sup>	1.15	2.20
		20-16	RM16M23K <sup>(1)</sup>	RC16M23K <sup>(1)</sup>	1.80	3.20
		16-14	RM14M30K <sup>(1)</sup>	RC14M30K <sup>(1)</sup>	2.30	3.20
	Stamped & Formed reeled contacts See note (2) for loose piece	26-24	SM24M1TK6 <sup>(1)(2)</sup>	SC24M1TK6 <sup>(1)(2)</sup>	-	0.90-1.60
		22-20	SM20M1TK6 <sup>(1)(2)</sup>	SC20M1TK6 <sup>(1)(2)</sup>	-	1.20-2.10
		18-16	SM16M1TK6 <sup>(1)(2)</sup>	SC16M1TK6 <sup>(1)(2)</sup>	-	3.20
		18-16	SM16M11TK6 <sup>(1)(2)</sup>	SC16M11TK6 <sup>(1)(2)</sup>	-	3.00
14		SM14M1TK6 <sup>(1)(2)</sup>	SC14M1TK6 <sup>(1)(2)</sup>	-	3.20	
PCB	Machined <sup>(3)</sup>	-	RM20M12E83K <sup>(1)</sup>	RC20M12E84K <sup>(1)</sup>	-	-
Coaxial	Cable Multipiece	see pages 167, 200 to 206	RMDXK10D28	RCDXK1D28	-	-
	Cable Monocrimp		RMDX60xxD28	RCDX60xxD28	-	-
	Twisted pair Multipiece		RMDXK10D28 + york090	RCDXK1D28 + york090	-	-
	Twisted pair Monocrimp		RMDX60xxD28	RCDX60xxD28	-	-
Fiber optic	POF contacts (Plastic Optical Fiber)	-	RMPOF1000	RCPOF1000B	-	-
Hand-solder	Loaded in the connector	14-18	-	-		

(1): Example of plating, for other plating see page 164 (2): Loose piece contact available if putting L. Example: SM20M1TK6 (3): For dimensions see page 168 Note: all dimensions are in mm

Electrical Characteristics
<p><b>UL</b> 10A 600V UL94 V-0</p> <p><b>CSA</b> 7A 600V UL94 V-0</p> <p><b>IEC</b> 10A 63V 1.5kV 3</p>

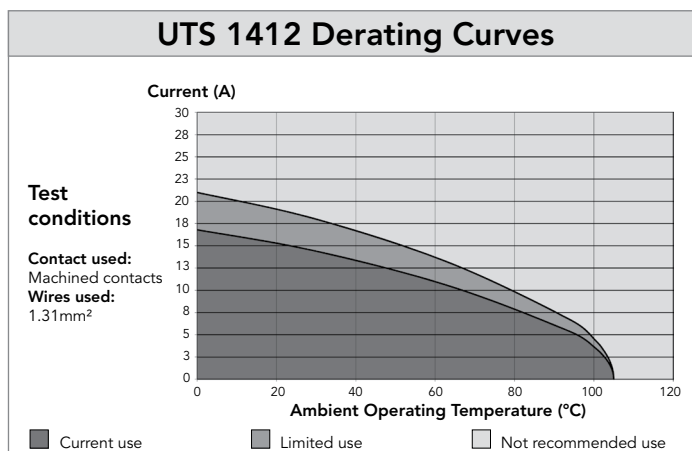

## 14E12/14D12 (Shell size 14, 8x#20, 4x#16)

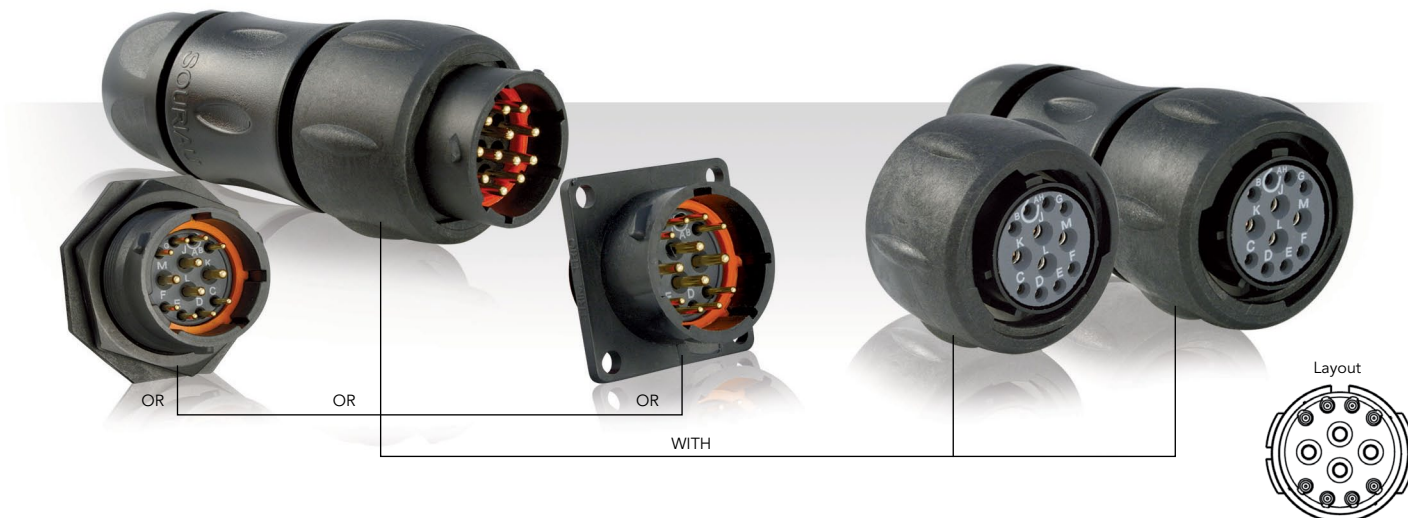

## Connector Part Numbers

Contact type	Connector type	Backshell	Part number	
			Male insert	Female insert
Hand solder electrical contacts loaded see page 123	Square flange receptacle	Without (Fig. 6)	<b>UTS014E12P</b>	<b>UTS014E12S</b>
	Plug	Without (Fig. 1)	<b>UTS614E12P</b>	<b>UTS614E12S</b>
		Cable gland (Fig. 2)	<b>UTS6JC14E12P</b>	<b>UTS6JC14E12S</b>
	Jam nut receptacle	Without (Fig. 3)	<b>UTS714E12P</b>	<b>UTS714E12S</b>
PCB contacts loaded see page 123	Square flange receptacle	Without (Fig. 6)	<b>UTS014D12P</b>	<b>UTS014D12S</b>
	Jam nut receptacle with stand off and with hold down clips	Without (Fig. 4)	<b>UTS714D12P32</b>	<b>UTS714D12S32</b>
	Jam nut receptacle with stand off and without hold down clip	Without (Fig. 5)	<b>UTS714D12P</b>	<b>UTS714D12S</b>

Possibilities of discrimination/keying methods see page 208

Sealed unmatad

## Overmoulded Cable Assembly Part Numbers

Overmoulding type	Connector type	Wire size (mm <sup>2</sup> )	Harmonized cable part number <sup>(1)</sup>	Part number (length: 1m.)*	
				Male plug	Female plug
Straight ending	Plug	1.5	H05 VV - F 12x1.5	<b>HAUTS0V14E12PST100</b>	<b>HAUTS0V14E12SST100</b>
Right angle ending	Plug	1.5	H05 VV - F 12x1.5	<b>HAUTS0V14E12PRA100</b>	<b>HAUTS0V14E12SRA100</b>

(1) Other cable available on demand

\* Other lengths available on demand



14E12/14D12 (Shell size 14, 8x#20, 4x#16)

Dimensions

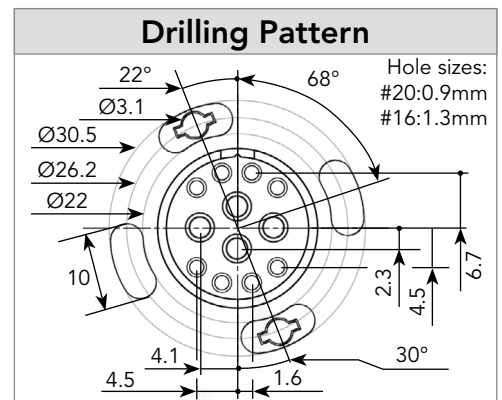
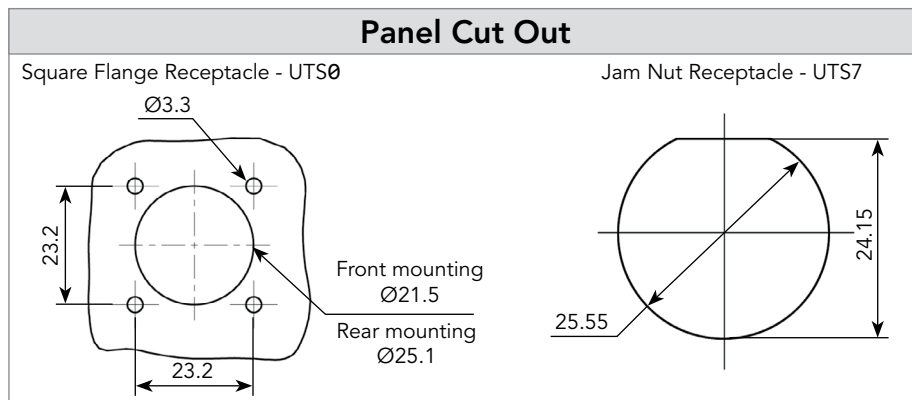
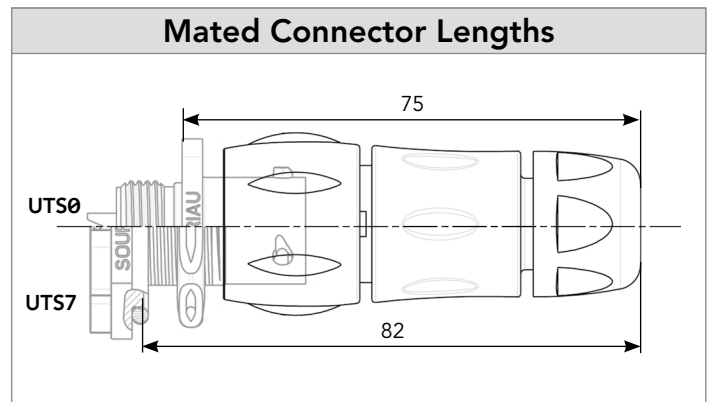
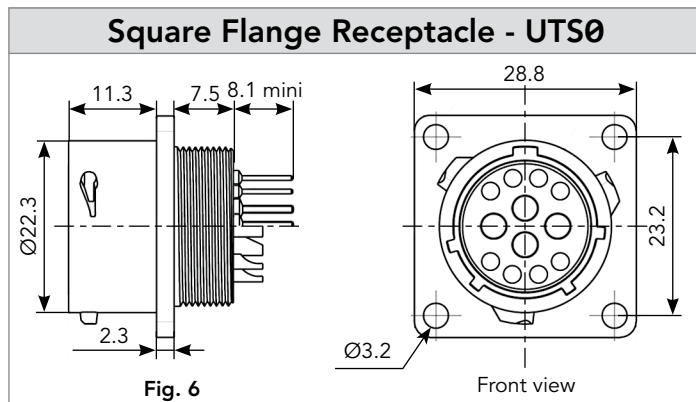
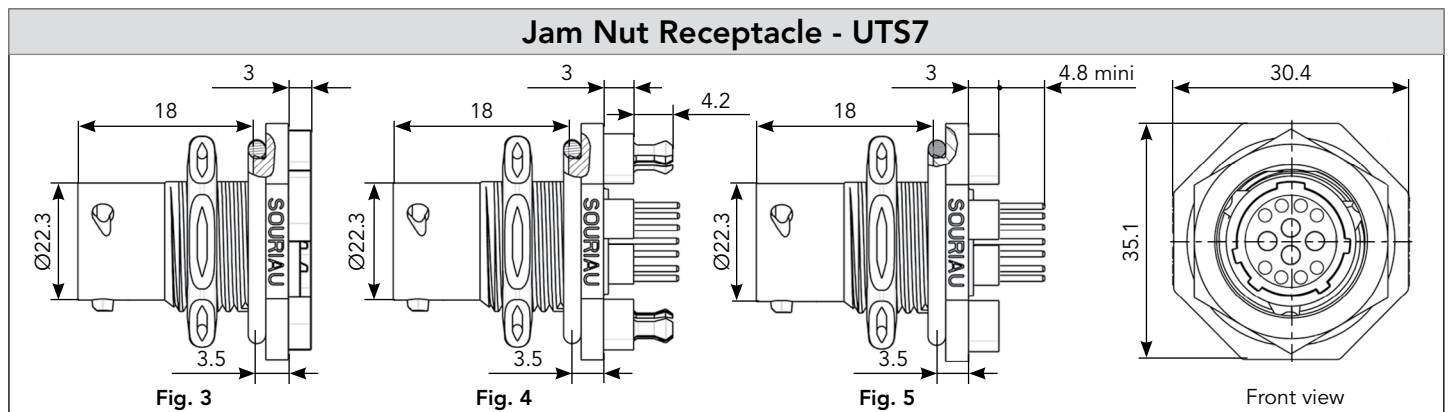
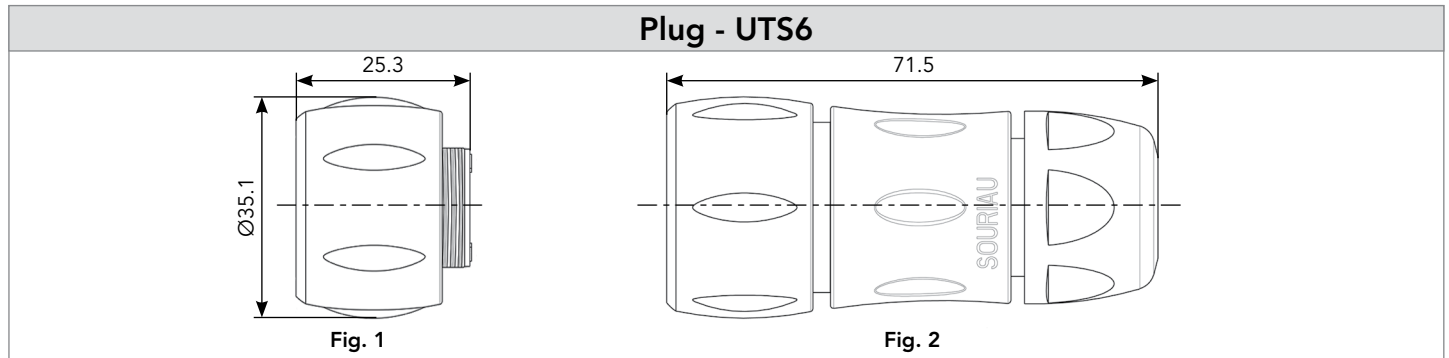

Note: Overmoulded cable assembly dimensions available page 179.

Note: all dimensions are in mm

14E12/14D12 (Shell size 14, 8x#20, 4x#16)

Accessories and Tooling

**Jam Nut Sealing Caps**



IP68/69K

Part number	
UTS14DCG	



IP68/69K Metal terminal

Part number	
UTS14DCGR	

**Plug Sealing Cap**



IP68/69K

Part number	
UTS614DCG	

**Square Flange Sealing Cap**



IP68/69K Metal terminal

Part number	
UTS14DCGE	

**Plastic Protective Cap**



Part numbers	
Receptacle cap	Plug cap
85005588A	85005597

**Gasket**



Part numbers	
UTFD14B	

**Color Coding Rings**

G for Green 

Y for Yellow 

R for Red 

Part numbers	
Receptacles	Plugs
UTS714CCRR	UTS614CCRR
UTS714CCRY	UTS614CCRY
UTS714CCRG	UTS614CCRG

## 14E12/14D12 (Shell size 14, 8x#20, 4x#16)

### Contacts

#16	Contact type	Plating	Cable acceptance (AWG)	Wire stripping length
Hand solder	Loaded in the connector	Min 0.4μ gold over 0.8μ Ni	18 to 14	5.0 mm
PCB	Machined <sup>(1)</sup>	Min 0.4μ gold over 0.8μ Ni	-	-
#20	Contact type	Plating	Cable acceptance (AWG)	Wire stripping length
Hand solder	Loaded in the connector	Min 0.4μ gold over 0.8μ Ni	22 to 18	3.8 mm
PCB	Machined <sup>(1)</sup>	Min 0.4μ gold over 0.8μ Ni	-	-

(1): For dimensions see page 169

Electrical Characteristics
<p><b>UL</b> 4.5A 250V UL94 HB</p> <p><b>CSA</b> 4.5A 250V UL94 HB</p> <p><b>IEC</b> 4A 50V 1.5kV 3</p>

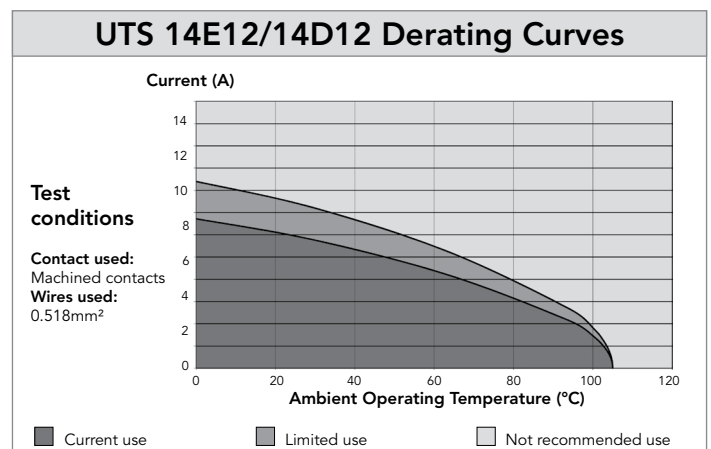

**1492** (Shell size 14, 12x#16)



**Connector Part Numbers**

Contact type	Connector type	Backshell	Part number	
			Male insert	Female insert
Crimp contacts supplied separately see page 127	Square flange receptacle	Without (Fig. 1)	<b>UTS01492P</b>	<b>UTS01492S</b>
	Free hanging receptacle	Cable gland and grommet (Fig. 2)	<b>UTS1GJC1492P</b>	-
	Free hanging receptacle	Nut and grommet (Fig. 3)	<b>UTS1GN1492P</b>	-
	Free hanging receptacle	Cable gland (Fig. 2)	<b>UTS1JC1492P</b>	<b>UTS1JC1492S</b>
	Plug	Without (Fig. 4)	<b>UTS61492P</b>	<b>UTS61492S</b>
	Plug	Cable gland and grommet (Fig. 5)	-	<b>UTS6GJC1492S</b>
	Plug	Nut and grommet (Fig. 6)	-	<b>UTS6GN1492S</b>
	Plug	Cable gland (Fig. 5)	<b>UTS6JC1492P</b>	<b>UTS6JC1492S</b>
	Jam nut receptacle	Without (Fig. 7)	<b>UTS71492P</b>	<b>UTS71492S</b>
	Jam nut receptacle	Cable gland and grommet (Fig. 9)	<b>UTS7GJC1492P</b>	-
	Jam nut receptacle	Nut and grommet (Fig. 8)	<b>UTS7GN1492P</b>	-
PCB contacts supplied separately see page 127	Square flange receptacle	Without (Fig. 1)	<b>UTS01492P</b>	<b>UTS01492S</b>
	Jam nut receptacle	Without (Fig. 7)	<b>UTS71492P</b>	<b>UTS71492S</b>

Possibilities of discrimination/keying methods see page 208

1492 (Shell size 14, 12x#16)

Dimensions

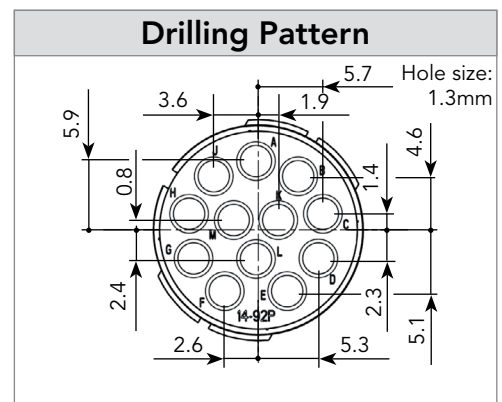
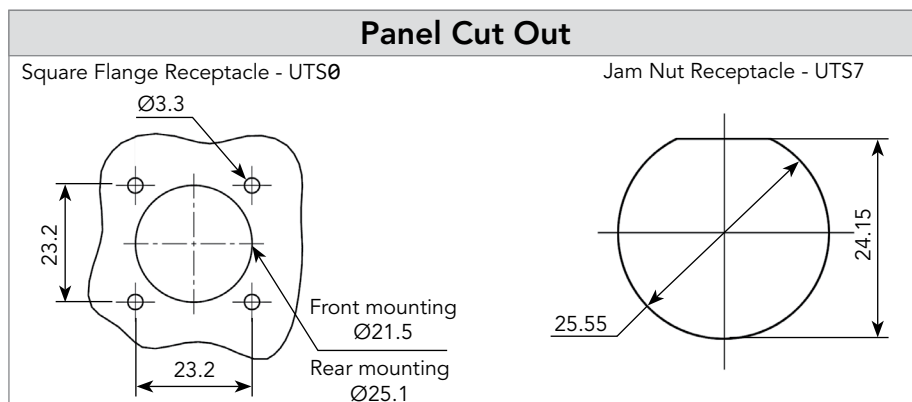
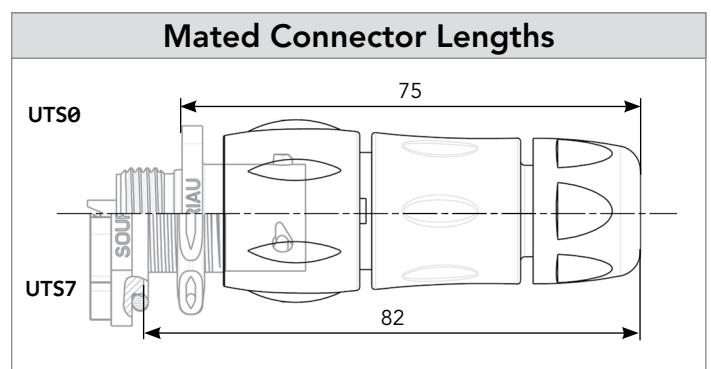
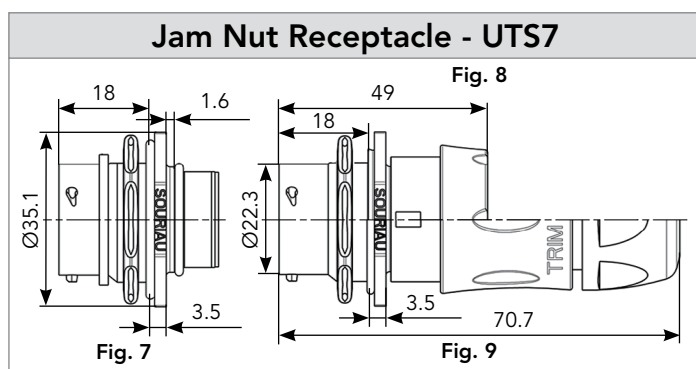
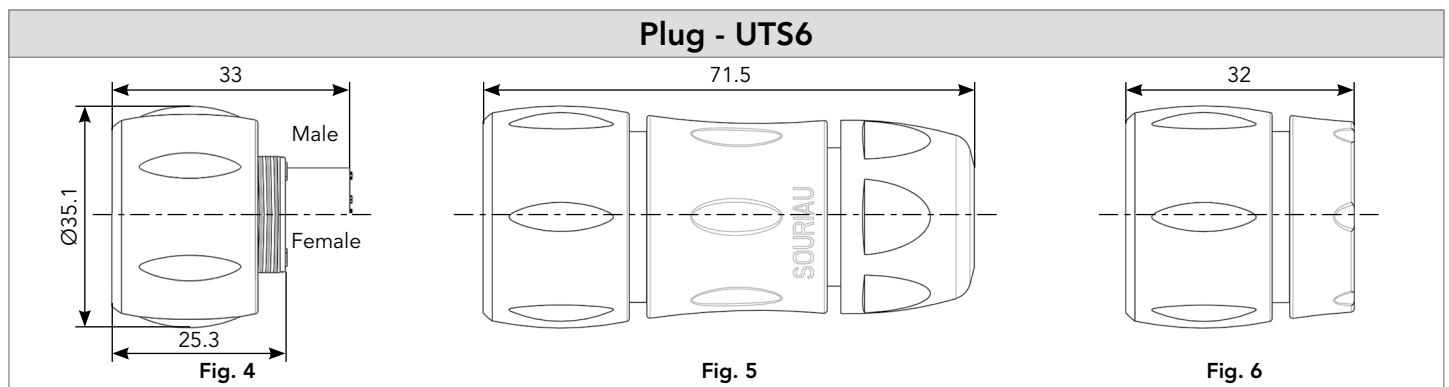
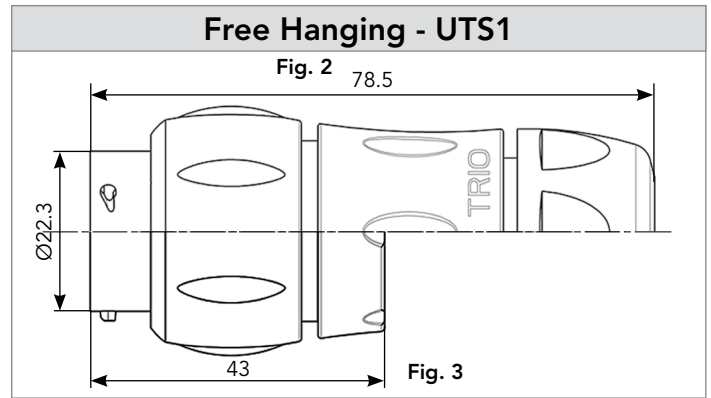
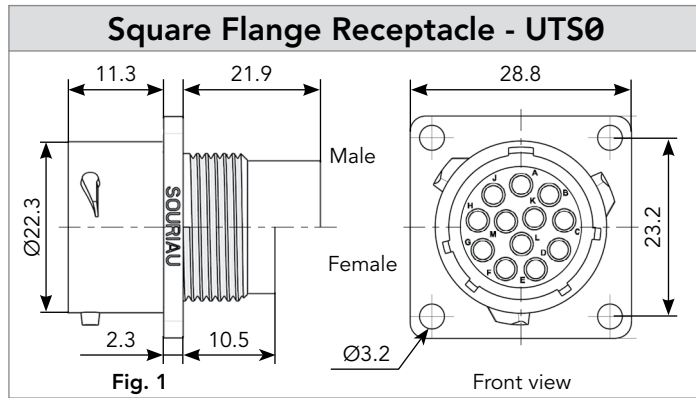

Note: all dimensions are in mm

1492 (Shell size 14, 12x#16)

## Accessories and Tooling

### Jam Nut Sealing Caps



IP68/69K

Part number
UTS14DCG



IP68/69K Metal terminal

Part number
UTS14DCGR

### Handle (without Head)



Part number
SHANDLES

### Tool Kit



Part number
TOOLKIT

### Plug Sealing Cap



IP68/69K

Part number
UTS614DCG

### Square Flange Sealing Cap



IP68/69K Metal terminal

Part number
UTS14DCGE

### Crimp Tooling (without Shandles)



Contacts	Contact size	Part number of head	
RM/RC 28M1K <sup>(1)</sup>	Standard contacts #16 Ø 1.6mm	S16RCM20*	
RM/RC 24M9K <sup>(1)</sup>		S16RCM20*	
RM/RC 20M13K <sup>(1)</sup>		S16RCM20*	
RM/RC 20M12K <sup>(1)</sup>		S16RCM20*	
RM/RC 16M23K <sup>(1)</sup>		S16RCM16*	
RM/RC 14M30K <sup>(1)</sup>		S16RCM14*	
SM/SC 24ML1TK6 <sup>(1)</sup>		S16SCM20*	
SM/SC 20ML1TK6 <sup>(1)</sup>		S16SCM20*	
SM/SC 16ML1TK6 <sup>(1)</sup>		S16SCML1*	
SM/SC 14ML1TK6 <sup>(1)</sup>		S16SCML1*	
SM/SC 16ML11TK6 <sup>(1)</sup>		S16SCML11*	
RMDXK10D28K		Coaxial contacts	M10S1J with die set & stop bushing see page 200 to 204
RCDXK1D28K			
RM/RC DX60xxD28K			
RM/RC DXK10D28 + york090			
RM/RC DX60xxD28			

(1): Example of plating, for other plating options see page 164  
\* Heads to be used with handle PN: SHANDLES

### Plastic Protective Cap



Part numbers	
Receptacle cap	Plug cap
85005588A	85005597

### Gasket



Part numbers
UTFD14B

### Color Coding Rings

G for Green 

Y for Yellow 

R for Red 

Part numbers	
Receptacles	Plugs
UTS714CCR	UTS614CCR
UTS714CCR	UTS614CCR
UTS714CCR	UTS614CCR



# 1492 (Shell size 14, 12x#16)

## Contacts

#16	Contact type	AWG	Part number		Max wire Ø	Max insulator Ø
			Male	Female		
Crimp	Machined	30-28	RM28M1K <sup>(1)</sup>	RC28M1K <sup>(1)</sup>	0.55	1.00
		26-24	RM24M9K <sup>(1)</sup>	RC24M9K <sup>(1)</sup>	0.80	1.60
		22-20	RM20M13K <sup>(1)</sup>	RC20M13K <sup>(1)</sup>	1.15	1.80
		22-20	RM20M12K <sup>(1)</sup>	RC20M12K <sup>(1)</sup>	1.15	2.20
		20-16	RM16M23K <sup>(1)</sup>	RC16M23K <sup>(1)</sup>	1.80	3.20
		16-14	RM14M30K <sup>(1)</sup>	RC14M30K <sup>(1)</sup>	2.30	3.20
	Stamped & Formed reeled contacts See note (2) for loose piece	26-24	SM24M1TK6 <sup>(1)(2)</sup>	SC24M1TK6 <sup>(1)(2)</sup>	-	0.90-1.60
		22-20	SM20M1TK6 <sup>(1)(2)</sup>	SC20M1TK6 <sup>(1)(2)</sup>	-	1.20-2.10
		18-16	SM16M1TK6 <sup>(1)(2)</sup>	SC16M1TK6 <sup>(1)(2)</sup>	-	3.20
		18-16	SM16M11TK6 <sup>(1)(2)</sup>	SC16M11TK6 <sup>(1)(2)</sup>	-	3.00
14		SM14M1TK6 <sup>(1)(2)</sup>	SC14M1TK6 <sup>(1)(2)</sup>	-	3.20	
PCB	Machined <sup>(3)</sup>	-	RM20M12E83K <sup>(1)</sup>	RC20M12E84K <sup>(1)</sup>	-	-
Coaxial	Cable Multipiece	see pages 167, 200 to 206	RMDXK10D28	RCDXK1D28	-	-
	Cable Monocrimp		RMDX60xxD28	RCDX60xxD28	-	-
	Twisted pair Multipiece		RMDXK10D28 + york090	RCDXK1D28 + york090	-	-
	Twisted pair Monocrimp		RMDX60xxD28	RCDX60xxD28	-	-
Fiber optic	POF contacts (Plastic Optical Fiber)	-	RMPOF1000	RCPOF1000B	-	-
Hand-solder	Loaded in the connector	14-18	-	-		

(1): Example of plating, for other plating see page 164 (2): Loose piece contact available if putting L. Example: SM20M1TK6 (3): For dimensions see page 168 Note: all dimensions are in mm

Electrical Characteristics
<p><b>UL</b> 10A 600V UL94 V-0</p> <p><b>CSA</b> 7A 600V UL94 V-0</p> <p><b>IEC</b> 10A 63V 1.5kV 3</p>

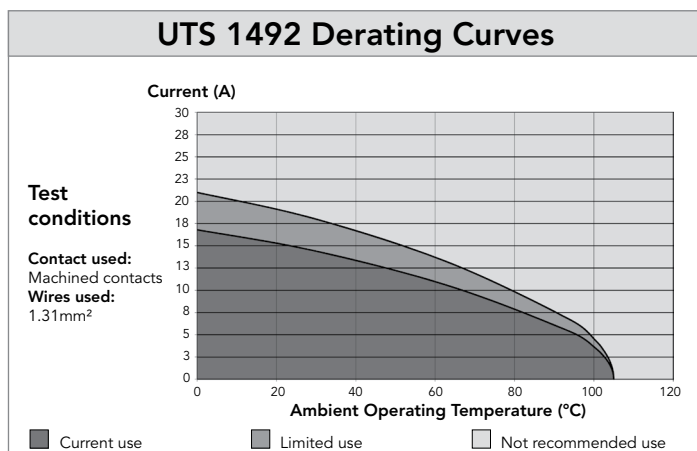

## 12E14/12D14 (Shell size 12, 14x#20)

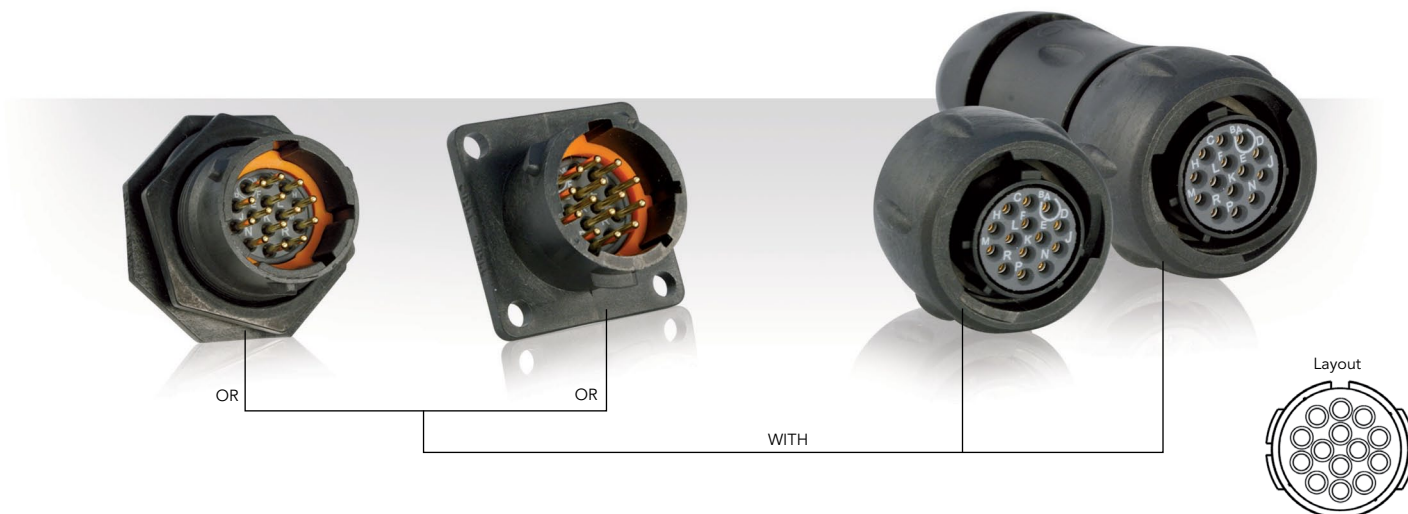

### Connector Part Numbers

Contact type	Connector type	Backshell	Part number	
			Male insert	Female insert
Hand solder electrical contacts loaded see page 131	Square flange receptacle	Without (Fig. 6)	<b>UTS012E14P</b>	<b>UTS012E14S</b>
	Plug	Without (Fig. 1)	<b>UTS612E14P</b>	<b>UTS612E14S</b>
		Cable gland (Fig. 2)	<b>UTS6JC12E14P</b>	<b>UTS6JC12E14S</b>
	Jam nut receptacle	Without (Fig. 3)	<b>UTS712E14P</b>	<b>UTS712E14S</b>
PCB contacts loaded see page 131	Square flange receptacle	Without (Fig. 7)	<b>UTS012D14P</b>	<b>UTS012D14S</b>
	Jam nut receptacle with stand off and with hold down clips	Without (Fig. 4)	<b>UTS712D14P32</b>	<b>UTS712D14S32</b>
	Jam nut receptacle with stand off and without hold down clip	Without (Fig. 5)	<b>UTS712D14P</b>	<b>UTS712D14S</b>

Possibilities of discrimination/keying methods see page 208

Sealed unmated

### Overmoulded Cable Assembly Part Numbers

Overmoulding type	Connector type	Wire size (mm <sup>2</sup> )	Harmonized cable part number <sup>(1)</sup>	Part number (length: 1m.)*	
				Male plug	Female plug
Straight ending	Plug	0.5	H05 VV - F 14x0.5	<b>HAUTS0V12E14PST100</b>	<b>HAUTS0V12E14SST100</b>
Right angle ending	Plug	0.5	H05 VV - F 14x0.5	<b>HAUTS0V12E14PRA100</b>	<b>HAUTS0V12E14SRA100</b>

(1) Other cable available on demand

\* Other lengths available on demand



12E14/12D14 (Shell size 12, 14x#20)

Dimensions

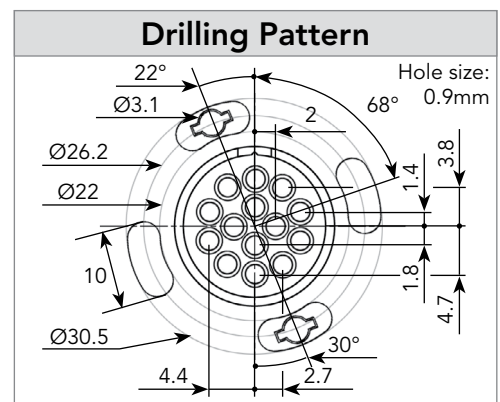
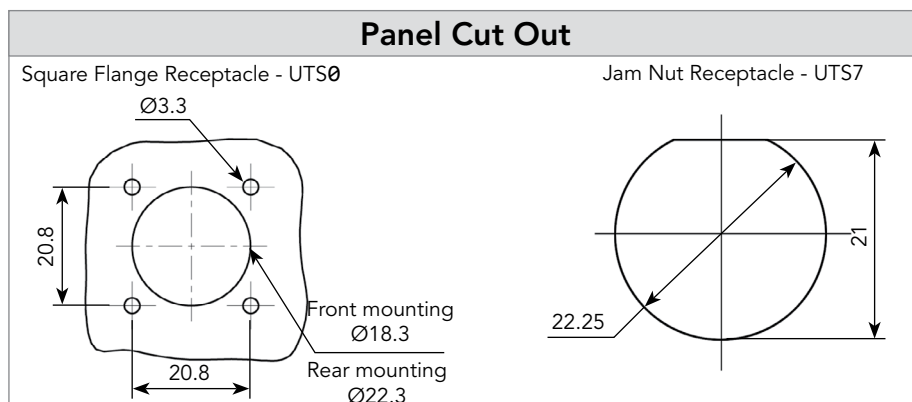
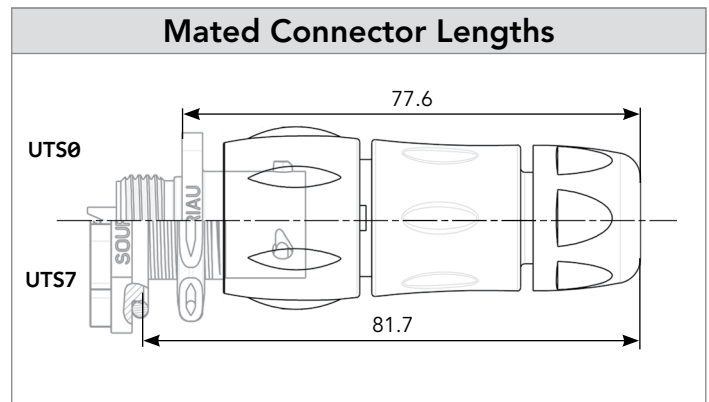
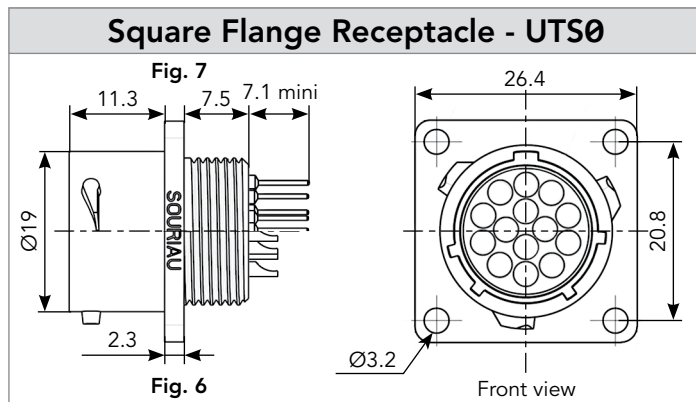
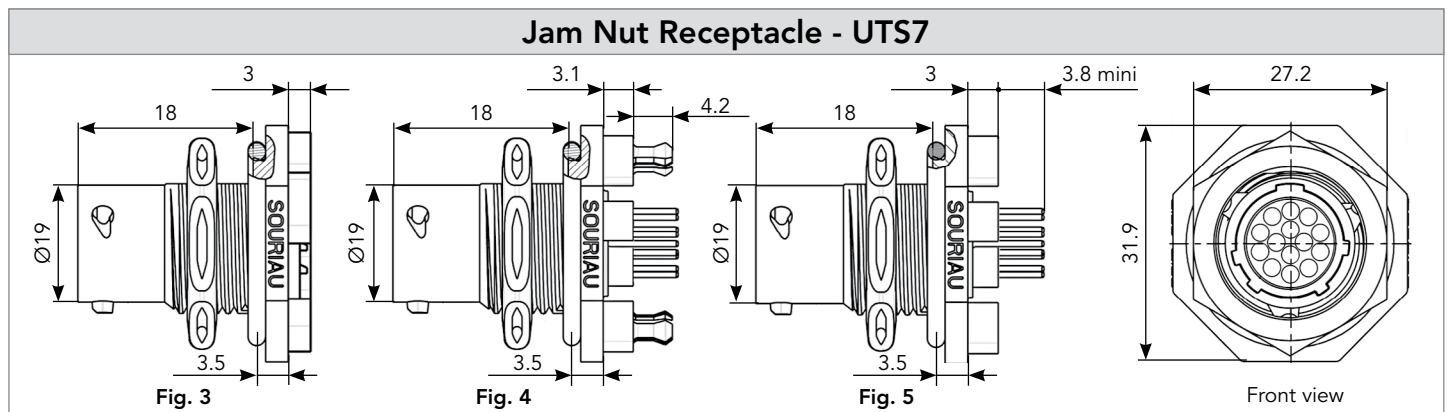
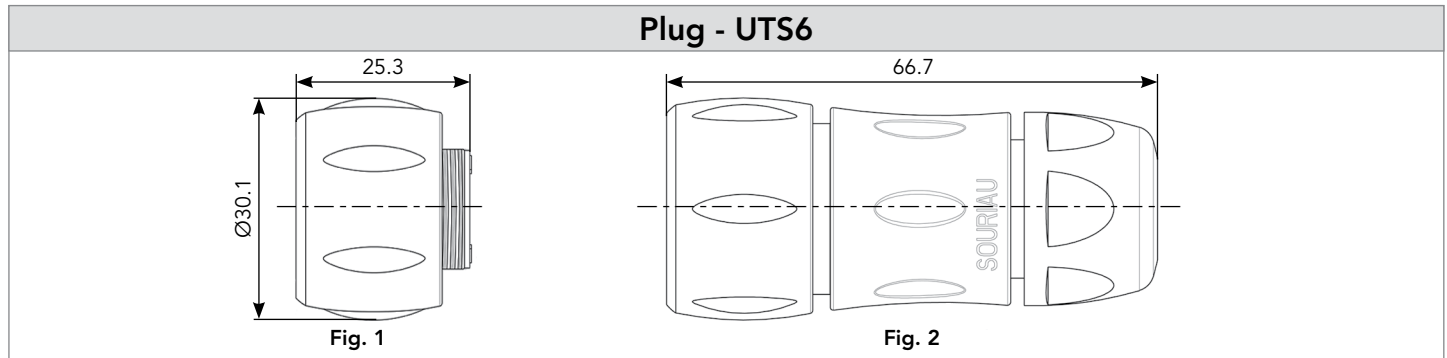

Note: Overmoulded cable assembly dimensions available page 179.

Note: all dimensions are in mm

12E14/12D14 (Shell size 12, 14x#20)

Accessories and Tooling

**Jam Nut Sealing Caps**



IP68/69K

Part number	
UTS12DCG	



IP68/69K Metal terminal

Part number	
UTS12DCGR	

**Plug Sealing Cap**



IP68/69K

Part number	
UTS612DCG	

**Square Flange Sealing Cap**



IP68/69K Metal terminal

Part number	
UTS12DCGE	

**Plastic Protective Cap**



Part numbers	
Receptacle cap	Plug cap
85005587A	85005596

**Gasket**



Part numbers	
UTFD13B	

**Color Coding Rings**

G for Green 

Y for Yellow 

R for Red 

Part numbers	
Receptacles	Plugs
UTS712CCRR	UTS612CCRR
UTS712CCRY	UTS612CCRY
UTS712CCRG	UTS612CCRG

## 12E14/12D14 (Shell size 12, 14x#20)

### Contacts

#20	Contact type	Plating	Cable acceptance (AWG)	Wire stripping length
Hand solder	Loaded in the connector	Min 0.4μ gold over 0.8μ Ni	22 to 18	5 mm
PCB	Machined <sup>(1)</sup>	Min 0.4μ gold over 0.8μ Ni	-	-

(1): For dimensions see page 169

Electrical Characteristics
<p><b>UL</b> 4.5A 250V UL94 HB</p> <p><b>CSA</b> 4.5A 250V UL94 HB</p> <p><b>IEC</b> 5A 32V 1.5kV 3</p>

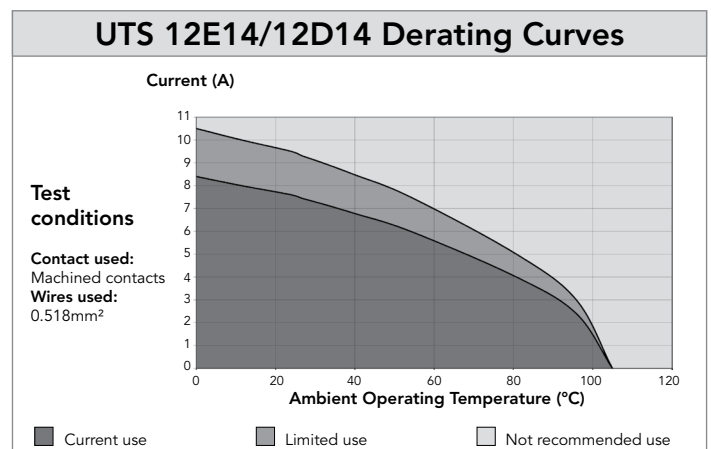

### 14E15/14D15 (Shell size 14, 14x#20, 1x#16)

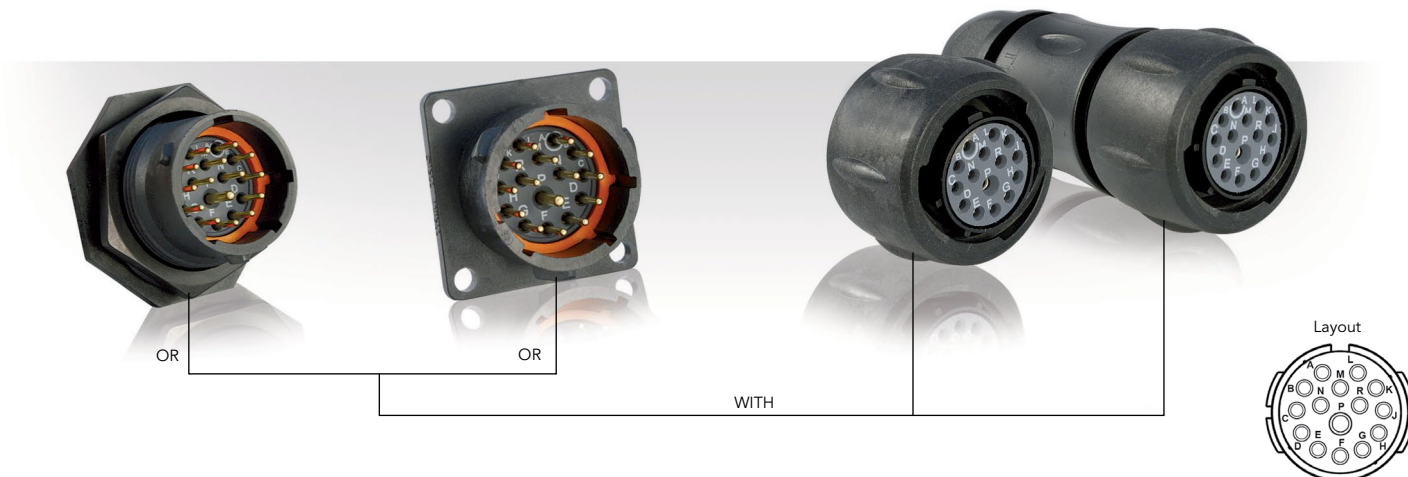

### Connector Part Numbers

Contact type	Connector type	Backshell	Part number	
			Male insert	Female insert
Hand solder electrical contacts loaded see page 135	Square flange receptacle	Without (Fig. 6)	<b>UTS014E15P</b>	<b>UTS014E15S</b>
	Plug	Without (Fig. 1)	<b>UTS614E15P</b>	<b>UTS614E15S</b>
		Cable gland (Fig. 2)	<b>UTS6JC14E15P</b>	<b>UTS6JC14E15S</b>
	Jam nut receptacle	Without (Fig. 3)	<b>UTS714E15P</b>	<b>UTS714E15S</b>
PCB contacts loaded see page 135	Square flange receptacle	Without (Fig. 7)	<b>UTS014D15P</b>	<b>UTS014D15S</b>
	Jam nut receptacle with stand off and with hold down clips	Without (Fig. 4)	<b>UTS714D15P32</b>	<b>UTS714D15S32</b>
	Jam nut receptacle with stand off and without hold down clip	Without (Fig. 5)	<b>UTS714D15P</b>	<b>UTS714D15S</b>

Possibilities of discrimination/keying methods see page 208

Sealed unmatod

### Overmoulded Cable Assembly Part Numbers

Overmoulding type	Connector type	Wire size (mm <sup>2</sup> )	Harmonized cable part number <sup>(1)</sup>	Part number (length: 1m.)*	
				Male plug	Female plug
Straight ending	Plug	1.5	H05 VV - F 15x1.5	<b>HAUTS0V14E15PST100</b>	<b>HAUTS0V14E15SST100</b>
Right angle ending	Plug	1.5	H05 VV - F 15x1.5	<b>HAUTS0V14E15PRA100</b>	<b>HAUTS0V14E15SRA100</b>

(1) Other cable available on demand

\* Other lengths available on demand

14E15/14D15 (Shell size 14, 14x#20, 1x#16)

Dimensions

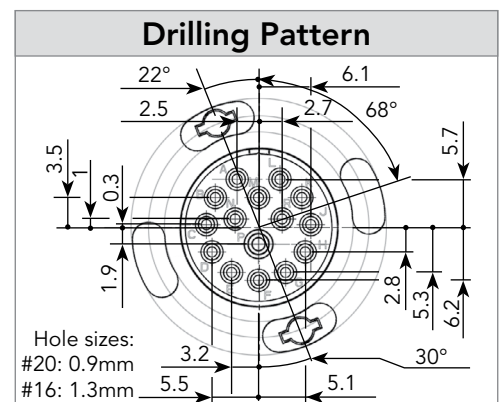
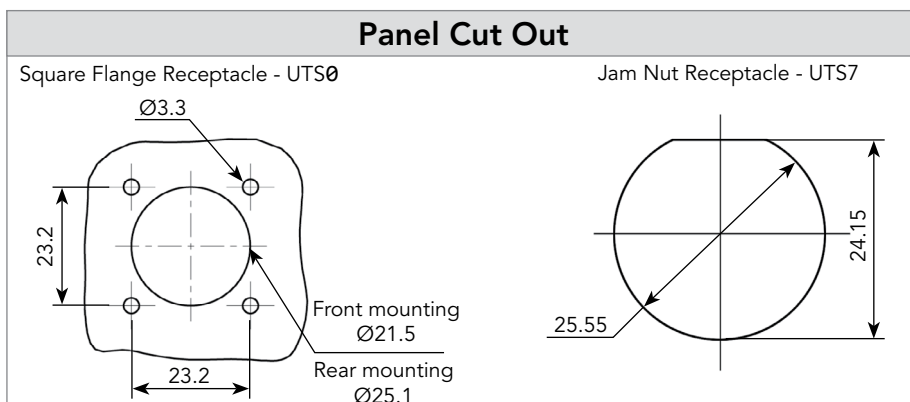
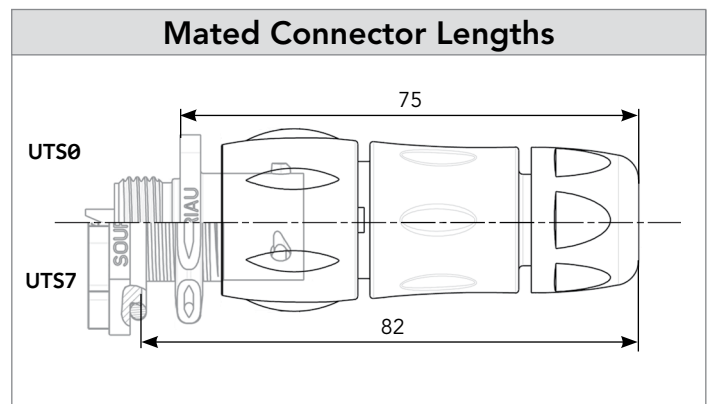
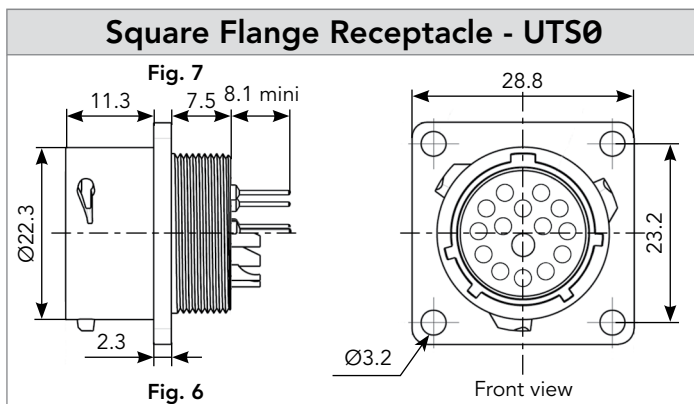
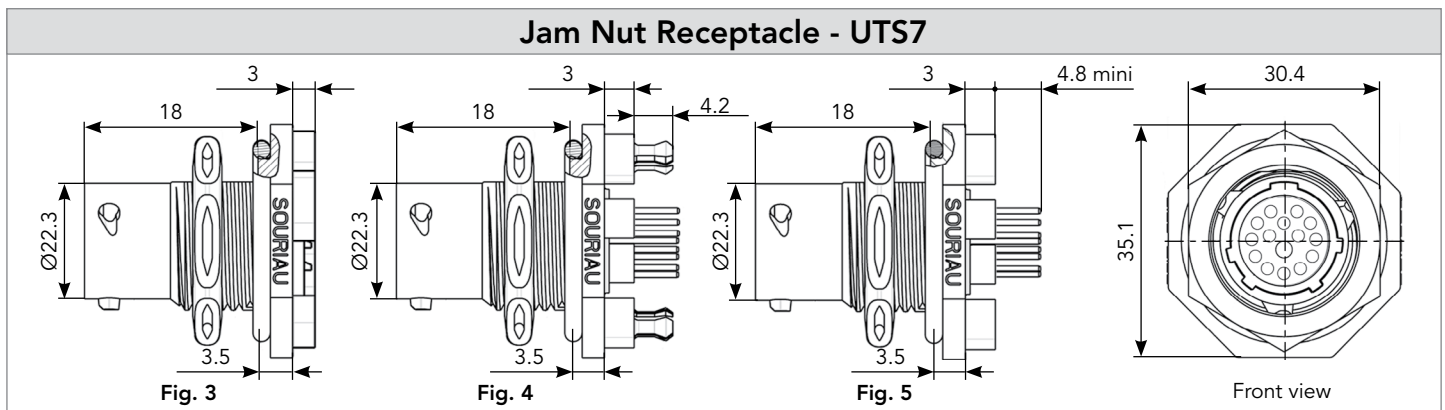
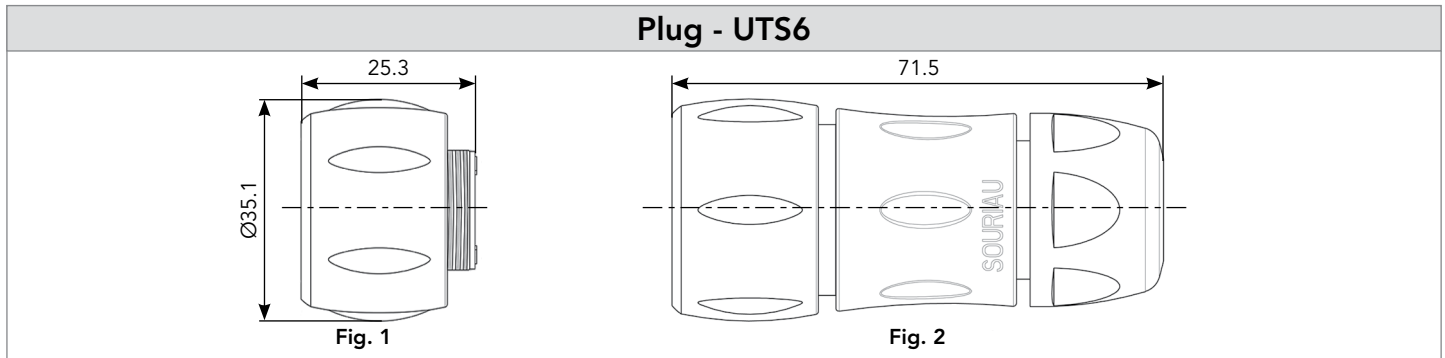

Note: Overmoulded cable assembly dimensions available page 179.

Note: all dimensions are in mm

14E15/14D15 (Shell size 14, 14x#20, 1x#16)

Accessories and Tooling

**Jam Nut Sealing Caps**



IP68/69K

Part number
UTS14DCG



IP68/69K Metal terminal

Part number
UTS14DCGR

**Plug Sealing Cap**



IP68/69K

Part number
UTS614DCG

**Square Flange Sealing Cap**



IP68/69K Metal terminal

Part number
UTS14DCGE

**Plastic Protective Cap**



Part numbers	
Receptacle cap	Plug cap
85005588A	85005597

**Gasket**



Part numbers
UTFD14B

**Color Coding Rings**

G for Green



Y for Yellow



R for Red



Part numbers	
Receptacles	Plugs
UTS714CCRR	UTS614CCRR
UTS714CCRY	UTS614CCRY
UTS714CCRG	UTS614CCRG

## 14E15/14D15 (Shell size 14, 14x#20, 1x#16)

### Contacts

#16	Contact type	Plating	Cable acceptance (AWG)	Wire stripping length
Handsold	Loaded in the connector	Min 0.4μ gold over 0.8μ Ni	18 to 14	5.0 mm
PCB	Machined <sup>(1)</sup>	Min 0.4μ gold over 0.8μ Ni	-	-
#20	Contact type	Plating	Cable acceptance (AWG)	Wire stripping length
Handsold	Loaded in the connector	Min 0.4μ gold over 0.8μ Ni	22 to 18	3.8 mm
PCB	Machined <sup>(1)</sup>	Min 0.4μ gold over 0.8μ Ni	-	-

(1): For dimensions see page 169

Electrical Characteristics
<p><b>UL</b> 12A 600V UL94 HB</p> <p><b>CSA</b> 12A 600V UL94 HB</p> <p><b>IEC</b> 4A 50V 1.5kV 3</p>

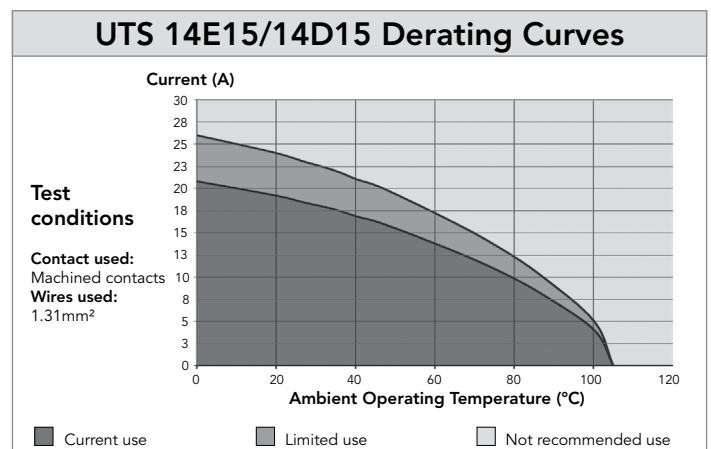

### 14E18/14D18 (Shell size 14, 18x#20)

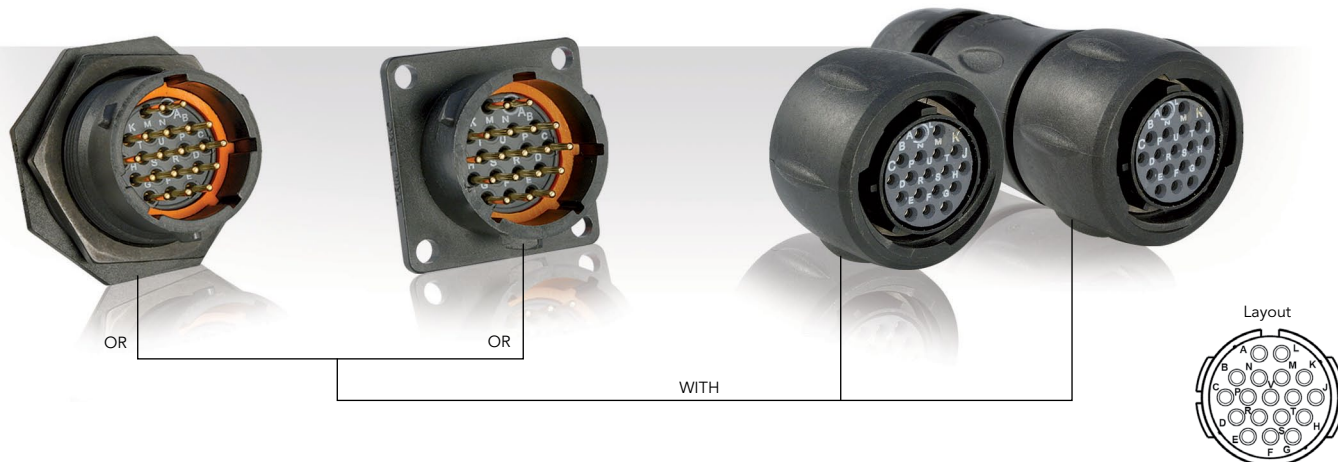

### Connector Part Numbers

Contact type	Connector type	Backshell	Part number	
			Male insert	Female insert
Hand solder electrical contacts loaded see page 139	Square flange receptacle	Without (Fig. 6)	<b>UTS014E18P</b>	<b>UTS014E18S</b>
	Plug	Without (Fig. 1)	<b>UTS614E18P</b>	<b>UTS614E18S</b>
		Cable gland (Fig. 2)	<b>UTS6JC14E18P</b>	<b>UTS6JC14E18S</b>
	Jam nut receptacle	Without (Fig. 3)	<b>UTS714E18P</b>	<b>UTS714E18S</b>
PCB contacts loaded see page 139	Square flange receptacle	Without (Fig. 7)	<b>UTS014D18P</b>	<b>UTS014D18S</b>
	Jam nut receptacle with stand off and with hold down clips	Without (Fig. 4)	<b>UTS714D18P32</b>	<b>UTS714D18S32</b>
	Jam nut receptacle with stand off and without hold down clip	Without (Fig. 5)	<b>UTS714D18P</b>	<b>UTS714D18S</b>

Possibilities of discrimination/keying methods see page 208

Sealed unmatd

### Overmoulded Cable Assembly Part Numbers

Overmoulding type	Connector type	Wire size (mm <sup>2</sup> )	Harmonized cable part number <sup>(1)</sup>	Part number (length: 1m.)*	
				Male plug	Female plug
Straight ending	Plug	0.5	H05 VV - F 18x0.5	<b>HAUTS0V14E18PST100</b>	<b>HAUTS0V14E18SST100</b>
Right angle ending	Plug	0.5	H05 VV - F 18x0.5	<b>HAUTS0V14E18PRA100</b>	<b>HAUTS0V14E18SRA100</b>

(1) Other cable available on demand

\* Other lengths available on demand



14E18/14D18 (Shell size 14, 18x#20)

Dimensions

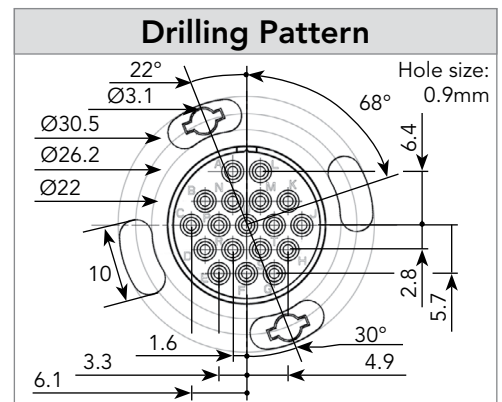
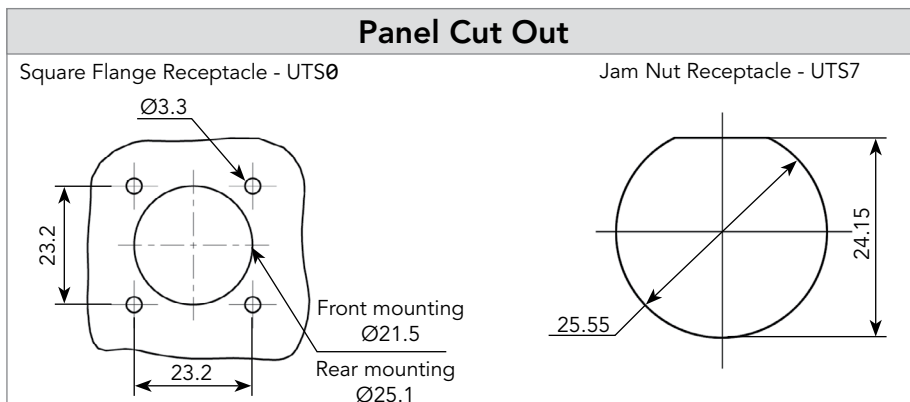
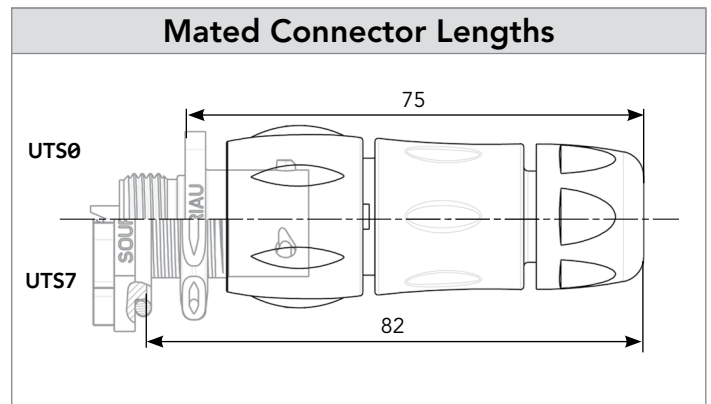
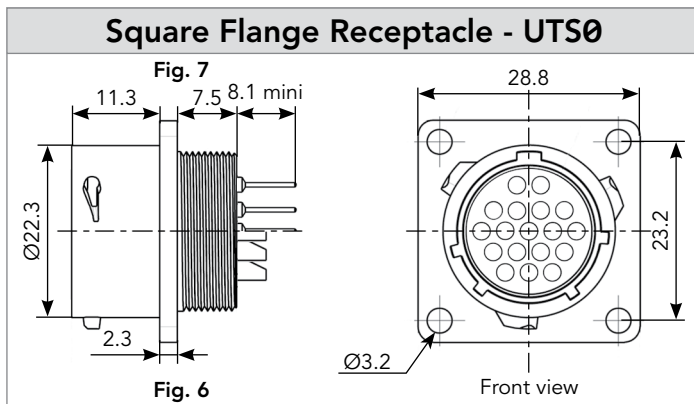
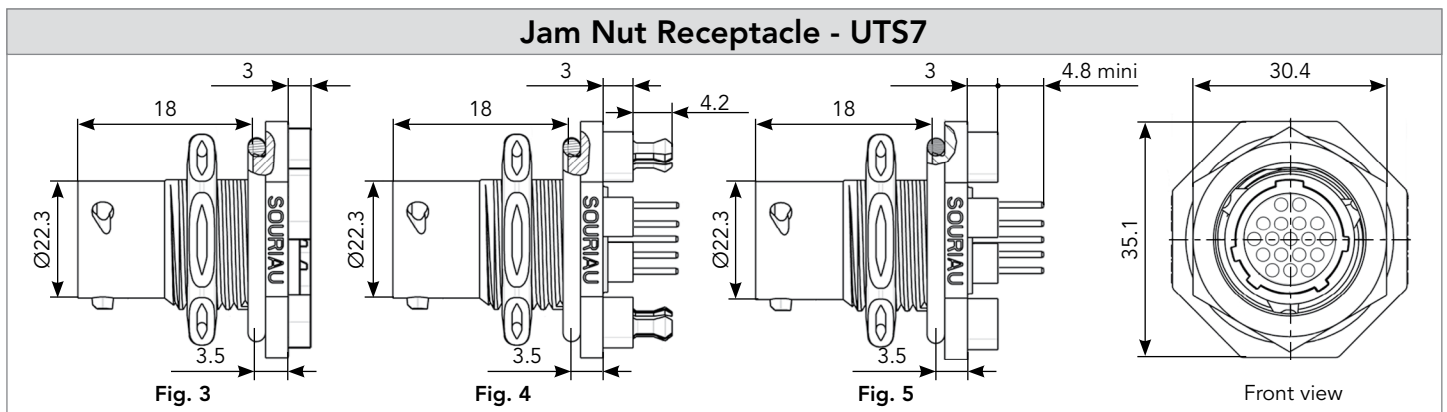
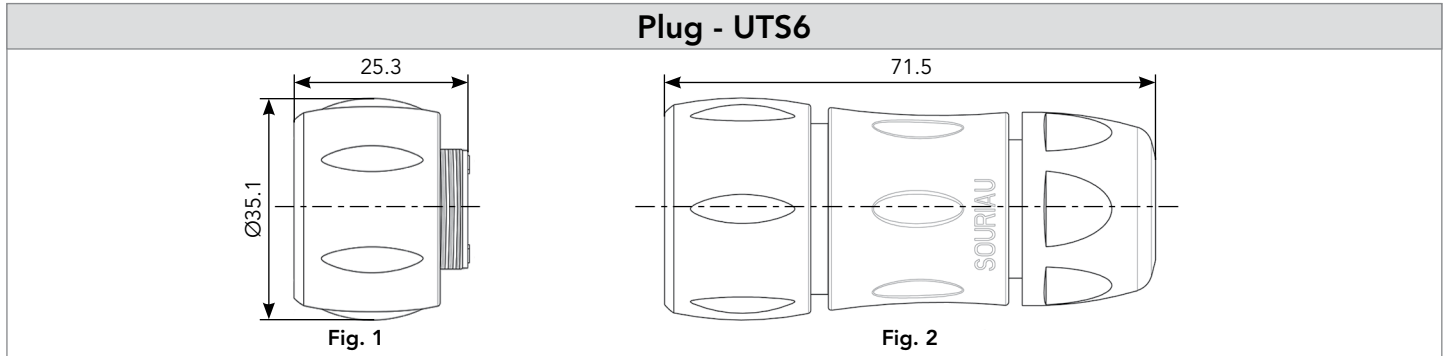

Note: Overmoulded cable assembly dimensions available page 179.

Note: all dimensions are in mm

14E18/14D18 (Shell size 14, 18x#20)

Accessories and Tooling

**Jam Nut Sealing Caps**



IP68/69K

Part number
UTS14DCG



IP68/69K Metal terminal

Part number
UTS14DCGR

**Plug Sealing Cap**



IP68/69K

Part number
UTS614DCG

**Square Flange Sealing Cap**



IP68/69K Metal terminal

Part number
UTS14DCGE

**Plastic Protective Cap**



Part numbers	
Receptacle cap	Plug cap
85005588A	85005597

**Gasket**



Part numbers
UTFD14B

**Color Coding Rings**

G for Green 

Y for Yellow 

R for Red 

Part numbers	
Receptacles	Plugs
UTS714CCRR	UTS614CCRR
UTS714CCRY	UTS614CCRY
UTS714CCRG	UTS614CCRG

# 14E18/14D18 (Shell size 14, 18x#20)

## Contacts

#20	Contact type	Plating	Cable acceptance (AWG)	Wire stripping length
Hand solder	Loaded in the connector	Min 0.4μ gold over 0.8μ Ni	22 to 18	5 mm
PCB	Machined <sup>(1)</sup>	Min 0.4μ gold over 0.8μ Ni	-	-

(1): For dimensions see page 169

### Electrical Characteristics

**UL**  
 4A 250V UL94 HB  
  
**CSA**  
 4A 250V UL94 HB  
  
**IEC**  
 5A 50V 1.5kV 3

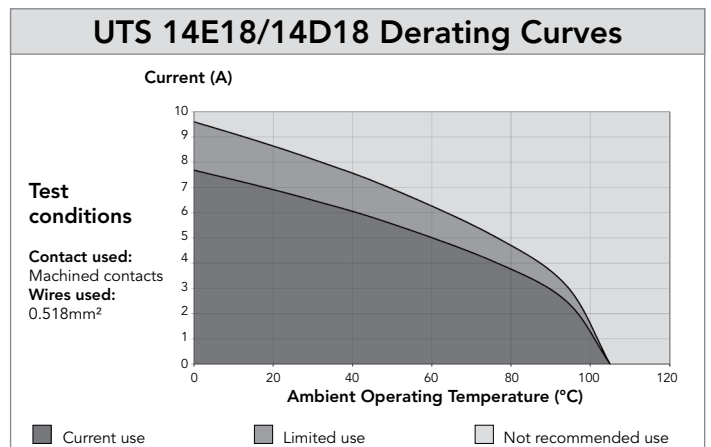

## 1419 - 14E19/14D19 (Shell size 14, 19x#20)

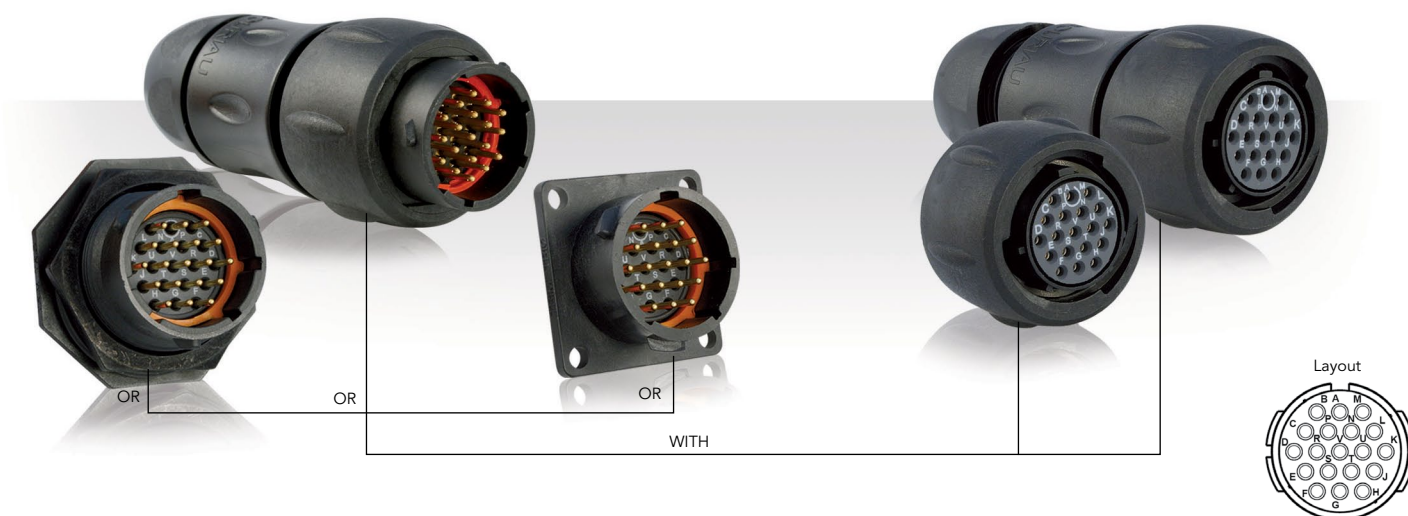

### Connector Part Numbers

Contact type	Connector type	Backshell	Part number	
			Male insert	Female insert
Crimp contacts supplied separately see page 143	Free hanging receptacle	Cable gland (Fig. 1)	<b>UTS1JC1419P</b>	<b>UTS1JC1419S</b>
	Plug	Without (Fig. 2)	<b>UTS61419P</b>	<b>UTS61419S</b>
	Plug	Cable gland (Fig. 3)	<b>UTS6JC1419P</b>	<b>UTS6JC1419S</b>
	Jam nut receptacle	Without (Fig. 4)	<b>UTS71419P</b>	<b>UTS71419S</b>
PCB contacts supplied separately see page 143	Jam nut receptacle	Without (Fig. 4)	<b>UTS71419P</b>	<b>UTS71419S</b>
Hand solder electrical contacts loaded see page 143	Square flange receptacle	Without (Fig. 8)	<b>UTS014E19P</b>	<b>UTS014E19S</b>
	Plug	Without (Fig. 2)	<b>UTS614E19P</b>	<b>UTS614E19S</b>
		Cable gland (Fig. 3)	<b>UTS6JC14E19P</b>	<b>UTS6JC14E19S</b>
	Jam nut receptacle	Without (Fig. 5)	<b>UTS714E19P</b>	<b>UTS714E19S</b>
PCB contacts loaded see page 143	Square flange receptacle	Without (Fig. 9)	<b>UTS014D19P</b>	<b>UTS014D19S</b>
	Jam nut receptacle with stand off and with hold down clips	Without (Fig. 6)	<b>UTS714D19P32</b>	<b>UTS714D19S32</b>
	Jam nut receptacle with stand off and without hold down clip	Without (Fig. 7)	<b>UTS714D19P</b>	<b>UTS714D19S</b>

Possibilities of discrimination/keying methods see page 208

Sealed unmetad

### Overmoulded Cable Assembly Part Numbers

Overmoulding type	Connector type	Wire size (mm <sup>2</sup> )	Harmonized cable part number <sup>(1)</sup>	Part number (length: 1m.)*	
				Male plug	Female plug
Straight ending	Plug	0.5	H05 VV - F 19x0.5	<b>HAUTS0V1419PST100</b>	<b>HAUTS0V1419SST100</b>
				<b>HAUTS0V14E19PST100</b>	<b>HAUTS0V14E19SST100</b>
Right angle ending	Plug	0.5	H05 VV - F 19x0.5	<b>HAUTS0V1419PRA100</b>	<b>HAUTS0V1419SRA100</b>
				<b>HAUTS0V14E19PRA100</b>	<b>HAUTS0V14E19SRA100</b>

(1) Other cable available on demand

\* Other lengths available on demand

1419 - 14E19/14D19 (Shell size 14, 19x#20)

Dimensions

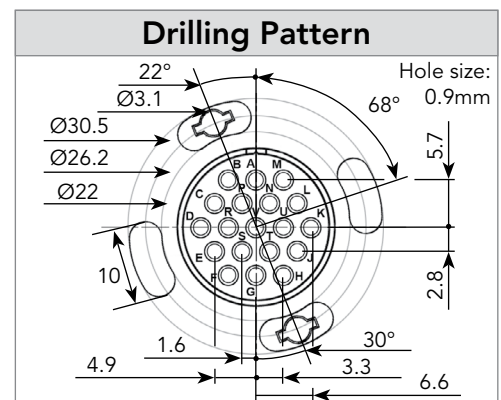
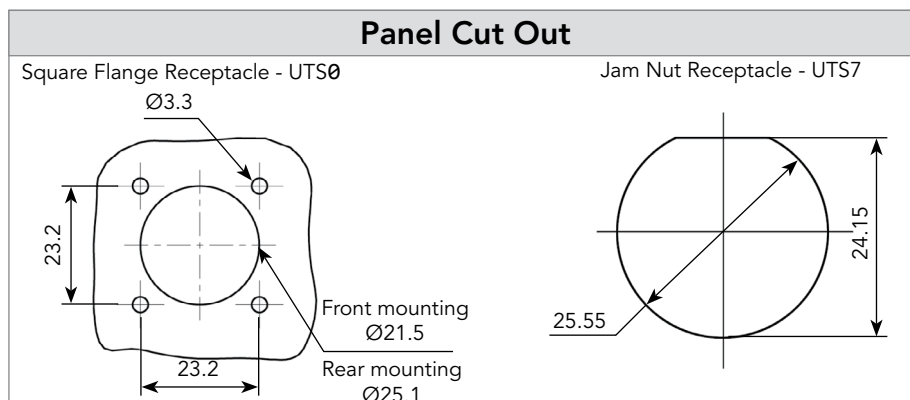
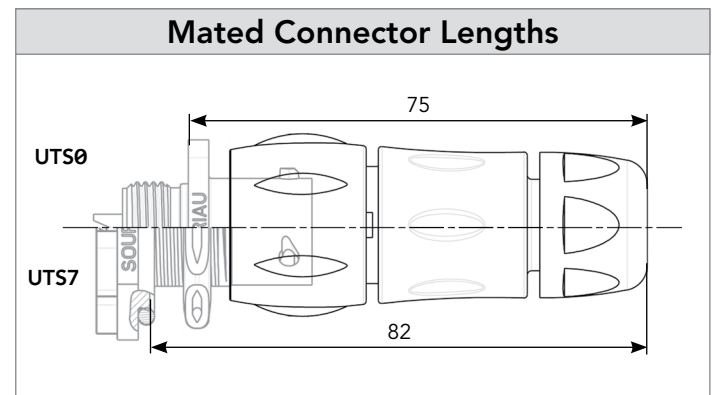
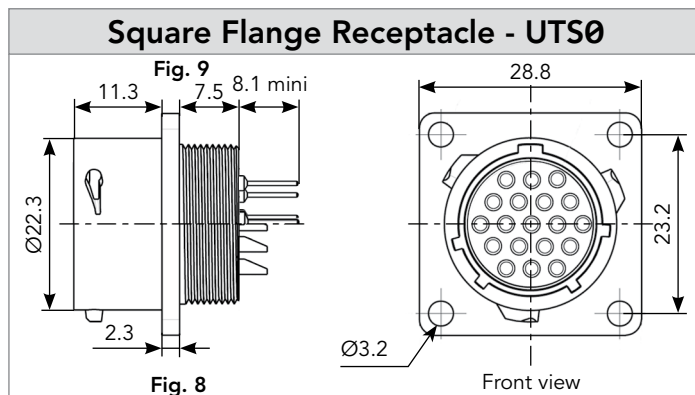
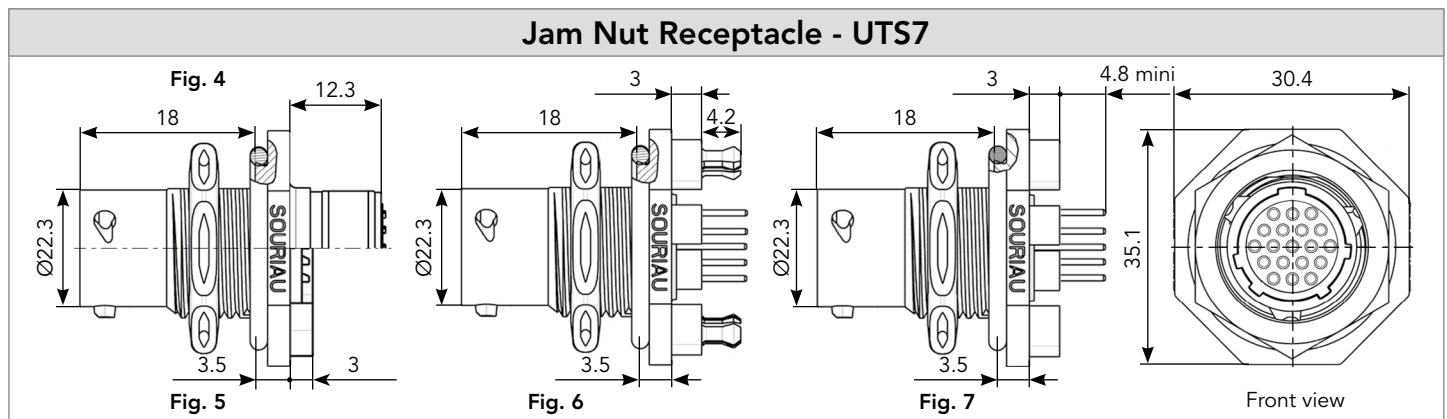
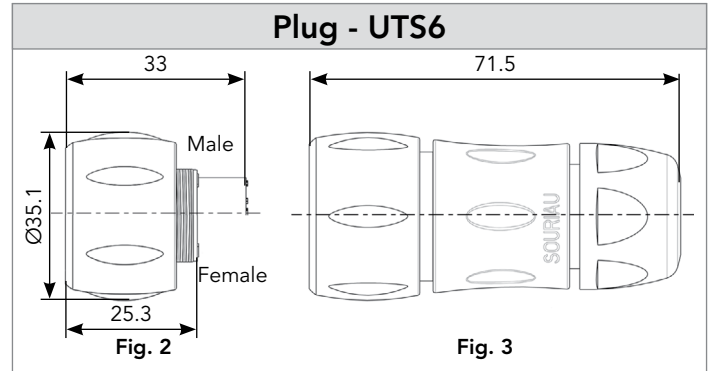
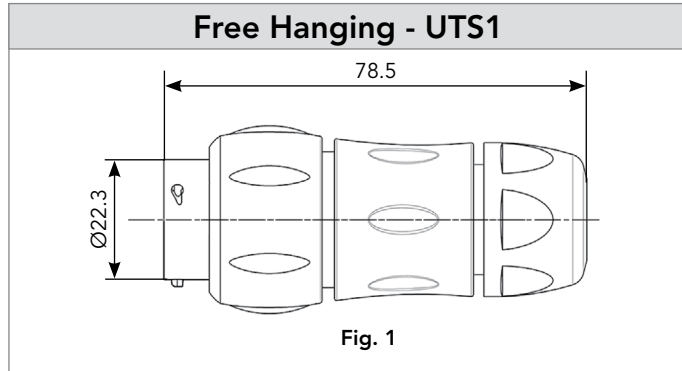

Note: Overmoulded cable assembly dimensions available page 179.

Note: all dimensions are in mm

# 1419 - 14E19/14D19 (Shell size 14, 19x#20)

## Accessories and Tooling

### Jam Nut Sealing Caps



IP68/69K

Part number
UTS14DCG



IP68/69K Metal terminal

Part number
UTS14DCGR

### Handle (without Head)



Part number
SHANDLES

### Tool Kit



Part number
TOOLKIT

### Plug Sealing Cap



IP68/69K

Part number
UTS614DCG

### Square Flange Sealing Cap



IP68/69K Metal terminal

Part number
UTS14DCGE

### Crimp Tooling (without Shandles)



Contacts	Contact size	Part number of head
RM/RC 24W3K <sup>(1)</sup>	Standard contacts #20 Ø 1mm	S20RCM*
RM/RC 20W3K <sup>(1)</sup>		S20RCM*
RM/RC 18W3K <sup>(1)</sup>		S20RCM*
SM/SC 24WL3S		S20SCM20*
SM/SC 20WL3S		S20SCM20*

(1): Example of plating, for other plating see page 164  
\*: Heads to be used with handle PN: SHANDLES

### Plastic Protective Cap



Part numbers	
Receptacle cap	Plug cap
85005588A	85005597

### Gasket



Part numbers
UTFD14B

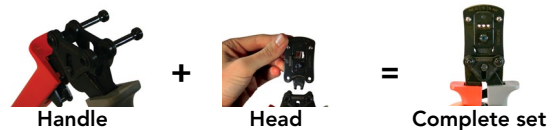

### Color Coding Rings

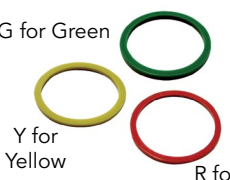

Part numbers	
Receptacles	Plugs
UTS714CCRR	UTS614CCRR
UTS714CCRY	UTS614CCRY
UTS714CCRG	UTS614CCRG

G for Green  
Y for Yellow  
R for Red

### Extraction Tool #20



Part number
RX20D44

1419 - 14E19/14D19 (Shell size 14, 19x#20)

Contacts

#20	Contact type	Wire size		Part number		Max wire Ø	Max insulator Ø	Wire striping length
		AWG	mm²	Male	Female			
Crimp	Machined	26-24	0.13-0.25	RM24W3K <sup>(1)</sup>	RC24W3K <sup>(1)</sup>	0.80	1.60	4.80
		22-20	0.32-0.52	RM20W3K <sup>(1)</sup>	RC20W3K <sup>(1)</sup>	1.15	1.60	4.80
		20-18	0.50-0.93	RM18W3K <sup>(1)</sup>	RC18W3K <sup>(1)</sup>	1.30	2.10	4.80
	Stamped & Formed reeled contacts See note (2) for loose piece	26-24	0.13-0.25	SM24W3TK6 <sup>(2)</sup>	SC24W3TK6 <sup>(2)</sup>	-	0.90-1.60	4.00
		26-24	0.13-0.25	SM24W3S26 <sup>(2)</sup>	SC24W3S25 <sup>(2)</sup>	-	0.90-1.60	4.00
		22-20	0.32-0.52	SM20W3TK6 <sup>(2)</sup>	SC20W3TK6 <sup>(2)</sup>	-	1.20-2.10	4.00
		22-20	0.32-0.52	SM20W3S26 <sup>(2)</sup>	SC20W3S25 <sup>(2)</sup>	-	1.20-2.10	4.00
PCB	Machined <sup>(3)</sup>	-	-	RMW5016K	RCW5016K	-	-	-
Hand-solder	Loaded in the connector	22-18	-	-	-	-	-	3.80

(1): Example of plating, for other plating see page 164 (2): Loose piece contact available if putting L. Example: SM20WL3TK6 (3): For dimensions see page 168 Note: all dimensions are in mm

Electrical Characteristics	
<p><b>UTS 1419</b> UL 5A 250V UL94 V-0</p> <p><b>CSA</b> 4A 250V UL94 V-0</p>	<p><b>UTS 14E19/14D19</b> UL 4A 250V UL94 HB</p> <p><b>CSA</b> 4A 250V UL94 HB</p> <p><b>IEC</b> 5A 32V 1.5kV 3</p>

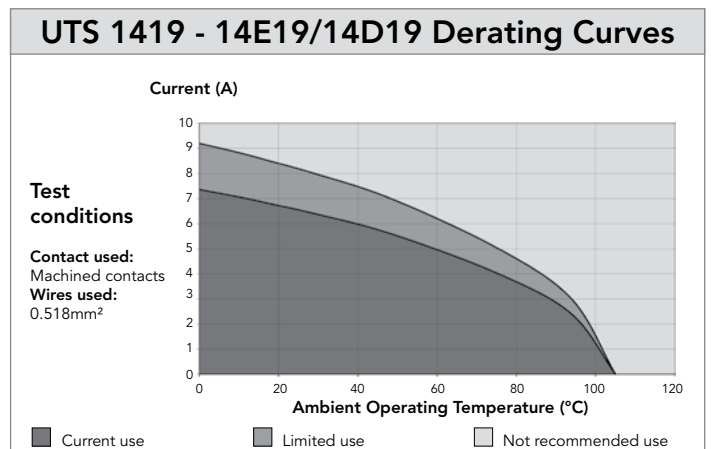

**1823** (Shell size 18, 23x#16)

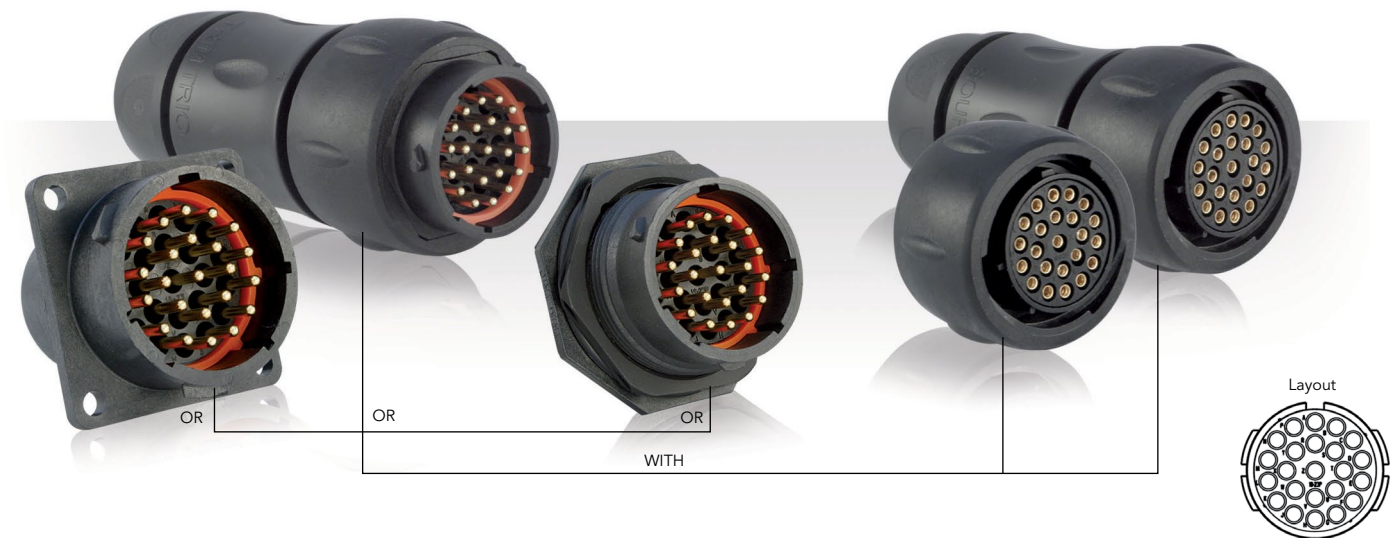

**Connector Part Numbers**

Contact type	Connector type	Backshell	Part number	
			Male insert	Female insert
Crimp contacts supplied separately see page 147	Square flange receptacle	Without (Fig. 1)	<b>UTS01823P</b>	<b>UTS01823S</b>
	Free hanging receptacle	Cable gland (Fig. 2)	<b>UTS1JC1823P</b>	<b>UTS1JC1823S</b>
	Plug	Without (Fig. 3)	<b>UTS61823P</b>	<b>UTS61823S</b>
	Plug	Cable gland (Fig. 4)	<b>UTS6JC1823P</b>	<b>UTS6JC1823S</b>
	Jam nut receptacle	Without (Fig. 5)	<b>UTS71823P</b>	<b>UTS71823S</b>
PCB contacts supplied separately see page 147	Square flange receptacle	Without (Fig. 1)	<b>UTS01823P</b>	<b>UTS01823S</b>
	Jam nut receptacle	Without (Fig. 5)	<b>UTS71823P</b>	<b>UTS71823S</b>

Possibilities of discrimination/keying methods see page 208

**Overmoulded Cable Assembly Part Numbers**

Overmoulding type	Connector type	Wire size (mm <sup>2</sup> )	Harmonized cable part number <sup>(1)</sup>	Part number (length: 1m.)*	
				Male plug	Female plug
Straight ending	Plug	1.5	H05 VV - F 23x1.5	<b>HAUTS0V1823PST100</b>	<b>HAUTS0V1823SST100</b>
Right angle ending	Plug	1.5	H05 VV - F 23x1.5	<b>HAUTS0V1823PRA100</b>	<b>HAUTS0V1823SRA100</b>

(1) Other cable available on demand

\* Other lengths available on demand



1823 (Shell size 18, 23x#16)

Dimensions

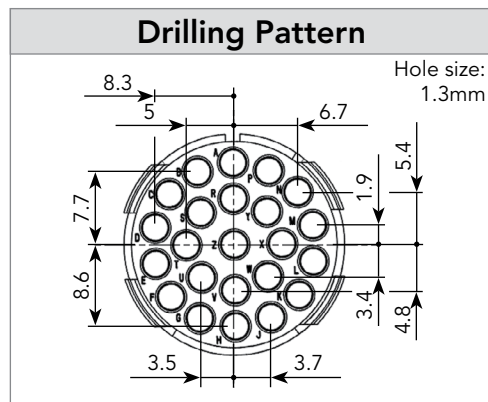
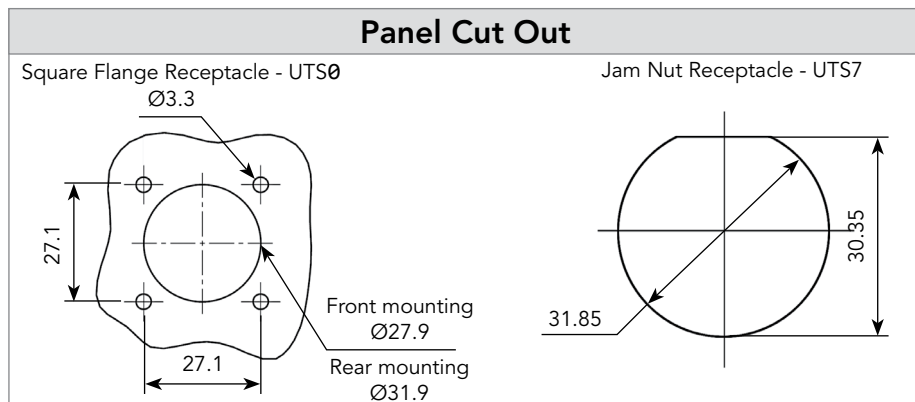
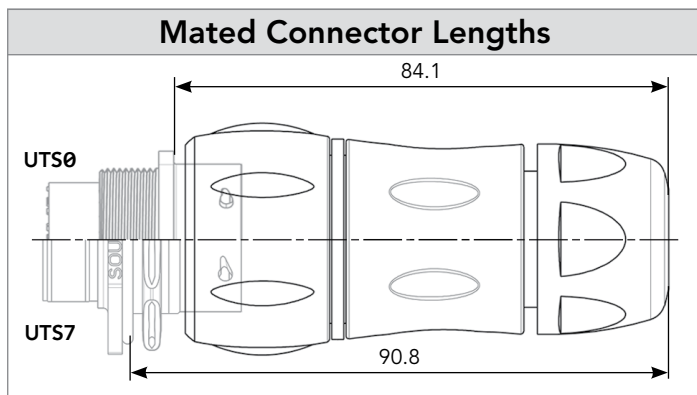
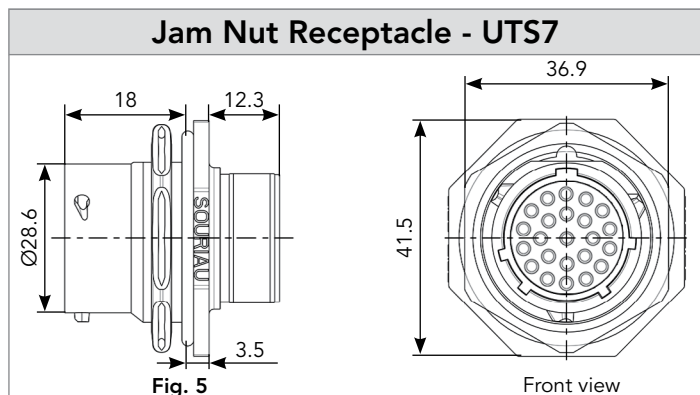
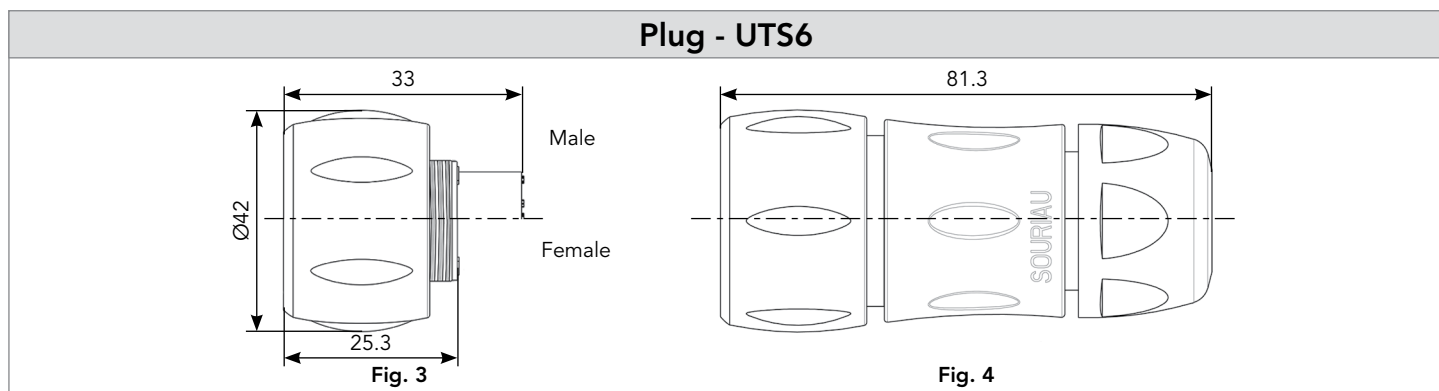
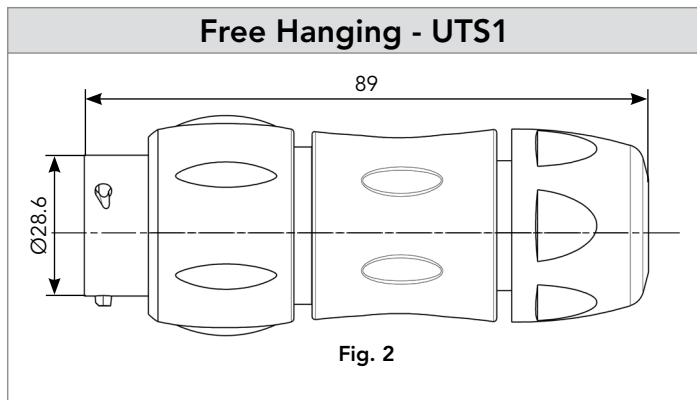
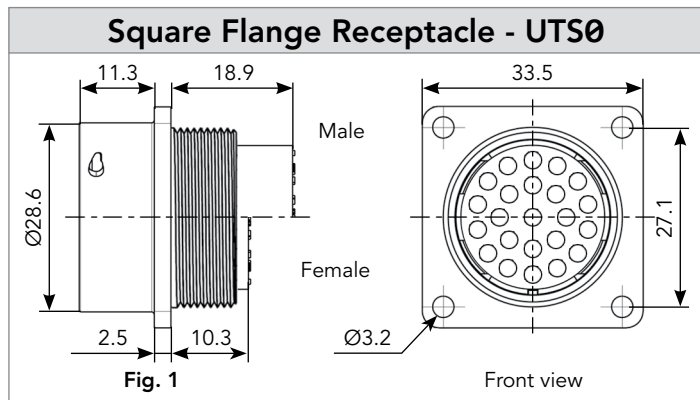

Note: Overmoulded cable assembly dimensions available page 179.

Note: all dimensions are in mm

# 1823 (Shell size 18, 23x#16)

## Accessories and Tooling

### Jam Nut Sealing Caps



IP68/69K

Part number
UTS18DCG



IP68/69K Metal terminal

Part number
UTS18DCGR

### Handle (without Head)



Part number
SHANDLES

### Tool Kit



Part number
TOOLKIT

### Plug Sealing Cap



IP68/69K

Part number
UTS618DCG

### Square Flange Sealing Cap



IP68/69K Metal terminal

Part number
UTS18DCGE

### Crimp Tooling (without Shandles)



Contacts	Contact size	Part number of head	
RM/RC 28M1K <sup>(1)</sup>	Standard contacts #16 Ø 1.6mm	S16RCM20*	
RM/RC 24M9K <sup>(1)</sup>		S16RCM20*	
RM/RC 20M13K <sup>(1)</sup>		S16RCM20*	
RM/RC 20M12K <sup>(1)</sup>		S16RCM20*	
RM/RC 16M23K <sup>(1)</sup>		S16RCM16*	
RM/RC 14M30K <sup>(1)</sup>		S16RCM14*	
SM/SC 24ML1TK6 <sup>(1)</sup>		S16SCM20*	
SM/SC 20ML1TK6 <sup>(1)</sup>		S16SCM20*	
SM/SC 16ML1TK6 <sup>(1)</sup>		S16SCML1*	
SM/SC 14ML1TK6 <sup>(1)</sup>		S16SCML1*	
SM/SC 16ML11TK6 <sup>(1)</sup>		S16SCML11*	
RMDXK10D28K		Coaxial contacts	M10S1J with die set & stop bushing see page 200 to 204
RCDXK1D28K			
RM/RC DX60xxD28K			
RM/RC DXK10D28 + york090			
RM/RC DX60xxD28			

(1): Example of plating, for other plating options see page 164  
\* Heads to be used with handle PN: SHANDLES

### Plastic Protective Cap



Part numbers	
Receptacle cap	Plug cap
85005590A	85005599

### Gasket



Part numbers
UTFD16B

### Color Coding Rings

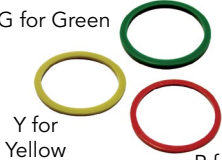

G for Green  
Y for Yellow  
R for Red

Part numbers	
Receptacles	Plugs
UTS718CCR	UTS618CCR
UTS718CCRY	UTS618CCRY
UTS718CCRG	UTS618CCRG



1823 (Shell size 18, 23x#16)

Contacts

#16	Contact type	AWG	Part number		Max wire Ø	Max insulator Ø
			Male	Female		
Crimp	Machined	30-28	RM28M1K <sup>(1)</sup>	RC28M1K <sup>(1)</sup>	0.55	1.00
		26-24	RM24M9K <sup>(1)</sup>	RC24M9K <sup>(1)</sup>	0.80	1.60
		22-20	RM20M13K <sup>(1)</sup>	RC20M13K <sup>(1)</sup>	1.15	1.80
		22-20	RM20M12K <sup>(1)</sup>	RC20M12K <sup>(1)</sup>	1.15	2.20
		20-16	RM16M23K <sup>(1)</sup>	RC16M23K <sup>(1)</sup>	1.80	3.20
		16-14	RM14M30K <sup>(1)</sup>	RC14M30K <sup>(1)</sup>	2.30	3.20
	Stamped & Formed reeled contacts See note (2) for loose piece	26-24	SM24M1TK6 <sup>(1)(2)</sup>	SC24M1TK6 <sup>(1)(2)</sup>	-	0.90-1.60
		22-20	SM20M1TK6 <sup>(1)(2)</sup>	SC20M1TK6 <sup>(1)(2)</sup>	-	1.20-2.10
		18-16	SM16M1TK6 <sup>(1)(2)</sup>	SC16M1TK6 <sup>(1)(2)</sup>	-	3.20
		18-16	SM16M11TK6 <sup>(1)(2)</sup>	SC16M11TK6 <sup>(1)(2)</sup>	-	3.00
14		SM14M1TK6 <sup>(1)(2)</sup>	SC14M1TK6 <sup>(1)(2)</sup>	-	3.20	
PCB	Machined <sup>(3)</sup>	-	RM20M12E83K <sup>(1)</sup>	RC20M12E84K <sup>(1)</sup>	-	-
Coaxial	Cable Multipiece	see pages 167, 200 to 206	RMDXK10D28	RCDXK1D28	-	-
	Cable Monocrimp		RMDX60xxD28	RCDX60xxD28	-	-
	Twisted pair Multipiece		RMDXK10D28 + york090	RCDXK1D28 + york090	-	-
	Twisted pair Monocrimp		RMDX60xxD28	RCDX60xxD28	-	-
Fiber optic	POF contacts (Plastic Optical Fiber)	-	RMPOF1000	RCPOF1000B	-	-

(1): Example of plating, for other plating see page 164 (2): Loose piece contact available if putting L. Example: SM20ML1TK6 (3): For dimensions see page 168 Note: all dimensions are in mm

Electrical Characteristics
<p><b>UL</b> 10A 500V UL94 V-0</p> <p><b>CSA</b> 7A 500V UL94 V-0</p> <p><b>IEC</b> 9A 63V 1.5kV 3</p>

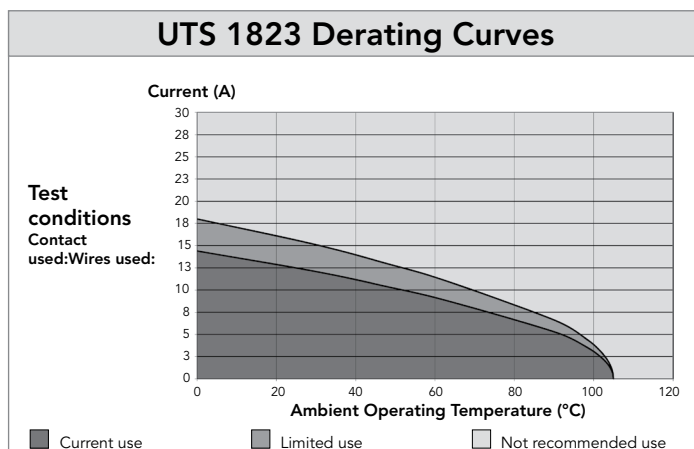

**1832 - 18E32** (Shell size 18, 32x#20)



**Connector Part Numbers**

Contact type	Connector type	Backshell	Part number	
			Male insert	Female insert
Crimp Contact supplied separately see page 151	Free hanging receptacle	Cable gland (Fig. 2)	<b>UTS1JC1832P</b>	<b>UTS1JC1832S</b>
	Plug	Without (Fig. 3)	<b>UTS61832P</b>	<b>UTS61832S</b>
	Plug	Cable gland (Fig. 4)	<b>UTS6JC1832P</b>	<b>UTS6JC1832S</b>
	Jam nut receptacle	Without (Fig. 5)	<b>UTS71832P</b>	<b>UTS71832S</b>
PCB contacts supplied separately see page 151	Jam nut receptacle	Without (Fig. 5)	<b>UTS71832P</b>	<b>UTS71832S</b>
Hand solder electrical contacts loaded see page 151	Square flange receptacle	Without (Fig. 1)	<b>UTS018E32P</b>	-

Possibilities of discrimination/keying methods see page 208

Sealed unmated

**Overmoulded Cable Assembly Part Numbers**

Overmoulding type	Connector type	Wire size (mm <sup>2</sup> )	Harmonized cable part number <sup>(1)</sup>	Part number (length: 1m.)*	
				Male plug	Female plug
Straight ending	Plug	0.5	H05 VV - F 32x0.5	<b>HAUTS0V1832PST100</b>	<b>HAUTS0V1832SST100</b>
Right angle ending	Plug	0.5	H05 VV - F 32x0.5	<b>HAUTS0V1832PRA100</b>	<b>HAUTS0V1832SRA100</b>

(1) Other cable available on demand

\* Other lengths available on demand

1832 - 18E32 (Shell size 18, 32x#20)

Dimensions

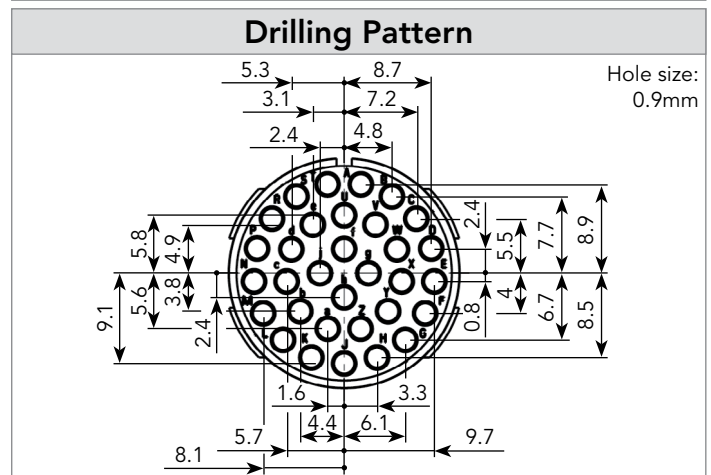
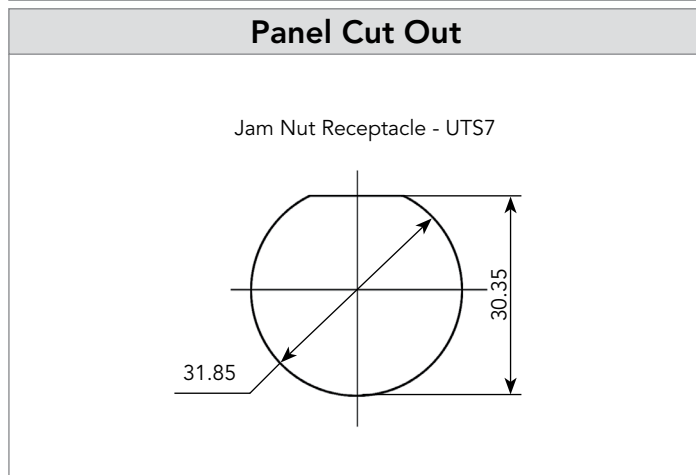
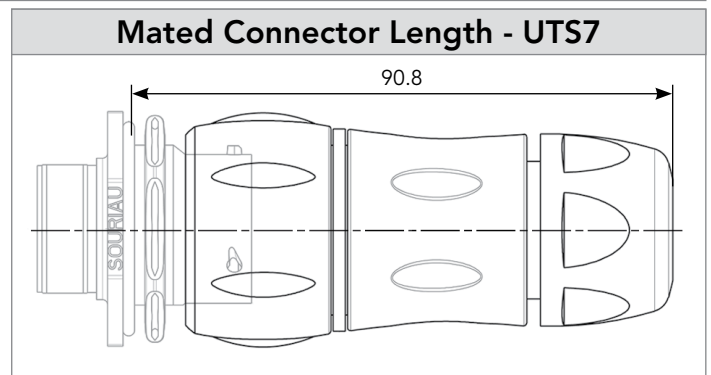
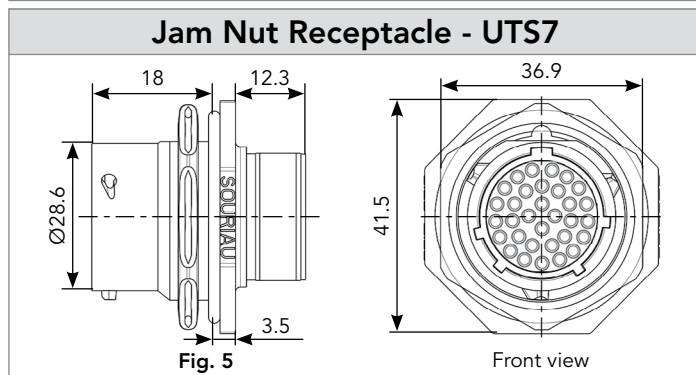
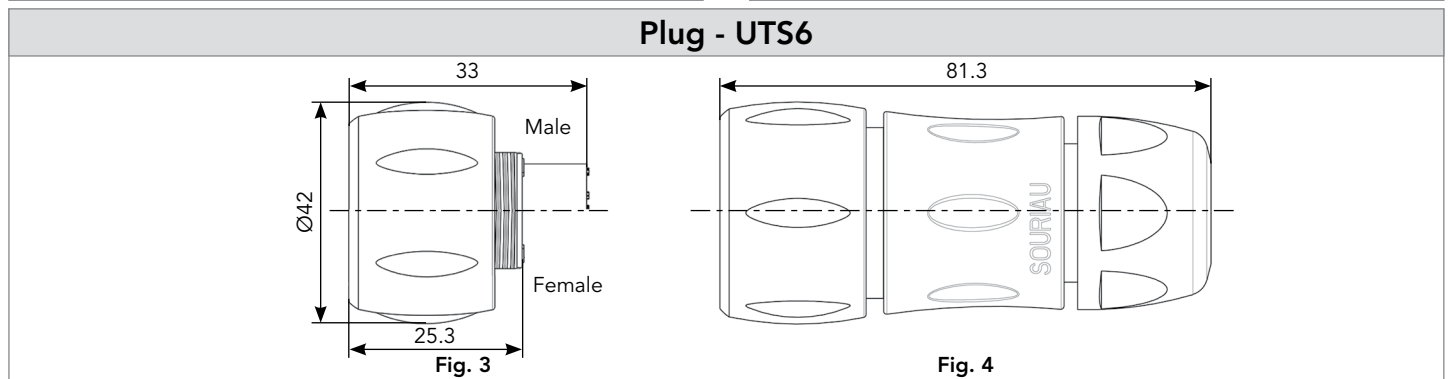
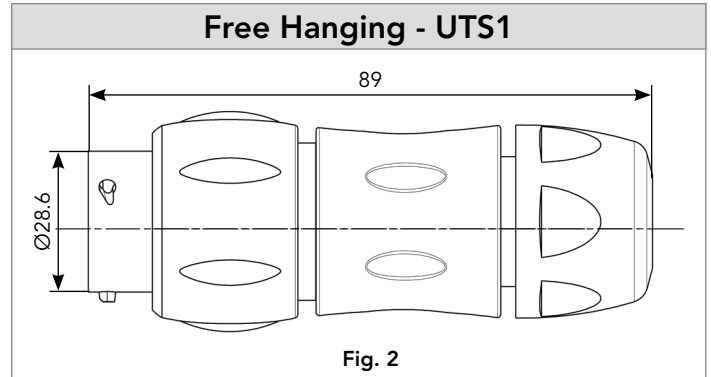
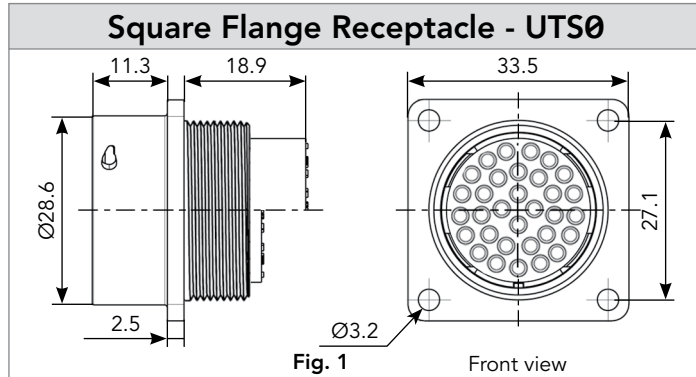

Note: Overmoulded cable assembly dimensions available page 179.

Note: all dimensions are in mm

1832 - 18E32 (Shell size 18, 32x#20)

Accessories and Tooling

### Jam Nut Sealing Caps



IP68/69K

Part number
UTS18DCG



IP68/69K Metal terminal

Part number
UTS18DCGR

### Handle (without Head)



Part number
SHANDLES

### Tool Kit



Part number
TOOLKIT

### Plug Sealing Cap



IP68/69K

Part number
UTS618DCG

### Square Flange Sealing Cap



IP68/69K Metal terminal

Part number
UTS18DCGE

### Crimp Tooling (without Shandles)



Contacts	Contact size	Part number of head
RM/RC 24W3K <sup>(1)</sup>	Standard contacts #20 Ø 1mm	S20RCM*
RM/RC 20W3K <sup>(1)</sup>		S20RCM*
RM/RC 18W3K <sup>(1)</sup>		S20RCM*
SM/SC 24WL3S		S20SCM20*
SM/SC 20WL3S		S20SCM20*

(1): Example of plating, for other plating see page 164  
\*: Heads to be used with handle PN: SHANDLES

### Plastic Protective Cap



Part numbers	
Receptacle cap	Plug cap
85005590A	85005599

### Gasket



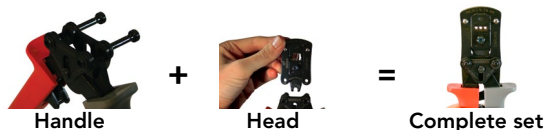

Part numbers
UTFD16B



### Color Coding Rings

G for Green 

Y for Yellow 

R for Red 

Part numbers	
Receptacles	Plugs
UTS718CCRR	UTS618CCRR
UTS718CCRY	UTS618CCRY
UTS718CCRG	UTS618CCRG

### Extraction Tool #20



Part number
RX20D44

1832 - 18E32 (Shell size 18, 32x#20)

Contacts

#20	Contact type	Wire size		Part number		Max wire Ø	Max insulator Ø	Wire stripping length
		AWG	mm <sup>2</sup>	Male	Female			
Crimp	Machined	26-24	0.13-0.25	RM24W3K <sup>(1)</sup>	RC24W3K <sup>(1)</sup>	0.80	1.60	4.80
		22-20	0.32-0.52	RM20W3K <sup>(1)</sup>	RC20W3K <sup>(1)</sup>	1.15	1.60	4.80
		20-18	0.50-0.93	RM18W3K <sup>(1)</sup>	RC18W3K <sup>(1)</sup>	1.30	2.10	4.80
	Stamped & Formed reeled contacts See note (2) for loose piece	26-24	0.13-0.25	SM24W3TK6 <sup>(2)</sup>	SC24W3TK6 <sup>(2)</sup>	-	0.90-1.60	4.00
		26-24	0.13-0.25	SM24W3S26 <sup>(2)</sup>	SC24W3S25 <sup>(2)</sup>	-	0.90-1.60	4.00
		22-20	0.32-0.52	SM20W3TK6 <sup>(2)</sup>	SC20W3TK6 <sup>(2)</sup>	-	1.20-2.10	4.00
		22-20	0.32-0.52	SM20W3S26 <sup>(2)</sup>	SC20W3S25 <sup>(2)</sup>	-	1.20-2.10	4.00
PCB	Machined <sup>(3)</sup>	-	-	RMW5016K	RCW5016K	-	-	-
Hand-solder	Loaded in the connector	18-22	-	-	-	-	-	3.80

(1): Example of plating, for other plating see page 164 (2): Loose piece contact available if putting L. Example: SM20WL3TK6 (3): For dimensions see page 168 Note: all dimensions are in mm

Electrical Characteristics
<p><b>UL</b> 5A 250V UL94 V-0</p> <p><b>CSA</b> 4A 250V UL94 V-0</p> <p><b>IEC</b> 4A 32V 1.5kV 3</p>

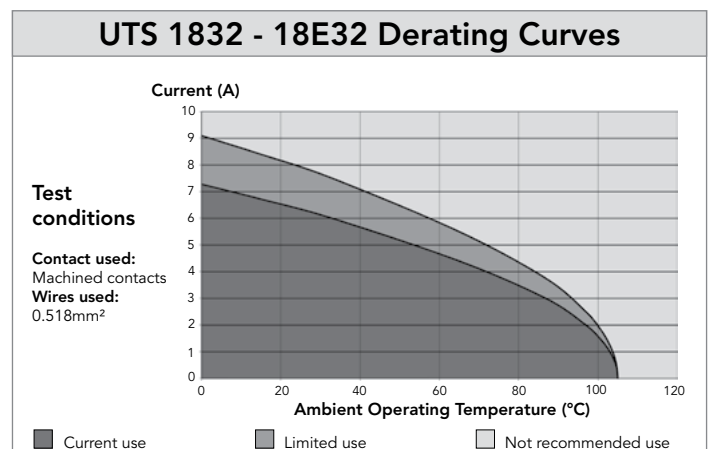

LC

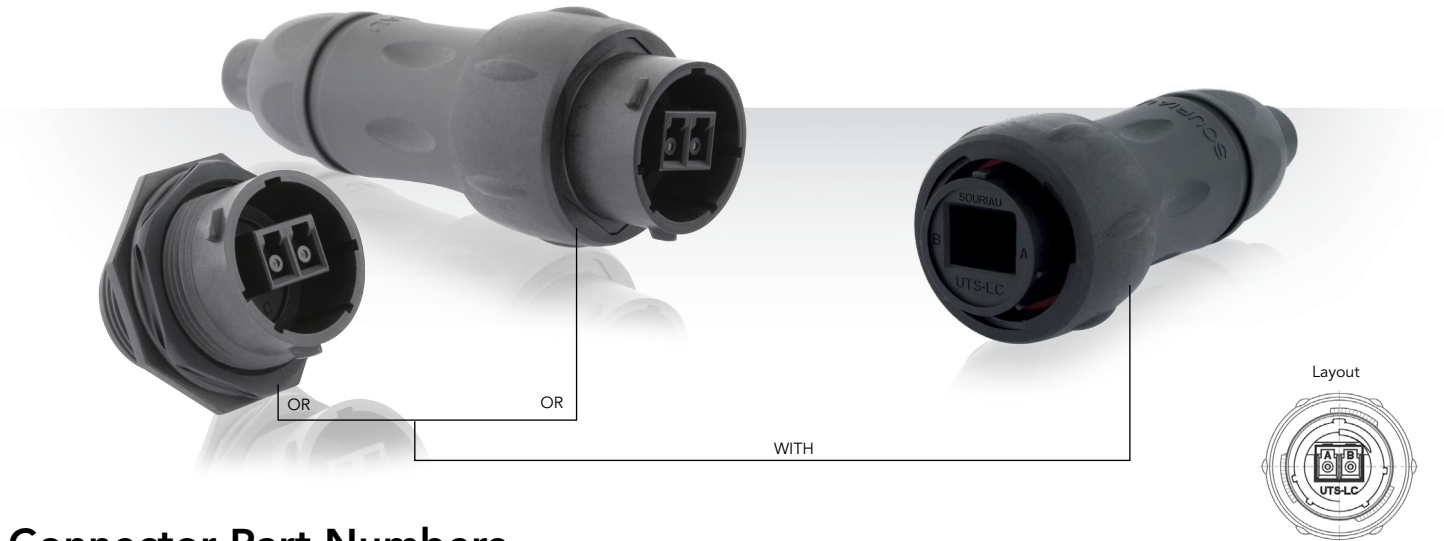

Connector Part Numbers

Connector type	Backshell	Part number	
		Male insert	Female insert
Free hanging receptacle	Cable gland	<b>UTS1JC18LCN</b>	-
Plug	Cable gland	-	<b>UTS6JC18LCN</b>
Jam nut receptacle	Without	<b>UTS718LCN</b>	-



# LC

## Dimensions

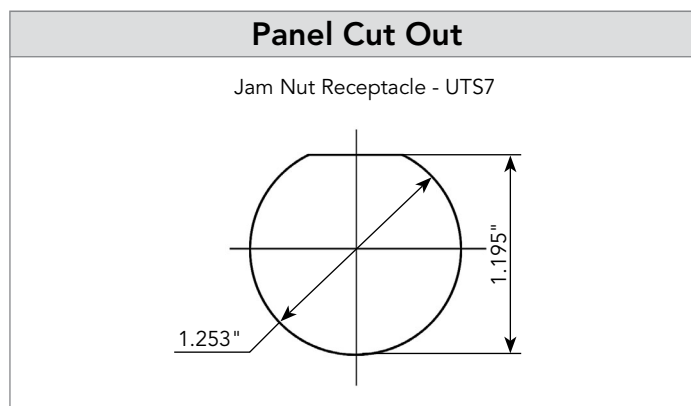
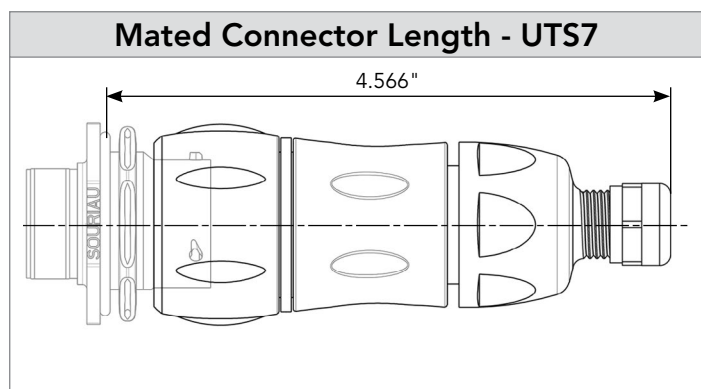
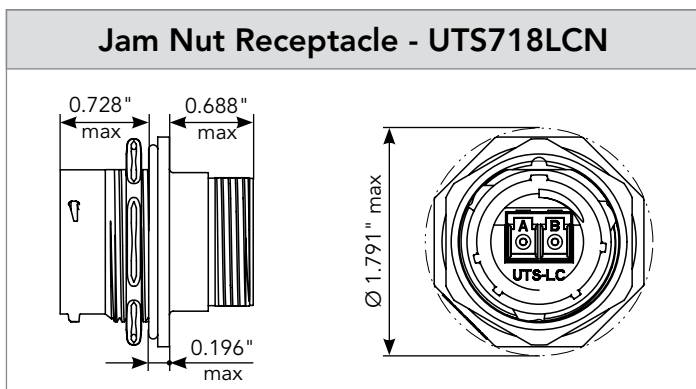
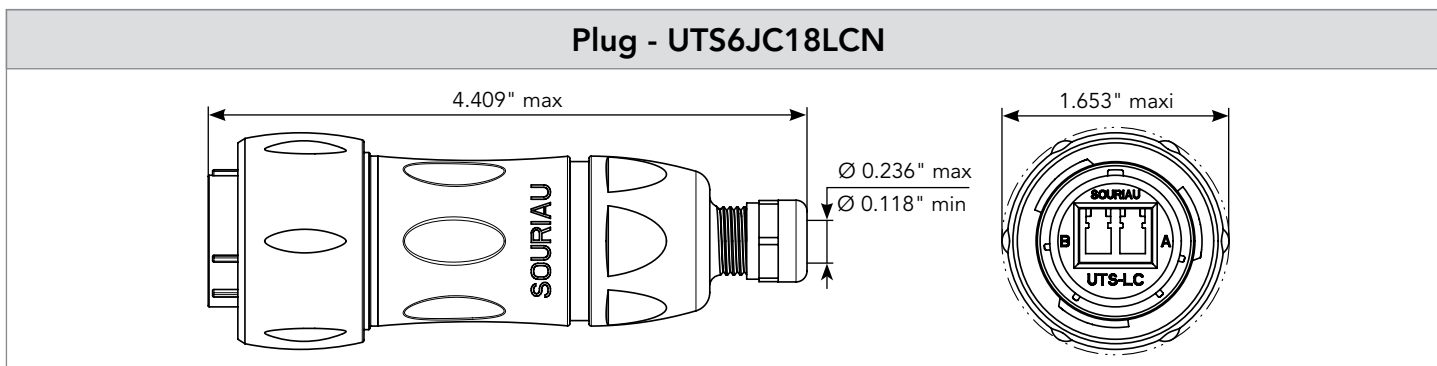
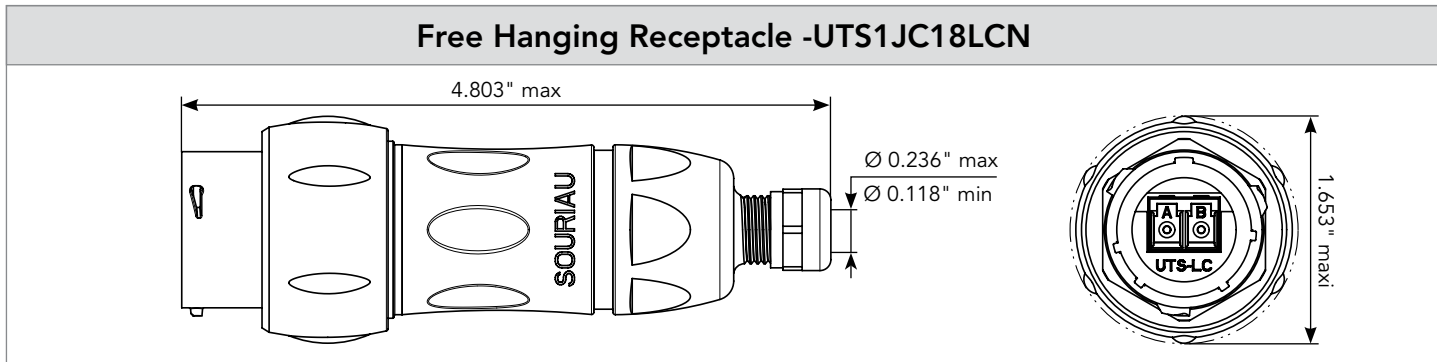

# LC

## Accessories

Sealing Caps					
<p>For UTS6JC18LCN</p>  <table border="1"><tr><td>Part number</td></tr><tr><td>UTS618DCG2</td></tr></table>	Part number	UTS618DCG2	<p>For UTS1JC18LCN &amp; UTS718LCN</p>  <table border="1"><tr><td>Part number</td></tr><tr><td>UTS18DCG2</td></tr></table>	Part number	UTS18DCG2
Part number					
UTS618DCG2					
Part number					
UTS18DCG2					



# MPO

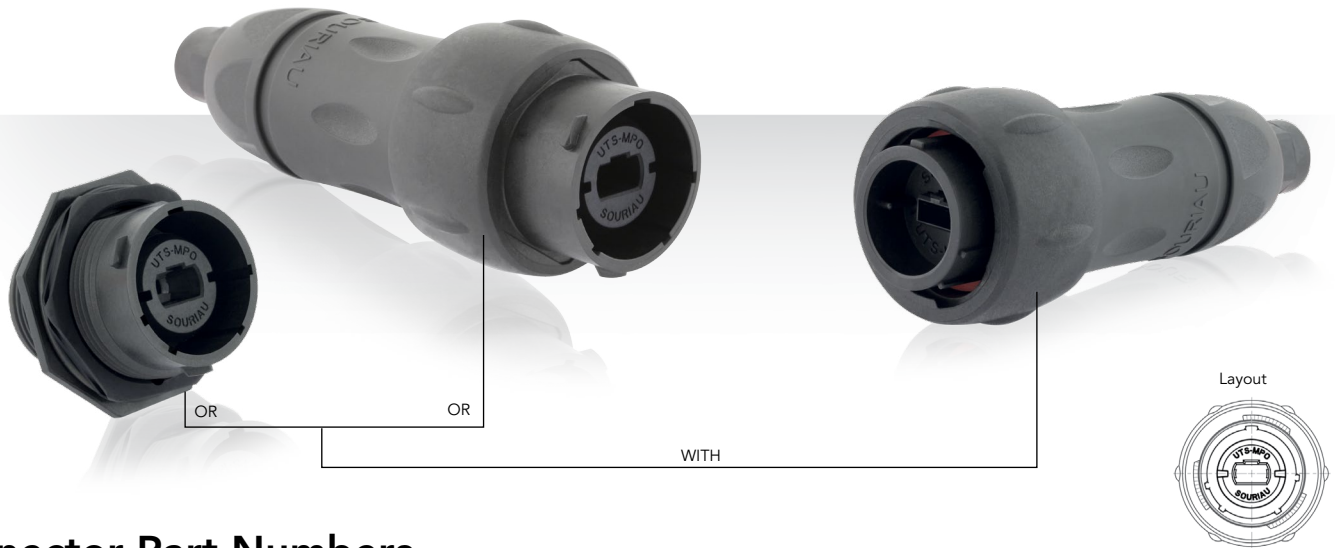

## Connector Part Numbers

Connector type	Backshell	Part number	
		Male insert	Female insert
Free hanging receptacle	Cable gland	<b>UTS1JC18MPN</b>	-
Plug	Cable gland	-	<b>UTS6JC18MPN</b>
Jam nut receptacle	Without	<b>UTS718MPN</b>	-

# MPO

## Dimensions

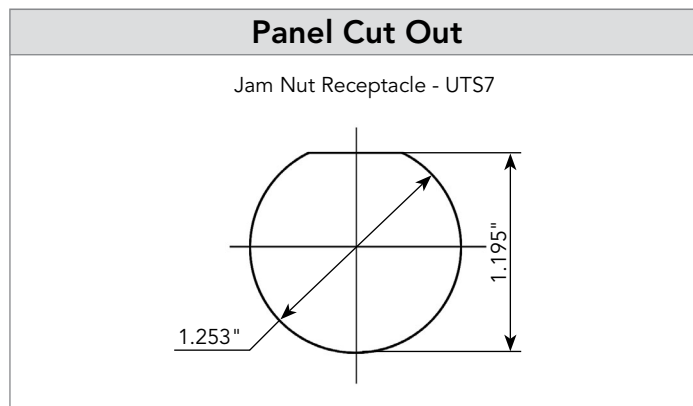
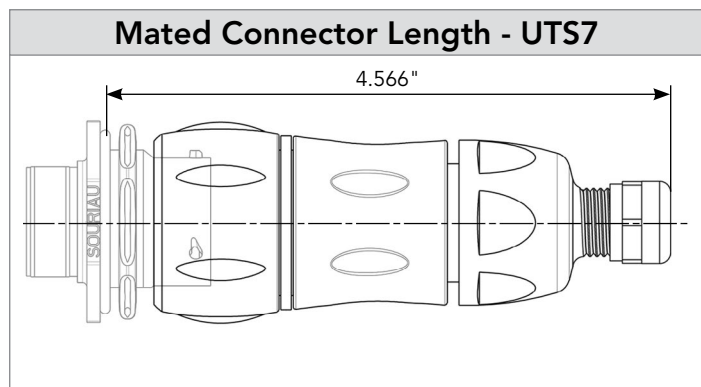
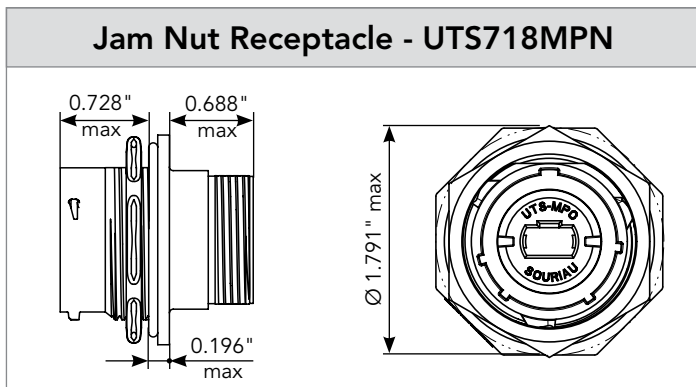
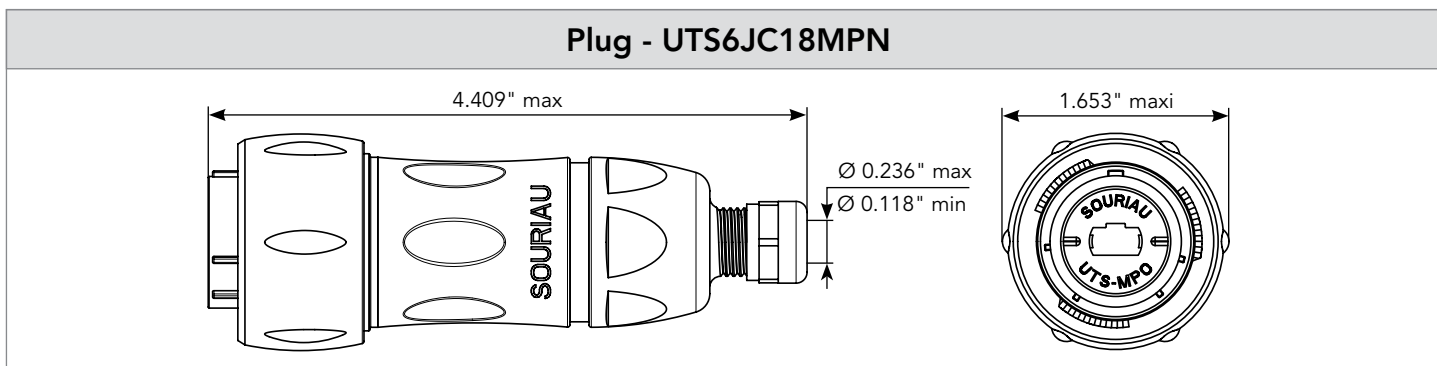
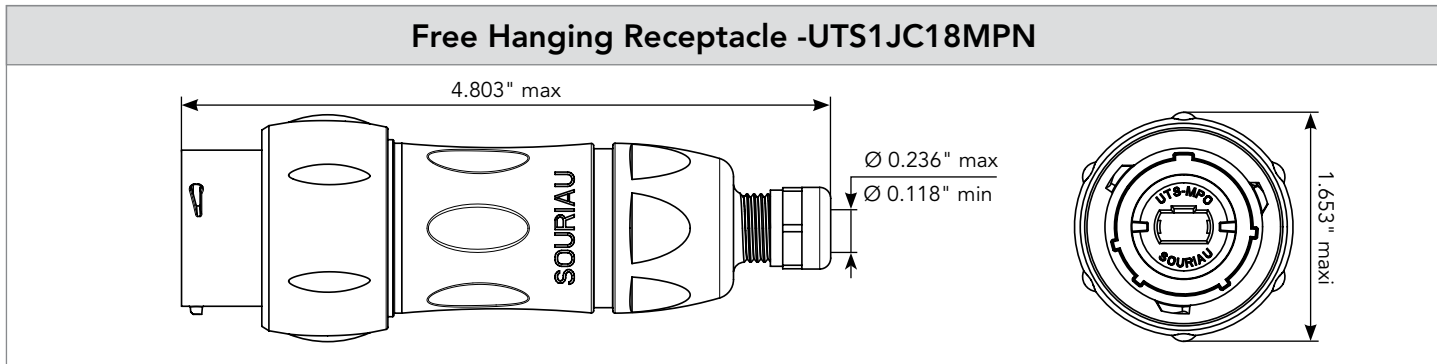

# MPO

## Accessories

Sealing Caps			
<p>For UTS6JC18MPN</p> 	<table border="1"><tr><td>Part number</td></tr><tr><td>UTS618DCG2</td></tr></table>	Part number	UTS618DCG2
Part number			
UTS618DCG2			
<p>For UTS1JC18MPN &amp; UTS718MPN</p> 	<table border="1"><tr><td>Part number</td></tr><tr><td>UTS18DCG2</td></tr></table>	Part number	UTS18DCG2
Part number			
UTS18DCG2			



# UTS SERIES



# Contacts

■ Description .....	162
■ Contact Plating Selector Guide .....	163
■ Contact Selector Guide .....	164
■ Packaging .....	164
■ Crimp Contacts .....	165
■ #16 Coaxial Contacts .....	167
■ PCB Contacts .....	168
■ Fiber Optic Contacts .....	169

## Contacts



### Description

The UTS series is delivered with (solder and PCB versions) or without contact (crimp version) and offers the unique feature to use the same contact style in any layout with the same active part size (i.e. #20, #16, #12, etc.). This provides our customers with an easy solution to buy only one type of contact to equip all their connectors even if housings/shell sizes are different.

This provides the benefit of standardisation and subsequent reduced inventory costs. In addition, it eliminates the need for added tooling and simplifies the assembly process. SOURIAU contacts are designed for simple snap-in installation and further eliminate the need for insertion tooling.

In addition to the below "crimp" style contact options, the UTS series can also be equipped with PCB contacts.

Crimp contacts are available in different versions:



• Machined



• Stamped & Formed



• Coaxial



• Fiber Optic

### Contact Plating Selector Guide

Once the contact size has been selected, the next step is to decide on which type to use. SOURIAU offers two main types of electrical contacts:

- Machined
- Stamped & Formed

Machined contacts are generally chosen as a better solution for power applications or when lower quantities are needed. Stamped & Formed contacts offer the ability to be crimped automatically which makes them more suitable for high volume production applications.

The next decision to make is: What plating should I choose?

The graph below can help guide you to plating recommendations based on application, mating cycles and current/voltage needs.

Note: do not mix different platings (i.e. tin plated pin contacts with gold plated socket contacts).

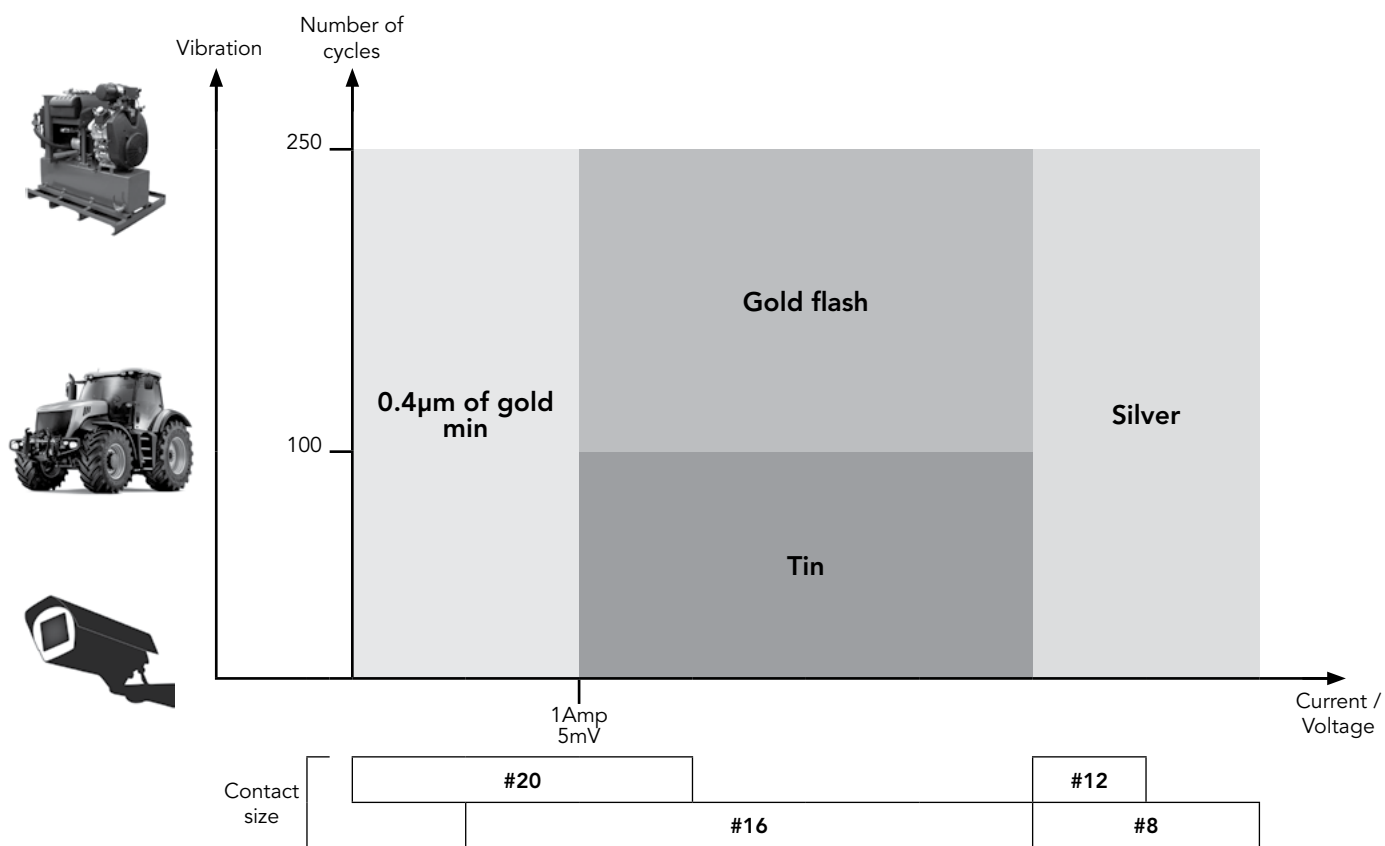

### Contact Selector Guide

#### Contact supplied separately

Electrical characteristics: contact resistance		
#20 Ø1mm	Machined	< 6mΩ
	Stamped & Formed	< 6mΩ
#16 Ø1.6mm	Machined	< 3mΩ
	Stamped & Formed	< 6mΩ
#12 Ø2.4mm	Machined	< 5mΩ
#8 Ø3.6mm	Machined	< 5mΩ

Available platings (contact supplied separately)	
A	2μ Ni + 2μ Ag
J	Gold flash over 2μ Ni
K	Min 0.4μ gold over 2μ Ni
S31	Active part: Gold flash over Ni Crimp area: Nickel
S18	Active part: 0.75μ gold min over 2μ Ni Crimp area: 1.3μ tin over Ni Other: Nickel
S25 S26	Active part: 0.75μ Au over Ni Crimp area: flash Au over Ni
TK6	2-5μ Sn pre-plated
D70	Superseded by S31
S6	Superseded by S18
Other platings on request (contact supplied separately)	
T	T: 2μ Ni mini all over + 3 to 5 μm Sn all over
D28	0.75μ gold over Ni
NPC	2 μm Ni

#### Contact preloaded

Electrical characteristics: contact resistance		
#20 Ø1mm	Machined	< 4mΩ
#16 Ø1.6mm	Machined	< 3mΩ

Available plating (contact preloaded)	
Min 0.4μ gold over 0.8μ Ni	

### Packaging

Due to the wide variety of applications, contact packaging is offered for small series (bulk package) and high volume production (reeled contacts):

#### Size contacts #20 (Ø1mm) & #16 (Ø1.6mm)



- 25 pieces loose package (Stamped & Formed contacts)



- 50 pieces bulk package (Machined contacts)



- 1,000 pieces bulk package (Machined contacts)

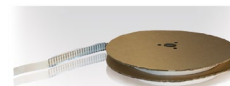

- 3,000 pieces reeled (Stamped & Formed contacts)

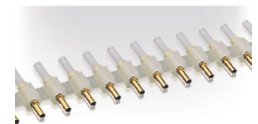

- 2,000 pieces reeled (Machined contacts)

#### Size contacts #12 (Ø2.4mm) & #8 (Ø3.6mm)



- 100 pieces bulk package (Machined contacts)

Note: 1,000 pieces bulk package available by adding 1000 at the end of the part number: e.g. RC16M23K1000  
2,000 pieces reeled package available by adding K at the beginning of the part number: e.g. KRC16M23K

## Crimp Contacts

### Standard Version



Contact size	Type	Wire size		Part number		Max wire Ø	Max insulator Ø	Available plating see page 156	
		AWG	mm <sup>2</sup>	Male	Female				
#20 Ø1 mm	Machined	26-24	0.13-0.20	RM24W3K	RC24W3K	-	1.58 max	K	
	Stamped & Formed	26-24	0.13-0.25	SM24W3 - (1)	SC24W3 - (1)	-	0.89-1.58	TK6 S25 (female) S26 (male)	
				SM24WL3 - (2)	SC24WL3 - (2)	-			
	Machined	22-20	0.32-0.52	0.35-0.5	RM20W3K	RC20W3K	-	1.58 max	K
					SM20W3 - (1)	SC20W3 - (1)	-	1.17-2.08	TK6 S25 (female) S26 (male)
			SM20WL3 - (2)	SC20WL3 - (2)	-				
	Machined	20-18	0.50-0.93	RM18W3K	RC18W3K	-	2.10 max	K	
#16 Ø1.6 mm	Machined	30-28	0.05-0.08	RM28M1 -	RC28M1 -	0.55	1.1	K, J	
	Machined	26-24	0.13-0.2	RM24M9 -	RC24M9 -	0.8	1.6	K, J	
	Stamped & Formed	26-24	0.13-0.25	SM24M1 - (1)	SC24M1 - (1)	0.89-1.28	Insulation grip	S31, S18, TK6	
				SM24ML1 - (2)	SC24ML1 - (2)				
	Machined	22-20	0.32-0.52	RM20M13 -	RC20M13 -	1.18	1.8	K, J	
				RM20M12 -	RC20M12 -		2.2		
	Stamped & Formed	22-20	0.35-0.5	SM20M1 - (1)	SC20M1 - (1)	1.17-2.08	Insulation grip	S31, S18, TK6	
				SM20ML1 - (2)	SC20ML1 - (2)				
	Machined	20-16	0.52-1.5	RM16M23 -	RC16M23 -	1.8	3.2	K, J	
	Stamped & Formed	18-16	0.8-1.5	SM16M1 - (1)	SC16M1 - (1)	3.0	No insulation grip	S31, S18, TK6	
SM16ML1 - (2)				SC16ML1 - (2)					
Stamped & Formed	18-16	0.8-1.5	SM16M11 - (1)	SC16M11 - (1)	2.0-3.0	Insulation grip	S31, S18, TK6		
			SM16ML11 - (2)	SC16ML11 - (2)					
Machined	16-14	1.5-2.5	RM14M30 -	RC14M30 -	2.28	3.2	K, J		
Stamped & Formed	14	2.0-2.5	SM14M1 - (1)	SC14M1 - (1)	3.2	No insulation grip	S31, S18, TK6		
			SM14ML1 - (2)	SC14ML1 - (2)					
#12 Ø2.4 mm	Machined	22	0.13-0.4	82911457N -	82911456 -	-	4.9	A, K	
		20	0.5	82911459N -	82911458 -				
		18	0.75-1.0	82911461N -	82911460 -				
		16	1.5	82911463N -	82911462 -				
		14	2.5	82911465N -	82911464 -				
		12	4	82911467N -	82911466 -				
#8 Ø3.6 mm	Machined	16	1.5	82913601A	82913600A	-	6.5	A	
		14	2.5	82913603A	82913602A				
		12	4	82913605A	82913604A				
		10	6.0	82913607A	82913606A				
		8	10.0	82913609A	82913608A				

(1) contact reeled (2) loose contact  
Example: RM24W3K - Size #20, Machined, AWG24 wire.

Note: all dimensions are in mm

### Crimp Contacts (Continued)

#### First Mate Last Break Contacts

Contact size	Type	Wire size		Part number		Max wire Ø (mm)	Max insulator Ø (mm)	Color band		Available plating see p. 156
		AWG	mm <sup>2</sup>	Male	Female			Front	Rear	
#16 Ø1.6 mm Longer male contact (+1mm)	Machined	30-28	0.05-0.08	RM28M1GE1K	-	0.55	1.1	-	Red	K
		26-24	0.13-0.2	RM24M9GE1K		0.8	1.6	Red	Red	
		22-20	0.32-0.52	RM20M13GE1K		1.18	1.8	Black	Red	
				RM20M12GE1K			2.2	Blue	Red	
		20-16	0.52-1.5	RM16M23GE1K		1.8	3.2	-	Red	
		16-14	1.5-2.5	RM14M30GE1K		2.28	-	-	Red	
#16 Ø1.6 mm Shorter female contact (-0.7mm)	Machined	30-28	0.05-0.08	-	RC28M1GE7K	0.55	1.1	-	Blue	K
		26-24	0.13-0.2		RC24M9GE7K	0.8	1.6	Red	Blue	
		22-20	0.32-0.52		RC20M13GE7K	1.18	1.8	Black	Blue	
					RC20M12GE7K		2.2	Blue	Blue	
		20-16	0.52-1.5		RC16M23GE7K	1.8	3.2	-	Blue	
		16-14	1.5-2.5		RC14M30GE7K	2.28	-	-	Blue	

#### How to make FMLB / LMFB connection

Contact 1 \ Contact 2	Standard male contact	Standard female contact	Longer male contact
Standard male contact		✓	
Standard female contact	✓		✓ FMLB
Shorter female contact	✓ LMFB		

First Mate Last Break contacts should be chosen only if the cavity is not marked with the ground symbol. For cavities marked with the ground symbol, standard contacts will fulfill the same role as a first mate, last break contact used in a standard cavity.



Ground symbol

## #16 Coaxial Contacts

### Coaxial Contact Range

SOURIAU provides 2 types of coaxial contacts suitable for 50 or 75Ω, coaxial cable or twisted pair cable.

#### Monocrimp coaxial contact

- The monocrimp one-piece coaxial contacts offer high reliability plus the economic advantage of a 95% reduction in installation time over conventional assembly methods.
- This economy is achieved by simultaneously crimping both the inner conductor and outer braid or drain wire.



#### Multipiece crimp coaxial contact

- The inner conductor and outer braid is crimped individually.
- The thermoplastic insulating bushing in the outer body is designed to accept and permanently retain the inner contact.
- An outer ferrule is used to connect the braid to the outer contact and provide cable support to ensure against bending and vibration.



#### Suitable for coaxial cable or twisted cable

- For jacket diameter from 1.78 to 3.05mm  
Inner conductor up to 2.44mm diameter



- For jacket diameter from 0.64 to 1.45mm  
Inner conductor from AWG30 to AWG24



#### Contacts for coaxial cable summary

Contact type	Contact range		Contact part number with cable combination	Cabling notice
	Male contact	Female contact		
Multipiece	RMDXK10D28	RCDXK1D28	See page 200	See pages 204 & 205
Monocrimp	RMDX60xxD28	RCDX60xxD28		See page 206

#### Contacts for twisted pairs cable summary

Contact type	Contact range		Contact part number with cable combination	Cabling notice
	Male contact	Female contact		
Multipiece	RMDXK10D28 + YORK090	RCDXK1D28 + YORK090	See page 201	See page 202
Monocrimp	RMDX60xxD28	RCDX60xxD28		See page 203

## PCB Contacts

### PCB Contacts Supplied Separately - UTS Standard Series

#### PCB soldering

The UTS Series can be used in a wave soldering process, but not reflow soldering process. All high temperature processes are prohibited.



Contact size	Part number		Plating see page 164
	Male	Female	
#20 Ø1mm	RMW50A7K RMW5016K	RCW50A7K RCW5016K	K
#16 Ø1.6mm	RM20M12E8K RM20M12E83K RM20M12E84K	RC20M12E8K RC20M12E83K RC20M12E84K RC20M12E85K RC20M12E86K RC20M12E87K	K
#8 Ø3.6mm	82911685NPC	82911684NPC	2 µm Ni

#### Minimal length G (mm)

Dimension of dipsolder contacts out of connector (contacts to be ordered separately).

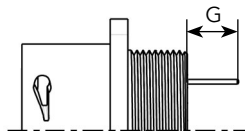

#### UTSØ with PCB contacts #16

Connector size	Pin contact			Socket contact			
	RM20M12E8K*	RM20M12E83K*	RM20M12E84K*	RC20M12E8K*	RC20M12E83K*	RC20M12E84K*	RC20M12E87K*
10	4.2	9.4	12.9	4.2	9.4	12.9	6.5
12	3.6	8.8	12.3	4.2	9.4	12.9	6.5
14	3.3	8.5	12.0	2.6	7.8	11.3	4.9
18	4.2	9.3	12.9	4.2	9.4	12.9	6.5

#### UTS7 with PCB contacts #20 and #16

Connector size	Pin contact				Socket contact		
	RM20M12E83K*	RM20M12E84K*	RMW50A7K*	RMW5016K*	RC20M12E84K*	RCW50A7K*	RCW5016K*
10	7.3	10.8	8.4	9.3	3.6	8.4	9.3
12	7.3	10.8	8.4	9.3	3.9	8.4	9.3
14	7.3	10.8	8.4	9.3	3.6	-	-
18	8.1	11.6	8.4	9.3	3.6	-	-

\* Plating indication see page 164

#### UTS7 with PCB contacts #16 and #8

Connector type	Pin contact		Socket contact	
	RM20M12E83K*	82911685NPC*	RC20M12E87K*	82911684NPC*
UTS7142G1P	-	6.4	-	-
UTS7142G1S	-	-	-	8.2
UTS7142G1SNPT	-	5.8	-	5.4
UTS718X2M3	4.9	4.5	3.6	5.2
UTS7183G1SNPT	-	-	-	4.17

\* Plating indication see page 164

Note: all dimensions are in mm



**PCB Contacts Loaded - UTS Sealed Unmated Series**

**PCB soldering**

The UTS Series can be used in a wave soldering process, but not reflow soldering process. All high temperature processes are prohibited.

**Nominal length G (mm)**

Dimension of dipsolder contacts out of connector (contacts to be ordered separately).

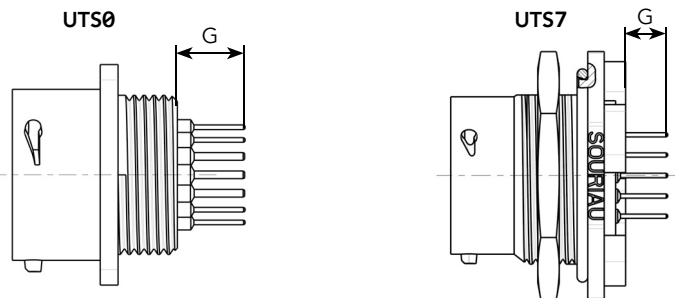

**UTS0**

Connector size	Connector Part Number	Pin contact		Socket contact	
		G mini	G maxi	G mini	G maxi
8	8D2 - 8D3 8D4	7.2	9.2	7	9
	8D3A/8D98 8D33	8.1	10.4	8.1	10.1
10	10D6 - 10D98 10D7	8.1	10.2	8.1	10.3
12	12D2 - 12D3 12D8 - 12D10	8.1	10.2	8.1	10.3
	12D4	8.2	10	8.1	10.3
	12D14	7.2	9	7.1	9.2
14	14D5 - 14D12 - 14D15 14D18 - 14D19	8.1	10.2	8.1	10.3
	14D7	8.2	10	8.1	10.3

**UTS7**

Connector size	Connector Part Number	Pin contact		Socket contact	
		G mini	G maxi	G mini	G maxi
8	8D2 - 8D3 8D4	3.8	6.1	3.7	5.9
	8D3A/8D98 8D33	4.7	7.3	4.7	7
10	10D6 - 10D98 10D7	4.7	7.3	4.7	7
12	12D2 - 12D3 12D8 - 12D10	4.7	7.3	4.8	7
	12D4	4.9	7.1	4.8	7
	12D14	3.9	6.2	3.8	6
14	14D5 - 14D12 - 14D15 14D18 - 14D19	4.8	7.3	4.9	7
	14D7	4.9	7.1	4.9	7

Note: all dimensions are in mm

## Fiber Optic Contacts

### Description

#### Size 16 fiber optic contacts for UTS and other TRIM TRIO® connectors

Size 16 fiber optic contacts are designed for the integration of optical links in UTS and other TRIM TRIO® cable connectors.

**The Fiber optic contacts are designed to accommodate:**

- Plastic Optical Fiber (POF) 1 mm core and 2.2 mm jacket

**Typical features and benefits are:**

- Socket contact is spring loaded to avoid any air gap between the two optical faces.
- Low insertion loss is provided by high precision pieces.
- Single jumpers, multiway harness and active device housings can be supplied regarding customer requirement.

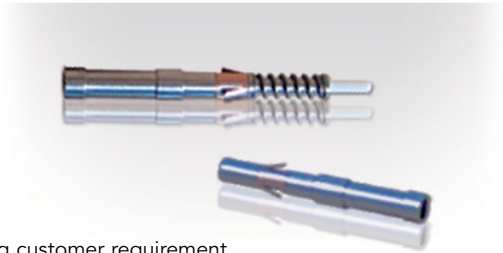

### Technical Characteristics

#### Performance

- Fiber type: ..... POF
- Wave length: ..... 650 nm
- Optical insertion loss (typ.): ..... 2 dB max.
- Jacketed external diameter: ..... 2.2mm
- Temperature range: ..... -25°C to +70°C
- Cable retention: ..... 49N
- Mating cycles without cleaning: ..... 50
- Max. mating cycles: ..... 500

#### Construction

- Contact body: Copper alloy

#### Connector accommodation

Any TRIM TRIO® size 16 contact can be used in any contact position in any connector in the TRIM TRIO® size 16 interconnection system: UTP, UTS, UTG, UTO, UTL.

### Ordering Information

**POF Contacts (Plastic Optical Fiber)**

Male contact ..... RMPOF1000

Female contact ..... RCPOF1000B

### POF Contact (Plastic Optical Fiber)

**STANDARD TOOLING KIT - P/N 80MS0004**

The *standard tooling kit* is made of the part numbers below that can be ordered separately as well.

Part numbers	Descriptions
80WD0005	Stripping tool
80WD0025	Automatic stripping tool for Ø 0.5 mm, 0.6 mm, 0.7 mm & 3.8 mm
80WM0006	Ruler
80WP0005	Polishing plate
80WP0013	Non slip base (to hold the polishing plate)
80WP0014	Polishing disk (grain size 9µm)
80WP0018	Polishing tool
80WP0019	Polishing disk (grain size 30µm)
80WS0002	Crimping plier

**SPECIFIC TOOLING LIST - Can only be ordered separately**

Part numbers	Descriptions
80WG0010	Needle
80WG0015	Capsule
80WG0016	Syringe
80WN0005	Dry air spray
80WN0006	Optical paper
80WN0012	Dropper bottle
80WN0008	Wiping solvent

# UTS SERIES

# Technical Information

■ Tooling .....	174
■ Crimping Instructions .....	176
■ Handle & Interchangeable Heads .....	178
■ Extraction Tools .....	179
■ Overmoulded Harnesses Dimensions .....	179
■ Assembly Instructions .....	180
■ Mated Connector Lengths .....	184
■ Mating Procedure .....	185
■ Rated Current & Working Voltage .....	186
■ UV Resistance .....	187
■ UL94 + UL1977 .....	188
■ IEC 61984 & IP Codes Explained .....	191
■ IEC 61140 Explained .....	193
■ What is NEMA Rating ? .....	194
■ Ethernet for the Layman .....	195

## Automatic Crimping Tools



# SOURIAU

**Mecal is a leader in manufacturing tooling for crimping terminals over a stripped wire.**

Established in 1976, Mecal has become one of the world's leading companies dedicated to the design and manufacture of semi automatic production tools for strip fed, open barrel crimp terminals, serving the Automotive, Telecom and Datacom industries.

**The extreme environment interconnect specialist "from deep sea to deep space".**

SOURIAU designs, manufactures and markets high performance interconnect solutions for severe environments dedicated to the aerospace, defense, light and heavy industry markets.

**SOURIAU has been working in partnership with Mecal for many years. With sales offices located in all major industrial regions of the world, the combined strengths of both organizations has resulted in a truly global solution to all your production tooling needs.**

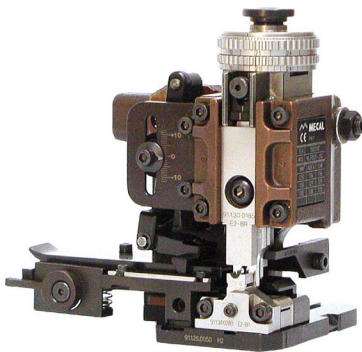

Mini Applicator

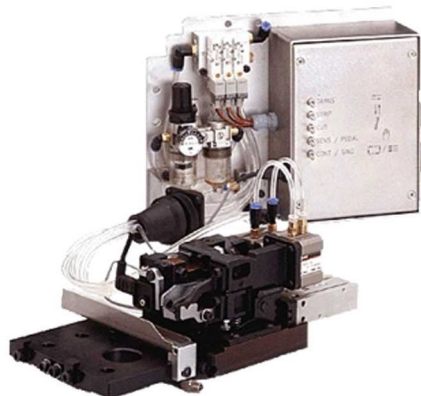

Stripper



Presses

Mecal sales network:

<http://www.mecal.net/index.php/en/europe>

## Tooling

### Crimp Tool Table

#### Standard contacts

Contact size	Part number	Head*	Handles*	Extraction tools
#20 Ø 1mm	RM/RC 24W3K	S2ØRCM	SHANDLES	RX2ØD44
	RM/RC 20W3K			
	RM/RC 18W3K			
	SM 24WL3S*(1)	S2ØSCM2Ø		
	SC 24WL3S*(1)			
SM/SC 2ØWL3S*(1)	S16RCM2Ø	RX2Ø25GE1		
RM/RC 28M1*				
RM/RC 24M9*				
RM/RC 2ØM13*				
RM/RC 2ØM12*				
RM/RC 16M23*		S16RCM16		
RM/RC 14M3Ø*		S16RCM14		
SM/SC 24ML1*(1)		S16SCM2Ø		
SM/SC 2ØML1*(1)		S16SCML1		
SM/SC 16ML1*(1)				
SM/SC 14ML1*(1)				
	SM/SC 16ML11*(1)	S16SCML11		

(1) loose contact \* endurance of SHANDLES & Head tools = 50,000 cycles

Contact size	Part number	Tool with separate locator			Extraction tools
		Hand tool	Positioner + locator setting		
#12 Ø 2.4mm	82911457N* / 82911456*	M317	VGE1ØØ77A	1-2	51Ø6Ø21Ø924
	82911459N* / 82911458*			2	
	82911461N* / 8291146Ø*			2	
	82911463N* / 82911462*			3	
	82911465N* / 82911464*			3	
	82911467N* / 82911466*			4	
#8 Ø 3.6mm	829136Ø1A / 829136ØØA	M317	VGE1ØØ78A	3	51Ø6Ø21Ø936
	829136Ø3A / 829136Ø2A			3	
	829136Ø5A / 829136Ø4A			4	
	829136Ø7A / 829136Ø6A			5	
	829136Ø9A / 829136Ø8A			6/7	

\* see page 157 for plating options and other contact details

#### Specific contacts (First mate Last break contacts)





Contact size	Part number*	Hand tools (SHANDLES) head	Tool with separate locator			Extraction tools			
			Hand tool	Positioner + locator setting					
#16 Ø 1.6mm Longer RM contact	RM28M1GE1K	S16RCM2Ø	-	-	-	RX2Ø25GE1			
	RM24M9GE1K								
	RM2ØM13GE1K								
	RM16M23GE1K	S16RCM16					MH86Ø	MH86186	6/8
	RM2ØM12GE1K	S16RCM14					-	-	-
RM14M3ØGE1K									
#16 Ø 1.6mm Shorter RC contact	RC28M1GE7K	S16RCM2Ø	MH86Ø	MH86164G	4/6				
	RC24M9GE7K				5/6				
	RC2ØM13GE7K				5/7				
	RC2ØM12GE7K	S16RCM16					6/8		
	RC16M23GE7K	S16RCM14			M317	UH25	3		

\* see page 166 for plating options and other contact details

#### Coaxial contacts

See coax contacts details on page 167 and cabling notice pages 202 to 206.

## Crimping instructions

Wire Stripping Crimp Version			
	Part number		Stripping length L
	Male	Female	
<b>Machined contact</b>	#20 (Ø 1mm)		
	RM24W3- / RM20W3- RM18W3-	RC24W3- / RC20W3- RC18W3-	4.8
	#16 (Ø 1.6mm)		
	RM28M1- / RM24M9- RM20M13- / RM20M12-	RC28M1- / RC24M9- RC20M13- / RC20M12-	4.8
	RM16M23- / RM14M30-	RC16M23- / RC14M30-	7.1
	#8 (Ø 3.6mm)		
	82913601- / 82913603- 82913605- / 82913607- 82913609-	82913600- / 82913602- 82913604- / 82913606- 82913608-	6.5 to 7.5
<b>Stamped &amp; Formed</b>	#16 (Ø 1.6mm)		
<b>With insulation support</b>	SM24M1- / SM24ML1- SM20M1- / SM20ML1-	SC24M1- / SC24ML1- SC20M1- / SC20ML1-	4
	SM16M11- / SM16ML11-	SC16M11- / SC16ML11-	4.65
	#20 (Ø 1mm)		
	SM24W3- / SM24WL3- SM20W3- / SM20WL3-	SC24W3- / SC24WL3- SC20W3- / SC20WL3-	4
<b>Without insulation support</b>	#16 (Ø 1.6mm)		
	SM16M1- / SM16ML1-	SC16M1- / SC16ML1-	6.35
	SM14M1- / SM14ML1-	SC14M1- / SC14ML1-	6.35
<b>Power contacts</b>	#12 (Ø 2.4mm)		
	82911457- / 82911459- 82911461- / 82911463- 82911465- / 82911467-	82911456- / 82911458- 82911460- / 82911462- 82911464- / 82911466-	7 to 8
	#8 (Ø 3.6mm)		
	82913601- / 82913603- 82913605- / 82913607- 82913609-	82913600- / 82913602- 82913604- / 82913606- 82913608-	6.5 to 7.5

Note: See page 165 for plating options and other contact details

Wire Stripping Solder and Screw Versions		
		Stripping length L
<b>Solder contact delivered with connector</b>	#16 (Ø 1.6mm) & #20 (Ø 1mm)	
		5
<b>Screw contact delivered with connector</b>	#16 (Ø 1.6mm)	
		5.8

Note: all dimensions are in mm



## Crimping

One of the key factors which affects the performance of a connector is the way contacts are terminated. Crimped connections are nowadays seen as the best solution to ensure quality throughout the lifetime of the product. Here are some reasons why we recommend this method of termination for UTS connectors:

**Advantages (Extract from the IEC 60352-2):**

- Efficient processing of connections at each production level
- Processing by fully-automatic or semi- automatic crimping machines, or with hand operated tools
- No cold-soldered joints
- No degradation of the spring characteristic of female contacts by the soldering temperature

- No health risk from heavy metal and flux steam
- Preservation of conductor flexibility behind the crimped connection
- No burnt, discolored and overheated wire insulation
- Good connections with reproducible electrical and mechanical performances
- Easy production control.

To ensure that the crimp tooling is performing according to original specifications, it is important to carry out regular checks. A common way to check the performance of tooling is with a simple pull test, ideally using a dedicated electric pull tester. Minimum recommended pull forces are indicated in the tables below:

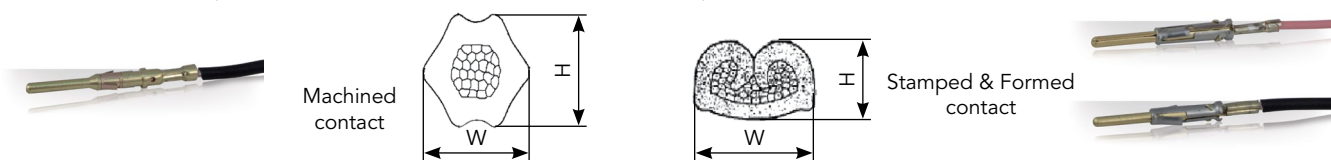

Active contact part	Contact type	Die location on heads	Wire section range	Section (mm <sup>2</sup> )	Tensile straight test (mini)	Height (mm) H (±0.075)	Width (mm) W (±0.075)	Tooling head p/n		
Machined contacts size #20 Ø 1 mm	RM24W3K RC24W3K	26/24	AWG 26	0.12 min	15 N	0.95	1.27	S20RCM		
			AWG 24	0.25 max	32 N					
	RM20W3K RC20W3K	22/20	AWG 22	0.32 min	40 N	1.26	1.78			
			AWG 20	0.50 max	60 N					
	RM18W3K RC18W3K	20/18	AWG 20	0.50 max	60 N	1.35	1.86			
			AWG 18	0.82 max	90 N					
S & F contacts size #20 Ø 1 mm	SM24WL3TK6* SC24WL3TK6*	26/24	AWG 26	0.12 min	15 N	0.80	1.49	S20SCM20		
			AWG 24	0.25 max	32 N					
	SM20WL3TK6* SC20WL3TK6*	22/20	AWG 22	0.32 min	40 N	1.01	1.53			
			AWG 20	0.50 max	60 N					
	Machined contacts size #16 Ø 1.6 mm	RM28M1K* RC28M1K*	30/28	AWG 30	0.05 min	11 N	1.14		1.41	S16RCM20
				AWG 28	0.08 max	11 N				
RM24M9K* RC24M9K*		26/24	AWG 26	0.12 min	15 N	1.15	1.41			
			AWG 24	0.25 max	32 N					
RM20M13K* RC20M13K*		22/20	AWG 22	0.32 min	40 N	1.26	1.76			
			AWG 20	0.50 max	60 N					
	AWG 20		0.32 min	40 N						
RM20M12K* RC20M12K*	22/20	AWG 20	0.50 max	60 N	1.66	2.18				
		AWG 20	0.50 max	60 N						
		AWG 20	0.50 max	60 N						
RM16M23K* RC16M23K*	20	AWG 20	0.50 max	60 N	1.80	2.28	S16RCM16			
		AWG 18	0.82 max	90 N						
		AWG 16	1.50 max	150 N						
RM14M30K* RC14M30K*	16	AWG 16	1.50 min	150 N	2.10	2.68	S16RCM14			
		AWG 14	2.50 min	230 N						
S & F contacts size #16 Ø 1.6 mm	SM24ML1TK6* SC24ML1TK6*	26/24	AWG 26	0.12 min	15 N	0.84	1.50	S16SCM20		
			AWG 24	0.25 max	32 N					
	SM20ML1TK6* SC20ML1TK6*	22/20	AWG 22	0.32 min	40 N	1.02	1.54			
			AWG 20	0.50 max	60 N					
	SM16ML11TK6* SC16ML11TK6*	18	AWG 18	0.82 min	90 N	1.32	2.09	S16SCML11		
			AWG 16	1.50 max	150 N					
	SM16ML1TK6* SC16ML1TK6*	18	AWG 18	0.82 min	90 N	1.49	2.02			
			AWG 16	1.50 max	150 N					
	SM14ML1TK6* SC14ML1TK6*	14	AWG 14	2.50 max	230 N	1.79	2.58	S16SCML1		
			AWG 14	2.50 max	230 N					

\*: example of plating options, for other plating see page 164

## Handle & Interchangeable Heads

### User Guide

- 1) Fully close then release the tool, keep it open.  
Open the 2 pins.



- 2) Choose the adapter head (sold separately), keep vertical and slide it into the handle until the mechanical end.

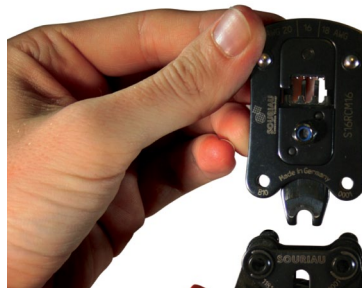

- 3) Close the two pins simultaneously to maintain the head.



- 4) Strip the cable properly check the recommended size in the catalog on page 176.

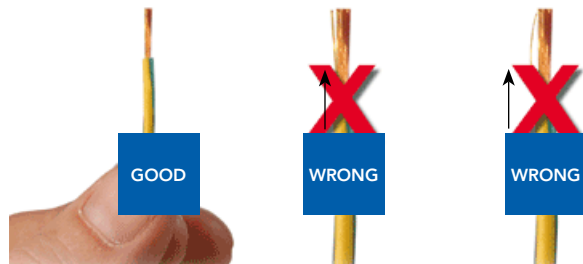

- 5) Place conductors, with no deteriorations, in the bucket contact.  
All strands to be located in the crimp bucket.



- 6) Position the contact in the bottom of the tool by checking its orientation.



- 7) To crimp contact assembly-cable, tighten sharply the clip to the end of the mechanism (maxi 175N).

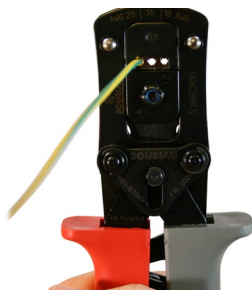

- 8) To control crimp quality, slightly pull cable with two fingers to control retention.

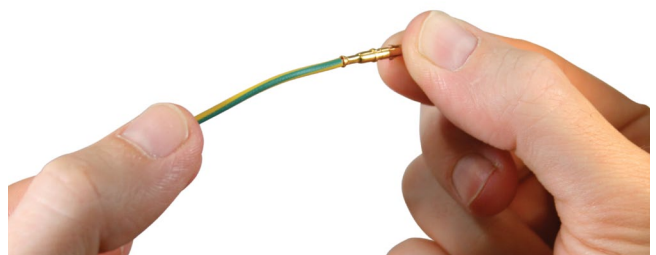

## Extraction Tools

Contact size	Extractor
#20 Ø 1 mm	RX20D44
#16 Ø 1.6 mm	RX2025GE1
#12 Ø 2.4mm	51060210924
#8 Ø 3.6mm	51060210936



## Contact extraction instruction

Place the tool into the cavity from front face of the connector, push on the handle, then remove the contact.

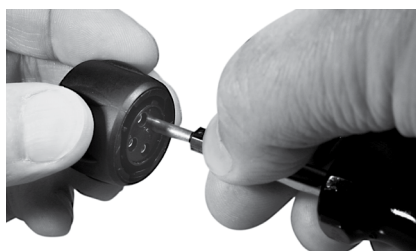

## Overmoulded Cable Assembly Dimensions

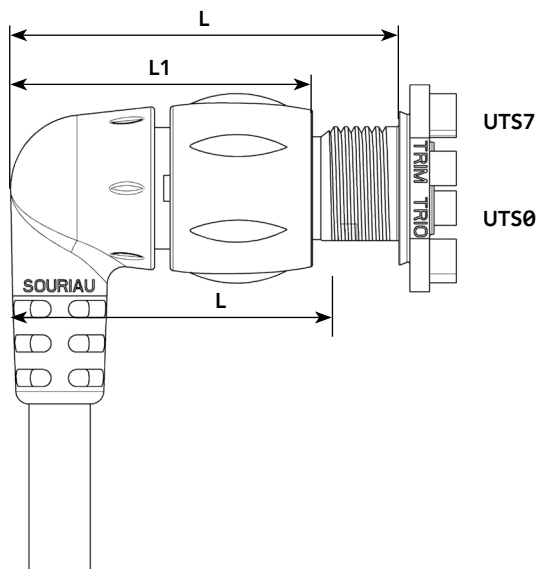

Shell size	UTS0				UTS7			
	L max	L1 max	L2 max	L3 max	L max	L1 max	L2 max	L3 max
8	42.8	36.8	80.7	57.2	46.8	36.8	85.8	57.2
10	55.8	50.3	98.6	92	60.5	50.3	102.7	92
12	57.1	51.4	99.3	93.7	61.4	51.4	106.4	93.7
14	62.5	56.3	100.3	94.6	67.6	56.3	104.8	94.6

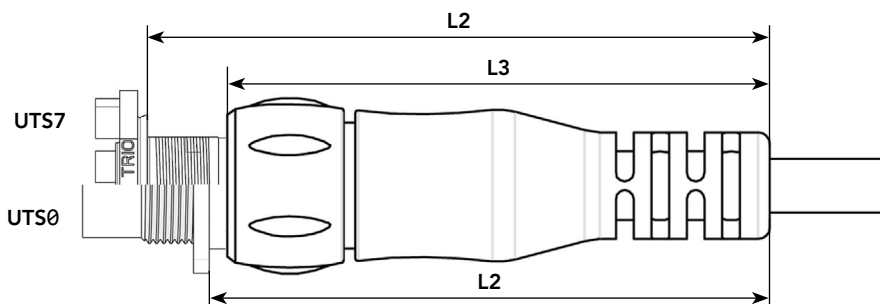

Note: all dimensions are in mm

## Assembly Instructions

### UTS0 Assembly (Mounting Suggestion)

- Strip wires, crimp or solder contacts (see pages 176 & 177)
- Insert contacts into connector cavities (insert manually or use tool RTM205 crimp contacts)
- Place receptacle in the panel cut-out
- Secure receptacle with screws (not supplied)  
Tighten screws: M2.5 (recommended torque: see table below)
- For complete sealing of the system use optional gasket and sealed screw solution (not sold by SOURIAU).

#### Front mounting: Crimp version

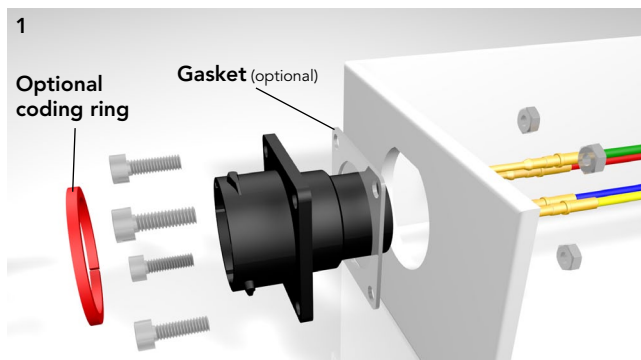

#### Rear mounting: Crimp version

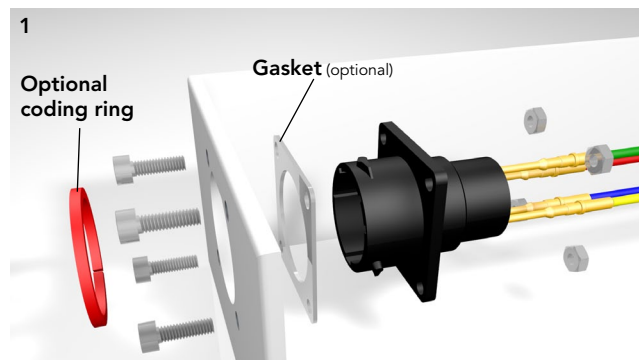

#### Front mounting: Solder version

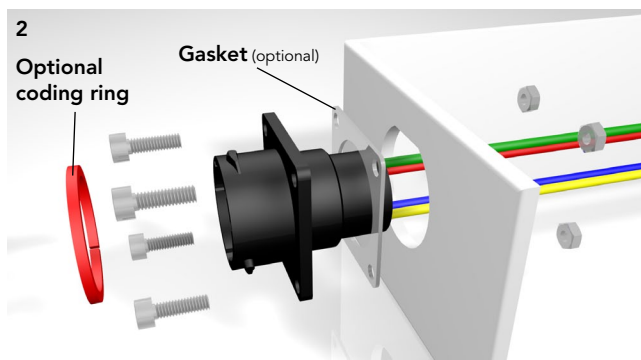

#### Rear mounting: Solder version

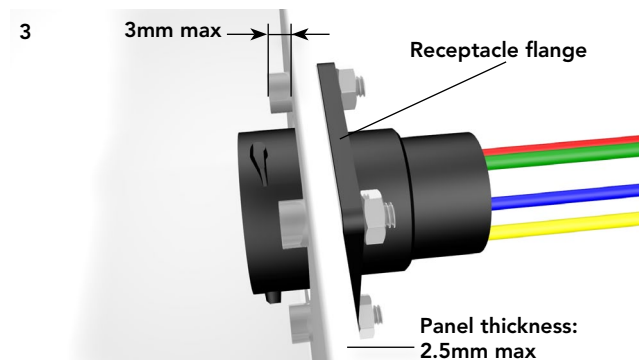
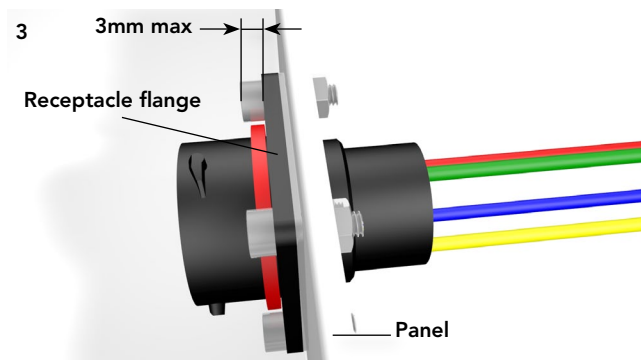
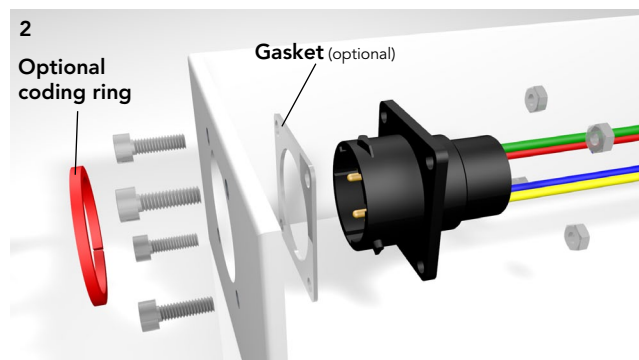

	Shell size				
	10	12	14	16	18
Screw tightening torque (Nm)	0.30/0.40	0.30/0.40	0.30/0.40	0.30/0.40	0.35/0.45

### UTS7 Assembly (Mounting Suggestion)

- Strip wires and crimp contacts (see pages 176 & 177)
- Insert contacts into connector cavities (insert manually or use tool RTM205 crimp contacts)
- Seat o-ring, place receptacle in the panel cut-out
- Tighten jam nut

Shell size	Jam nut torque (Nm) maxi	Exterior jam nut dim. (mm)	Ø Wire	
			Standard version	Discrete wire sealing
8	1.5	19.0	3.2 mm max.	from 1.7 mm to 3.0 mm
10	3	22.2		
12	4	27.0		
14	5	30.1		
18	5	36.5		

#### Threaded receptacle

Shell size	Jam nut torque (Nm) maxi	Threading	P mini (mm)
8	2.5	M12 x 1.5	7.7
10	3.75	M16 x 1.5	
12	3.75	M20 x 1.5	10.4
14	4.18	1/2"	8.3
18	4.76	3/4"	11.6

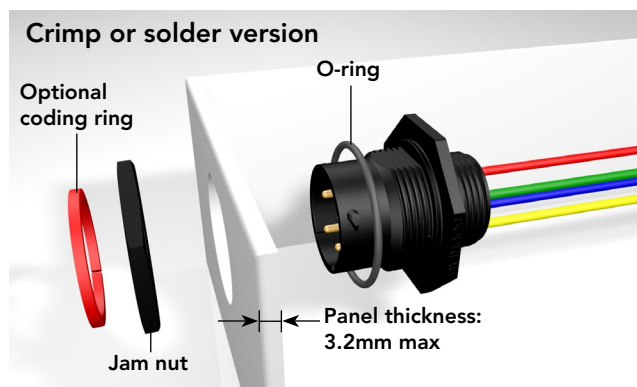

#### Threaded version

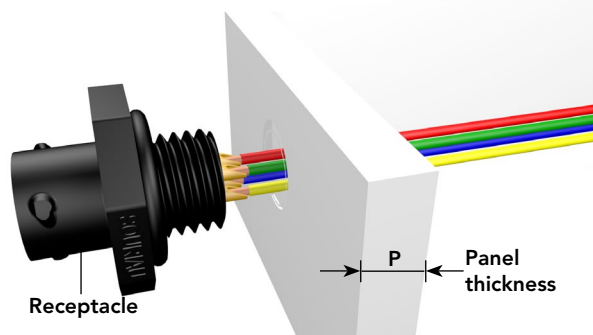

### UTS6 or UTS7 with GN Backshell Assembly

- Strip wires and crimp contacts (see pages 176 & 177)
- Insert first contact into the grommet (first contact in cavity A, no tool is required). Then insert the contact in the connector cavity A (insert manually or use tool RTM205)
- Insert the other contacts
- Tighten the nut to rear of either UTS6 or UTS7 (recommended torque values to be applied according to the table below).

Shell size	layout	Nut tightening torque (Nm)	Ø Wire
10	4	1	From 1.7 mm to 3.0 mm
12	8	1.5	
14	7	1.5	
14	12	1.5	

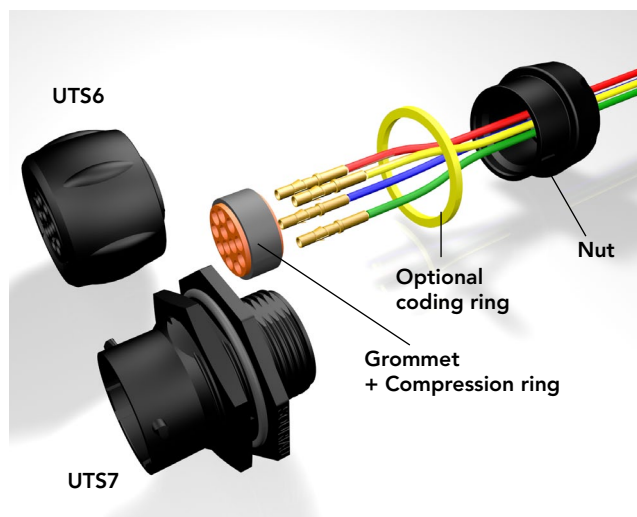

## Assembly Instructions (Continued)

### UTS1JC or UTS6JC Assembly: Crimp Version

- Slide accessories onto the cable

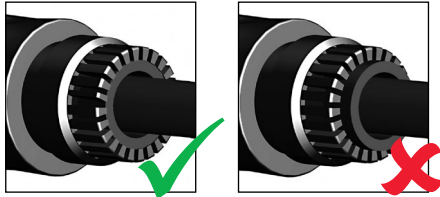

Make sure the seal is positioned as shown.

- Mate the plug with a corresponding counter part
- Strip external cable jacket
- Strip wires and crimp contacts (see pages 176 & 177)
- Insert contacts into connector cavities (insert manually or use tool RTM205)
- Tighten adapter with plug UTS6 or receptacle UTS1, choose right seal (waste the other seal)
- Tighten the nut to rear of either UTS1 or UTS6 (recommended torque values to be applied according table to the right)
- Caution: only one of both delivered gasket should be used !

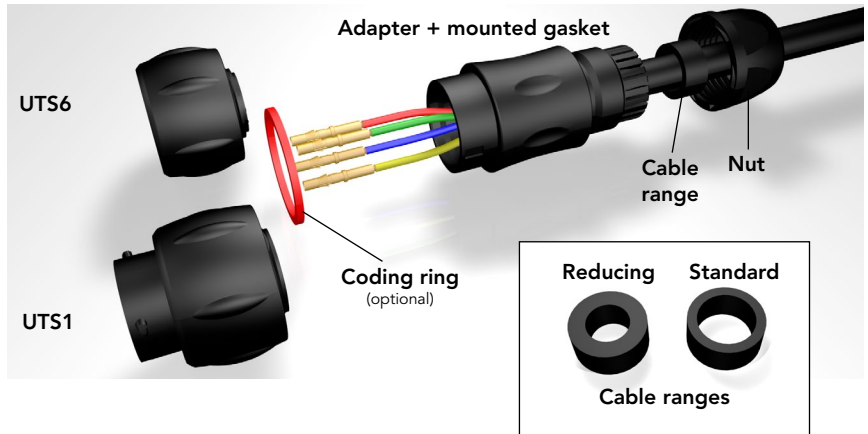

Shell size	Recommended jacket strip length (mm)		Adapter tightening torque (Nm)	Nut tightening torque (Nm)	Ø Cable range Standard seal	Ø Cable range Reducing seal	Ø Wire
	Male	Female					
10	21	29	1.5	1	2.5/8.0	1.5/5.0	From 1.7 mm to 3.0 mm
12	25	33	2	2.5	5.0/12.0	3.0/9.0	
14	29	36	3	2.5	7.0/14.0	5.0/12.0	
18	37	45	4	3.5	9.0/18.0	7.0/16.0	

### UTS6JC Assembly: Solder Version

- Slide accessories onto the cable

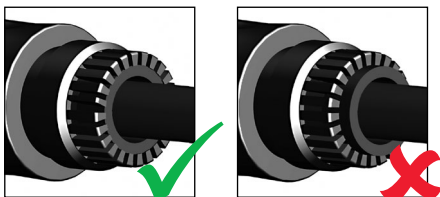

Make sure the seal is positioned as shown.

- Mate the plug with a corresponding receptacle
- Strip external cable jacket
- Strip wires and crimp contacts (see pages 176 & 177)
- Insert contacts into connector cavities (insert manually or use tool RTM205)
- Tighten adapter with plug, choose right seal (waste the other seal)
- Tighten the nut to rear of either UTS6 (recommended torque values to be applied according table to the right)
- Caution: only one of both delivered gasket should be used !

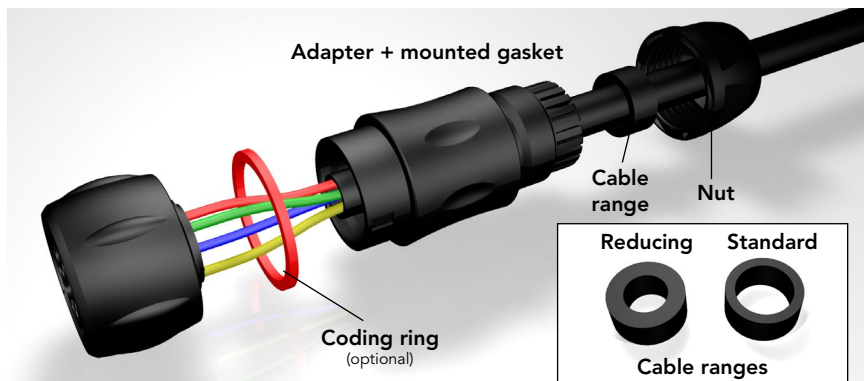

Shell size	Recommended jacket strip length (mm)		Adapter tightening torque (Nm)	Nut tightening torque (Nm)	Ø Cable range Standard seal	Ø Cable range Reducing seal	Ø Wire
	Male	Female					
8	17		1	0.75	2.5/6.5	1.5/5.0	From 1.7 mm to 3.0 mm
10	21		1.5	1	2.5/8.0	1.5/5.0	
12	25		2	2.5	5.0/12.0	3.0/9.0	
14	29		3	2.5	7.0/14.0	5.0/12.0	

Note: all dimensions are in mm

### UTS6JC Screw Termination Assembly

- Mate the plug with a corresponding receptacle equipped with its contacts
- Choose and place right seal depending on cable diameter (see table below)

- Slide accessories on the cable
- Strip external jacket (see table below).

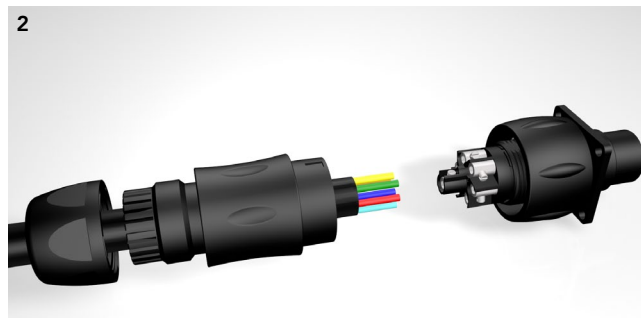
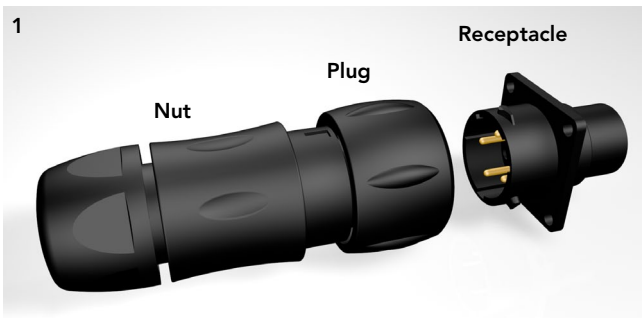

- Strip the wires (strip length 5.8 mm)

- Place the conductors in the contact barrel. Make sure all conductor strands are inside the barrel
- Tight the contact screws, advised torque 20 Ncm

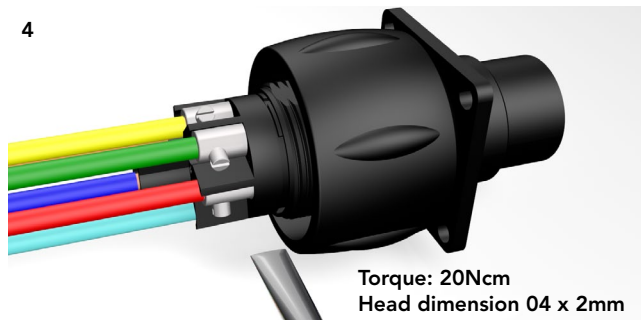
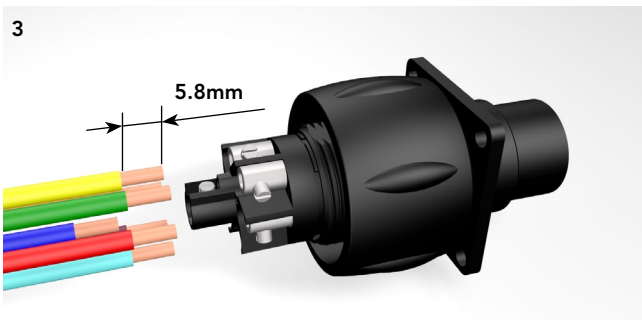

- Check the mechanical cable retention, by gently pull the cable with 2 fingers
- Tighten adaptater with the plug (recommended torque: see table)

- Tighten backshell nut with adapter (recommended torque: see table below) (cables should not turn into the backshell during this operation).



Shell size	Recommended jacket strip length (mm)		Adapter tightening torque (Nm)	Nut tightening torque (Nm)	Ø Cable range Standard seal	Ø Cable range Reducing seal	Ø Wire
	Male	Female					
12	22.8 max	15.1 max	2	2.5	5.0/12.0	3.0/9.0	From 1.7 mm to 3.0 mm
14	26.7 max	18.9 max	3	2.5	7.0/14.0	5.0/12.0	

Note: all dimensions are in mm

## Assembly Instructions (Continued)

### UTS1GJC or UTS6GJC Assembly

- Slide accessories onto the cable (make sure to keep compression ring on the grommet)
- Strip external cable jacket
- Strip wires and crimp contacts (see pages 176 & 177)
- Insert first contact into the grommet (first contact in cavity A, no tool is required). Then insert the contact in the connector cavity A (insert manually or use tool RTM205)
- Place the grommet and compression ring on the insulator
- Insert the other contacts
- Tighten adapter with plug UTS6 or receptacle UTS1, choose right seal(waste the other seal)
- Tighten the nut to rear of either UTS1 or UTS6 (recommended torque values to be applied according to the table right).

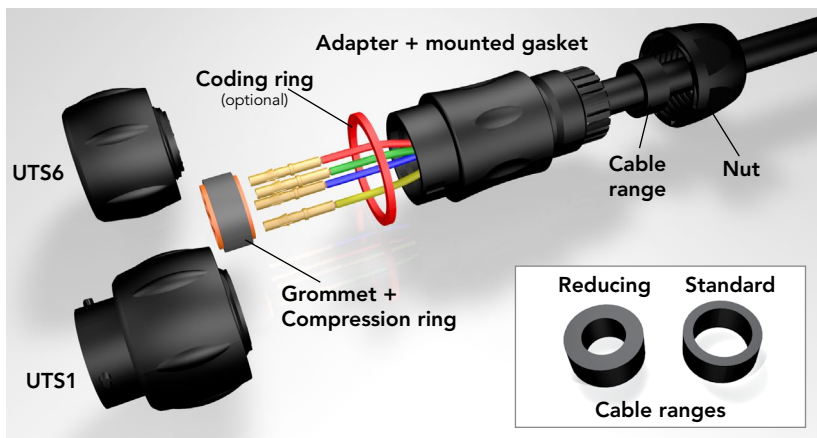

Shell size	Recommended jacket strip length (mm)		Adapter tightening torque (Nm)	Nut tightening torque (Nm)	Ø Cable range Standard seal	Ø Cable range Reducing seal	Ø Wire
	Male	Female					
10	21	29	1.5	2	2.5/8.0	1.5/5.0	from 1.7 mm to 3.0 mm
12	25	33	2	2.5	5.0/12.0	3.0/9.0	
14	29	36	3	2.5	7.0/14.0	5.0/12.0	

### Mated Connector Lengths

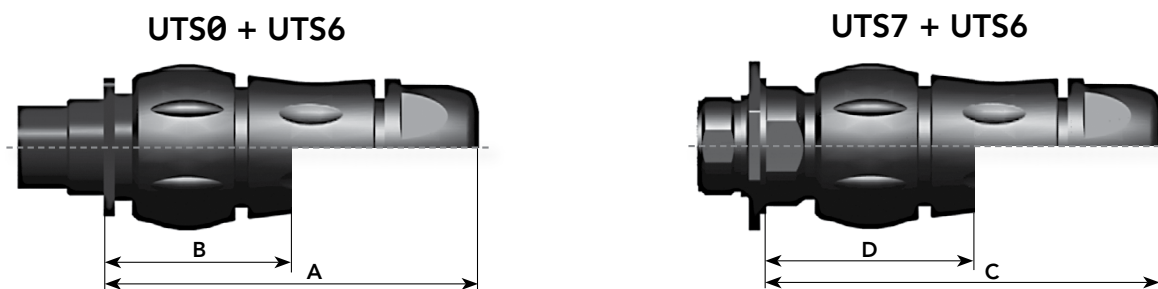

Shell size	UTS0 + UTS6 JC & GJC	UTS0 + UTS6 GN	UTS7 + UTS6 JC & GJC	UTS7 + UTS6 GN
	A max	B max	C max	D max
8	61.1	-	66.6	-
10	73.2	39.6	77.3	43.7
12	77.6	39.4	81.7	43.5
14	83.5	40	87.6	44.1
18	93.1	-	97.2	-

Note: all dimensions are in mm



## Mating Procedure

### UTS Coupling Procedure

The pictures below provide step by step instructions on how to mate a plug and receptacle connector in order to avoid damaging any of the contacts.

- Identify the primary key of each connector.



- Align the primary keys of the connectors.

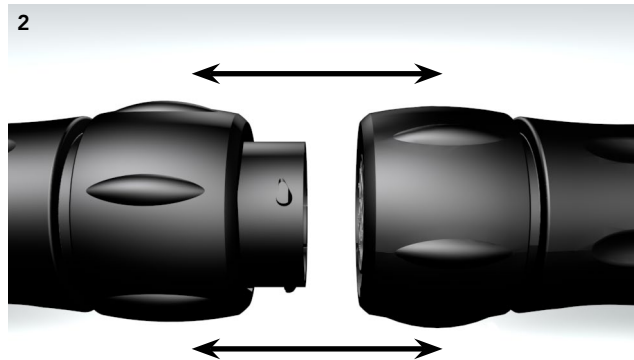

Non correct positioning:



- Offer the plug to the receptacle.

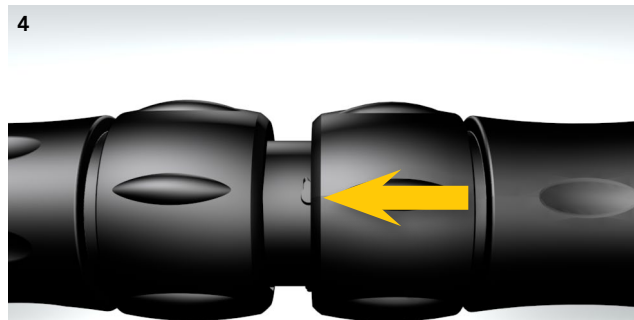

- Turn coupling ring until you hear a 'click'

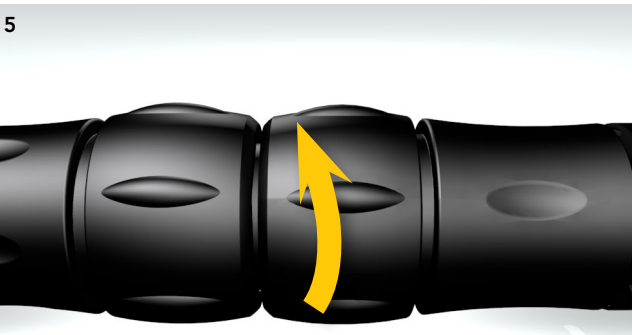

Fastening of cable: In order to avoid any mechanical stress on the connection, cable could be clamp closed to the connector in such a way there is no bending or traction applying on the connector.

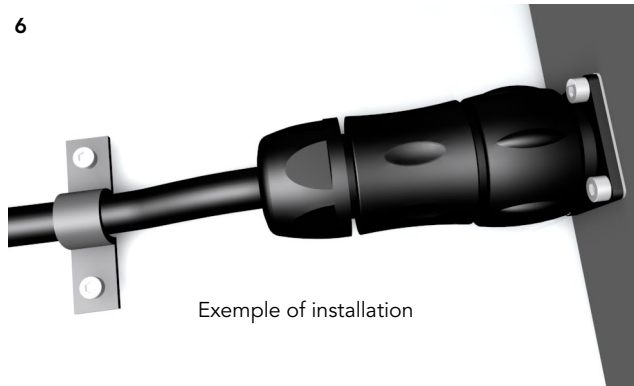

## Rated Current & Working Voltage

### Current Carrying Capacity

The current carrying capacity of a connector is limited by the thermal properties of materials used in its construction. The amount of current that can be handled depends on the size of cable used, the ambient temperature and the heat that is generated inside the connector. Part 3 of the IEC 60512 standard determines through a derating curve, the maximum current permissible, which varies from one layout to another (Fig.1 & Fig.2). Wire size plays an important role in dissipating heat and avoid overheating (Fig.1 & Fig.3).

Please note that the curve should be adjusted when dealing with potential hot spots, which can occur as a result of unequal loading of current across a number of contacts. As a general rule, it is best to avoid placing power handling contacts in the middle of the connector; try to locate them towards the edge where heat can be dissipated more effectively. Eventually you should find a level which represents the permissible operating range:

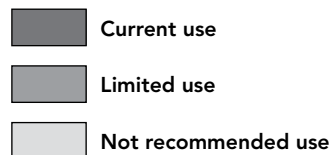
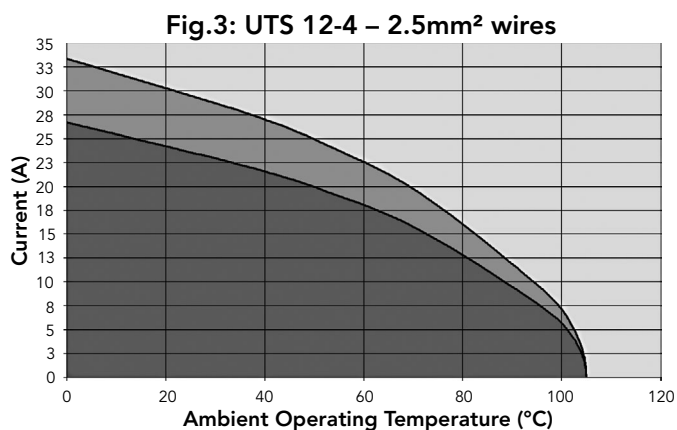
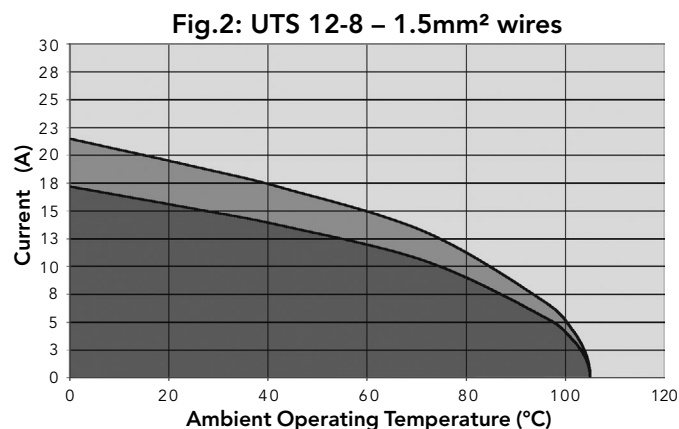
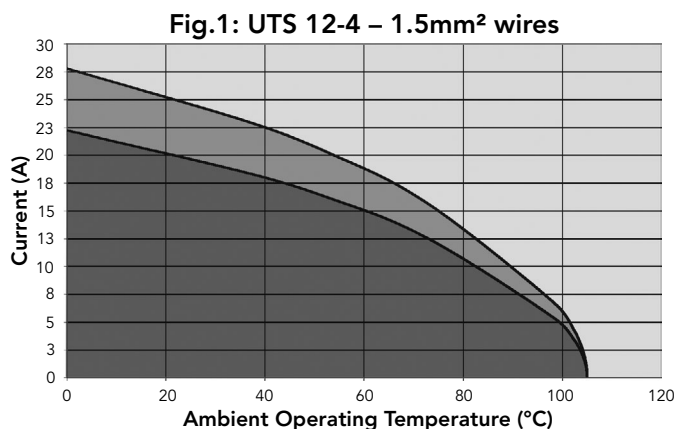

The **rated current** is defined as uninterrupted continuous current that a connector can take when all contacts are energized simultaneously without exceeding the maximum limit of temperature. The earth contact is never loaded.

## UV Resistance

### Exposure in Natural Environment

Solar radiation affects all materials, but plastics can be susceptible to extreme degradation over time. The choice of materials for the UTS series was therefore a critical consideration.

All over the world we are not exposed to the same amount of energy given by the sun. The chart shown here clearly illustrates this.

So we performed test according to the ISO 4892-2 and simulated 5 years exposure to outdoor environments (temperature, humidity, etc...) After this period there was no significant colour variation, no crazing, no cracking and no major variation of mechanical properties.

Yearly mean of daily irradiation in UV (280-400 nm) on horizontal plane (J/cm<sup>2</sup>) (1990-2004)

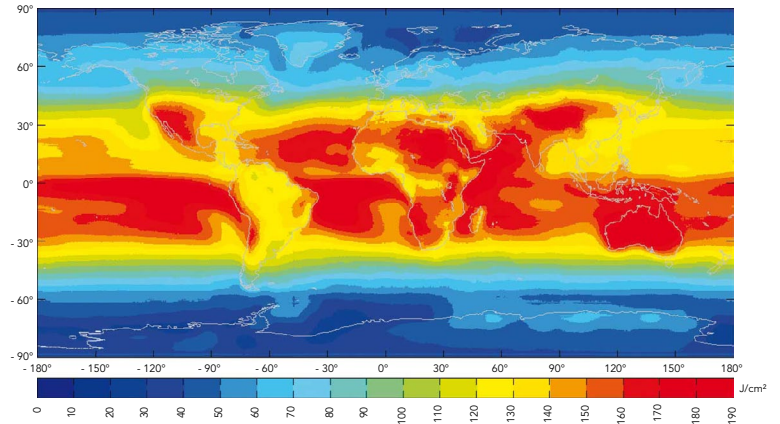

## UL94 + UL1977



There are two main standards for industrial connectors: UL94 & UL1977

### UL94

This standard is dedicated to plastics flammability. It characterises how the material burns in various orientation and thicknesses.

The UTS series has been rated at **V-0** & **HB**.

Procedure: A specimen is supported in a vertical or horizontal position and a flame is applied to the bottom of the specimen. The flame is applied for ten seconds and then removed until flaming stops, at which time the flame is reapplied for another ten seconds and then removed. Two sets of five specimens are tested.

#### V-0 Vertical burning:

- Specimens must not burn with flaming combustion for more than 10 seconds after each test flame application
- Total flaming combustion time must not exceed 50 seconds for each set of 5 specimens
- Specimens must not burn with flaming or glowing combustion up to the specimen holding clamp
- Specimens must not drip flaming particles that ignite the cotton
- No specimen can have glowing combustion remain for longer than 30 seconds after removal of the test flame.

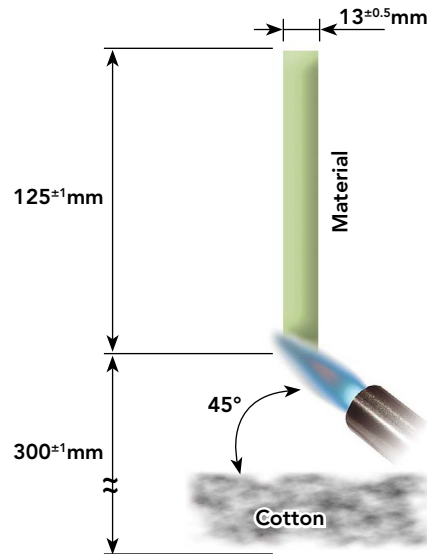

#### HB Horizontal burning:

- A material classified HB shall not have a burning rate exceeding 40 mm per minute over a 75 mm span for specimens having a thickness of 3.0 to 13 mm
- A material classified HB shall not have a burning rate exceeding 75 mm per minute over a 75 mm span for specimens having a thickness less than 3.0 mm
- A material classified HB shall cease to burn before the 100 mm reference mark.

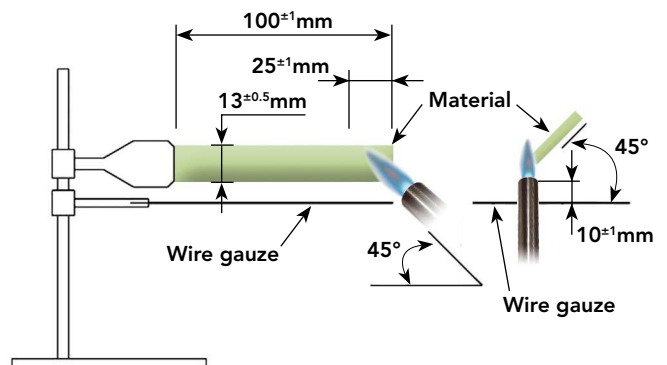

## UL1977

There are several standards which deal with plug and receptacle. Each of them is only for a small area of applications. It could be telecommunication, etc. The UL 1977 covers single and multipole connectors intended for factory assembly.

Requirements apply to devices taking into account intensity and voltage. The categories are as follows:

	0	30 V (42 V peak)	600 V
0	Type 0		Type 1A
31 A	Type 1B		Type 2
			Type 3
1000 A	Type 4		

According to above table, the level of performance that has to be reached could be different. Most of them are explained in the following page.

### Insulating materials:

Material uses for electrical insulation, as a minimum, have to comply with the characteristics shown below:

- Minimum ratings for polymeric materials

Type	Flame rating	Relative thermal index (RTI) Electrical/mechanical w/o impact */**
0	-	50/50
1A	HB	50/50
1B	HB	50/50
2	HB	50/50
3	HB	50/50
4	HB	50/50

\* The RTI of the material shall not be lower than the temperature measured during the Temperature Test.

\*\* For a thickness less than that for which a value has been established, the RTI of the minimum thickness with an established value shall be used.

### Assembly:

Connector has to be keyed to prevent any mismatching that can damage the machine or hurt the user. In the same way, plugs and sockets have to be equipped to protect persons against contact with live parts.

Finally the identified grounding contact shall be located so that the corresponding electrical continuity has to be completed before any other contact.

## UL94 + UL1977 (Continued)



### UL1977

#### Spacing:

For a 250V max connector, distance through air or over material shall be 1.2mm whereas from 250V to 600V connector the spacing is 3.2mm minimum. These distances have to be taken between uninsulated live parts as shown in the matrix below:

• **Applicability of spacing requirements**

Type	Uninsulated live part - uninsulated live part of opposite polarity	Uninsulated live part - uninsulated grounded metal part	Uninsulated live part - exposed dead metal part
0	No	No	No
1A	Yes	Yes	Yes
1B	Yes	Yes	No
2	Yes	Yes	Yes
3	Yes	Yes	Yes
4	Yes	Yes	Yes

An alternative way to determine voltage rating is with the Dielectric-Withstand test. If during one minute there is no arc-over or breakdown the rated voltage is given as shown below:

- a) 500 volts for a type 1B device
- b) 1000 volts plus twice rated voltage for types 1A, 2, 3 and 4 devices.

#### Marking:

A device shall be legibly marked with the manufacturer's trade name, trade mark, or other descriptive marking by which the organisation responsible for the product may be identified. (Exception: If the device is too small, or where the legibility would be difficult to attain, the manufacturer's name, trademark, or other descriptive marking may appear on the smallest unit container or carton)

The following shall be marked on the device or on the smallest unit container or carton or on a stuffer sheet in the smallest unit container or carton:

- a) The catalog number or an equivalent designation
- b) The electrical rating in both volts and amperes, if assigned
- c) Whether ac or dc, if restricted
- d) Flammability class, if identified

Example - Marking for the arrangement 10-3: 10A 500V UL94 V-0

# IEC 61984 & IP Codes Explained

## IEC 61984

The norm is dedicated to connectors with rated voltage above 50V and up to 1000V and rated currents up to 125A per contact. Depending on your application connectors should be compliant with another standard. This has to be double checked with the customer.

There are a lot of constructional requirements and performances specified in that standard. Most of them are illustrated in greater details hereafter.

### Provisions for earthing:

The UTS connector is intended to be used on Class I or Class III (see IEC 61140) systems. Even if the purpose of our connector is not to interrupt current, there is a need to add a protective earth contact. This one shall be a "First mate, last break" style. Critically, among all of the normal assumptions we make in designing a connector, this contact has to be considered as a live part and must be protected attached to the ground wire.

### IP Code:

IP is a coding system defined by the IEC 60529 to indicate the degrees of protection provided by an enclosure. The aim of this is to give information regarding the accessibility of live parts against ingress of water and other foreign bodies.

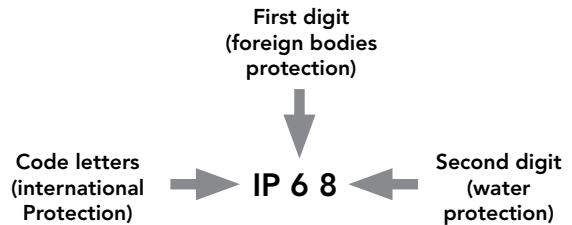

1 <sup>st</sup> digit	Degree of protection	2 <sup>nd</sup> digit	Degree of protection
0	No protection against accidental contact. No protection against solid foreign bodies.	0	No protection against water.
1	Protection against contact with any large area by hand and against large solid foreign bodies with a diameter bigger than 50 mm.	1	Drip-proof. Protection against vertical water drips.
2	Protection against contact with the fingers. Protection against solid foreign bodies with a diameter bigger than 12 mm.	2	Drip-proof. Protection against water drips up to a 15° angle.
3	Protection against tools, wires or similar objects with a diameter bigger than 2.5 mm. Protection against small solid bodies with a diameter bigger than 2.5 mm.	3	Spray-proof. Protection against diagonal water drips up to a 60° angle.
4	Same as 3 however diameter is bigger than 1 mm.	4	Splash-proof. Protection against splashed water from all directions.
5	Full protection against contact. Protection against interior injurious dust deposits.	5	Hose-proof. Protection against water (out of a nozzle) from all directions.
6	Total protection against contact. Protection against penetration of dust.	6	Protection against temporary flooding.
		7	Protection against temporary immersions.
		8	Protection against water pressure. Pressure to be specified by supplier.

UTS offers high sealing performance IP68 / 69K... Even in dynamic situations.

In addition to the IEC 60529 we conjointly use the DIN 40050 part 9 which are dedicated to road vehicles. The main differences are:

- **First digit:** 5 replaced by 5K, 6 by 6K. In the DIN the tested equipment is not depressurized as it is in the IEC.
- **Second digit:** 5K and 6K has been added and are equivalent respectively to 5 and 6 but with higher pressure. 9K which represents the High pressure cleaning.

9K	High pressure hose-proof. Protection against high pressure water (out of a nozzle) from all directions.
----	--

IEC 61984 ed.2.0 "Copyright © 2008 IEC Geneva, Switzerland.www.iec.ch"  
IEC 60664-1 ed.2.0 "Copyright © 2007 IEC Geneva, Switzerland.www.iec.ch"

## IEC 61984 & IP Codes Explained (Continued)

### IEC 61984

#### Overvoltage

UTS connectors are qualified to be used on systems rated at Overvoltage category III

Per the IEC 60664-1 (formerly VDE 0110) each category is linked to the end application and where the device will be implemented:

- **Category IV** (primary overcurrent protection equipment):  
Origin of the installation
- **Category III** (any fixed installation with a permanent connection)  
Fixed installation and equipment and for cases where the reliability and the availability is subject to special requirements
- **Category II** (domestic appliances):  
Energy consuming equipment to be supplied from the fixed installation
- **Category I** (protected electronic circuit):  
For connection to circuit in which measures are taken to limit transient overvoltage.

#### Pollution degree

Per the IEC 60664-1 (formerly VDE 0110) the environment affects the performance of the insulation. Particles can build a bridge between two metal parts. As a rule dust mixed with water can be conductive and more generally speaking metal dust is conductive. Finally, the standard defines 4 levels of pollution:

- **Degree 1** (Air conditioned dry room):  
No pollution or only dry, non conductive pollution occurs. The pollution has no influence.
- **Degree 2** (Personal computer in a residential area):  
Only non conductive pollution occurs except that occasionally a temporary conductivity caused by condensation is to be expected.
- **Degree 3** (Machine tools):  
Conductive pollution occurs or dry non-conductive pollution occurs which becomes conductive due to condensation which is to be expected.
- **Degree 4** (Equipments on roof, locomotives):  
Continuous conductivity occurs due to conductive dust, rain or other wet conditions.

Finally, the harsher the environment is, the longer clearance and creepage distances should be. Nonetheless, according the IEC 61984, enclosure rated at IP54 or higher can be dimensioned for a lower pollution degree. This applies to mated connectors disengaged for test and maintenance.

#### Marking

The marking should give enough details to the user to know what the main characteristics are and without going deep in technical documentation. Below examples identify the suitability of the connector:

- **Example 1:**  
Marking of a connector with rated current 16A, rated voltage 400V, rated impulse voltage 6kV and pollution degree 3, 2 and 1 for use in any system, preferably unearthed or delta-earthed systems:

16A 400V 6kV 3

- **Example 2:**  
Marking of a connector with rated current 16A, rated insulation voltages line-to-earth 250V, line-to-line 400V, rated impulse voltage 4kV and pollution degree 3, 2 and 1 for use in earthed systems:

16A 250V 400V 4kV 3



## IEC 61140 Explained

### IEC 61140

On a daily basis, we are using many electrical appliances, some are grounded, and some are not. The levels of grounding protection are clearly defined by the International Electrotechnical Commission standard IEC 61140, a standard that has an influence on our connectors and how they should be used; our customers therefore need to pay particular attention to the three categories defined within this standard to ensure compatibility with their system. Everything explained hereafter is valid for connectors not intended to interrupt current.

#### Class I:

Devices which belong to this category have their chassis grounded via the ground wire (green/yellow in Europe, green in the US, Canada and Japan). A fault in the appliance might cause a live conductor to energize the casing. In this case, the current flows to the ground conductor and the circuit interrupter will cut off the power supply. In case of the UTS series, it means the envelope (coupling ring, backshell and housing) may become live, therefore, care needs to be taken to attach the connector to the ground. This is usually done via the ground conductor using a splice between the ground contact and the housing.

#### Class II:

Products in this category have reinforced insulation, meaning that the casing does not need to be connected to ground. In this case, the possibility of electric shock has been removed. Most of the time, reinforced insulation means double insulation, i.e. the second layer will take over the first one in case the first one fails. The UTS series is not designed to comply with this standard, so we cannot recommend it for this product category.

Note: UL 1310 also defines a class II device, but in that case this is just to set the upper limit of use, like a wall charger for our cell phone.

#### Class III:

In this category, electrical appliances are fed by a low voltage source (<48VAC or < 120VDC). In normal conditions live conductors can be accessible without any risk for the end user. No particular attention needs to be taken in regards to UTS series when it comes to a class III device.

#### Conclusion:

UTS series can be used in class I and class III environments, but each category affects the product performance. Throughout the catalog, current and voltage ratings have been given for class I devices keeping in mind the ground conductor needs to be attached according to recommended wiring instructions.

Note: Special applications like recreational vehicles are not under the scope of the IEC 61140.

## What is NEMA Rating ?

- NEMA ratings vs IP ratings

Whereas IP ratings only consider protection against ingress of foreign bodies (first digit) and ingress of water (second digit), NEMA ratings consider these but also verify protection from external ice, corrosive materials, oil immersion, etc.

The correlation between NEMA & IP being limited only to dust and water, we can state that a NEMA type is equivalent to an IP rating but it is not possible to say the contrary.

Below a list of some NEMA standards:

Enclosure rating	IP20	IP22	IP55	IP64	IP65	IP66	IP67	IP68
Type 1	•							
Type 3				•				
Type 3R		•						
Type 3S				•				
Type 4						•		
Type 4X						•		
Type 6							•	
Type 6P								•
Type 12			•					
Type 13					•			

• indicates compliance



Type 6 rating can be either Type 6 or Type 6P - please see below:

6	IP67	Enclosures constructed for either indoor or outdoor use to provide a degree of protection to personnel against incidental contact with the enclosed equipment, falling dirt, hose-directed water, the entry of water during <b>occasional temporary</b> submersion at a limited depth and damage from external ice formation.
6P	IP68	Enclosures constructed for either indoor or outdoor use to provide a degree of protection to personnel against incidental contact with the enclosed equipment, falling dirt, hose-directed water, the entry of water <b>during prolonged</b> submersion at a limited depth and damage from external ice formation.

## Ethernet for the Layman

In order to explain basic Ethernet theory, we can use a functional comparison to a busy city with highways, buildings and cars. To illustrate this, the table below provides correlation between the different components/pieces/links that encompass Ethernet network connectivity, and the larger scale infrastructure of a metropolitan city.

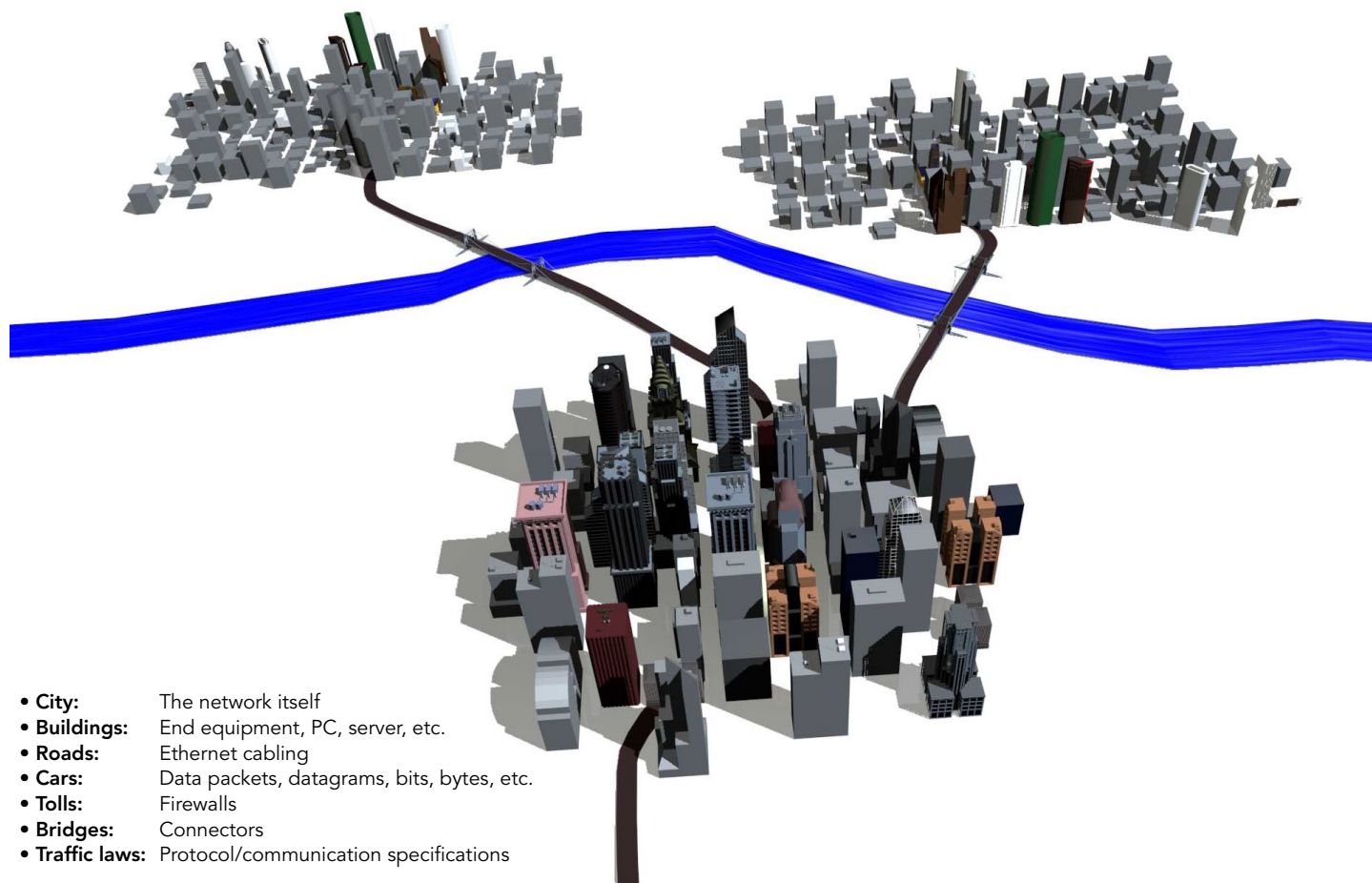

### Ethernet Basics

Ethernet is a widely used communications protocol that is used to transmit data packets (datagrams) between network devices. Imagine a highway in a large metropolitan area six lanes wide at rush hour. The vehicles on the highway need rules to follow so that they get to their destination without crashing into each other. In an Ethernet network link, there could be 100 million bits of information transmitted in one second. In the Ethernet standard, there exist rules to govern packet structure, transmission requirements, error correction, communication with end equipment, etc.

### Examining the differences between 100Mhz, 100 Base TX, Cat5e/Cat6. What does it all mean?

When discussing connectors and Ethernet, there are a few key details to be aware of:

- 100Mhz is a measurement of Frequency for the signal
  - Comparable to the Speed Limit of a highway
- 100BaseTX (or Fast Ethernet) is an Ethernet link standard and identifies available link bandwidth. The bandwidth is measured in units of MBits/S (megabits per second)
  - Comparable to the number of cars that pass a point in one second
- Cat5e/Cat6 are an EIA/TIA standard for performance and physical characteristics for cables and connectors
  - Comparable to performance specifications of the car and highway.

In connectors and cables, Fast Ethernet uses 2 pairs. One for transmit and one for receive. This way data traffic can flow in both directions simultaneously.

## Ethernet for the Layman (Continued)

### Souriau offering:

Standard solutions.

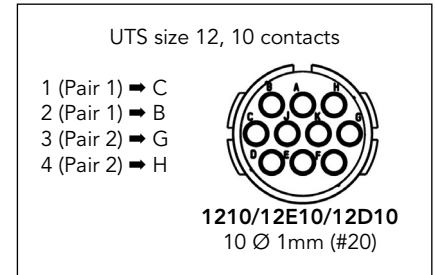
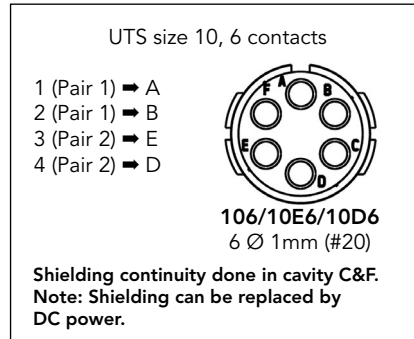
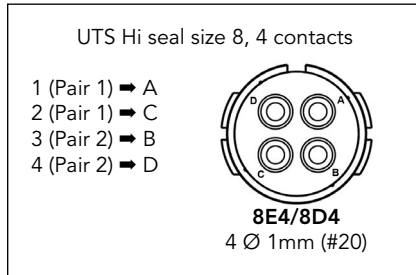

### What about using coax contacts ?

Ethernet twisted pairs carry a symmetrical (balanced) signal. Once terminated into a coax contact, the inner core will be protected by a shield - but not the outer contact. Because of EMI issues, the signal will no longer be balanced. Conclusion - it does not work and is not recommended.

### What about using Quadrax contacts ?

The Quadrax contact is used in railway applications because of the use of quad cable. In this specific market, the standard Ethernet twisted pairs wires cannot be offered, they are too thin and often solid (not stranded).

In the rest of industry, UTP (Unshielded Twisted Pairs) cables are widely used. The Quadrax contact is not designed to terminate them. And thus, are not advised for industrial applications.

### Conclusion

To carry 100Mb/s data signal, 100BaseTX or Fast Ethernet recommends the use of Cat5e connectors as well as Cat5e cable with the support of a 100MHz signal. Nevertheless, a 100Mb/s signal can be transmitted in certain conditions (short distance, only one connector, lower frequency but a different code) thru many other connection materials - not necessarily Cat5e rated.



# UTS SERIES

# Appendices

■ #16 Coaxial Contacts/Cabling Notices .....	200
■ Glossary of Terms .....	207
■ Discrimination/Keying Methods .....	208
■ Part number Index .....	209

## #16 Coaxial Contacts

### Coaxial Cable - Contact Monocrimp and Multipiece

Cable type	Impedance	Contact type	Ø over jacket		Ø over dielectric		Inner cond size Ext. Ø mm	Ø outer braid		Male contact kit for coaxial cable	Female contact kit for coaxial cable
			inch	mm	inch	mm		inch	mm		
RG161/U	75	Multi piece	0.09"	2.29	0.057"	1.45	-	-	-	RMDXK10D28	RCDXK1D28
RG179A/U	75		0.105"	2.67	0.063"	1.6	0.3	0.084"	2.13 max		
RG179B/U	75		0.105"	2.67	0.063"	1.6	0.3	0.084"	2.13 max		
RG187/U	75		0.11"	2.79 max	0.06"	1.52	0.3	-	-		
RG188/U	50		0.11"	2.79 max	0.06"	1.52	0.51	0.078"	1.98 max		
RG174/U	50		0.11"	2.92	0.06"	1.52	0.48	0.088"	2.24 max		
AMPHENOL 21-598	50		0.105"	2.67	0.06"	1.52	0.48	-	-		
RG196/U	50		0.08"	2.03 max	0.034"	0.086	0.3	-	-		
RG178A/U	50		0.075"	1.91	0.034"	0.86	0.3	0.054"	1.37 max		
RG/188A/U	50	Mono crimp	0.110"	2.79	0.06"	1.52	0.51	0.078"	1.98 max	RMDX6036D28	RCDX6036D28
KX21TVT (europe) RG178 B/U	50		0.075"	1.91	0.034"	0.86	0.3	0.054"	1.37 max	RMDX6034D28	RCDX6034D28
RG178 / BU	50		0.075"	1.91	0.034"	0.86	0.3	0.054"	1.37 max	RMDX6050D28	RCDX6016D28
RG174/U	50		0.115"	2.92	0.06"	1.52	0.48	0.088"	2.24 max	RMDX6032D28	RCDX6032D28
RG188A/U	50		0.11"	2.79	0.06"	1.52	0.51	0.078"	1.98 max	RMDX6036D28	RCDX6036D28
RG316/U	50		0.107"	2.72	0.06"	1.52	0.51	0.078"	2.05 max	RMDX6036D28	RCDX6036D28
raychem 5024A3111	50		0.12"	3.05	0.083"	2.11	0.64	0.097"	2.46	RMDX6052D28	RCDX6052D28
raychem 5026e1614	50		0.083"	2.11	0.05"	1.27	0.48	0.067"	1.7	RMDX6036D28	RCDX6036D28
surprenant pn 8134	-		Multi piece	0.1"	2.54	0.058"	1.47	0.3	-	-	RMDXK10D28
PRD PN 247AS-C1123-001	-	Mono crimp	0.103"	2.62	0.06"	1.52	0.51	0.078"	1.98	RMDX6018D28	RCDX6018D28
PRD PN 247AS-C1251	-		0.092"	2.34	0.05"	1.27	0.64	0.067"	1.7	RMDX6018D28	RCDX6018D28
JUDD C15013010902	-		0.087"	2.13	0.05"	1.27	0.48	0.066"	1.67	RMDX6036D28	RCDX6036D28
CDC PIN22939200	-		0.09"	2.29	0.048"	1.22	0.3	0.064"	1.63	RMDX6046D28	RCDX6016D28
CDC PIN22939200	-		0.09"	2.29	0.048"	1.22	0.3	0.064"	1.63	RMDX6050D28	RCDX6016D28
CDC PIN245670000	-		0.104"	2.64	0.067"	1.7	0.3	0.083"	2.11	RMDX6050D28	RCDX6016D28
ampex	-		0.114"	2.9	0.075"	1.91	0.38	0.09"	1.29	RMDX6032D28	RCDX6032D28
TI PN 920580	-		0.7"	1.78	0.038"	0.96	0.48	0.054v	1.37	RMDX6024D28	RCDX6024D28
Honeywell PN 58000062	-		0.12"	3.05	0.077"	1.96	0.41 solid	0.096"	2.44	RMDX6026D28	RCDX6026D28
-	-		0.104"	2.64	0.067"	1.7	0.3	-	2.11	RMDX6050D28	-
-	-		0.09"	2.29	0.048"	1.22	0.3	-	1.63	RMDX6050D28	-
-	-		0.114"	2.9	0.075"	1.91	0.38	-	1.29	RMDX6032D28	RCDX6032D28
-	-		0.07"	1.78	0.038"	0.96	0.48	-	1.37	RMDX6024D28	RCDX6024D28
-	-		0.12"	3.05	0.077"	1.96	0.41	-	2.44	RMDX6026D28	RCDX6026D28



**Twisted Cable - Contact Monocrimp and Multipiece**

Cable type	Contact type	Inner AWG cond	Ø over jacket (single wire)		Inner cond size		Ø outer braid		Male contact kit for coaxial cable	Female contact kit for coaxial cable
			inch	mm	Stranded definition	Ext. Ø mm	inch	mm		
2#24 stranded MIL-W-16878 type B	Multi piece	24	0.049"	1.24 max	7/.008	-	-	-	RMDXK10D28	RCDXK1D28
2 #24 solid MIL-W-76 type LW		24	0.047"	1.12 max	1/.0201	-	-	-	RMDXK10D28	RCDXK1D28
2 #26 stranded MIL-W-76 type LW or MIL-W-16878 type B&E		26	0.043"	1.09 max	7/.0063	0.16	-	-	RMDXK10D28	RCDXK1D28
2 #28 solid MIL-W-81822/3		28	0.028"	0.71 max	-	-	-	-	RMDXK10D28	RCDXK1D28
Twisted pair 1/.201 solid MIL-W-76 type LW or MIL-W-16878		26	0.044"	1.12 max	1/.0201	0.511	-	-	RMDXK10D28	RCDXK1D28
Twisted pair solid MIL-W-81822/3		28	0.028"	0.71 max	1/.0126	0.32	-	-	RMDXK10D28	RCDXK1D28
#28 7/.0036 per Hitachi spec ec-711 (13-2820)	Mono crimp	-	0.046"	1.17	7/.0036	-	-	-	RMDX6031D28 + YORX090	RCDX6031D28 + YORX090
20218201		-	0.028"	0.71	-	-	-	-	RMDX6031D28 + YORX090	RCDX6031D28 + YORX090
#30 solid		-	0.025"	0.64	-	-	-	-	RMDX6015D28 + YORX090	RCDX6015D28 + YORX090
#26 7/.0063		26	0.028"	0.71	7/.063	0.16	-	-	RMDX6031D28 + YORX090	RCDX6031D28 + YORX090
#26 19/.004		26	0.049"	1.24	19/.004	-	-	-	RMDX6019D28 + YORX090	RCDX6019D28 + YORX090
#24 7/.008		24	0.049"	1.24	7/.008	-	-	-	RMDX6019D28 + YORX090	RCDX6019D28 + YORX090
#24 19/.005		24	0.057"	1.45	19/.005	-	-	-	RMDX6019D28 + YORX090	RCDX6019D28 + YORX090
-		26	-	1.25	-	-	-	19x0.1	RMDX6019D28 + YORX090	RCDX6019D28 + YORX090
-		24	-	1.25	-	-	-	7x0.2	RMDX6019D28 + YORX090	RCDX6019D28 + YORX090
-		24	-	1.45	-	-	-	19x0.13	RMDX6019D28 + YORX090	RCDX6019D28 + YORX090
-		26	-	0.7	-	-	-	7x0.16	RMDX6031D28 + YORX090	RCDX6031D28 + YORX090

# #16 Coaxial Contacts (Continued)

## Twisted Pair Cable Multipiece Contact Cabling

Cable reference	Contact type	Male contact	Female contact	Crimp tool	Die set	Stop bushing	Cable strip length			Inner conductor crimp		Braid crimp	
							A	B	C	g dim	t dim	g dim	t dim
2#24 stranded mil w 16878 type B	Multi piece	RMDXK10D28	RCDXK1D28	M10S1J	-	-				See assembly notice			
2 #24 solid mil-w-76 type LW													
2 #26 stranded mil w 76 type LW or mil w16878 type B & E													
2 #28 solid mil-w-81822/3													
twisted pair 1/.201 solid mil w 76 type LW or mil w 16878													
twisted pair solid mil w 81822/3													

### Female contact

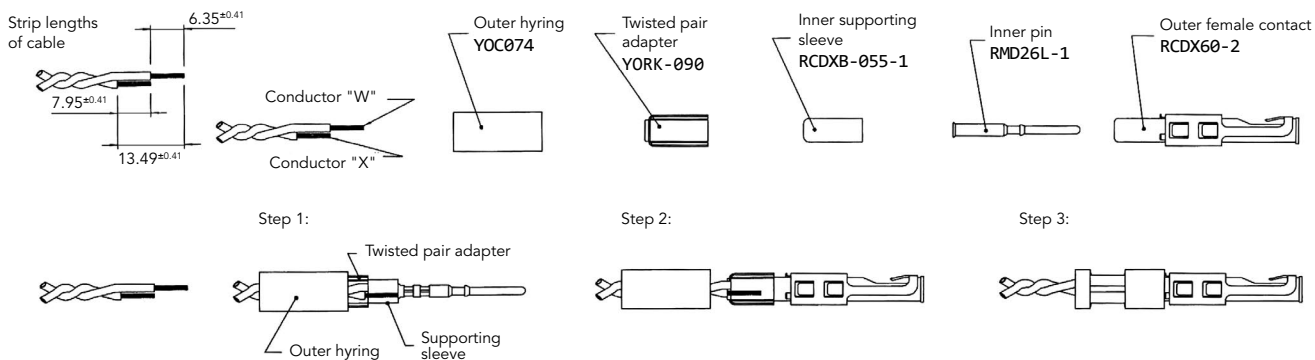

### Male contact

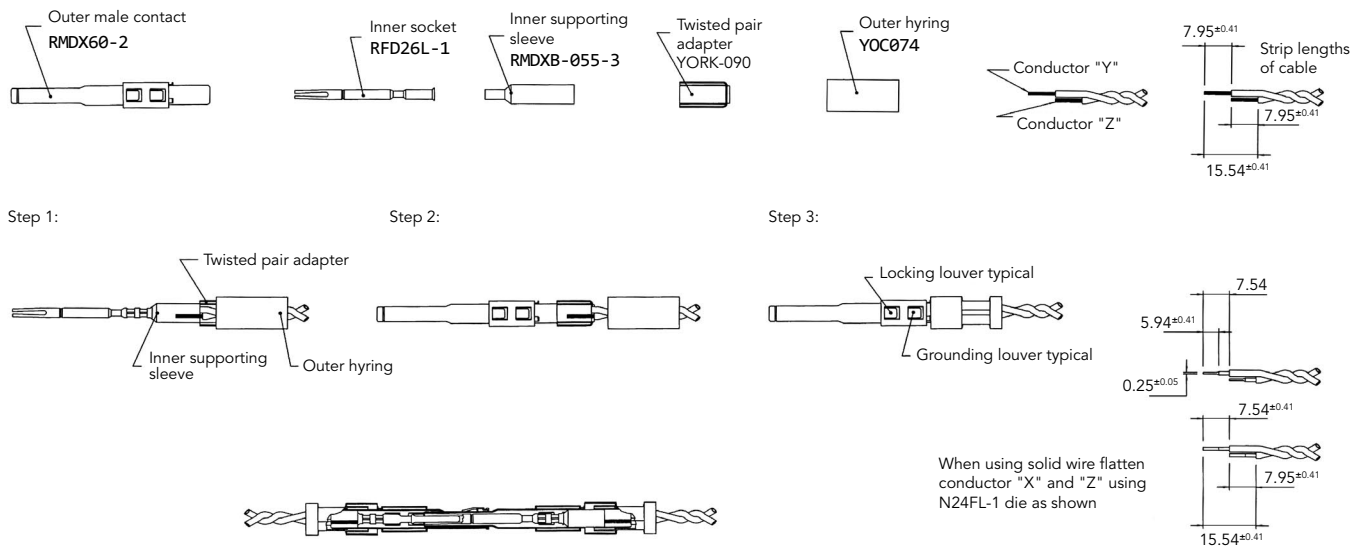

Note : all dimensions are in mm

### Twisted Pair Cable Monocrimp Contact Cabling

Cable reference	Contact type	Male contact	Female contact	Crimp tool	Die set	Stop bushing	Cable strip length			Inner conductor crimp		Braid crimp	
							A	B	C	g dim	t dim	g dim	t dim
#28 7/.0036 per Hitachi spec ec-711 (13-2820)	Mono crimp	RMDX6031D28 + YORX090	RCDX6031D28 + YORX090	M10S1J	S80	SL105	4.7	6.1	4.32	1.30 to 1.12	1.4 to 1.22	2.97 to 2.84	3.07 to 2.9
20218204							3.94	6.1	3.16	1.30 to 1.17	1.4 to 1.22	2.97 to 2.84	3.07 to 2.79
#30 solid							4.7	6.1	4.06	1.22 to 1.12	1.35 to 1.22	2.97 to 2.84	3.12 to 2.95
#26 7/.0063							4.7	6.1	4.06	1.30 to 1.17	1.4 to 1.22	2.97 to 2.84	3.07 to 2.9
#26 19/.004							4.7	6.1	4.06	1.22 to 1.17	1.35 to 1.22	2.84 to 2.79	3.12 to 2.97
#24 7/.008							4.7	6.1	4.06	1.22 to 1.17	1.35 to 1.22	2.84 to 2.79	3.12 to 2.97
#24 19/.005							4.7	6.1	4.06	1.22 to 1.17	1.35 to 1.22	2.84 to 2.79	3.12 to 2.97
AWG26 (19x0.1)							M10S68 crimping kit	4.7	6	4			
AWG24 (7x0.2)													
AWG24 (19x0.13)													
AWG26 (7x0.16)													

- Select appropriate monocrimp coax twisted pair contact and cable combination.
- Select appropriate crimp tooling (hand tool, S-die set, stop bushing).
- Strip the twisted pair cable to the designated wire strip lengths.
- Insert the stripped cable into the contact. One cable is to be inserted into the inside diameter of hyring, and pushed forward into the inner contact. The second cable is to be inserted between the outside diameter of hyring and the inside diameter of the outer contact body.
- Crimp the contact.

Cable strip length

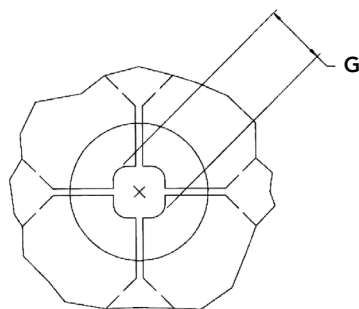
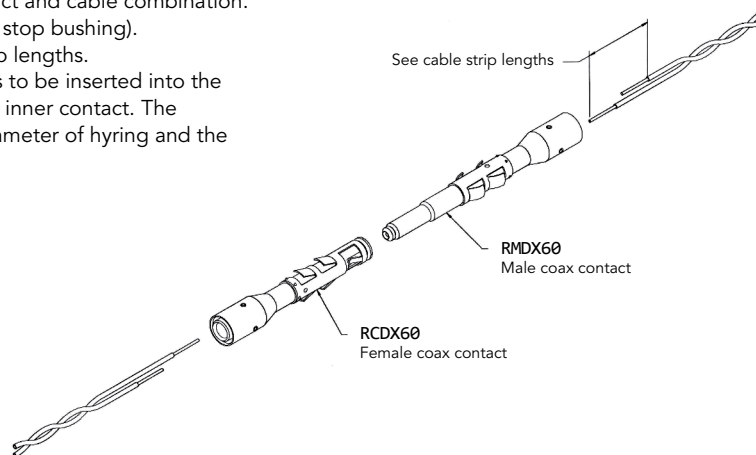
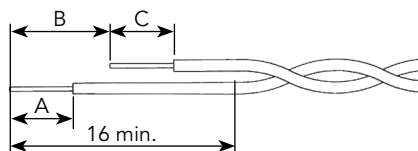

Braid crimp (G) to be measured with die set fully closed

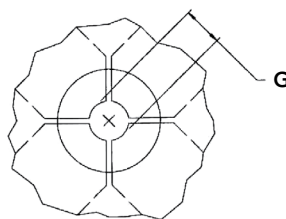

Inner conductor crimp (G) to be measured with die set fully closed

Note : all dimensions are in mm

# #16 Coaxial Contacts (Continued)

## Multipiece Male Contact with Coax Cable

Cable reference	Contact	Hyring complementary compoments	Outer contact crimp tool		Inner contact crimp tool		Cable strip length		
			Crimp tool M10S1J		Crimp tool M10S1J				
			Die set	Stop bushing	Die set	Stop bushing	A	B	C
RG161U	Male: RMDXK10D28	YOC074	S221	SL471	S23D2	SL46D2	4.37	7.95	15.88
RG179							4.37	7.95	15.88
RG187U							4.37	7.95	15.88
RG188/U		YOC074 + RMDXB0553			S26D2		4.37	7.95	15.88
RG174/U							4.37	7.95	15.88
RG178A/U		YOC074			S23D2		7.54	9.12	17.53
RG196U							7.54	9.12	17.53
AMPHENOL 21-598		YOC074			-		4.37	7.95	15.88
surprenant pn 8134							4.37	7.95	15.88

Multipiece kit details

RMDXK10D28 includes	RMDX602D28	Outer contact
	RFD26L1D28	Inner contact
	YOC074	Outer hyring
	RMDXB0553	Inner supporting sleeve

Cable strip length

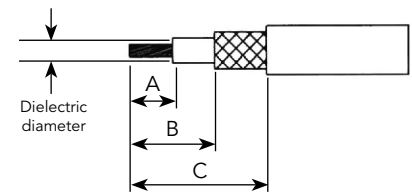

### Contact assembly with dielectric diameter over 1.4mm - without inner supporting sleeve

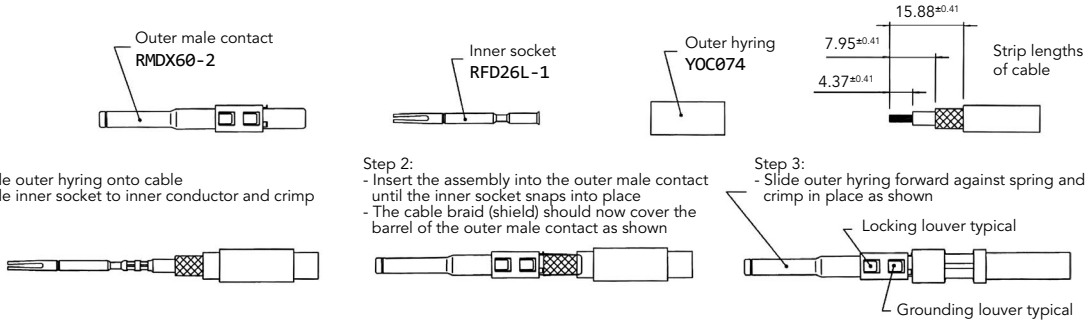

### Contact assembly with dielectric diameter under 1.4mm - with inner supporting sleeve

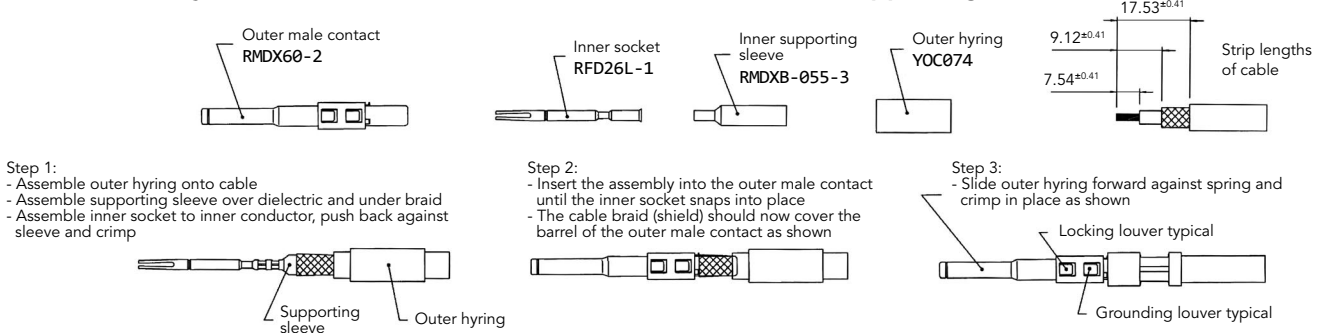

Note : all dimensions are in mm

### Multipiece Female Contact with Coax Cable

Cable reference	Contact	Hyring complementary compoments	Outer contact crimp tool		Inner contact crimp tool		Cable strip length		
			Crimp tool M10S1J		Crimp tool M10S1J		A	B	C
			Die set	Stop bushing	Die set	Stop bushing			
RG161U	Female: RCDXK1D28	YOC074	S221	SL471	S23D2	SL46D2	4.37	-	11.13
RG179							4.37		11.13
RG187U							4.37		11.13
RG188/U							4.37		11.13
RG174/U		YOC074 + RMDXB0553			4.37		11.13		
RG178A/U					6.35		11.13		
RG196U					6.35		11.13		
AMPHENOL 21-598		YOC074			-		4.37		11.13
surprenant pn 8134					-		4.37		11.13

Multipiece kit details

RCDXK1D28 includes	Part	Description
	RCDX602D28	Outer contact
	RMD26L1D28	Inner contact
	YOC074	Outer hyring
	RCDXB0553	Inner supporting sleeve

Cable strip length

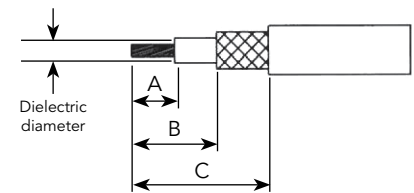

Contact assembly with dielectric diameter over 1.4mm - without inner supporting sleeve

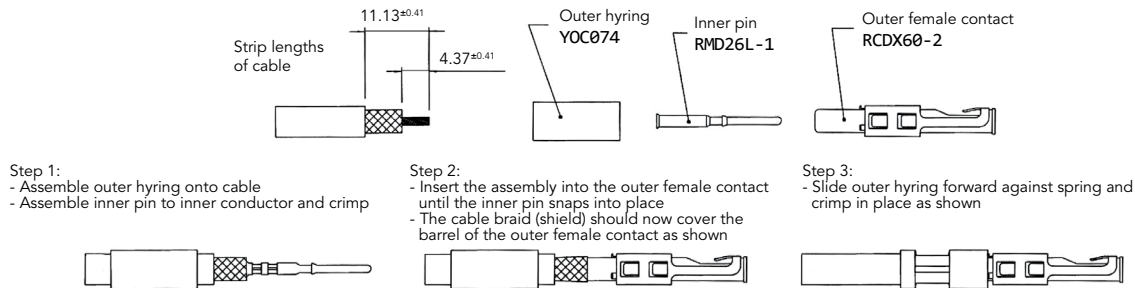

Contact assembly with dielectric diameter under 1.4mm - with inner supporting sleeve

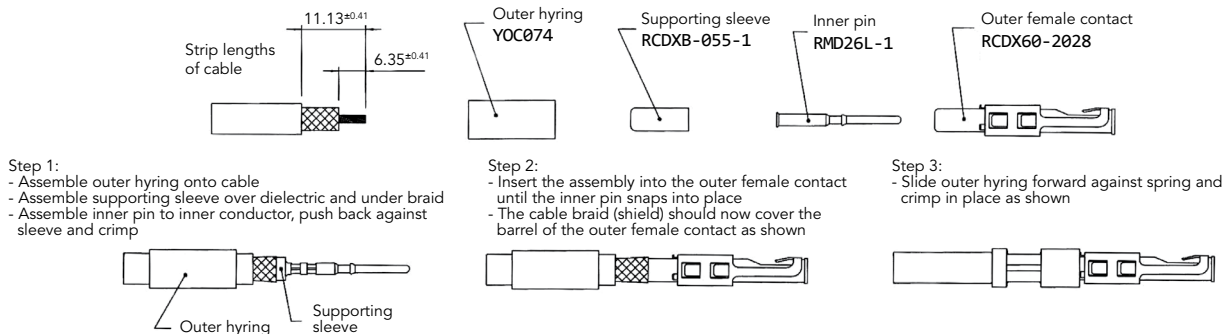

Note : all dimensions are in mm

## #16 Coaxial Contacts (Continued)

### Coax Cable with Monocrimp Contact Cabling

Cable reference	Male contact	Female contact	Crimp tool	Die set	Stop bushing	Cable strip length			Inner conductor crimp		Braid crimp		
						A	B	C	g dim	t dim	g dim	t dim	
CDC PIN22939200	RMDX6046D28	RCDX6016D28	M1051J	S80	SL105	4.19	5.97	8.51	1.30/1.17	1.40/1.22	2.77/2.64	3.02/2.84	
CDC PIN22939200	RMDX6046D28	RCDX6016D28		S87	SL105	5.08	6.35	8.89	1.30/1.17	1.40/1.22	2.77/2.64	3.02/2.84	
CDC PIN245670000	RMDX6050D28	RCDX6016D28		S80	SL105	5.08	6.35	8.89	1.30/1.17	1.40/1.22	2.97/2.84	3.12/2.95	
KX21TVT (europe) RG178 B/U	RMDX6034D28	RCDX6034D28		S82	SL105	5.08	6.35	8.89	1.30/1.17	1.32/1.17	2.84/2.74	3.07/2.9	
RG178 / BU	RMDX6050D28	RCDX6016D28		S87	SL105	5.08	6.35	8.89	1.30/1.17	1.40/1.22	2.77/2.64	3.02/2.84	
ampex	RMDX6032D28	RCDX6032D28		S80	SL105	5.08	6.35	11.68	1.30/1.17	1.40/1.22	2.97/2.84	3.12/2.95	
TI PN 920580	RMDX6024D28	RCDX6024D28		S82	SL105	5.08	6.35	8.89	1.35/1.19	1.42/1.27	2.87/2.74	3.07/2.9	
RG174/U	RMDX6032D28	RCDX6032D28		S80	SL105	5.08	6.35	11.68	1.30/1.17	1.40/1.22	2.97/2.84	3.12/2.95	
Honeywell PN 58000062	RMDX6026D28	RCDX6026D28		S82	SL105	5.08	6.35	8.89	1.35/1.19	1.42/1.27	2.87/2.74	3.07/2.9	
RG188A/U	RMDX6036D28	RCDX6036D28		S80	SL105	5.08	6.35	11.68	1.30/1.17	1.40/1.22	2.97/2.84	3.12/2.95	
RG316/U	RMDX6036D28	RCDX6036D28		S80	SL105	5.08	6.35	11.68	1.30/1.17	1.40/1.22	2.97/2.84	3.12/2.95	
PRD PN 247AS-C1123-001	RMDX6018D28	RCDX6018D28		M105G8 TOOL DIE SET STOP BUSHING M1051J TOOL			5.08	6.35	8.89	1.22/1.17	1.35/1.22	2.92/2.79	3.12/2.97
PRD PN 247AS-C1251	RMDX6018D28	RCDX6018D28					5.08	6.35	8.89	1.22/1.17	1.35/1.22	2.92/2.79	3.12/2.97
raychem 5024A3111	RMDX6052D28	RCDX6052D28		S88	SL105	5.08	6.35	11.68	1.37/1.27	1.45/1.32	2.92/2.79		
raychem 5026e1614	RMDX6036D28	RCDX6036D28		M105G8 TOOL DIE SET STOP BUSHING M1051J TOOL			5.08	6.35	8.89	1.22/1.17	1.35/1.22	2.92/2.79	3.12/2.97
JUDD C15013010902	RMDX6036D28	RCDX6036D28					5.08	6.35	8.89	1.22/1.17	1.35/1.22	2.92/2.79	3.12/2.97
inner cond. #30, braid diam 2.64	RMDX6050D28	-		S80	SL105	5.1	6.35	8.9	-	-	-	-	
inner cond. #30, braid diam 2.29	RMDX6050D28	-		S87	SL105	4.2	6.35	8.5	-	-	-	-	
inner cond. #28, braid diam 2.9	RMDX6032D28	RCDX6032D28		S80	SL105	5.1	6.35	11.7	-	-	-	-	
inner cond. #26, braid diam 1.78	RMDX6024D28	RCDX6024D28		S82	SL105	5.1	6.35	8.9	-	-	-	-	
inner cond. #26, braid diam 3.05	RMDX6026D28	RCDX6026D28	S82	SL105	5.1	6.35	8.9	-	-	-	-		

- Select appropriate cable and contact combination.
- Select appropriate crimp tooling (hand tool, S-die set, stop bushing).
- Strip coax cable to the designated wire strip lengths.
- Insert the stripped coax into the rear of the contact.
- Crimp the contact.

Cable strip length

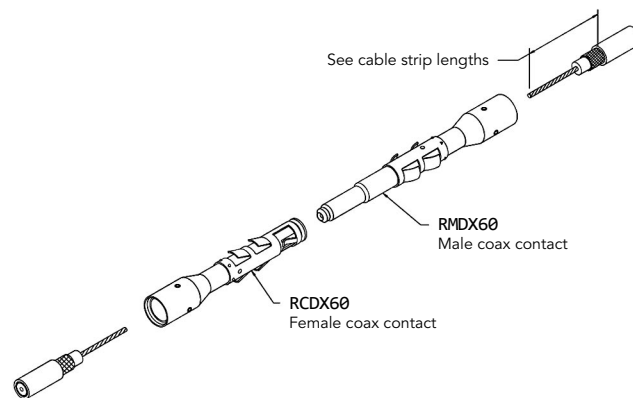
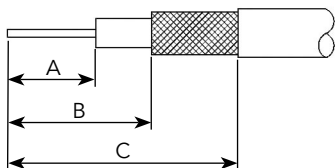

## Glossary of Terms

- **Clearance**

Per the IEC 60664-1 it is the shortest distance between two conductive parts even over the air.

- **Creepage distance**

Per the IEC 60664-1 it represents the shortest distance along the surface of the insulating material between two conductive parts.

- **Working voltage**

Per the IEC 60664-1 it is the highest r.m.s. value of A.C. or D.C. voltage across any particular insulation which can occur when the equipment is supplied at rated voltage.

- **Rated impulse voltage**

Impulse withstands voltage value assigned by the manufacturer to the equipment or to a part of it characterizing the specified withstand capability of its insulation against transient overvoltage.

- **Working current**

It is the maximum continuous and not interrupted current able to be carried by all contacts without exceeding the maximum temperature of the insulating material.

- **Transient voltage**

Extract from the IEC 60664-1: Short duration overvoltage of a few millisecond or less, oscillatory or non-oscillatory, usually highly damped.

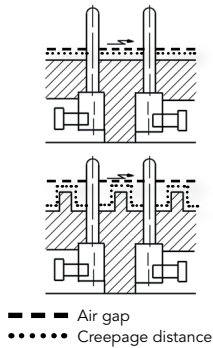

- **CTI (Comparative Tracking Index)**

The CTI value is commonly used to characterise the electrical breakdown properties of an insulating material. It allows users to know the tendency to create creepage paths. This value represents the maximum voltage after 50 drops of ammonium chloride solution without any breakdown.

- **RTI (Relative temperature Index):**

Extract from ULs website:

Maximum service temperature for a material, where a class of critical property will not be unacceptably compromised through chemical thermal degradation, over the reasonable life of an electrical product, relative to a reference material having a confirmed, acceptable corresponding performance defined RTI.

- **RTI Elec:** Electrical RTI, associated with critical electrical insulating properties.

- **RTI Mech Imp:** Mechanical Impact RTI, associated with critical impact resistance, resilience and flexibility properties.

- **RTI Mech Str:** Mechanical Strength (Mechanical without Impact) RTI, associated with critical mechanical strength where impact resistance, resilience and flexibility are not essential.

## Discrimination/Keying Methods

In applications where similar connectors are used next to each other, mismatching can cause disturbances, system failure or even danger to operating personnel.

To eliminate mismatching, some Trim Trio® connectors are offered with discrimination keys to avoid interconnection system errors. In addition, the connector insert can also be rotated inside the shell to create custom keying options.

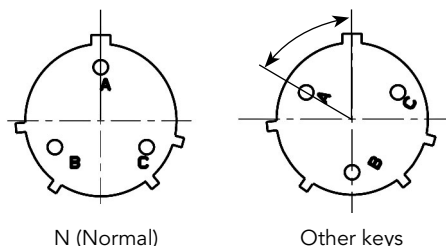

Note: Insert rotated in body  
(viewed from front face of male insert)

Connectors with rotated inserts can be ordered by adding the suffix W, X, Y or Z to the standard part number.

e.g. **UTS6JC104S** (N key) → **UTS6JC104SW** (W key)

Consult us for overmoulded harnesses.

Shell size	Layout	Discrimination keys degrees			
		W	X	Y	Z
8	8E2/8D2	58°	122°	-	-
	8E3/8D3 8E3A/ 8D3A 8E98/8D98	60°	210°	-	-
	8E4/8D4	45°	-	-	-
	8E33/8D33	90°	-	-	-
10	102W2/103	-	-	-	-
	104	45°	-	-	-
	103W3	-	-	-	-
	106 10E6/10D6	90°	-	-	-
	10E7/10D7	90°	-	-	-
12	10E98/ 10D98	90°	180°	240°	270°
	12E2/12D2	-	-	-	-
	12E3/12D3	-	-	180°	-
	124 12E4/12D4	-	-	-	-
	128	26°	-	-	-
	12E8/12D8	90°	112°	203°	292°
	1210 12E10/12D10	60°	155°	270°	295°
12E14/12D14	45°	-	-	-	
14	14E5/14D5	40°	92°	184°	273°
	142G1	-	-	-	-
	147 14E7/14D7	-	-	-	-
	148	-	-	-	-
	1412	60°	-	-	-
	1492	49°	71°	145°	-
	14E12/14D12	43°	90°	-	-
	14E15/14D15	17°	110°	155°	234°
	14E18/14D18	15°	90°	180°	270°
	1419	30°	165°	315°	-
	14E19/14D19	30°	165°	315°	-
18	183G1	-	-	-	-
	18X2M3	-	-	-	-
	1823	-	158°	-	270°
	1832 18E32/18D32	85°	138°	222°	265°

### SMSPK0 (only for UTS layouts using #16 contacts)

When one of these dummy contacts is used, the UTS connector will only mate with a connector which has a vacant cavity at the corresponding position.

The material used is polyamide 6.6.





## Part Number Index

### Connectors

UTS0104P.....	P. 68	UTS014D12P.....	P. 120	UTS1GJC1492P.....	P. 124
UTS0104S.....	P. 68	UTS014D12S.....	P. 120	UTS1GN104P.....	P. 68
UTS010D6P.....	P. 84	UTS014D15P.....	P. 132	UTS1GN128P.....	P. 100
UTS010D6S.....	P. 84	UTS014D15S.....	P. 132	UTS1GN1412P.....	P. 116
UTS710D6P.....	P. 84	UTS014D18P.....	P. 136	UTS1GN147P.....	P. 92
UTS710D6P32.....	P. 84	UTS014D18S.....	P. 136	UTS1GN1492P.....	P. 124
UTS710D6S.....	P. 84	UTS014D19P.....	P. 140	UTS1JJC102W2P.....	P. 64
UTS710D6S32.....	P. 84	UTS014D19S.....	P. 140	UTS1JJC102W2S.....	P. 64
UTS010D98P.....	P. 88	UTS014D5P.....	P. 72	UTS1JJC103P.....	P. 28
UTS010D98S.....	P. 88	UTS014D5S.....	P. 72	UTS1JJC103S.....	P. 28
UTS010E6P.....	P. 84	UTS014E12P.....	P. 120	UTS1JJC103W3P.....	P. 80
UTS010E6S.....	P. 84	UTS014E12S.....	P. 120	UTS1JJC103W3S.....	P. 80
UTS010E7P.....	P. 96	UTS014E15P.....	P. 132	UTS1JJC104P.....	P. 68
UTS010E7S.....	P. 96	UTS014E15S.....	P. 132	UTS1JJC104S.....	P. 68
UTS010E98P.....	P. 88	UTS014E18P.....	P. 136	UTS1JJC106P.....	P. 84
UTS010E98S.....	P. 88	UTS014E18S.....	P. 136	UTS1JJC106S.....	P. 84
UTS0124P.....	P. 52	UTS014E19P.....	P. 140	UTS1JJC1210P.....	P. 112
UTS0128P.....	P. 100	UTS014E19S.....	P. 140	UTS1JJC1210S.....	P. 112
UTS0128S.....	P. 100	UTS014E5P.....	P. 72	UTS1JJC124P.....	P. 52
UTS012D10P.....	P. 112	UTS014E5S.....	P. 72	UTS1JJC124PSCR.....	P. 52
UTS012D10S.....	P. 112	UTS014E7P.....	P. 92	UTS1JJC124S.....	P. 52
UTS012D14P.....	P. 128	UTS014E7S.....	P. 92	UTS1JJC128P.....	P. 100
UTS012D14S.....	P. 128	UTS01823P.....	P. 144	UTS1JJC128S.....	P. 100
UTS012D2P.....	P. 24	UTS01823S.....	P. 144	UTS1JJC1412P.....	P. 116
UTS012D2S.....	P. 24	UTS018E32P.....	P. 148	UTS1JJC1412S.....	P. 116
UTS012D3P.....	P. 48	UTS08D2P.....	P. 20	UTS1JJC1419P.....	P. 140
UTS012D3S.....	P. 48	UTS08D2S.....	P. 20	UTS1JJC1419S.....	P. 140
UTS012D4P.....	P. 52	UTS08D33P.....	P. 44	UTS1JJC142G1P.....	P. 32
UTS012D4S.....	P. 52	UTS08D33S.....	P. 44	UTS1JJC142G1S.....	P. 32
UTS012D8P.....	P. 104	UTS08D3AP.....	P. 40	UTS1JJC147P.....	P. 92
UTS012D8S.....	P. 104	UTS08D3AS.....	P. 40	UTS1JJC1492P.....	P. 124
UTS012E10P.....	P. 112	UTS08D3P.....	P. 36	UTS1JJC1492S.....	P. 124
UTS012E10S.....	P. 112	UTS08D3S.....	P. 36	UTS1JJC147PSCR.....	P. 92
UTS012E14P.....	P. 128	UTS08D4P.....	P. 60	UTS1JJC147S.....	P. 92
UTS012E14S.....	P. 128	UTS08D4S.....	P. 60	UTS1JJC148P.....	P. 108
UTS012E2P.....	P. 24	UTS08D98P.....	P. 40	UTS1JJC148S.....	P. 108
UTS012E2S.....	P. 24	UTS08D98S.....	P. 40	UTS1JJC1823P.....	P. 144
UTS012E3P.....	P. 48	UTS08E2P.....	P. 20	UTS1JJC1823S.....	P. 144
UTS012E3S.....	P. 48	UTS08E2S.....	P. 20	UTS1JJC1832P.....	P. 148
UTS012E4P.....	P. 52	UTS08E33P.....	P. 44	UTS1JJC1832S.....	P. 148
UTS012E4S.....	P. 52	UTS08E33S.....	P. 44	UTS1JJC18LCN.....	P. 152
UTS012E8P.....	P. 104	UTS08E3AP.....	P. 40	UTS1JJC18MPN.....	P. 156
UTS012E8S.....	P. 104	UTS08E3AS.....	P. 40	UTS6102W2P.....	P. 64
UTS01412P.....	P. 116	UTS08E3P.....	P. 36	UTS6102W2S.....	P. 64
UTS01412S.....	P. 116	UTS08E3S.....	P. 36	UTS6103P.....	P. 28
UTS0142G1P.....	P. 32	UTS08E4P.....	P. 60	UTS6103S.....	P. 28
UTS0147P.....	P. 92	UTS08E4S.....	P. 60	UTS6103W3P.....	P. 80
UTS0147S.....	P. 92	UTS08E98P.....	P. 40	UTS6103W3S.....	P. 80
UTS01492P.....	P. 124	UTS08E98S.....	P. 40	UTS6104P.....	P. 68
UTS01492S.....	P. 124	UTS1GJC104P.....	P. 68	UTS6104S.....	P. 68
UTS014D7P.....	P. 92	UTS1GJC128P.....	P. 100	UTS6106P.....	P. 84
UTS014D7S.....	P. 92	UTS1GJC1412P.....	P. 116	UTS6106S.....	P. 84
		UTS1GJC147P.....	P. 92	UTS610E6P.....	P. 84

Part Number Index (Continued)

UTS610E6S.....	P. 84	UTS68E2P.....	P. 20	UTS6JC12E3S.....	P. 48
UTS610E7P.....	P. 96	UTS68E2S.....	P. 20	UTS6JC12E4P.....	P. 52
UTS610E7S.....	P. 96	UTS68E33P.....	P. 44	UTS6JC12E4S.....	P. 52
UTS610E98P.....	P. 88	UTS68E33S.....	P. 44	UTS6JC12E8P.....	P. 104
UTS610E98S.....	P. 88	UTS68E3AP.....	P. 40	UTS6JC12E8S.....	P. 104
UTS61210P.....	P. 112	UTS68E3AS.....	P. 40	UTS6JC1412P.....	P. 116
UTS61210S.....	P. 112	UTS68E3P.....	P. 36	UTS6JC1412S.....	P. 116
UTS6124P.....	P. 52	UTS68E3S.....	P. 36	UTS6JC1419P.....	P. 140
UTS6124PSCR.....	P. 52	UTS68E4P.....	P. 60	UTS6JC1419S.....	P. 140
UTS6124SSCR.....	P. 52	UTS68E4S.....	P. 60	UTS6JC142G1P.....	P. 32
UTS6128P.....	P. 100	UTS68E98P.....	P. 40	UTS6JC142G1S.....	P. 32
UTS6128S.....	P. 100	UTS68E98S.....	P. 40	UTS6JC147P.....	P. 92
UTS612E10P.....	P. 112	UTS6GGJC104S.....	P. 68	UTS6JC147PSCR.....	P. 92
UTS612E10S.....	P. 112	UTS6GGJC128S.....	P. 100	UTS6JC147S.....	P. 92
UTS612E14P.....	P. 128	UTS6GGJC1412S.....	P. 116	UTS6JC147SSCR.....	P. 92
UTS612E14S.....	P. 128	UTS6GGJC147S.....	P. 92	UTS6JC1492P.....	P. 124
UTS612E2P.....	P. 24	UTS6GGJC1492S.....	P. 124	UTS6JC1492S.....	P. 124
UTS612E2S.....	P. 24	UTS6GN104S.....	P. 68	UTS6JC148P.....	P. 108
UTS612E3P.....	P. 48	UTS6GN128S.....	P. 100	UTS6JC148S.....	P. 108
UTS612E3S.....	P. 48	UTS6GN1412S.....	P. 116	UTS6JC14E12P.....	P. 120
UTS612E4P.....	P. 52	UTS6GN147S.....	P. 92	UTS6JC14E12S.....	P. 120
UTS612E4S.....	P. 52	UTS6GN1492S.....	P. 124	UTS6JC14E15P.....	P. 132
UTS612E8P.....	P. 104	UTS6JC102W2P.....	P. 64	UTS6JC14E15S.....	P. 132
UTS612E8S.....	P. 104	UTS6JC102W2S.....	P. 64	UTS6JC14E18P.....	P. 136
UTS61412P.....	P. 116	UTS6JC103P.....	P. 28	UTS6JC14E18S.....	P. 136
UTS61412S.....	P. 116	UTS6JC103S.....	P. 28	UTS6JC14E19P.....	P. 140
UTS61419P.....	P. 140	UTS6JC103W3P.....	P. 80	UTS6JC14E19S.....	P. 140
UTS61419S.....	P. 140	UTS6JC103W3S.....	P. 80	UTS6JC14E5P.....	P. 72
UTS6142G1P.....	P. 32	UTS6JC104P.....	P. 68	UTS6JC14E5S.....	P. 72
UTS6142G1S.....	P. 32	UTS6JC104S.....	P. 68	UTS6JC14E7P.....	P. 92
UTS6147P.....	P. 92	UTS6JC106P.....	P. 84	UTS6JC14E7S.....	P. 92
UTS6147S.....	P. 92	UTS6JC106S.....	P. 84	UTS6JC1823P.....	P. 144
UTS6148P.....	P. 108	UTS6JC10E6P.....	P. 84	UTS6JC1823S.....	P. 144
UTS6148S.....	P. 108	UTS6JC10E6S.....	P. 84	UTS6JC1832P.....	P. 148
UTS61492P.....	P. 124	UTS6JC10E7P.....	P. 96	UTS6JC1832S.....	P. 148
UTS61492S.....	P. 124	UTS6JC10E7S.....	P. 96	UTS6JC183G1P.....	P. 56
UTS614E12P.....	P. 120	UTS6JC10E98P.....	P. 88	UTS6JC18LCN.....	P. 152
UTS614E12S.....	P. 120	UTS6JC10E98S.....	P. 88	UTS6JC18MPN.....	P. 156
UTS614E15P.....	P. 132	UTS6JC1210P.....	P. 112	UTS6JC18X2M3P.....	P. 76
UTS614E15S.....	P. 132	UTS6JC1210S.....	P. 112	UTS6JC18X2M3S.....	P. 76
UTS614E18P.....	P. 136	UTS6JC124P.....	P. 52	UTS6JC8E2P.....	P. 20
UTS614E18S.....	P. 136	UTS6JC124PSCR.....	P. 52	UTS6JC8E2S.....	P. 20
UTS614E19P.....	P. 140	UTS6JC124S.....	P. 52	UTS6JC8E33P.....	P. 44
UTS614E19S.....	P. 140	UTS6JC124SSCR.....	P. 52	UTS6JC8E33S.....	P. 44
UTS614E5P.....	P. 72	UTS6JC128P.....	P. 100	UTS6JC8E3AP.....	P. 40
UTS614E5S.....	P. 72	UTS6JC128S.....	P. 100	UTS6JC8E3AS.....	P. 40
UTS61823P.....	P. 144	UTS6JC12E10P.....	P. 112	UTS6JC8E3P.....	P. 36
UTS61823S.....	P. 144	UTS6JC12E10S.....	P. 112	UTS6JC8E3S.....	P. 36
UTS61832P.....	P. 148	UTS6JC12E14P.....	P. 128	UTS6JC8E4P.....	P. 60
UTS61832S.....	P. 148	UTS6JC12E14S.....	P. 128	UTS6JC8E4S.....	P. 60
UTS6183G1P.....	P. 56	UTS6JC12E2P.....	P. 24	UTS6JC8E98P.....	P. 40
UTS618X2M3P.....	P. 76	UTS6JC12E2S.....	P. 24	UTS6JC8E98S.....	P. 40
UTS618X2M3S.....	P. 76	UTS6JC12E3P.....	P. 48	UTS7102W2P.....	P. 64

UTS7102W2S.....	P. 64	UTS712D4P32.....	P. 52	UTS714D19S.....	P. 140
UTS7103P.....	P. 28	UTS712D4S.....	P. 52	UTS714D19S32.....	P. 140
UTS7103S.....	P. 28	UTS712D4S32.....	P. 52	UTS714D5P.....	P. 72
UTS7103W3P.....	P. 80	UTS712D8P.....	P. 104	UTS714D5P32.....	P. 72
UTS7103W3S.....	P. 80	UTS712D8P32.....	P. 104	UTS714D5S.....	P. 72
UTS7104P.....	P. 68	UTS712D8S.....	P. 104	UTS714D5S32.....	P. 72
UTS7104S.....	P. 68	UTS712D8S32.....	P. 104	UTS714E12P.....	P. 120
UTS7106P.....	P. 84	UTS712E10P.....	P. 112	UTS714E12S.....	P. 120
UTS7106S.....	P. 84	UTS712E10S.....	P. 112	UTS714E15P.....	P. 132
UTS710D98P.....	P. 88	UTS712E14P.....	P. 128	UTS714E15S.....	P. 125
UTS710D98P32.....	P. 88	UTS712E14S.....	P. 128	UTS714E18P.....	P. 136
UTS710D98S.....	P. 88	UTS712E2P.....	P. 24	UTS714E18S.....	P. 136
UTS710D98S32.....	P. 88	UTS712E2S.....	P. 24	UTS714E19P.....	P. 140
UTS710E6P.....	P. 84	UTS712E3P.....	P. 48	UTS714E19S.....	P. 140
UTS710E6S.....	P. 84	UTS712E3S.....	P. 48	UTS714E5P.....	P. 72
UTS710E6PMM16.....	P. 84	UTS712E4P.....	P. 52	UTS714E5S.....	P. 72
UTS710E6SM16.....	P. 84	UTS712E4S.....	P. 52	UTS714E7P.....	P. 92
UTS710E7P.....	P. 96	UTS712E8P.....	P. 104	UTS714E7S.....	P. 92
UTS710E7S.....	P. 96	UTS712E8S.....	P. 104	UTS71823P.....	P. 144
UTS710E7PMM16.....	P. 96	UTS71412P.....	P. 116	UTS71823S.....	P. 144
UTS710E7SM16.....	P. 96	UTS71412S.....	P. 116	UTS71832P.....	P. 148
UTS710E98P.....	P. 88	UTS71419P.....	P. 140	UTS71832S.....	P. 148
UTS710E98S.....	P. 88	UTS71419S.....	P. 140	UTS7183G1SNPT.....	P. 56
UTS71210P.....	P. 112	UTS7142G1P.....	P. 32	UTS718LCN.....	P. 152
UTS71210S.....	P. 112	UTS7142G1S.....	P. 32	UTS718MPN.....	P. 156
UTS7124P.....	P. 52	UTS7142G1SNPT.....	P. 32	UTS718X2M3PNPT.....	P. 76
UTS7124PSCR.....	P. 52	UTS7147P.....	P. 92	UTS718X2M3SNPT.....	P. 76
UTS7124S.....	P. 52	UTS7147PSCR.....	P. 92	UTS78D2P.....	P. 20
UTS7124SSCR.....	P. 52	UTS7147PSEK9.....	P. 92	UTS78D2P32.....	P. 20
UTS7128P.....	P. 100	UTS7147S.....	P. 92	UTS78D2S.....	P. 20
UTS7128PM20.....	P. 100	UTS71492P.....	P. 124	UTS78D2S32.....	P. 20
UTS7128PM20NUT.....	P. 100	UTS71492S.....	P. 124	UTS78D33P.....	P. 44
UTS7128PSEK9.....	P. 100	UTS7148P.....	P. 108	UTS78D33P32.....	P. 44
UTS7128S.....	P. 100	UTS7148S.....	P. 108	UTS78D33S.....	P. 44
UTS7128SM20.....	P. 100	UTS7147SSCR.....	P. 92	UTS78D33S32.....	P. 44
UTS7128SM20NUT.....	P. 100	UTS714D7P.....	P. 92	UTS78D3AP.....	P. 40
UTS712D10P.....	P. 112	UTS714D7P32.....	P. 92	UTS78D3AP32.....	P. 40
UTS712D10P32.....	P. 112	UTS714D7S.....	P. 92	UTS78D3AS.....	P. 40
UTS712D10S.....	P. 112	UTS714D7S32.....	P. 92	UTS78D3AS32.....	P. 40
UTS712D10S32.....	P. 112	UTS714D12P.....	P. 120	UTS78D3P.....	P. 36
UTS712D14P.....	P. 128	UTS714D12P32.....	P. 120	UTS78D3P32.....	P. 36
UTS712D14P32.....	P. 128	UTS714D12S.....	P. 120	UTS78D3S.....	P. 36
UTS712D14S.....	P. 128	UTS714D12S32.....	P. 120	UTS78D3S32.....	P. 36
UTS712D14S32.....	P. 128	UTS714D15P.....	P. 132	UTS78D4P.....	P. 60
UTS712D2P.....	P. 24	UTS714D15P32.....	P. 132	UTS78D4P32.....	P. 60
UTS712D2P32.....	P. 24	UTS714D15S.....	P. 132	UTS78D4S.....	P. 60
UTS712D2S.....	P. 24	UTS714D15S32.....	P. 132	UTS78D4S32.....	P. 60
UTS712D2S32.....	P. 24	UTS714D18P.....	P. 136	UTS78D98P.....	P. 40
UTS712D3P.....	P. 48	UTS714D18P32.....	P. 136	UTS78D98P32.....	P. 40
UTS712D3P32.....	P. 48	UTS714D18S.....	P. 136	UTS78D98S.....	P. 40
UTS712D3S.....	P. 48	UTS714D18S32.....	P. 136	UTS78D98S32.....	P. 40
UTS712D3S32.....	P. 48	UTS714D19P.....	P. 140	UTS78E2P.....	P. 20
UTS712D4P.....	P. 52	UTS714D19P32.....	P. 140	UTS78E2S.....	P. 20

**Part Number Index (Continued)**

UTS78E33P.....	P. 44	HAUTS0V10E98SST100.....	P. 88	HAUTS0V14E15PRA100.....	P. 132
UTS78E33S.....	P. 44	HAUTS0V1210PRA100.....	P. 112	HAUTS0V14E15PST100.....	P. 132
UTS78E3AP.....	P. 40	HAUTS0V1210PST100.....	P. 112	HAUTS0V14E15SRA100.....	P. 132
UTS78E3AS.....	P. 40	HAUTS0V1210SRA100.....	P. 112	HAUTS0V14E15SST100.....	P. 132
UTS78E3P.....	P. 36	HAUTS0V1210SST100.....	P. 112	HAUTS0V14E18PRA100.....	P. 136
UTS78E3S.....	P. 36	HAUTS0V124PRA100.....	P. 52	HAUTS0V14E18PST100.....	P. 136
UTS78E4P.....	P. 60	HAUTS0V124PST100.....	P. 52	HAUTS0V14E18SRA100.....	P. 136
UTS78E4S.....	P. 60	HAUTS0V124SRA100.....	P. 52	HAUTS0V14E18SST100.....	P. 136
UTS78E98P.....	P. 40	HAUTS0V124SST100.....	P. 52	HAUTS0V14E19PRA100.....	P. 140
UTS78E98S.....	P. 40	HAUTS0V128PRA100.....	P. 100	HAUTS0V14E19PST100.....	P. 140
UTS7GJC104P.....	P. 68	HAUTS0V128PST100.....	P. 100	HAUTS0V14E19SRA100.....	P. 140
UTS7GJC128P.....	P. 100	HAUTS0V128SRA100.....	P. 100	HAUTS0V14E19SST100.....	P. 140
UTS7GJC1412P.....	P. 116	HAUTS0V128SST100.....	P. 100	HAUTS0V14E5PRA100.....	P. 72
UTS7GJC147P.....	P. 92	HAUTS0V12E10PRA100.....	P. 112	HAUTS0V14E5PST100.....	P. 72
UTS7GJC1492P.....	P. 124	HAUTS0V12E10PST100.....	P. 112	HAUTS0V14E5SRA100.....	P. 72
UTS7GN104P.....	P. 68	HAUTS0V12E10SRA100.....	P. 112	HAUTS0V14E5SST100.....	P. 72
UTS7GN128P.....	P. 100	HAUTS0V12E10SST100.....	P. 112	HAUTS0V14E7PRA100.....	P. 92
UTS7GN1412P.....	P. 116	HAUTS0V12E14PRA100.....	P. 128	HAUTS0V14E7PST100.....	P. 92
UTS7GN147P.....	P. 92	HAUTS0V12E14PST100.....	P. 128	HAUTS0V14E7SRA100.....	P. 92
UTS7GN1492P.....	P. 124	HAUTS0V12E14SRA100.....	P. 128	HAUTS0V14E7SST100.....	P. 92

**Overmoulded Cable Assemblies**

HAUTS0V102W2PRA100.....	P. 64	HAUTS0V12E2PRA100.....	P. 24	HAUTS0V1823PRA100.....	P. 144
HAUTS0V102W2PST100.....	P. 64	HAUTS0V12E2PST100.....	P. 24	HAUTS0V1823SRA100.....	P. 144
HAUTS0V102W2SRA100.....	P. 64	HAUTS0V12E2SRA100.....	P. 24	HAUTS0V1823SST100.....	P. 144
HAUTS0V102W2SST100.....	P. 64	HAUTS0V12E2SST100.....	P. 24	HAUTS0V1832PRA100.....	P. 148
HAUTS0V103PRA100.....	P. 28	HAUTS0V12E3PRA100.....	P. 48	HAUTS0V1832PST100.....	P. 148
HAUTS0V103PST100.....	P. 28	HAUTS0V12E3PST100.....	P. 48	HAUTS0V1832SRA100.....	P. 148
HAUTS0V103SRA100.....	P. 28	HAUTS0V12E3SRA100.....	P. 48	HAUTS0V1832SST100.....	P. 148
HAUTS0V103SST100.....	P. 28	HAUTS0V12E3SST100.....	P. 48	HAUTS0V8E2PRA100.....	P. 20
HAUTS0V103W3PRA100.....	P. 80	HAUTS0V12E4PRA100.....	P. 52	HAUTS0V8E2PST100.....	P. 20
HAUTS0V103W3PST100.....	P. 80	HAUTS0V12E4PST100.....	P. 52	HAUTS0V8E2SRA100.....	P. 20
HAUTS0V103W3SRA100.....	P. 80	HAUTS0V12E4SRA100.....	P. 52	HAUTS0V8E2SST100.....	P. 20
HAUTS0V103W3SST100.....	P. 80	HAUTS0V12E4SST100.....	P. 52	HAUTS0V8E33APRA100.....	P. 44
HAUTS0V104PRA100.....	P. 68	HAUTS0V12E8PRA100.....	P. 104	HAUTS0V8E33APST100.....	P. 44
HAUTS0V104PST100.....	P. 68	HAUTS0V12E8PST100.....	P. 104	HAUTS0V8E33ASRA100.....	P. 44
HAUTS0V104SRA100.....	P. 68	HAUTS0V12E8SRA100.....	P. 104	HAUTS0V8E33ASST100.....	P. 44
HAUTS0V104SST100.....	P. 68	HAUTS0V12E8SST100.....	P. 104	HAUTS0V8E3APRA100.....	P. 40
HAUTS0V106PRA100.....	P. 84	HAUTS0V1412PRA100.....	P. 116	HAUTS0V8E3APST100.....	P. 40
HAUTS0V106PST100.....	P. 84	HAUTS0V1412PST100.....	P. 116	HAUTS0V8E3ASRA100.....	P. 40
HAUTS0V106SRA100.....	P. 84	HAUTS0V1412SRA100.....	P. 116	HAUTS0V8E3ASST100.....	P. 40
HAUTS0V106SST100.....	P. 84	HAUTS0V1412SST100.....	P. 116	HAUTS0V8E3PRA100.....	P. 36
HAUTS0V10E6PRA100.....	P. 84	HAUTS0V1419PRA100.....	P. 140	HAUTS0V8E3PST100.....	P. 36
HAUTS0V10E6PST100.....	P. 84	HAUTS0V1419PST100.....	P. 140	HAUTS0V8E3SRA100.....	P. 36
HAUTS0V10E6SRA100.....	P. 84	HAUTS0V1419SRA100.....	P. 140	HAUTS0V8E3SST100.....	P. 36
HAUTS0V10E6SST100.....	P. 84	HAUTS0V1419SST100.....	P. 140	HAUTS0V8E4PRA100.....	P. 60
HAUTS0V10E7PRA100.....	P. 96	HAUTS0V147PRA100.....	P. 92	HAUTS0V8E4PST100.....	P. 60
HAUTS0V10E7PST100.....	P. 96	HAUTS0V147PST100.....	P. 92	HAUTS0V8E4SRA100.....	P. 60
HAUTS0V10E7SRA100.....	P. 96	HAUTS0V147SRA100.....	P. 92	HAUTS0V8E4SST100.....	P. 60
HAUTS0V10E7SST100.....	P. 96	HAUTS0V147SST100.....	P. 92		
HAUTS0V10E98PRA100.....	P. 88	HAUTS0V14E12PRA100.....	P. 120		
HAUTS0V10E98PST100.....	P. 88	HAUTS0V14E12PST100.....	P. 120		
HAUTS0V10E98SRA100.....	P. 88	HAUTS0V14E12SRA100.....	P. 120		
		HAUTS0V14E12SST100.....	P. 120		

## Accessories

85005585A.....	P. 22
85005586A.....	P. 30
85005587A.....	P. 26
85005588A.....	P. 34
85005590A.....	P. 58
85005594.....	P. 22
85005595.....	P. 30
85005596.....	P. 26
85005597.....	P. 34
85005599.....	P. 58
UTS18DCG2.....	P. 154
UTS610CCRG.....	P. 30
UTS610CCRR.....	P. 30
UTS610CCRY.....	P. 30
UTS612CCRG.....	P. 26
UTS612CCRR.....	P. 26
UTS612CCRY.....	P. 26
UTS614CCRG.....	P. 34
UTS614CCRR.....	P. 34
UTS614CCRY.....	P. 34
UTS618CCRG.....	P. 58
UTS618CCRR.....	P. 58
UTS618CCRY.....	P. 58
UTS618DCG2.....	P. 154
UTFD11B.....	P. 22
UTFD12B.....	P. 30
UTFD13B.....	P. 26
UTFD14B.....	P. 34
UTFD16B.....	P. 58
UTS10DCG.....	P. 30
UTS10DCGE.....	P. 74
UTS10DCGR.....	P. 30
UTS12DCG.....	P. 26
UTS12DCGE.....	P. 26
UTS12DCGR.....	P. 26
UTS14DCG.....	P. 34
UTS14DCGE.....	P. 78
UTS14DCGR.....	P. 34
UTS18DCG.....	P. 58
UTS18DCGE.....	P. 146
UTS18DCGR.....	P. 58
UTS610DCG.....	P. 30
UTS612DCG.....	P. 26
UTS614DCG.....	P. 34
UTS618DCG.....	P. 58
UTS68C.....	P. 22
UTS68CCRG.....	P. 22
UTS68CCRR.....	P. 22
UTS68CCRY.....	P. 22
UTS710CCRG.....	P. 30
UTS710CCRR.....	P. 30
UTS710CCRY.....	P. 30

UTS712CCRG.....	P. 26
UTS712CCRR.....	P. 26
UTS712CCRY.....	P. 26
UTS714CCRG.....	P. 34
UTS714CCRR.....	P. 34
UTS714CCRY.....	P. 34
UTS718CCRG.....	P. 58
UTS718CCRR.....	P. 58
UTS718CCRY.....	P. 58
UTS78CCRG.....	P. 22
UTS78CCRR.....	P. 22
UTS78CCRY.....	P. 22
UTS8DCGE.....	P. 22
UTS8DCGR.....	P. 22

## Contacts

82911456A.....	P. 165
82911456K.....	P. 165
82911457NA.....	P. 165
82911457NK.....	P. 165
82911458A.....	P. 165
82911458K.....	P. 165
82911459NA.....	P. 165
82911459NK.....	P. 165
82911460A.....	P. 165
82911460K.....	P. 165
82911461NA.....	P. 165
82911461NK.....	P. 165
82911462A.....	P. 165
82911462K.....	P. 165
82911463NA.....	P. 165
82911463NK.....	P. 165
82911464A.....	P. 165
82911464K.....	P. 165
82911465NA.....	P. 165
82911465NK.....	P. 165
82911466A.....	P. 165
82911466K.....	P. 165
82911467NA.....	P. 165
82911467NK.....	P. 165
82911684NPC.....	P. 168
82911685NPC.....	P. 168
82913600A.....	P. 165
82913601A.....	P. 165
82913602A.....	P. 165
82913603A.....	P. 165
82913604A.....	P. 165
82913605A.....	P. 165
82913606A.....	P. 165
82913607A.....	P. 165
82913608A.....	P. 165
82913609A.....	P. 165
RC14M30GE7K.....	P. 166

RC14M30K.....	P. 165
RC16M23GE7K.....	P. 166
RC16M23K.....	P. 165
RC18W3K.....	P. 165
RC20M12E8K.....	P. 168
RC20M12E83K.....	P. 168
RC20M12E84J.....	P. 168
RC20M12E85K.....	P. 168
RC20M12E86K.....	P. 168
RC20M12E87K.....	P. 168
RC20M12GE7K.....	P. 166
RC20M12K.....	P. 165
RC20M13GE7K.....	P. 166
RC20M13K.....	P. 165
RC20W3K.....	P. 165
RC24M9GE7K.....	P. 166
RC24M9K.....	P. 165
RC24W3K.....	P. 165
RC28M1GE7K.....	P. 166
RC28M1K.....	P. 165
RCDX6015D28.....	P. 201
RCDX6016D28.....	P. 200
RCDX6018D28.....	P. 200
RCDX6019D28.....	P. 201
RCDX6024D28.....	P. 200
RCDX6026D28.....	P. 200
RCDX602D28.....	P. 205
RCDX6031D28.....	P. 201
RCDX6032D28.....	P. 200
RCDX6034D28.....	P. 200
RCDX6036D28.....	P. 200
RCDX6052D28.....	P. 200
RCDXB0553.....	P. 205
RCDXK1D28.....	P. 200
RCPOF1000B.....	P. 171
RCW5016K.....	P. 168
RCW50A7K.....	P. 168
RFD26L1D28.....	P. 196
RM14M30GE1K.....	P. 166
RM14M30K.....	P. 165
RM16M23GE1K.....	P. 166
RM16M23K.....	P. 165
RM18W3K.....	P. 165
M20M12E8K.....	P. 168
RM20M12E83K.....	P. 168
RM20M12E84K.....	P. 168
RM20M12GE1K.....	P. 166
RM20M12K.....	P. 165
RM20M13GE1K.....	P. 166
RM20M13K.....	P. 165
RM20W3K.....	P. 165
RM24M9GE1K.....	P. 166
RM24M9K.....	P. 165





# Reliable People, Reliable Solutions



Your local contact



Our contribution to environmental protection:  
This catalog is printed on PEFC certified paper  
Advancement of sustainable wood cultivation. [www.pefc.org](http://www.pefc.org)

# SOURIAU

[www.souriau-industrial.com](http://www.souriau-industrial.com)  
[contactindustry@souriau.com](mailto:contactindustry@souriau.com)





Компания «Life Electronics» занимается поставками электронных компонентов импортного и отечественного производства от производителей и со складов крупных дистрибьюторов Европы, Америки и Азии.

С конца 2013 года компания активно расширяет линейку поставок компонентов по направлению коаксиальный кабель, кварцевые генераторы и конденсаторы (керамические, пленочные, электролитические), за счёт заключения дистрибьюторских договоров

Мы предлагаем:

- Конкурентоспособные цены и скидки постоянным клиентам.
- Специальные условия для постоянных клиентов.
- Подбор аналогов.
- Поставку компонентов в любых объемах, удовлетворяющих вашим потребностям.
- Приемлемые сроки поставки, возможна ускоренная поставка.
- Доставку товара в любую точку России и стран СНГ.
- Комплексную поставку.
- Работу по проектам и поставку образцов.
- Формирование склада под заказчика.
- Сертификаты соответствия на поставляемую продукцию (по желанию клиента).
- Тестирование поставляемой продукции.
- Поставку компонентов, требующих военную и космическую приемку.
- Входной контроль качества.
- Наличие сертификата ISO.

В составе нашей компании организован Конструкторский отдел, призванный помогать разработчикам, и инженерам.

Конструкторский отдел помогает осуществить:

- Регистрацию проекта у производителя компонентов.
- Техническую поддержку проекта.
- Защиту от снятия компонента с производства.
- Оценку стоимости проекта по компонентам.
- Изготовление тестовой платы монтаж и пусконаладочные работы.



Тел: +7 (812) 336 43 04 (многоканальный)

Email: [org@lifeelectronics.ru](mailto:org@lifeelectronics.ru)