

Ordering a market-ready enclosure® is made fast and affordable with our complete in-house capabilities. New Age provides machined openings to fit your PCB, pad printing for your graphics, custom enclosures, custom colors, final assembly, testing and fulfillment services to save you additional time and money. Ask your representative for a free quote today 805-595-1310.

Fast and Affordable Customization

**CNC Modifications
Pad Printing
Colored Resins
EMI/RF Shielding
Custom Enclosure
Assembly & Testing**



ISO quality
off-the-shelf
to market-ready®

NEW AGE ENCLOSURES

www.NewAgeEnclosures.com

4330 Santa Fe Road • San Luis Obispo, CA 93401 • T 805.595.1310 • F 805.595.1024

NOTES: UNLESS OTHERWISE SPECIFIED

1. CORNERS DRAWN SHARP TO BE R.005 MAXIMUM.
2. EXTERIOR SURFACE TEXTURE TO BE LIGHT EDM FINISH. EQUIVALENT TO MT-11020.
3. INTERIOR SURFACE TEXTURE TO BE: NONE
4. ALL INSIDE RADII .010R. ALL OUTSIDE RADII .020R MAX, UNLESS OTHERWISE SPECIFIED.
5. ALL EXTERNAL DIMENSIONS AFFECTED BY THE DRAFT APPLY AT THE LARGE END OF THE FEATURE, AND ALL INTERNAL FEATURES AFFECTED BY THE DRAFT APPLY AT THE SMALL END OF THE FEATURE UNLESS OTHERWISE SPECIFIED.
6. 1 DEGREE DRAFT IN THE DIRECTION OF PULL IS PERMISSIBLE UNLESS OTHERWISE SPECIFIED.
7. MATERIAL / COLOR: ABS PLASTIC IS STANDARD IN BLACK OR WHITE. CUSTOM MATERIALS AND COLORS ARE AVAILABLE UPON REQUEST FOR QUOTE.
8. PCB SIZES ARE RECOMMENDATIONS ONLY. FINAL SIZES AND VERIFICATION OF ITS FIT ARE THE SOLE RESPONSIBILITY OF EACH CUSTOMER.
9. ASSEMBLY HARDWARE PROVIDED. BATTERY CONTACTS SOLD SEPERATELY
10. THIS DRAWING IS BASED ON A SOLID MODEL, AND IS FURTHER DEFINED BY THE SOLID MODEL FILE.

R E V I S I O N

REV.	DRAWN BY	ECO No	DESCRIPTION	DATE	APPROVED
1	M BOYER		PRELIMINARY RELEASE	16-Mar-2009	D.C.
2	M BOYER	2109	UPDATE MODEL, ADD DRAFT AND FORMAT	18-Apr-2009	D.C.
3	M BOYER	4309	ADD SURFACE CALLOUT AND MODIFY HATCH	14-Dec-2009	D.C.
3.1	M BOYER	0710	UPDATE FORMAT	20-Mar-2010	D.C.
4.0	M BOYER	1210	ADD CORING IN REAR	04-May-2010	D.C.
4.1	M BOYER	2810	UPDATE VIEWS AND 2ND-OP PAGE	28-Jul-2010	D.C.
5.0	R CRUZ	7713	ADD "TALL" CONFIGURATION	01-Nov-2013	D.C.
6.0	R CRUZ	2214	INCLUDE WALL CRADLE OPTION	19-May-2014	D.C.
7.0	M BOYER	0814	CHANGE TEXTURE CALLOUT	21-May-2014	D.C.
7.1	R CRUZ	0361	UPDATE WALL CRADLE DIMENSIONS TO AS BUILT	18-Jun-2014	D.C.
8.0	M BOYER	5214	REMOVE TALL CONFIG AND INCLUDE PCB NOTCH	15-Dec-2014	

251510(x) CONFIGURATIONS			
	-Blank	-K	-WP
251510 COVER	1	1	
251510 BASE	1		
251510 MACHINED BASE		1	
251510 HATCH	1	1	
251510 WALL CRADLE		1	1
#2 HILO SCREW .375"	4	4	

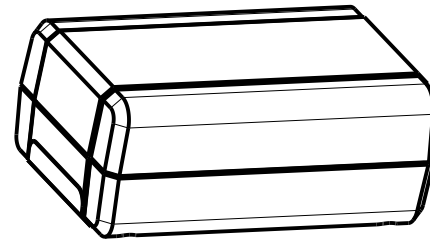

STANDARD 251510
SCALE 0.750

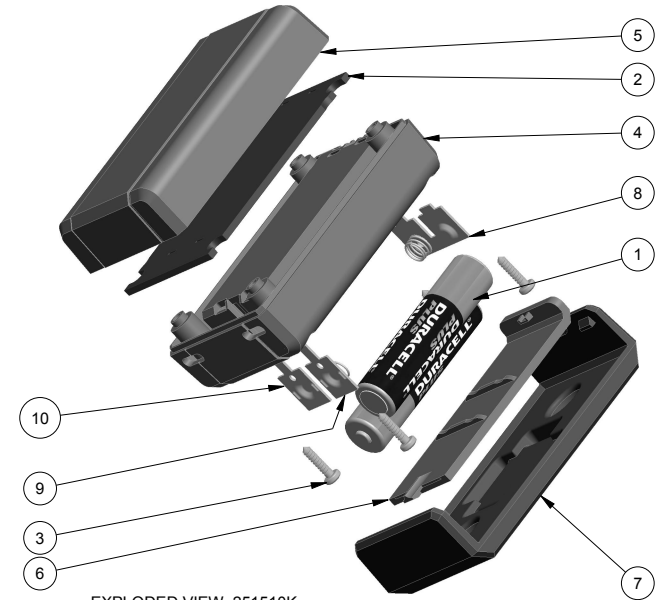

EXPLODED VIEW 251510K
SCALE 0.600

10	AAA-SINGL-CONTACT-POS	ACC-AAAPOS-5226	SPRING STEEL	SOLD SEPERATELY	1
9	AAA-SINGL-CONTACT-NEG	ACC-AAANEG-5204	SPRING STEEL	SOLD SEPERATELY	1
8	AAA-DBL-CONTACT	ACC-AAADBL-5214L	SPRING STEEL	SOLD SEPERATELY	1
7	251510_WALL-CRADLE	251510 WALL CRADLE - STANDARD	ABS	BLACK or WHITE	1
6	251510_HATCH	251510 HATCH - STANDARD	ABS	BLACK or WHITE	1
5	251510_COVER	251510 COVER - STANDARD	ABS	BLACK or WHITE	1
4	251510_BASE	251510 BASE - STANDARD	ABS	BLACK or WHITE	1
3	NO_2_HI-LO_SCREW	No2 HI-LO x .375"	STEEL	3/8" LONG	4
2	251510_PCB	REFERENCE ONLY	CUSTOMER SUPPLIED	.062" THICK	1
1	AAA-BATTERY	REFERENCE ONLY	CUSTOMER SUPPLIED	"AAA" SIZE	2
ITEM	FILE NAME	DESCRIPTION	MATERIAL	COLOR	QTY.

BILL OF MATERIALS

THIRD ANGLE PROJECTION
DO NOT SCALE DRAWING

TOLERANCES: UNLESS OTHERWISE SPECIFIED
DIMENSIONS ARE IN U.S. INCHES.
X.XX = .015 X.XXXX = .001
X.XXX = .010 X.X" = 1°

NEW AGE ENCLOSURES
4330 Santa Fe Road San Luis Obispo, CA. 93401
ph. (805) 595-1310 fax (805) 595-1024
www.newageenclosures.com

Customer's Part No: 251510

APPROVAL	BY	DATE
CHECK		
ENG.		
SCALE	AS NOTED	
DRAWN BY	M BOYER	
	16-Mar-2009	

**STANDARD - MINI AAA
SXX-251510X ASSEMBLY**

SIZE	DRAWING NAME	SHEET	REV.DOC
A	251510_R8_0	1 OF 8	8.0

SECTION C-C

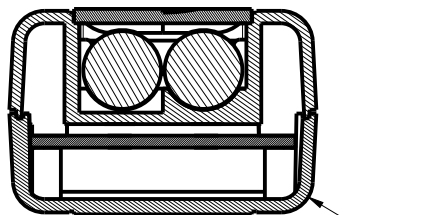

R.165

P ← F ←

SEE DETAIL B

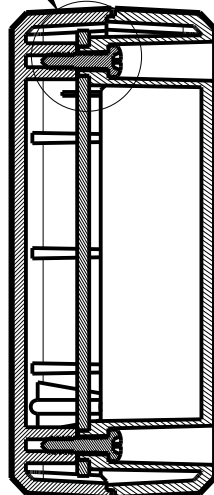

SECTION F-F

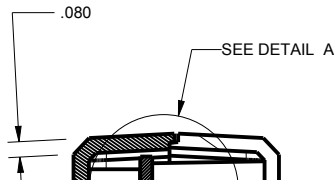

SECTION P-P

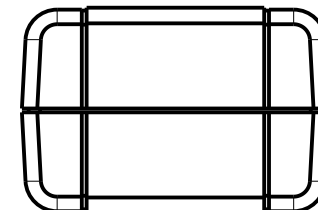

1.599

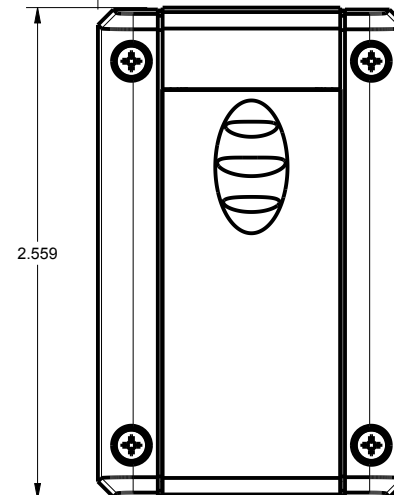

2.559

.925

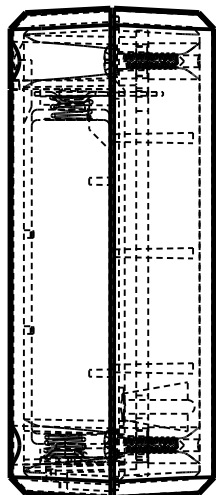

SCALE 1.000

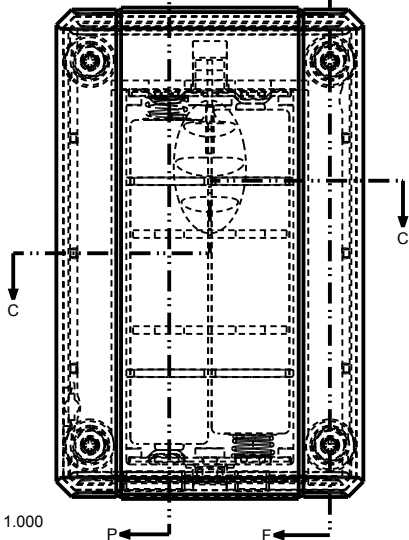

C ↓

P ← F ←

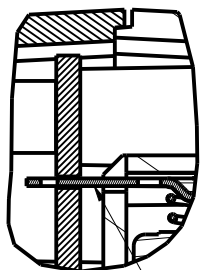

DETAIL A
SCALE 2.000

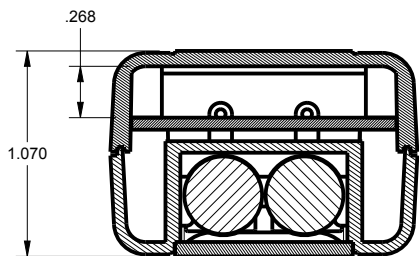

SECTION Y-Y

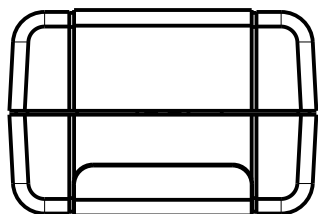

PCB CAPTURED

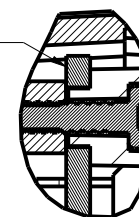

DETAIL B
SCALE 2.000

NOTE: BATTERY CONTACT TABS CAN BE PUSHED THROUGH THE PCB AND SOLDERED TO THE SURFACE OR THE TAB CAN BE BENT BACK AT 90° AND WIRED.

TOLERANCES: UNLESS OTHERWISE SPECIFIED
DIMENSIONS ARE IN U.S. INCHES.
X.XX = .015 X.XXXX = .001
X.XXX = .010 X.X° = 1°

NEW AGE ENCLOSURES

Customer's Part No: 251510

APPROVAL BY DATE

CHECK

ENG.

SCALE AS NOTED

DRAWN BY M BOYER 16-Mar-2009

NEW AGE ENCLOSURES

4330 Santa Fe Road San Luis Obispo, CA. 93401
ph. (805) 595-1310 fax (805) 595-1024
www.newageenclosures.com

**STANDARD - MINI AAA
SXX-251510X ASSEMBLY**

SIZE A DRAWING NAME 251510_R8_0

SHEET 2 OF 8 REV.DOC 8.0

S251510 - COVER

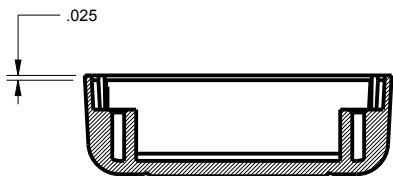

SECTION F-F

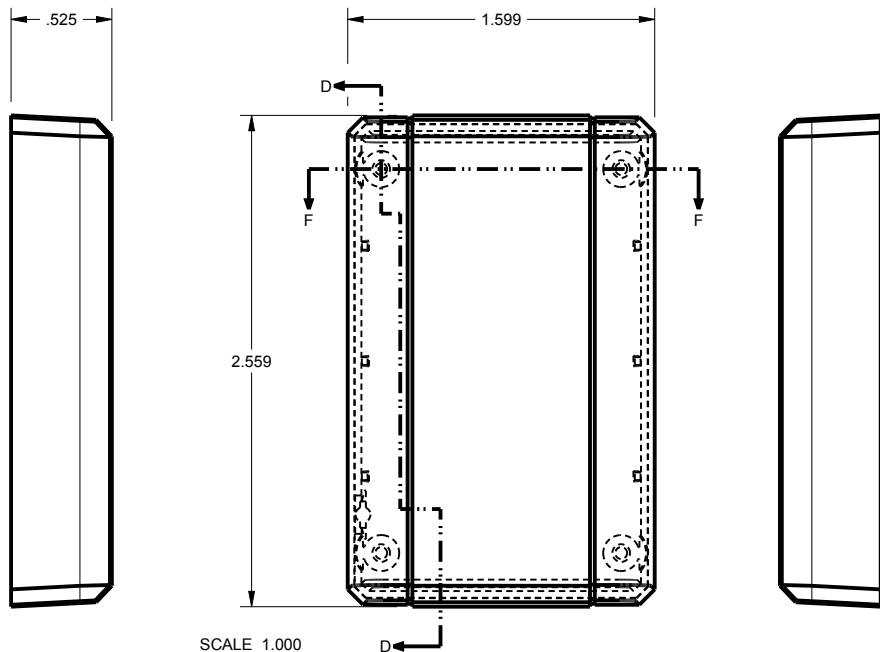

SCALE 1.000

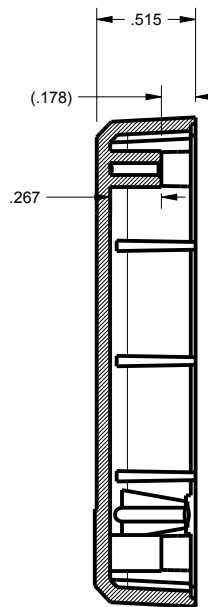

251510 STANDARD SECTION D-D

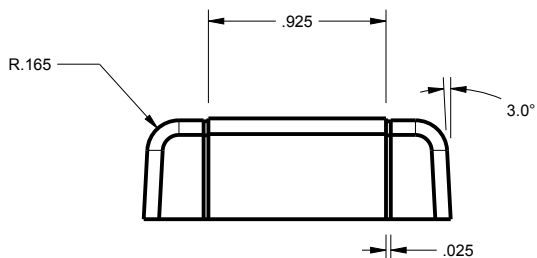
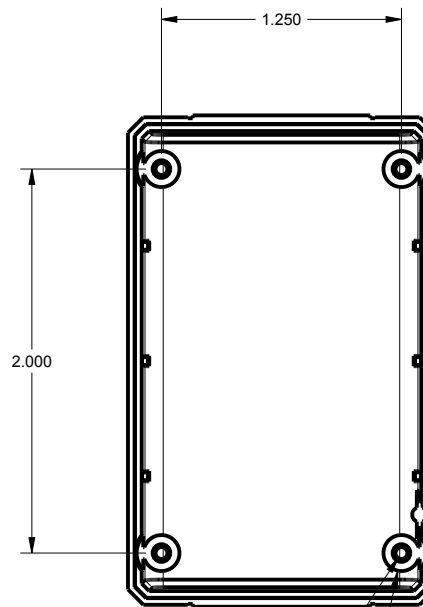

TOLERANCES: UNLESS OTHERWISE SPECIFIED
DIMENSIONS ARE IN U.S. INCHES.
X.XX = .015 X.XXXX = .001
X.XXX = .010 X.X° = 1°

NEW AGE ENCLOSURES
Customer's Part No: 251510

APPROVAL	BY	DATE
CHECK		
ENG.		
SCALE	AS NOTED	

DRAWN BY	16-Mar-2009
M BOYER	

NEW AGE ENCLOSURES
4330 Santa Fe Road San Luis Obispo, CA. 93401
ph. (805) 595-1310 fax (805) 595-1024
www.newageenclosures.com

**STANDARD - MINI AAA
SXX-251510X ASSEMBLY**

SIZE	DRAWING NAME	SHEET	REV.DOC
A	251510_R8_0	3 OF 8	8.0

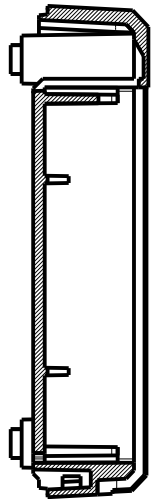
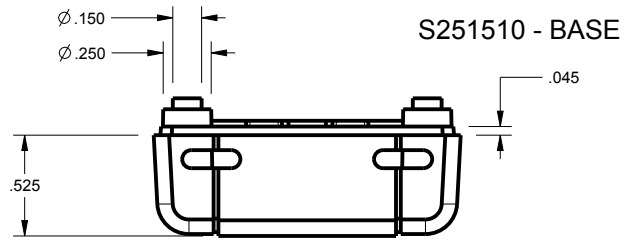

SECTION J-J

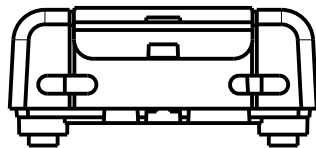
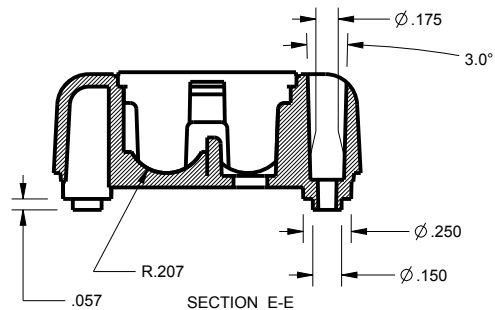
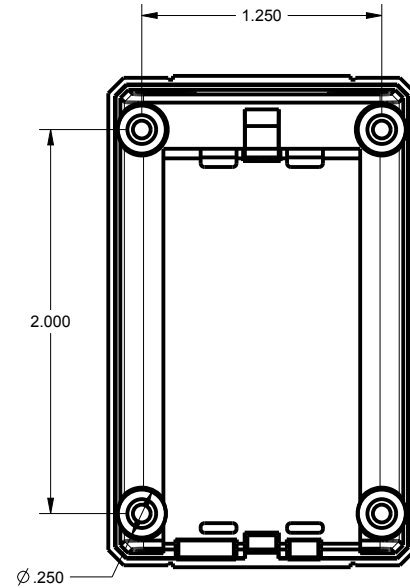
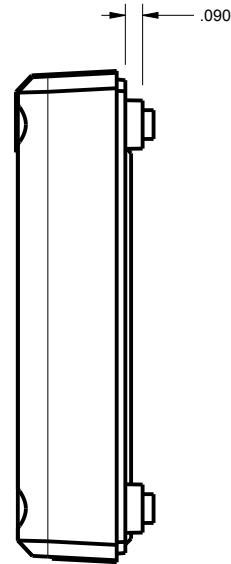
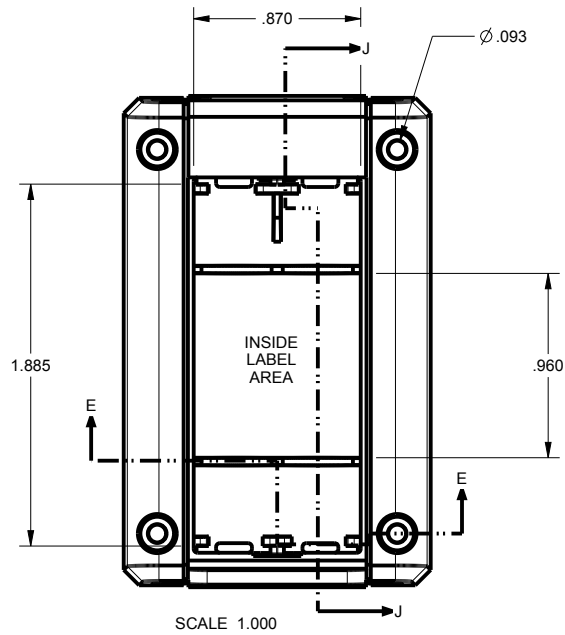

TOLERANCES: UNLESS OTHERWISE SPECIFIED DIMENSIONS ARE IN U.S. INCHES.
 X.XX = .015 X.XXXX = .001
 X.XXX = .010 X.X° = 1°

NEW AGE ENCLOSURES
 Customer's Part No: 251510

APPROVAL	BY	DATE
CHECK		
ENG.		
SCALE	AS NOTED	
DRAWN BY	16-Mar-2009	
M BOYER		

NEW AGE ENCLOSURES
 4330 Santa Fe Road San Luis Obispo, CA. 93401
 ph. (805) 595-1310 fax (805) 595-1024
www.newageenclosures.com

**STANDARD - MINI AAA
 SXX-251510X ASSEMBLY**

SIZE	DRAWING NAME	SHEET	REV.DOC
A	251510_R8_0	4 OF 8	8.0

S251510 - WALL CRADLE

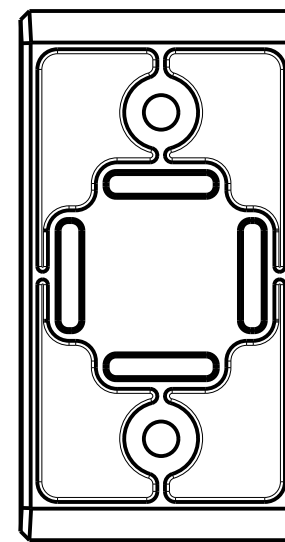
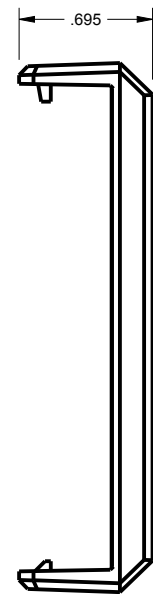
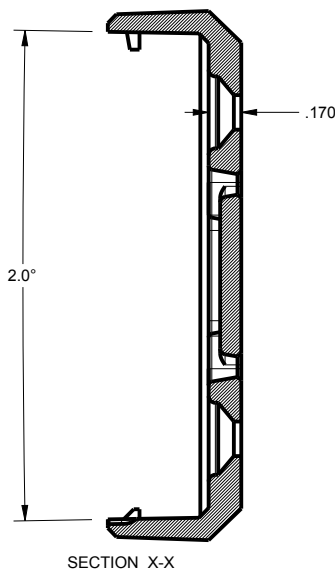
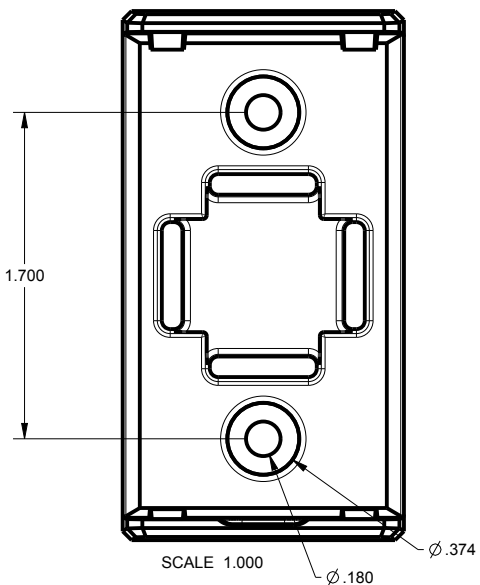
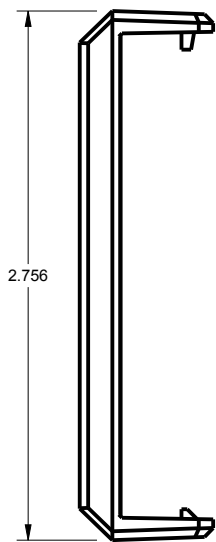
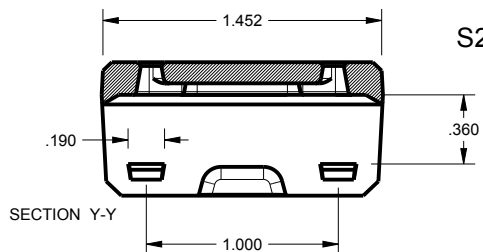

2nd OPERATION REQUIRED
ON 251510 BASE
TO ACCEPT CRADLE TABS

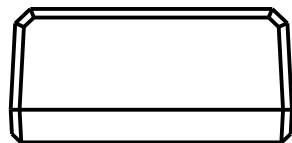
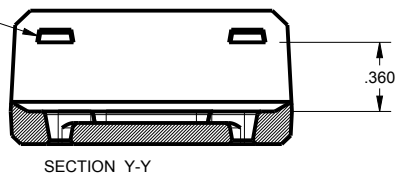

TOLERANCES: UNLESS OTHERWISE SPECIFIED
DIMENSIONS ARE IN U.S. INCHES.
X.XX = .015 X.XXXX = .001
X.XXX = .010 X.X° = 1°

NEW AGE ENCLOSURES

Customer's Part No: 251510

APPROVAL BY DATE

CHECK

ENG.

SCALE AS NOTED

DRAWN BY M BOYER 16-Mar-2009

NEW AGE ENCLOSURES

4330 Santa Fe Road San Luis Obispo, CA. 93401
ph. (805) 595-1310 fax (805) 595-1024
www.newageenclosures.com

STANDARD - MINI AAA
SXX-251510X ASSEMBLY

SIZE A DRAWING NAME 251510_R8_0 SHEET 5 OF 8 REV.DOC

8.0

S251510 - PCB

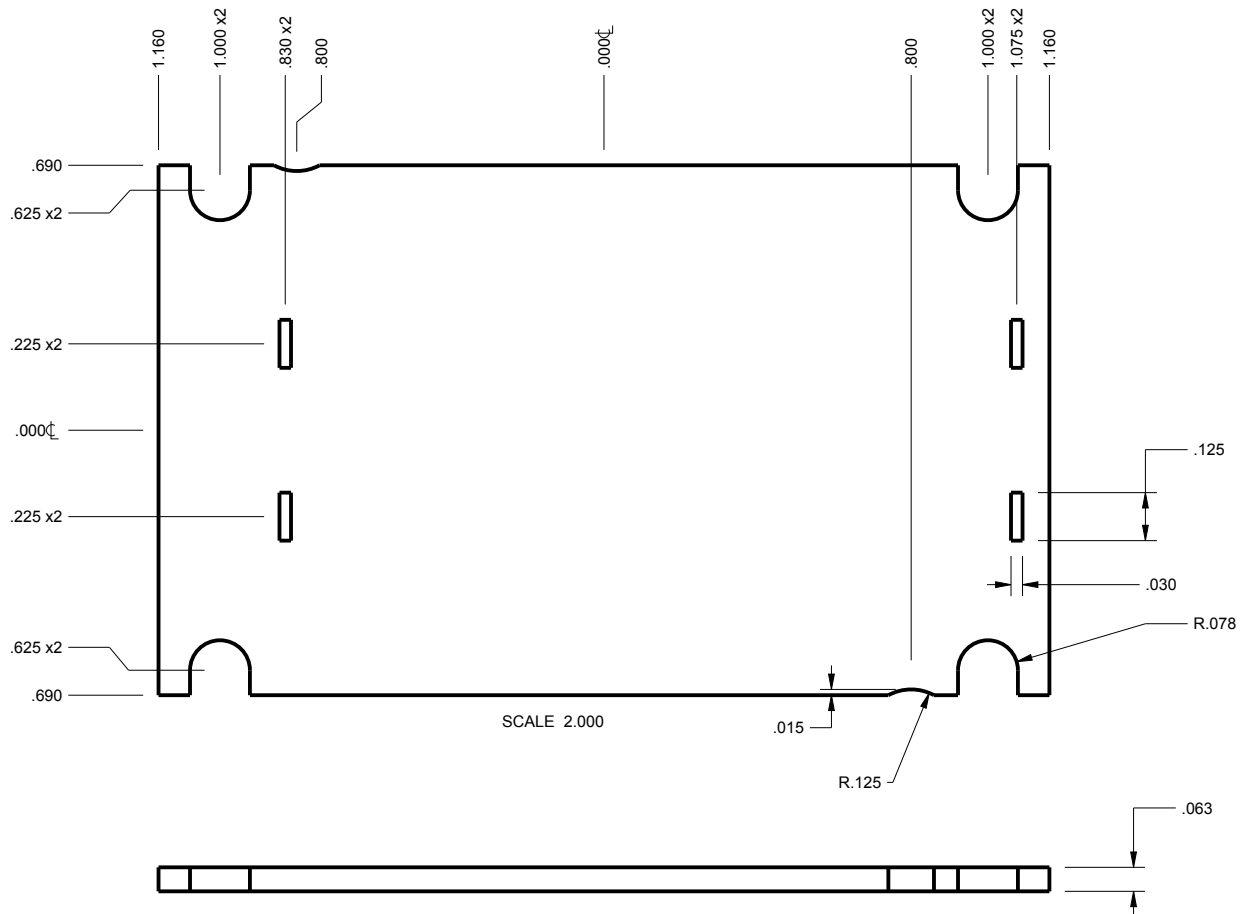

SCALE 2.000

NOTE
1. BATTERY CONNECTION POINTS SHOWN AT BOTH ENDS
TO ALLOW ALTERNATE ASSEMBLY OPTION.

TOLERANCES: UNLESS OTHERWISE SPECIFIED
DIMENSIONS ARE IN U.S. INCHES.
X.XX = .015 X.XXXX = .001
X.XXX = .010 X.X° = 1°

NEW AGE ENCLOSURES
Customer's Part No: 251510

APPROVAL	BY	DATE
CHECK		
ENG.		
SCALE	AS NOTED	

DRAWN BY
M BOYER

16-Mar-2009

NEW AGE ENCLOSURES
4330 Santa Fe Road San Luis Obispo, CA. 93401
ph. (805) 595-1310 fax (805) 595-1024
www.newageenclosures.com

STANDARD - MINI AAA
SXX-251510X ASSEMBLY

SIZE	DRAWING NAME	SHEET	REV.DOC
A	251510_R8_0	6 OF 8	8.0

2nd OPERATION DETAILS (PAGE 1 OF 2)

NEW AGE ENCLOSURES DELIVERS YOUR ENCLOSURE MARKET-READY WITH IN-HOUSE
CNC MACHINING, PAD PRINTING, ASSEMBLY, AND FULFILLMENT.
ALL SURFACES AND AREAS ARE AVAILABLE FOR CNC ALTERATION BY NEW AGE ENCLOSURES
CALL (805) 595-1310 FOR PRICING AND SCHEDULE.
THE INSIDE RADIUS OF ANY MACHINED FEATURES SHOULD BE NO SMALLER THAN .031"

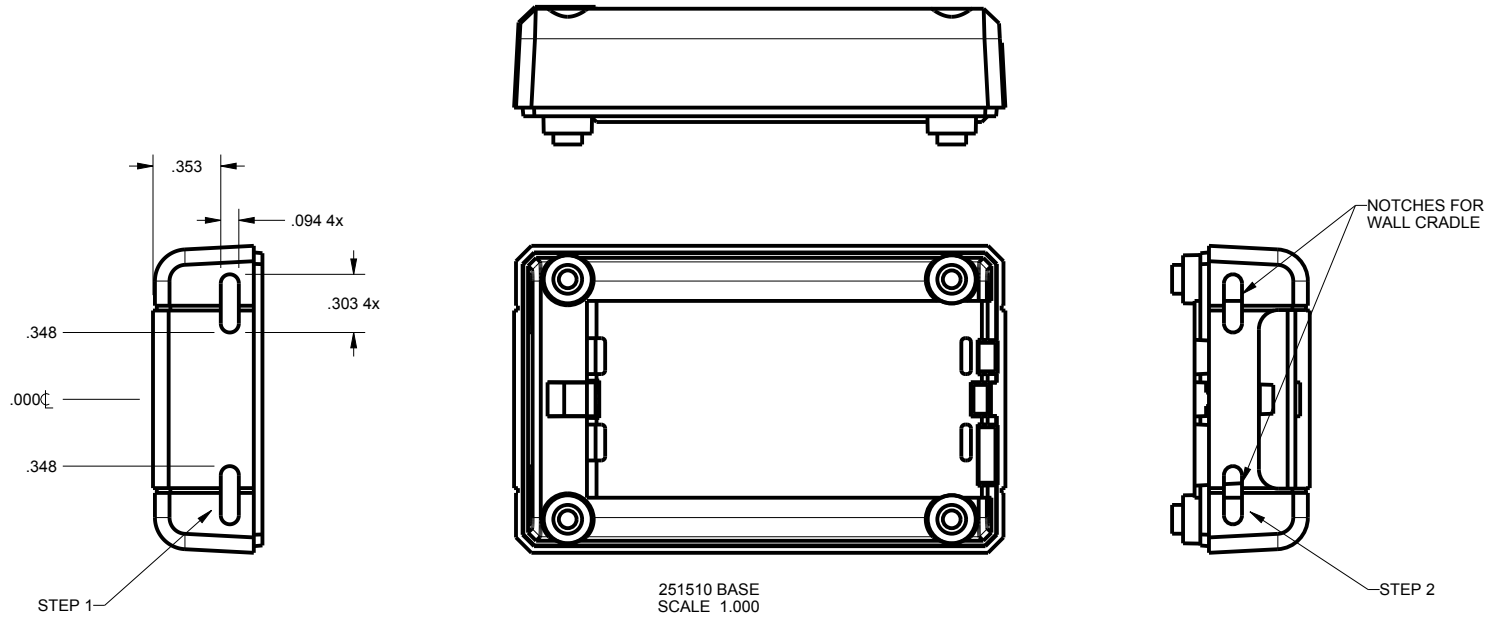

SXX-251510X-XXX BASE - ABS, BLACK					
STEP NO	DESCRIPTION	CUTTER	FIXTURE	ORIENTATION	PROGRAM
1-B-C1	CRADLE NOTCHES	T2 = .062" EM	190	SINGLE	-
2-B-C2	CRADLE NOTCHES	T2 = .062" EM	190	SINGLE	-

TOLERANCES: UNLESS OTHERWISE SPECIFIED DIMENSIONS ARE IN U.S. INCHES. X.XX = .015 X.XXXX = .001 X.XXX = .010 X.X° = 1°		NEW AGE ENCLOSURES	
NEW AGE ENCLOSURES		4330 Santa Fe Road San Luis Obispo, CA. 93401 ph. (805) 595-1310 fax (805) 595-1024 www.newageenclosures.com	
Customer's Part No: 251510			
APPROVAL	BY	DATE	STANDARD - MINI AAA SXX-251510X ASSEMBLY
CHECK			
ENG.			
SCALE	AS NOTED		
DRAWN BY	M BOYER	16-Mar-2009	SIZE
DRAWING NAME	A 251510_R8_0		SHEET
REV.DOC	7 OF 8		8.0

2nd OPERATION DETAILS (PAGE 2 OF 2)

NEW AGE ENCLOSURES DELIVERS YOUR ENCLOSURE MARKET-READY WITH IN-HOUSE
CNC MACHINING, PAD PRINTING, ASSEMBLY, AND FULFILLEMENT.
ALL SURFACES AND AREAS ARE AVAILABLE FOR CNC ALTERATION BY NEW AGE ENCLOSURES
CALL (805) 595-1310 FOR PRICING AND SCHEDULE.
THE INSIDE RADIUS OF ANY MACHINED FEATURES SHOULD BE NO SMALLER THAN .031"

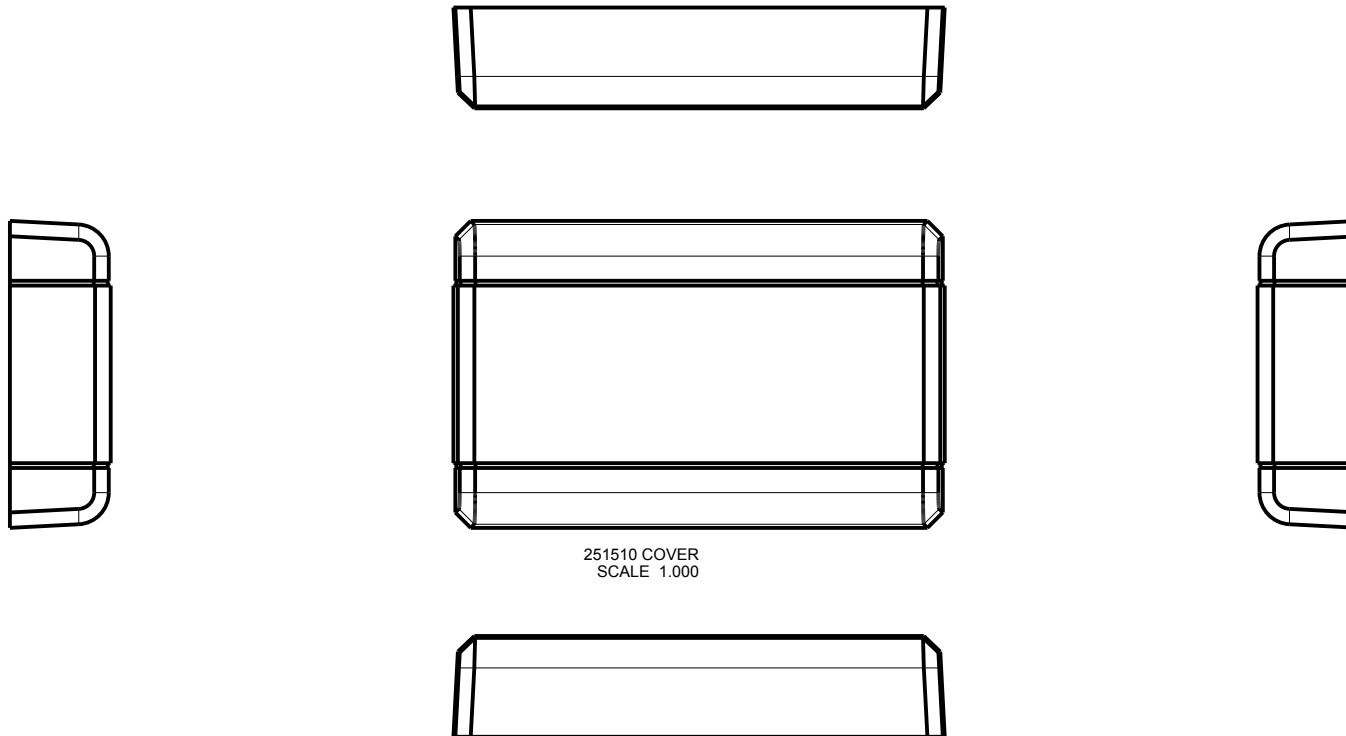

251510 COVER
SCALE 1.000

TOLERANCES: UNLESS OTHERWISE SPECIFIED
DIMENSIONS ARE IN U.S. INCHES.
X.XX = .015 X.XXXX = .001
X.XXX = .010 X.X° = 1°

NEW AGE ENCLOSURES

Customer's Part No: 251510

NEW AGE ENCLOSURES

4330 Santa Fe Road San Luis Obispo, CA. 93401
ph. (805) 595-1310 fax (805) 595-1024

www.newageenclosures.com

APPROVAL	BY	DATE
CHECK		
ENG.		
SCALE	AS NOTED	
DRAWN BY		
M BOYER	16-Mar-2009	

**STANDARD - MINI AAA
SXX-251510X ASSEMBLY**

SIZE	DRAWING NAME	SHEET	REV.DOC
A	251510_R8_0	8 OF 8	8.0

SXX-251510X-XXX COVER - ABS, BLACK

STEP NO	DESCRIPTION	CUTTER	FIXTURE	ORIENTATION	PROGRAM
1-C-C1	-	T2 = .062" EM	190	-	-
2-C-C2	-	T2 = .062" EM	190	-	-

Mouser Electronics

Authorized Distributor

Click to View Pricing, Inventory, Delivery & Lifecycle Information:

[New Age Enclosures:](#)

[S1A-251510](#) [S3A-251510](#) [S3A-251510-K](#) [S1A-251510-K](#)

Компания «Life Electronics» занимается поставками электронных компонентов импортного и отечественного производства от производителей и со складов крупных дистрибьюторов Европы, Америки и Азии.

С конца 2013 года компания активно расширяет линейку поставок компонентов по направлению коаксиальный кабель, кварцевые генераторы и конденсаторы (керамические, пленочные, электролитические), за счёт заключения дистрибьюторских договоров

Мы предлагаем:

- Конкурентоспособные цены и скидки постоянным клиентам.
- Специальные условия для постоянных клиентов.
- Подбор аналогов.
- Поставку компонентов в любых объемах, удовлетворяющих вашим потребностям.
- Приемлемые сроки поставки, возможна ускоренная поставка.
- Доставку товара в любую точку России и стран СНГ.
- Комплексную поставку.
- Работу по проектам и поставку образцов.
- Формирование склада под заказчика.
- Сертификаты соответствия на поставляемую продукцию (по желанию клиента).
- Тестирование поставляемой продукции.
- Поставку компонентов, требующих военную и космическую приемку.
- Входной контроль качества.
- Наличие сертификата ISO.

В составе нашей компании организован Конструкторский отдел, призванный помогать разработчикам, и инженерам.

Конструкторский отдел помогает осуществить:

- Регистрацию проекта у производителя компонентов.
- Техническую поддержку проекта.
- Защиту от снятия компонента с производства.
- Оценку стоимости проекта по компонентам.
- Изготовление тестовой платы монтаж и пусконаладочные работы.



Тел: +7 (812) 336 43 04 (многоканальный)

Email: org@lifeelectronics.ru