

Base strip - MCVK 1,5/15-G-3,81 - 1832866

Please be informed that the data shown in this PDF Document is generated from our Online Catalog. Please find the complete data in the user's documentation. Our General Terms of Use for Downloads are valid (<http://phoenixcontact.com/download>)



Plug component, Nominal current: 8 A, Rated voltage (III/2): 160 V, Number of positions: 15, Pitch: 3.81 mm, Connection method: Screw connection with tension sleeve, Color: green, Contact surface: Tin, Mounting: DIN rail

The illustration shows a 16-position version



Key Commercial Data

Packing unit	1 pc
GTIN	 4 017918 051600
Weight per Piece (excluding packing)	19.4 g
Custom tariff number	85369010
Country of origin	Poland

Technical data

Dimensions

Pitch	3.81 mm
Dimension a	53.34 mm

General

Range of articles	MCVK 1,5/..-G
Insulating material group	I
Rated surge voltage (III/3)	2.5 kV
Rated surge voltage (III/2)	2.5 kV
Rated surge voltage (II/2)	2.5 kV
Rated voltage (III/3)	160 V
Rated voltage (III/2)	160 V

Base strip - MCVK 1,5/15-G-3,81 - 1832866

Technical data

General

Rated voltage (U/2)	320 V
Connection in acc. with standard	EN-VDE
Nominal current I _N	8 A
Nominal cross section	1.5 mm ²
Maximum load current	8 A
Insulating material	PA
Flammability rating according to UL 94	V0
Internal cylindrical gage	A1
Stripping length	7 mm
Number of positions	15
Screw thread	M2
Tightening torque, min	0.22 Nm
Tightening torque max	0.25 Nm

Connection data

2 conductors with same cross section, solid min.	0.14 mm ²
2 conductors with same cross section, solid max.	0.5 mm ²
2 conductors with same cross section, stranded min.	0.14 mm ²
2 conductors with same cross section, stranded max.	0.75 mm ²
2 conductors with same cross section, stranded, ferrules without plastic sleeve, min.	0.25 mm ²
2 conductors with same cross section, stranded, ferrules without plastic sleeve, max.	0.34 mm ²
2 conductors with same cross section, stranded, TWIN ferrules with plastic sleeve, min.	0.5 mm ²
2 conductors with same cross section, stranded, TWIN ferrules with plastic sleeve, max.	0.5 mm ²
Minimum AWG according to UL/CUL	30
Maximum AWG according to UL/CUL	14

Standards and Regulations

Connection in acc. with standard	EN-VDE
	CSA
Flammability rating according to UL 94	V0

Classifications

eCl@ss

eCl@ss 4.0	272607xx
eCl@ss 4.1	27260701

Base strip - MCVK 1,5/15-G-3,81 - 1832866

Classifications

eCl@ss

eCl@ss 5.0	27260701
eCl@ss 5.1	27260701
eCl@ss 6.0	27260704
eCl@ss 7.0	27440402
eCl@ss 8.0	27141106
eCl@ss 9.0	27141106

ETIM

ETIM 3.0	EC001121
ETIM 4.0	EC002637
ETIM 5.0	EC001284

UNSPSC

UNSPSC 6.01	30211810
UNSPSC 7.0901	39121409
UNSPSC 11	39121409
UNSPSC 12.01	39121409
UNSPSC 13.2	39121409

Approvals

Approvals

Approvals

CSA / EAC / cULus Recognized / EAC

Ex Approvals

Approvals submitted

Approval details

Base strip - MCVK 1,5/15-G-3,81 - 1832866

Approvals

CSA	
	B
mm ² /AWG/kcmil	28-16
Nominal current IN	8 A
Nominal voltage UN	300 V

EAC

cULus Recognized	
	B
mm ² /AWG/kcmil	30-14
Nominal current IN	8 A
Nominal voltage UN	300 V

EAC

Accessories

Accessories

Coding element

Coding profile - CP-MSTB - 1734634

Coding profile, is inserted into the slot on the plug or inverted header, red insulating material



Labeled terminal marker

Marker card - SK 3,81/2,8:FORTL.ZAHLEN - 0804109



Marker card, Card, white, labeled, Horizontal: Consecutive numbers 1 - 10, 11 - 20, etc. up to 91 - (99)100, Mounting type: Adhesive, for terminal block width: 3.81 mm, Lettering field: 3.81 x 2.8 mm

Base strip - MCVK 1,5/15-G-3,81 - 1832866

Accessories

Screwdriver tools

Screwdriver - SZS 0,4X2,5 VDE - 1205037



Screwdriver, slot-headed, VDE insulated, size: 0.4 x 2.5 x 80 mm, 2-component grip, with non-slip grip

Additional products

Printed-circuit board connector - MCVW 1,5/15-ST-3,81 - 1827101



Plug component, Nominal current: 8 A, Rated voltage (III/2): 160 V, Number of positions: 15, Pitch: 3.81 mm, Connection method: Screw connection with tension sleeve, Color: green, Contact surface: Tin

Printed-circuit board connector - FK-MCP 1,5/15-ST-3,81 - 1851177

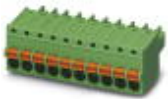

Plug component, Nominal current: 8 A, Rated voltage (III/2): 160 V, Number of positions: 15, Pitch: 3.81 mm, Connection method: Push-in spring connection, Color: green, Contact surface: Tin

Printed-circuit board connector - FRONT-MC 1,5/15-ST-3,81 - 1850796



Plug component, Nominal current: 8 A, Rated voltage (III/2): 160 V, Number of positions: 15, Pitch: 3.81 mm, Connection method: Front screw connection, Color: green, Contact surface: Tin

Printed-circuit board connector - MCC 1/15-STZ-3,81 - 1852309



Plug component, Nominal current: 8 A, Rated voltage (III/2): 160 V, Number of positions: 15, Pitch: 3.81 mm, Connection method: Crimp connection, Color: green, Corresponding female crimp contacts with current [A] and conductor cross section range [mm²] data: 5A/MCC-MT 0,2-0,35 (1859988); 8A/MCC-MT 0,5-1,0 (1859991)

Base strip - MCVK 1,5/15-G-3,81 - 1832866

Accessories

Printed-circuit board connector - QC 0,5/15-ST-3,81 - 1897526

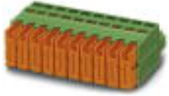

Plug component, Nominal current: 6 A, Rated voltage (III/2): 200 V, Number of positions: 15, Pitch: 3.81 mm, Connection method: Displacement connection, Color: green, Contact surface: Tin

Base strip - IMCV 1,5/15-G-3,81 - 1875551



Header, Nominal current: 8 A, Rated voltage (III/2): 160 V, Number of positions: 15, Pitch: 3.81 mm, Color: green, Contact surface: Tin, Mounting: Wave soldering

Base strip - IMC 1,5/15-G-3,81 - 1862700



Header, Nominal current: 8 A, Rated voltage (III/2): 160 V, Number of positions: 15, Pitch: 3.81 mm, Color: green, Contact surface: Tin, Mounting: Wave soldering

Printed-circuit board connector - MCVR 1,5/15-ST-3,81 - 1827253



Plug component, Nominal current: 8 A, Rated voltage (III/2): 160 V, Number of positions: 15, Pitch: 3.81 mm, Connection method: Screw connection with tension sleeve, Color: green, Contact surface: Tin

Printed-circuit board connector - MC 1,5/15-ST-3,81 - 1803701



Plug component, Nominal current: 8 A, Rated voltage (III/2): 160 V, Number of positions: 15, Pitch: 3.81 mm, Connection method: Screw connection with tension sleeve, Color: green, Contact surface: Tin

Base strip - MCVK 1,5/15-G-3,81 - 1832866

Drawings

Dimensional drawing

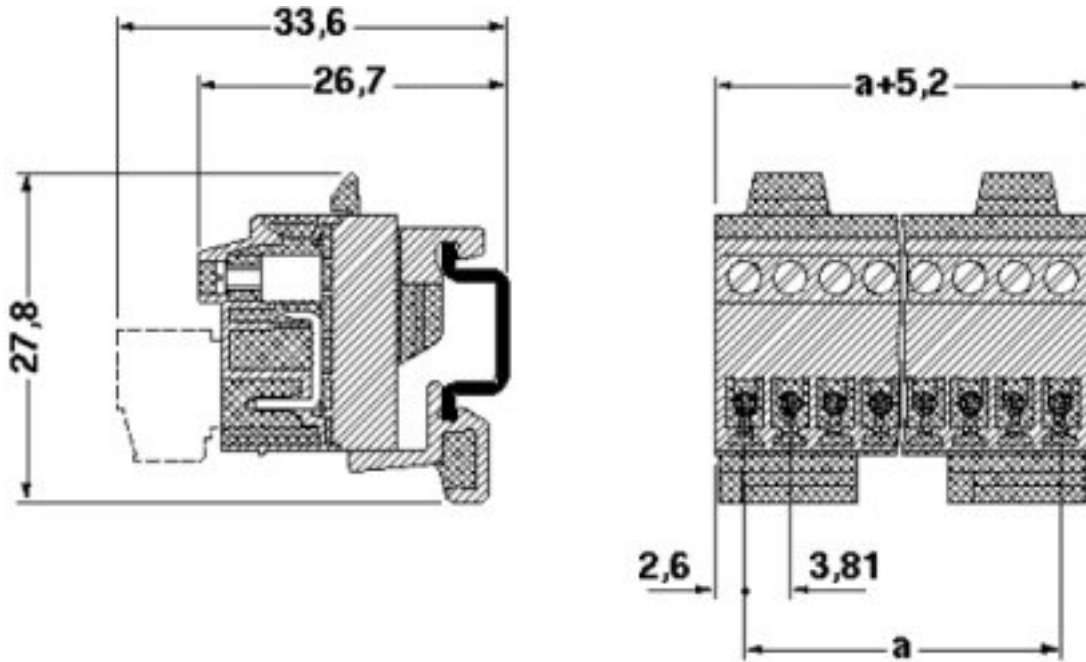

Компания «Life Electronics» занимается поставками электронных компонентов импортного и отечественного производства от производителей и со складов крупных дистрибьюторов Европы, Америки и Азии.

С конца 2013 года компания активно расширяет линейку поставок компонентов по направлению коаксиальный кабель, кварцевые генераторы и конденсаторы (керамические, пленочные, электролитические), за счёт заключения дистрибьюторских договоров

Мы предлагаем:

- Конкурентоспособные цены и скидки постоянным клиентам.
- Специальные условия для постоянных клиентов.
- Подбор аналогов.
- Поставку компонентов в любых объемах, удовлетворяющих вашим потребностям.
- Приемлемые сроки поставки, возможна ускоренная поставка.
- Доставку товара в любую точку России и стран СНГ.
- Комплексную поставку.
- Работу по проектам и поставку образцов.
- Формирование склада под заказчика.
- Сертификаты соответствия на поставляемую продукцию (по желанию клиента).
- Тестирование поставляемой продукции.
- Поставку компонентов, требующих военную и космическую приемку.
- Входной контроль качества.
- Наличие сертификата ISO.

В составе нашей компании организован Конструкторский отдел, призванный помогать разработчикам, и инженерам.

Конструкторский отдел помогает осуществить:

- Регистрацию проекта у производителя компонентов.
- Техническую поддержку проекта.
- Защиту от снятия компонента с производства.
- Оценку стоимости проекта по компонентам.
- Изготовление тестовой платы монтаж и пусконаладочные работы.



Тел: +7 (812) 336 43 04 (многоканальный)

Email: org@lifeelectronics.ru