

## Product Specification

### 2.125 Gb/s RoHS Compliant Short Wavelength 2x5 SFF Transceiver

#### FTLF8519F2xTL

#### PRODUCT FEATURES

- Up to 2.125 Gb/s bi-directional data links
- Standard 2x5 pin SFF footprint (MSA compliant)
- 850nm Oxide VCSEL laser transmitter
- Duplex LC connector
- RoHS compliant and Lead Free
- Up to 500m on 50/125µm MMF, 300m on 62.5/125µm MMF
- Metal enclosure, for lower EMI
- Single 3.3V power supply
- Low power dissipation <750mW
- Industrial operating temperature range: -40°C to 85°C



#### APPLICATIONS

- 1.25 Gb/s 1000Base-SX Ethernet
- Dual Rate 1.063/2.125 Gb/s Fibre Channel

Finisar's FTLF8519F2xTL Small Form Factor (SFF) transceivers comply with the 2x5 standard package defined by the Small Form Factor Multi-Sourcing Agreement (MSA)<sup>1</sup>. They are simultaneously compatible with Gigabit Ethernet as specified in IEEE Std 802.3<sup>2</sup> and Fibre Channel FC- PI-2 Rev. 7.0<sup>3</sup>. They are RoHS compliant and lead-free per Directive 2002/95/EC<sup>4</sup> and Finisar Application Note AN-2038.

#### PRODUCT SELECTION

### FTLF8519F2xTL

x	G	2 Grounding Pins, Short EMI shield
	M	6 Grounding Pins, Short EMI shield
	K	2 Grounding Pins, Long EMI shield
	H	6 Grounding Pins, Long EMI shield

**I. Pin Descriptions**

Pin	Symbol	Name/Description	Logic Family
MS	MS	Mounting Studs are for mechanical attachment and are connected to chassis ground. <b>Chassis ground is internally isolated from circuit grounds.</b> Connection to user's ground plane is recommended.	NA
1	V <sub>EER</sub>	Receiver Ground (Common with Transmitter Ground)	NA
2	V <sub>CCR</sub>	Receiver Power Supply	NA
3	SD	Signal Detect. Logic 1 indicates normal operation.	LVTTL
4	RD-	Receiver Inverted DATA out. AC Coupled	See Rx spec.
5	RD+	Receiver Non-inverted DATA out. AC Coupled	See Rx spec.
6	V <sub>CCT</sub>	Transmitter Power Supply	NA
7	V <sub>EET</sub>	Transmitter Ground (Common with Receiver Ground)	NA
8	T <sub>DIS</sub>	Transmitter Disable	LVTTL
9	TD+	Transmitter Non-Inverted DATA in. AC Coupled.	See Tx spec.
10	TD-	Transmitter Inverted DATA in. AC Coupled	See Tx spec.

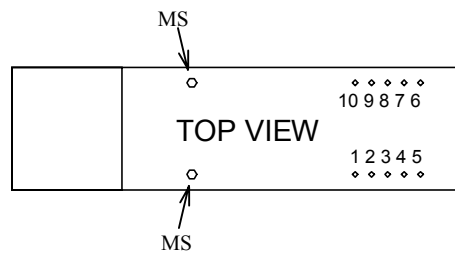
**II. Absolute Maximum Ratings**

Parameter	Symbol	Min	Typ	Max	Unit	Ref.
Maximum Supply Voltage	V <sub>CC</sub>	-0.5		4.0	V	
Storage Temperature	T <sub>S</sub>	-40		85	°C	
Case Operating Temperature	T <sub>OP</sub>	-40		85	°C	
Relative Humidity	RH	0		85	%	1
Hand Lead Soldering Temperature/Time				260/10	°C/s	
Wave Lead Soldering Temperature/Time				260/10	°C/s	

Notes:

1. Non condensing.

**III. Electrical Characteristics ( $T_{OP} = -40$  to  $85$  °C,  $V_{CC} = 3.0$  to  $3.6$  Volts)**

Parameter	Symbol	Min	Typ	Max	Unit	Ref.
Supply Voltage	$V_{CC}$	3.0		3.6	V	
Supply Current	$I_{CC}$		180	240	mA	
<b>Transmitter</b>						
Input differential impedance	$R_{in}$		100		$\Omega$	1
Single ended data input swing	$V_{in,pp}$	250		1200	mV	
Transmit Disable Voltage	$V_D$	2		$V_{CC}$	V	
Transmit Enable Voltage	$V_{EN}$	$V_{EE}$		$V_{EE} + 0.8$	V	2
<b>Receiver</b>						
Output differential impedance	$R_{out}$		100		$\Omega$	1
Single ended data output swing	$V_{out,pp}$	250	350	550	mV	3
Data output rise/fall time	$t_r / t_f$			170	ps	4
Mask Margin			45%			
Signal Detect Normal	$SD_{normal}$			$V_{CC_{HOST}}$	V	5
Signal Detect Fault	$SD_{fault}$	$V_{EE}$		$V_{EE} + 0.5$	V	5
Power Supply Rejection	PSR			100	mVpp	6
Deterministic Jitter Contribution (p-p)	$RX \Delta DJ$			51.7	ps	7
Total Jitter Contribution (p-p)	$RX \Delta TJ$			123	ps	8

Notes:

1. AC coupled.
2. Or open circuit.
3. Into  $100 \Omega$  differential termination. Data pattern is PRBS  $2^7-1$ .
4. 20 – 80 %.
5. Signal detect is LVTTTL. Logic 1 indicates normal operation; logic 0 indicates no signal detected.
6. All transceiver specifications are compliant with a power supply sinusoidal modulation of 20 Hz to 1.5 MHz up to specified value applied through the power supply filtering network shown on page 23 of the Small Form-factor Pluggable (SFP) Transceiver MultiSource Agreement (MSA), September 14, 2000<sup>5</sup>.
7. Measured with DJ-free data input signal. In actual application, output DJ will be the sum of input DJ and  $\Delta DJ$ .
8. If measured with TJ-free data input signal. In actual application, output TJ will be given by:

$$TJ_{OUT} = DJ_{IN} + \Delta DJ + \sqrt{(TJ_{IN} - DJ_{IN})^2 + (\Delta TJ - \Delta DJ)^2}$$

**IV. Optical Characteristics (T<sub>OP</sub> = -40 to 85 °C, V<sub>CC</sub> = 3.0 to 3.6 Volts)**

Parameter	Symbol	Min	Typ	Max	Unit	Ref.
<b>Transmitter</b>						
Output Opt. Pwr: 50 or 62.5 MMF	P <sub>OUT</sub>	-9		-2.5	dBm	1
Optical Wavelength	λ	830		860	nm	
Spectral Width	σ			0.85	nm	
Optical Modulation Amplitude	OMA <sub>Tx</sub>	196			μW	2
Optical Rise/Fall Time	t <sub>r</sub> / t <sub>f</sub>			150	ps	3
Relative Intensity Noise	RIN			-120	dB/Hz	
Deterministic Jitter Contribution (p-p)	TX ΔDJ		20	56.5	ps	4
Total Jitter Contribution (p-p)	TX ΔTJ			119	ps	5
Extinction Ratio @ 1.25 Gb/s	ER	9			dB	
Mask Margin			45%			
<b>Receiver</b>						
Receiver Sensitivity = 1.0625 Gb/s	RX <sub>SENS</sub>			-20	dBm	6
Receiver Sensitivity = 2.125 Gb/s	RX <sub>SENS</sub>			-18	dBm	6
Receiver Sensitivity = 1.25 Gb/s	RX <sub>SENS</sub>			-20	dBm	7
Stressed RX sens. = 1.0625 Gb/s		0.055			mW	8
Stressed RX sens. = 2.125 Gb/s		0.096			mW	8
Stressed RX sens = 1.25 Gb/s				-13.5	dBm	9
Average Received Power	RX <sub>MAX</sub>			0	dBm	
Receiver Elec. 3 dB cutoff freq.				1500	MHz	
Optical Center Wavelength	λ <sub>C</sub>	770		860	nm	
Return Loss	RL	12			dB	
Signal Detect Normal	SD <sub>normal</sub>			-20	dBm	
Signal Detect Fault	SD <sub>fault</sub>	-30			dBm	
Signal Detect Hysteresis		0.5			dB	

Notes:

- Class 1 Laser Safety per FDA/CDRH, EN (IEC) 60825 laser safety regulations.
- Equivalent extinction ratio specification for Fibre Channel. Allows smaller ER at higher average power.
- Unfiltered, 20-80%. Complies with FC 1x and 2x eye mask when filtered.
- Measured with DJ-free data input signal. In actual application, output DJ will be the sum of input DJ and ΔDJ.
- If measured with TJ-free data input signal. In actual application, output TJ will be given by:

$$TJ_{OUT} = DJ_{IN} + \Delta DJ + \sqrt{(TJ_{IN} - DJ_{IN})^2 + (\Delta TJ - \Delta DJ)^2}$$

- Specifications are for 50 micro-meter or 62.5 micro-meter fiber
- As measured with 9dB extinction ratio.
- Measured with conformance signals defined in FC-PI-2 Rev. 7.0 specifications.
- Measured with conformance signals defined in IEEE 802.3 specifications.

**V. General Specifications**

Parameter	Symbol	Min	Typ	Max	Units	Ref.
Data Rate	BR		1.062, 1.25 2.125		Gb/sec	1
Bit Error Rate	BER			10 <sup>-12</sup>		4
Fiber Length on 50/125µm MMF	L			500 300	m	2 3
Fiber Length on 62.5/125µm MMF	L			300 150	m	2 3

Notes:

1. Gigabit Ethernet and 1x, 2x Fibre Channel compatible per IEEE 802.3 and FC-PI-2 Rev. 7.0 respectively. Typical maximum data rate extends to 2.5Gb/s.
2. At 1.0625 Gb/s Fibre Channel and 1.25 Gb/s Gigabit Ethernet data rates.
3. At 2.125 Gb/s Fibre Channel data rate.
4. At 1.0625, 1.25, and 2.125Gb/s with PRBS 2<sup>7</sup>-1.

**VI. Environmental Specifications**

FTLF8519F2xTL SFF transceivers have an industrial operating temperature range from -40°C to +85°C case temperature.

Parameter	Symbol	Min	Typ	Max	Units	Ref.
Case Operating Temperature	T <sub>op</sub>	-40		85	°C	
Storage Temperature	T <sub>sto</sub>	-40		85	°C	

Notes:

1. SFF transceivers may be water washed. However, the process must be followed by a baking step at 80°C for one hour, to ensure the drying of any water which may be trapped inside then shells of the modules.

**VII. Regulatory Compliance**

Finisar transceivers are Class 1 Laser Products and comply with US FDA regulations. These products are certified by TÜV and CSA to meet the Class 1 eye safety requirements of EN (IEC) 60825 and the electrical safety requirements of EN (IEC) 60950. Copies of certificates are available at Finisar Corporation upon request.

### VIII. Mechanical Specifications

Finisar’s Small Form Factor (SFF) transceivers comply with the standard dimensions defined by the Small Form Factor Multi-Sourcing Agreement (MSA).

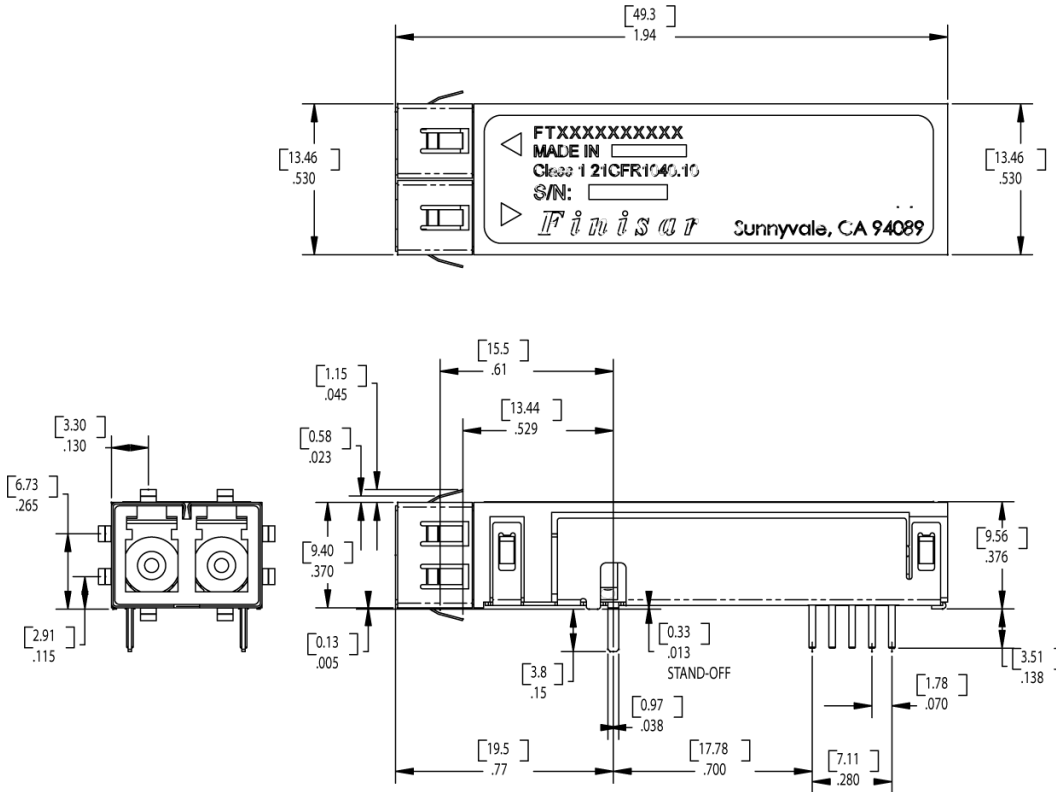

**FTLF8519F2GTL**

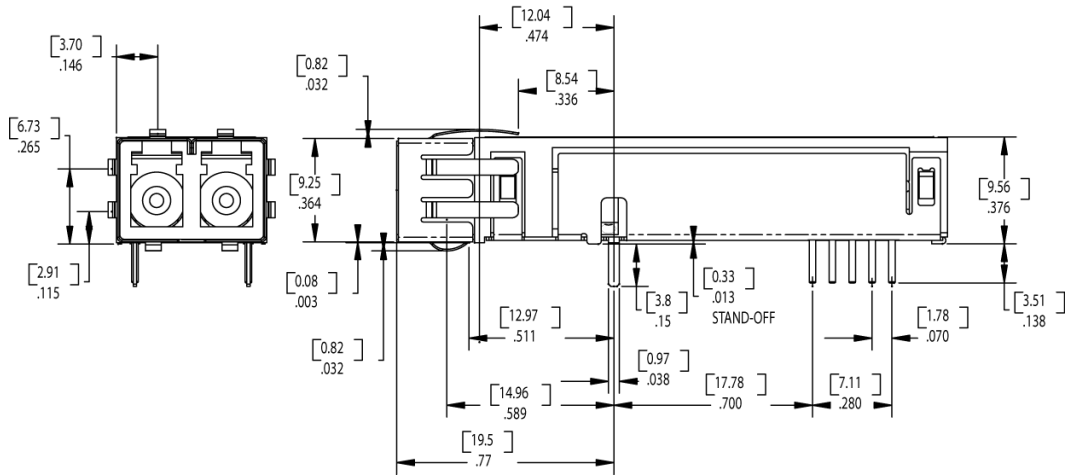
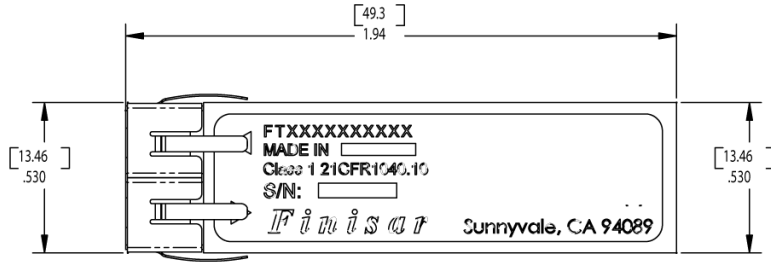

**FTLF8519F2KTL**

**IX. PCB Layout and Bezel Recommendations**

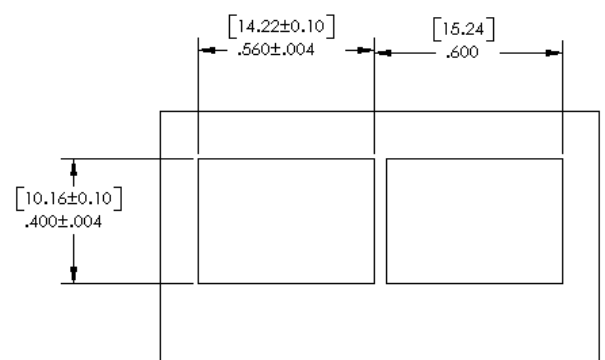
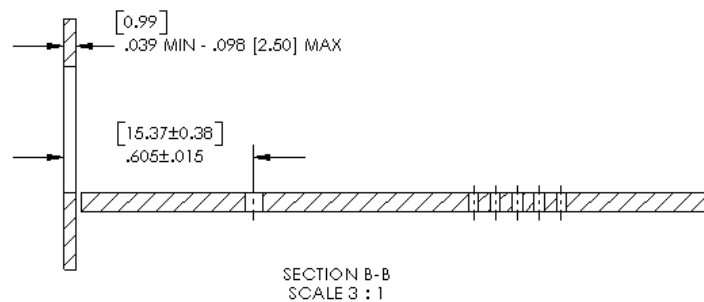
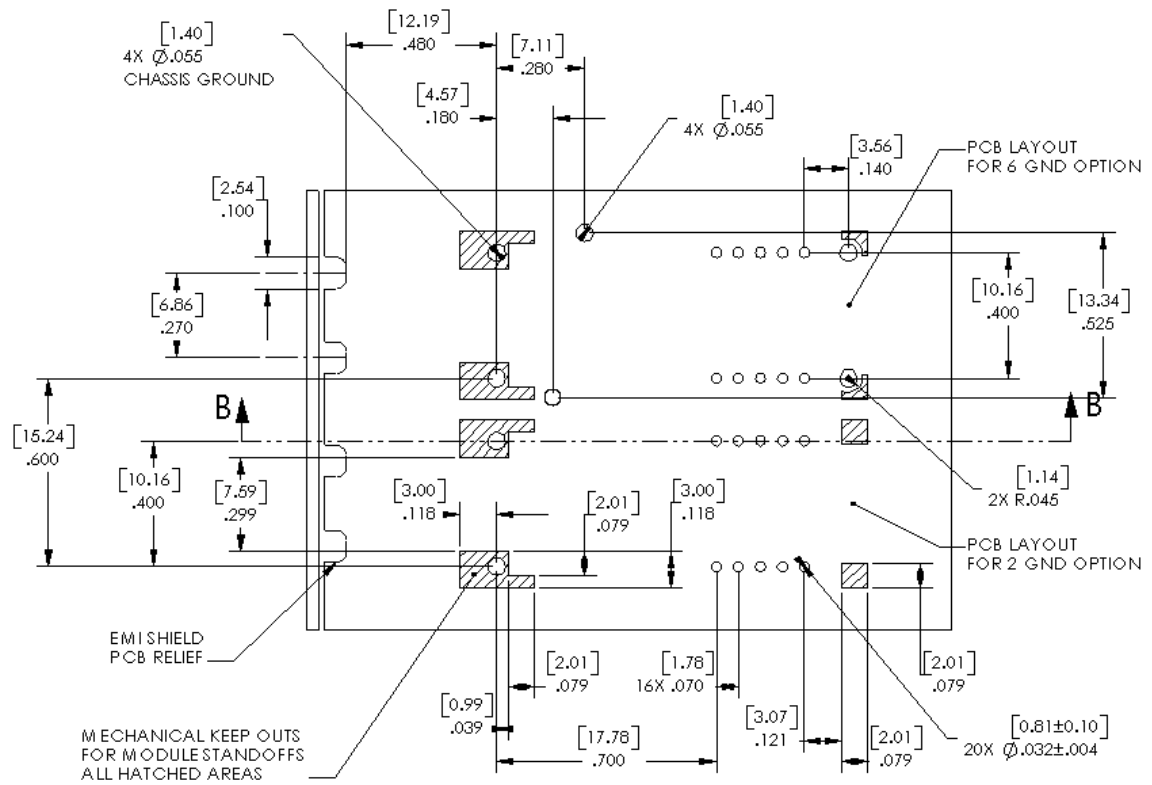

**Minimum Recommended Pitch is 0.600"**



**X. References**

1. Small Form Factor (SFF) Transceiver Multi-source Agreement (MSA). July 5, 2000.
2. IEEE Std 802.3, 2002 Edition, Clause 38, PMD Type 1000BASE-SX.  
IEEE Standards Department, 2002.
3. “Fibre Channel Draft Physical Interface Specification (FC-PI-2 Rev. 7.0)”. American National Standard for Information Systems.
4. Directive 2002/95/EC of the European Council Parliament and of the Council, “on the restriction of the use of certain hazardous substances in electrical and electronic equipment.” January 27, 2003.
5. Small Form-factor Pluggable (SFP) Transceiver Multi-source Agreement (MSA), September 14, 2000.

**XI. For More Information**

Finisar Corporation  
1308 Moffett Park Drive  
Sunnyvale, CA 94089-1133  
Tel. 1-408-548-1000  
Fax 1-408-541-6138  
[sales@finisar.com](mailto:sales@finisar.com)  
[www.finisar.com](http://www.finisar.com)

Компания «Life Electronics» занимается поставками электронных компонентов импортного и отечественного производства от производителей и со складов крупных дистрибьюторов Европы, Америки и Азии.

С конца 2013 года компания активно расширяет линейку поставок компонентов по направлению коаксиальный кабель, кварцевые генераторы и конденсаторы (керамические, пленочные, электролитические), за счёт заключения дистрибьюторских договоров

Мы предлагаем:

- Конкурентоспособные цены и скидки постоянным клиентам.
- Специальные условия для постоянных клиентов.
- Подбор аналогов.
- Поставку компонентов в любых объемах, удовлетворяющих вашим потребностям.
- Приемлемые сроки поставки, возможна ускоренная поставка.
- Доставку товара в любую точку России и стран СНГ.
- Комплексную поставку.
- Работу по проектам и поставку образцов.
- Формирование склада под заказчика.
- Сертификаты соответствия на поставляемую продукцию (по желанию клиента).
- Тестирование поставляемой продукции.
- Поставку компонентов, требующих военную и космическую приемку.
- Входной контроль качества.
- Наличие сертификата ISO.

В составе нашей компании организован Конструкторский отдел, призванный помогать разработчикам, и инженерам.

Конструкторский отдел помогает осуществить:

- Регистрацию проекта у производителя компонентов.
- Техническую поддержку проекта.
- Защиту от снятия компонента с производства.
- Оценку стоимости проекта по компонентам.
- Изготовление тестовой платы монтаж и пусконаладочные работы.



Тел: +7 (812) 336 43 04 (многоканальный)

Email: [org@lifeelectronics.ru](mailto:org@lifeelectronics.ru)