

Miniature Ceramic Resonator



AWSCR-CELA

3.2 x 1.3 x 1.0 mm

RoHS/RoHS II Compliant

Pb in ceramic, exemption (7c-1)

This product is not Moisture Sensitive - MSL = 1

Features

- Industry standard footprint
- Low resonance impedance
- Built-in capacitance options
- Wide operating temperatures in extended industry range

Applications

- Metering systems
- Remote control
- Microprocessor
- Industrial control
- Electric appliances

Electrical Specifications

Parameters	Min	Typ.	Max	Units	Notes
Frequency Range	8.00		12.00	MHz	
Resonant Impedance (Ro)		40		Ω	8.00 MHz - 12.00 MHz
Standard Built-in Capacitance (C1=C2)		15		pF	8.00 MHz - 12.00 MHz (Tol 1pF \pm 20%)
	Other options: 10, 22, 30, 33				
Frequency Tolerance	-0.5		0.5	%	
Temperature Coefficient of Oscillation Frequency (%) max.	-0.2		0.2	%	Oscillator Frequency drift (-40 °C to +85 °C)
Withstanding Voltage			50	V	DC, 1 min max
Voltage Rating	(1) D.C. Voltage		6	V	
	(2) A.C. Voltage		15	Vp-p	
Insulation Resistance (Ri)	500			M Ω	10V, 1 min
Operation Temperature	-40		+85	°C	
Storage Temperature	-55		+85	°C	
Aging Rate max (Fosc) * For 10 years	-0.2		0.2	%	From Initial value

* Components shall be left in a chamber of +85 °C \pm 2 °C for 1000 hours, then measured after leaving in natural condition for 1 hour.

Miniature Ceramic Resonator



AWSCR-CELA

3.2 x 1.3 x 1.0 mm

RoHS/RoHS II Compliant

Pb in ceramic, exemption (7c-I)

This product is not Moisture Sensitive - MSL = 1

Options and Part Identification

AWSCR - □□.□□ CELA - C□□ - □

Frequency (MHz)	Size (mm)	Frequency Band	Operating Temperature	Built-in Cap	Packaging
8.000 - 12.000	CE = 3.2 x 1.3	L = Lower Band	A = -40 °C to 85 °C	15 pF (Standard) 10/22/30/33 pF (Other)	T3 = 3000 pcs/reel

Test Circuit and Conditions

Parts shall be tested under the condition (Temp: 20 °C ± 15 °C, Humidity: 65 ± 20 % R.H.) unless the standard condition (Temp: 25 °C ± 3 °C, Humidity: 65 ± 10 % R.H.) is regulated to measure.

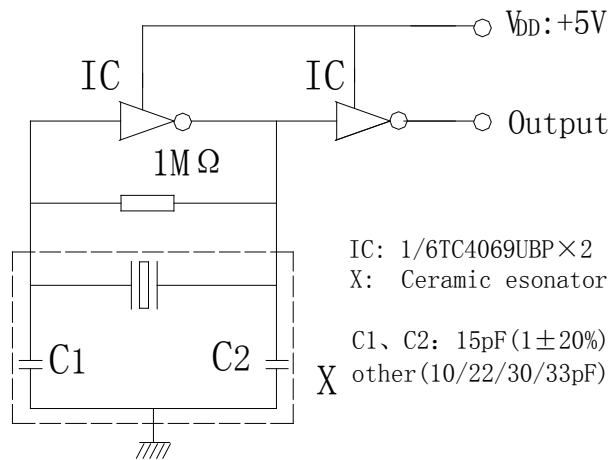

Miniature Ceramic Resonator



AWSCR-CELA

3.2 x 1.3 x 1.0 mm
RoHS/RoHS II Compliant
Pb in ceramic, exemption (7c-1)
This product is not Moisture Sensitive - MSL = 1

Outline Dimensions

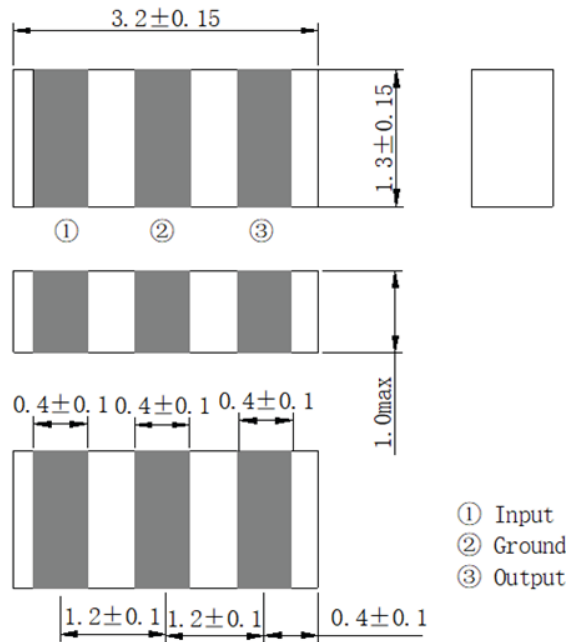

Unit: mm

Miniature Ceramic Resonator



AWSCR-CELA

3.2 x 1.3 x 1.0 mm
RoHS/RoHS II Compliant
Pb in ceramic, exemption (7c-I)
This product is not Moisture Sensitive - MSL = 1

Recommended Land Pattern

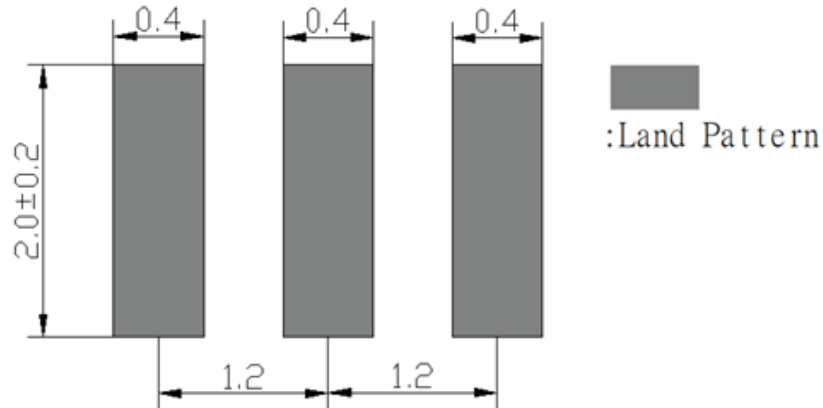

Unit: mm

Recommended Reflow Profile

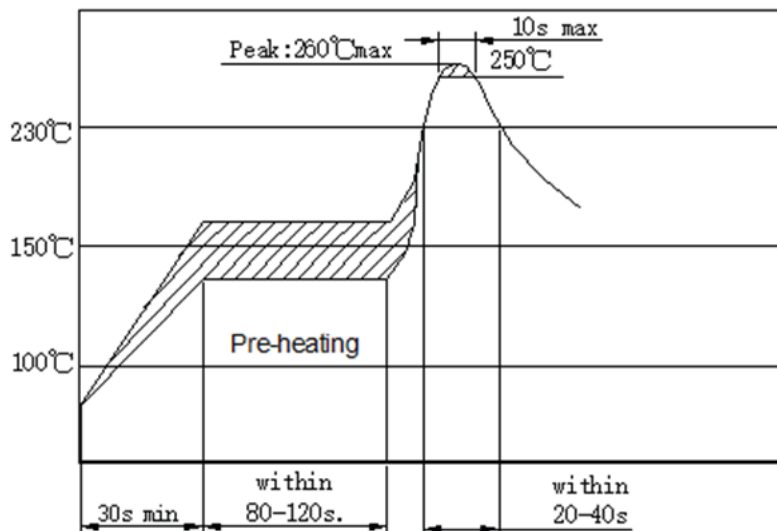

Miniature Ceramic Resonator



AWSCR-CELA

3.2 x 1.3 x 1.0 mm
RoHS/RoHS II Compliant
 Pb in ceramic, exemption (7c-I)
 This product is not Moisture Sensitive - MSL = 1

Packaging

T3: 3000 pcs/reel

Reel Dimension

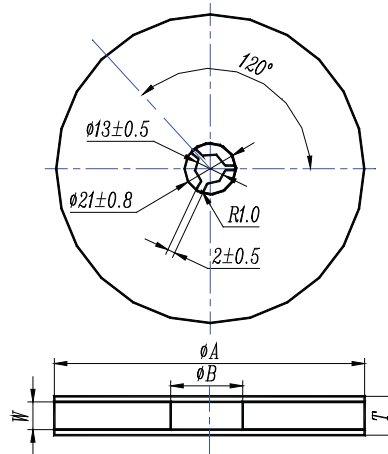

Unit: mm

ϕA	ϕB	W	T	Pieces per reel	Carrier tape size
180 ± 3	60 min	8.4 min	12.4 max	3000 typ.	8

Packaging Sketch

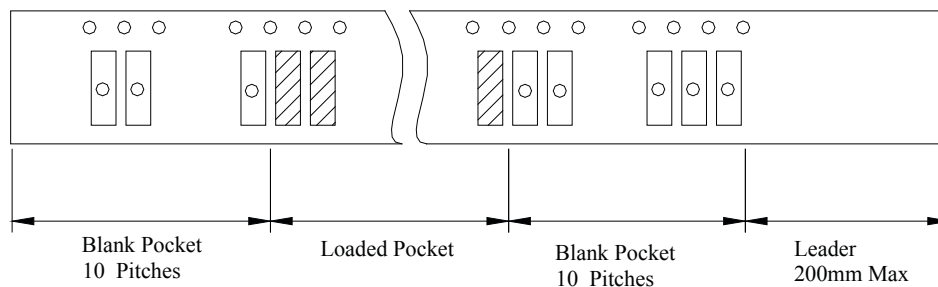

Miniature Ceramic Resonator



AWSCR-CELA

3.2 x 1.3 x 1.0 mm
RoHS/RoHS II Compliant
Pb in ceramic, exemption (7c-1)
This product is not Moisture Sensitive - MSL = 1

Packaging

Test Condition for Peel-Off Strength

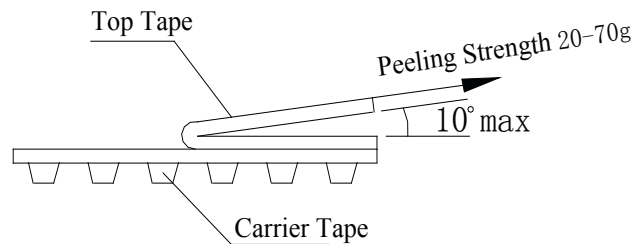

Caution

1. Do not apply excess mechanical stress to the component and terminals during soldering. Do not use this product if it is bent or damaged.
2. Do not clean or wash the component for it is not hermetically sealed.
3. Do not use a strong acidity flux with more than 0.2 wt% chlorine content during soldering.
4. Do not place or use the item close to fire.
5. Please ensure the component is thoroughly evaluated in your application circuit as the specification mentions the quality of the component as a single unit.
6. Expiry date (Shelf life) of the products is 12 months after the date of delivery under the conditions of a sealed and an unopened package. Please use the products within 12 months after delivery. If the item is stored for more than 12 months, use caution before use as the item may be degraded in the solderability or develop rust. Please confirm solderability and characteristics for the products regularly.

ATTENTION: Abracon LLC's products are COTS – Commercial-Off-The-Shelf products; suitable for Commercial, Industrial and, where designated, Automotive Applications. Abracon's products are not specifically designed for Military, Aviation, Aerospace, Life-dependent Medical applications or any application requiring high reliability where component failure could result in loss of life and/or property. For applications requiring high reliability and/or presenting an extreme operating environment, written consent and authorization from Abracon LLC is required. Please contact Abracon LLC for more information.



5101 Hidden Creek Ln Spicewood TX 78669
Phone: 512-371-6159 | Fax: 512-351-8858
For terms and conditions of sales, please visit:
www.abracon.com

REVISED: 04-17-19

ABRACON IS
ISO9001-2015
CERTIFIED

Компания «Life Electronics» занимается поставками электронных компонентов импортного и отечественного производства от производителей и со складов крупных дистрибьюторов Европы, Америки и Азии.

С конца 2013 года компания активно расширяет линейку поставок компонентов по направлению коаксиальный кабель, кварцевые генераторы и конденсаторы (керамические, пленочные, электролитические), за счёт заключения дистрибьюторских договоров

Мы предлагаем:

- Конкурентоспособные цены и скидки постоянным клиентам.
- Специальные условия для постоянных клиентов.
- Подбор аналогов.
- Поставку компонентов в любых объемах, удовлетворяющих вашим потребностям.
- Приемлемые сроки поставки, возможна ускоренная поставка.
- Доставку товара в любую точку России и стран СНГ.
- Комплексную поставку.
- Работу по проектам и поставку образцов.
- Формирование склада под заказчика.
- Сертификаты соответствия на поставляемую продукцию (по желанию клиента).
- Тестирование поставляемой продукции.
- Поставку компонентов, требующих военную и космическую приемку.
- Входной контроль качества.
- Наличие сертификата ISO.

В составе нашей компании организован Конструкторский отдел, призванный помогать разработчикам, и инженерам.

Конструкторский отдел помогает осуществить:

- Регистрацию проекта у производителя компонентов.
- Техническую поддержку проекта.
- Защиту от снятия компонента с производства.
- Оценку стоимости проекта по компонентам.
- Изготовление тестовой платы монтаж и пусконаладочные работы.



Тел: +7 (812) 336 43 04 (многоканальный)
Email: org@lifeelectronics.ru