

## TW2851

### 4-Channel A/V Decoder with Multiplexer/VGA/LCD Display Processor for Security Applications

FN7743  
Rev. 0.00  
August 17, 2012

The TW2851 is a fully integrated A/V decoder, multiplexer, and display processor chip. It has eight CVBS analog inputs fed into four internal high quality NTSC/PAL video decoders. It has four digital input ports supporting various type of input format, including four BT 656 inputs, two BT 601 inputs, or one 1120 playback input. It has one optional VGA display controller or LCD panel controller, two CVBS display, one digital SPOT output, two digital recorder outputs, and one digital display output.

Every output has its associated graphic overlay function that displays bitmap for OSG, single box, 2D array box, borders, privacy mask, and mouse cursor.

The four built-in video decoders include four anti-aliasing filters, 10bit Analog-to-Digital converters, proprietary digital gain/clamp controller, and high quality Y/C separator to reduce cross-noise. Associated with each video decoder, there are built-in motion, blind, and night detectors to provide alarm signals, a noise reducer to reduce the impulse noise, and 3 sets of downscalers to provide proper video size into the display, record, and SPOT multiplexers.

The TW2851 MUX function selects video inputs from any video decoder/ digital inputs to any of recording / SPOT / VGA display / CVBS display outputs flexibly. The recording multiplexer supports frame / field and byte-interleaved multi-channel video streams in the format of BT 656, BT 1120 to interface with external video compression CODEC. The frame / field allocation of each channel can be flexibly configurable in the multi-channel video stream. The multi-channel video stream features built-in channel ID to identify channels of interest for the CODEC or playback module to properly demultiplex the multi-channel stream into single channel streams. The motion / night / blind detection information are also embedded as part of the channel ID.

The display multiplexer displays up to 8 video windows, with 4 for video decoders and 4 for either digital interface or video decoder interface to support pseudo 8 channel inputs. The location and size of each of the 8 display windows are flexibly configurable. The multiplexed display video is sent

to both VGA / LCD and the CVBS output simultaneously. Before the VGA / LCD output, there is a 2D de-interlacer converting the interlaced video into progressive for any PC monitor / LCD panel with resolution up to WXGA+ (1440x900) resolution. The VGA interface provides RGB component with both analog output through 3 embedded DACs and digital TTL outputs. The LVDS interface provides single or dual channel output to drive various TFT LCD panels.

The SPOT multiplexer functions as either SPOT display or a secondary record mux. It supports single D1 frame rate output. When used as display purpose, it is capable of supporting 1 / 4 windows in a fixed configuration. When used as record mux purpose, it is capable of supporting quad window or frame / field interleave multi-channel stream in single D1 frame rate.

There are two built-in video encoders features two 10-bit embedded DACs to provide 2 CVBS outputs. The two video encoders are flexibly configurable to output any two of the display, SPOT and record path video content.

The TW2851 also includes an audio CODEC with five audio Analog-to-Digital converters and one Digital-to-Analog converter. A built-in audio multiplexer generates digital outputs for recording / mixing and accepts digital input for playback.

TW2851 features a cascade function to allow up to 4 TW2851 chips to connect together to increase the total number of channels / windows supported in VGA display and SPOT display. With 4 chips cascaded together, the VGA display path can display up to 32 display windows, and the SPOT display can display up to 16 windows.

### Analog Video Decoder

- 4 sets of video decoder accept all NTSC(M/N/4.43) / PAL (B/D/G/H/I/K/L/M/N/60) standards with auto detection
- 8 CVBS analog inputs for pseudo 8 channel support
- Integrated video analog anti-aliasing filters and 10 bit CMOS ADCs for each video decoder

- High performance adaptive 4H comb filters for all NTSC/PAL standards
- IF compensation filter for improvement of color demodulation
- Color Transient Improvement (CTI)
- Automatic white peak control
- Triple high performance scalers scale video input independently for each of display, recording and SPOT path
- Four built-in motion detectors with 16 X 12 cells, four blind and night detectors

## Digital Input Ports

- Supports up to 4 BT. 656 ports, 2 BT. 601, 1 port RGB, or 1 port BT. 1120. The BT 1120 supports a 54 MHz channel with 4 D1 put together.
- Auto cropping / strobe for playback input using 2 built-in Analog / Digital Channel ID decoder for selecting 4 out of maximum of 16 channels from multi-channel input stream
- 4 built-in down scalers for displaying arbitrary size windows on the display output

## Analog/Digital VGA Display

- Native Resolution of VGA, D1, SVGA, XGA, up to WXGA+ (1440x900), capable of displaying 4 D1 screens side by side without downscaling.
- Up-Scaler for ZOOM function and playback of full screen D1 image
- 3 Built-in DACs for analog VGA RGB output
- Digital RGB interface in 24-bit TTL output
- DDC channel interface to read the external monitor configuration
- Built-in 2D De-interlacer for progressive output
- Sharpness control with horizontal/vertical peaking
- Black/White Stretch
- Programmable hue, brightness, saturation, contrast
- Independent RGB gain and offset controls
- Programmable Gamma correction for each of RGB
- Built-in 2-layer 9-window bitmap OSG with 16-bit per pixel color
- Hardware OSG bitmap up-scaler to allow same content displayed on both VGA/LCD and CVBS output
- Additional OSG layers such as window border box, 2D motion box, Privacy Mask overlay, and Mouse Cursor support

- Programmable hue, saturation, contrast, brightness and sharpness
- Proprietary fast video locking system for non-real-time application
- Noise Reduction to remove impulse noise

## TFT LCD Panel Support

- Supports panel with similar resolution as the VGA port
- Supports single or dual channel LVDS panel
- Supports Panel power sequencing.
- Supports DPMS for monitor power management

## Display CVBS Output

- Display Output through one of the two built-in CVBS video encoder
- Built-in 2-layer 9-windows bitmap OSG with 16-bit per pixel color
- Additional OSG layers such as window border box, 2D motion box, mouse cursor, and Privacy Mask overlay

## Display Multiplexer

- Displays 8 windows for 4 video decoder inputs plus 4 digital input channels or 8 video decoder channels to support pseudo 8-channel
- Either Live or Strobe capture mode for pseudo 8-channel support
- Horizontal / Vertical mirroring for each window
- Last field / frame image captured when video-loss detected
- Simultaneous output to both VGA/LCD and CVBS output with the same video content

## Record Multiplexer

- 2 ports of BT. 656, 1 port BT. 601, or 1 port of BT.1120-like digital Interface support up to 4 D1 real-time recording output to external CODEC
- Supports Frame/Field Interleaved mode with 8 picture types or byte interleaved stream for multi-channel video output
- Either Live or Strobe capture mode for pseudo 8-channel support
- Supports dynamic field / frame picture-type and channel allocation through a switching queue up to 2048 entries
- Horizontal / Vertical mirroring for each window
- 2 Built-in channel ID encoder carrying channel and motion / blind / night detection information of each field/frame in multi-channel stream

- Two built-in 8-window bitmap OSG with 16-bit per pixel color for each of the two record output ports
- Field switching capable OSG supports 4 different contents changing from field to field through switching queue
- Additional OSG layers such Privacy Mask overlay, and Mouse Cursor

## SPOT Multiplexer

- Optionally configured as network output mode through a BT. 656 digital interface to support frame/field interleave feature similar to record path Switch mode
- SPOT analog output configurable through one of the two built-in CVBS video encoder
- LIVE capture mode in FULL D1, Quad CIF and 16 QCIF windows
- Strobe capture mode for pseudo 8-channel support
- Video window arrangement independent of the recording and display output
- Horizontal and Vertical Mirroring for each channel
- Built-in 8 windows bitmap OSGs with 16-bit per pixel color
- Additional OSG layers such as window border box, Privacy Mask overlay, and Mouse Cursor support

## Dual Video Encoders

- Flexibly shared by Display, Record and SPOT
- Analog NTSC/PAL standards
- Programmable bandwidth of luminance and chrominance signal for each path
- Two 10-bit video CMOS DACs

## Cascade Capability

- VGA display cascade mode displays up to 32 windows (16 video input and 16 playback input) on both VGA/LCD and CVBS output using 4 TW2851 chips
- SPOT display cascade support up to 16 channels at the D1 output

- Built-in 8 windows bitmap OSG with 16-bit per pixel color
- Additional OSG layers such as window border box, 2D motion box, mouse cursor, and Privacy Mask overlay

## Audio CODEC

- Integrated five audio ADCs and one audio DAC providing multi-channel audio mixed analog output
- Supports a standard I2S interface for record output and playback input
- PCM 8/16 bit and u-Law/A-Law 8bit for audio word length
- Programmable audio sample rate that covers popular frequencies of 8/16/32/44.1/48kHz

## External DDR SDRAM

- Single centralized external DDR SDRAM of 256 Mb (32 MB) capacity
- 16-bit wide data bus running at 166 MHz
- Auto-refresh

## Host Interface

- MCU parallel interface with 8 / 16 bits data bus and 8 / 12-bit address bus for higher MCU interface throughput
- Supports both address / data separate or multiplexed mode
- Burst write for faster OSG bitmap upload
- Serial I<sup>2</sup>C interface
- PS2 mouse port support

## System Clock

- Single 27 MHz external crystal clock input
- 3 built-in PLLs for internal clock generation

## Package

- 352 BGA

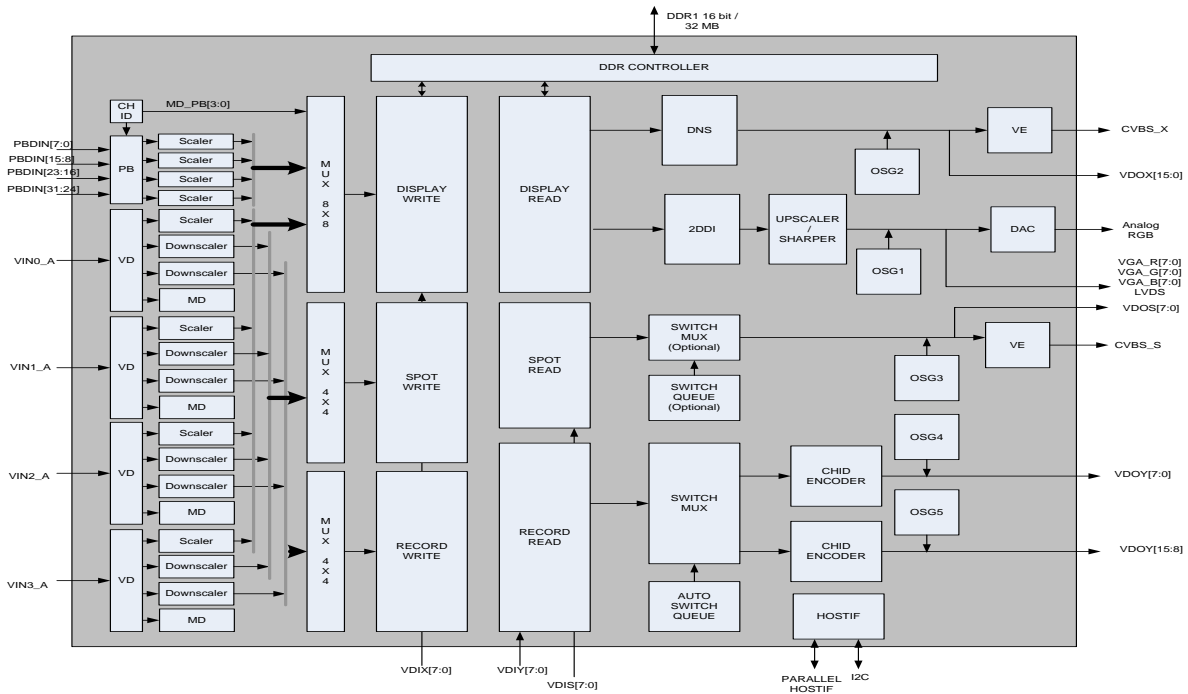

FIGURE 1. TW2851 4-CHANNEL A/V DECODER/MULTIPLEXER/DISPLAY PROCESSOR BLOCK-DIAGRAM

## Ordering Information

PART NUMBER (NOTE 1)	PART MARKING	PACKAGE (PB-FREE)	PKG. DWG. #
TW2851-BB2-GR	TW2851 BB2-GR	352 LEAD BGA (27mmx27mm)	V352.27X27

NOTE:

1. These Intersil Pb-free BGA packaged products employ special Pb-free material sets; molding compounds/die attach materials and SnAg -e2 solder ball terminals, which are RoHS compliant and compatible with both SnPb and Pb-free soldering operations. Intersil Pb-free BGA packaged products are MSL classified at Pb-free peak reflow temperatures that meet or exceed the Pb-free requirements of IPC/JEDEC J STD-020.

# Table of Contents

Analog Video Decoder.....	1	Display Path.....	57
Digital Input Ports.....	2	SPOT Path.....	57
Analog/Digital VGA Display.....	2	<b>Channel ID.....</b>	<b>59</b>
TFT LCD Panel Support.....	2	Channel ID Types.....	59
Display CVBS Output.....	2	Channel ID Encoding Setting.....	61
Display Multiplexer.....	2	Channel ID Decoding Setting.....	62
Record Multiplexer.....	2	Digital Channel ID Format.....	63
SPOT Multiplexer.....	3	<b>OSG.....</b>	<b>66</b>
Dual Video Encoders.....	3	Video Border Layer.....	66
Cascade Capability.....	3	2-Dimensional Arrayed Box.....	67
Audio CODEC.....	3	Bitmap Layer.....	68
External DDR SDRAM.....	3	Single Box.....	71
Host Interface.....	3	Mouse Pointer.....	71
System Clock.....	3	<b>Audio Codec.....</b>	<b>73</b>
Package.....	3	Audio Clock Master/Slave mode.....	74
<b>Ordering Information.....</b>	<b>4</b>	Audio Detection.....	75
Table of Contents.....	5	Audio Multi-Chip Cascade.....	75
Table of Figures.....	7	Serial Audio Interface.....	78
Table List.....	9	Audio Clock Slave Mode Data Output Timing.....	81
Pin Diagram.....	10	ACLKP/ASYNP Slave Mode Data Output Timing.....	82
TW2851 (352 BGA).....	10	Audio Clock Generation.....	84
<b>Pin Descriptions.....</b>	<b>11</b>	Audio Clock Auto Setup.....	86
Analog Interface.....	11	<b>Host Interface.....</b>	<b>87</b>
Digital VGA / LVDS Interface.....	12	Serial Interface.....	89
Host Interface.....	14	Parallel Interface.....	90
Audio Digital Interface.....	15	VGA DDC I2C Master Interface.....	93
Digital Input Interface.....	16	PS2 Mouse Interface.....	94
Digital Output Interface.....	17	Interrupt Interface.....	94
DDR SDRAM Interface.....	18	Burst Interface to DDR SDRAM.....	94
Misc Interface.....	19	<b>External DRAM Interface.....</b>	<b>95</b>
Power / Ground Interface.....	20	<b>Chip Reset / Initiation.....</b>	<b>95</b>
<b>Functional Description.....</b>	<b>22</b>	<b>Frequency Synthesizer Setup.....</b>	<b>96</b>
CVBS Video Input.....	23	<b>Register Description By Function.....</b>	<b>97</b>
Formats.....	23	<b>CVBS Video Input.....</b>	<b>97</b>
Analog Front-End.....	23	Video Decoder.....	97
Decimation Filter.....	24	Internal Pattern Generator.....	120
AGC and Clamping.....	24	Noise Reduction.....	121
Sync Processing.....	25	Downscaler.....	123
Y/C Separation.....	25	Motion / Blind / Night Detection.....	126
Color Decoding.....	25	<b>Digital Input Interface.....</b>	<b>131</b>
Chrominance Processing.....	27	656 / 601 / RGB Port.....	131
Luminance Processing.....	27	CHID Decode / Strobe.....	136
Pseudo 8 Channels.....	28	Playback Cropping.....	144
Cropping Function.....	28	Playback Downscalers.....	146
Noise Reduction.....	29	<b>Video Multiplexers.....</b>	<b>147</b>
Downscalers.....	29	Record Control.....	147
Motion Detection.....	29	Record Switch Queue.....	150
Blind Detection.....	33	Record CHID Encoder.....	152
Night Detection.....	34	Display Control.....	154
<b>Digital Video Input.....</b>	<b>34</b>	SPOT Control.....	161
ITU-R BT. 656 Digital Video Input Format.....	34	SPOT Switch Queue.....	164
ITU-R BT. 601 Digital Video Input Format.....	36	SPOT CHID Encoder.....	166
ITU-R BT. 1120 Digital Video Input Format.....	36	<b>Display CVBS Processing.....</b>	<b>169</b>
Multi-Channel Video Format.....	36	Down-Scaling.....	169
Playback Input Channel De-multiplexer.....	38	<b>Display VGA / LCD Processing.....</b>	<b>171</b>
Channel ID Decoder.....	40	Up-Scaling.....	174
Cropping and Scaling Function.....	40	Gamma Table.....	175
<b>Video Multiplexers.....</b>	<b>41</b>	2D De-interface.....	175
Capture Control.....	41	Image Enhancement.....	176
Read Control.....	43	<b>Video Output.....</b>	<b>179</b>
Window Configuration.....	46	Record CVBS Timing.....	179
Video Window Control.....	46	SPOT CVBS Timing.....	180
Image Enhancement Processing.....	47	Display CVBS Timing.....	181
<b>Video Output.....</b>	<b>49</b>	CVBS Encoder Control.....	183
Analog VGA/RGB Video Output.....	49	Display Cascade Timing.....	186
CVBS Video Output.....	49	Display VGA Timing.....	189
Digital Output.....	53	TFT Panel Control.....	190
TFT Panel Support.....	56	<b>OSG.....</b>	<b>194</b>
<b>Video Cascade.....</b>	<b>56</b>	OSG Bitmap Write / Move.....	194

OSD Bitmap Read .....	198	Page 2: 0x200 ~ 0x2FE .....	292
1D Box Control .....	203	Page 3: 0x300 ~ 0x3FE .....	323
2D Box Control .....	208	Page 4: 0x400 ~ 0x4FE .....	328
Cursor Control .....	213	Page 5: 0x500 ~ 0x51F .....	340
<b>Audio CODEC</b> .....	<b>214</b>	Page 6: 0x600 ~ 0x620, 0x640 ~ 0x65F, 0x690 ~ 0x6FE .....	343
<b>Host Interface</b> .....	<b>227</b>	Page 9: 0x9C0 ~ 0x9DF .....	353
VGA DDC Interface Control .....	227	Page M: 0xM21 ~ 0xM3F, 0xM60 ~ 0xM8F, where M = 5 ~ 9 .....	355
PS2 Mouse Interface Control .....	229	Page E : 0xE00 ~ 0xEFE .....	367
Interrupt .....	230	<b>AC Timing</b> .....	<b>373</b>
DDR Burst .....	231	<b>Parametric Information</b> .....	<b>376</b>
<b>DDR Memory Controller</b> .....	<b>232</b>	AC/DC Electrical Parameters .....	376
<b>Misc Control</b> .....	<b>234</b>	<b>Package Outline Drawing</b> .....	<b>379</b>
<b>Register Description By Address</b> .....	<b>240</b>	<b>Life Support Policy</b> .....	<b>380</b>
Page 0: 0x000 ~ 0x0FE .....	240	<b>Revision History</b> .....	<b>380</b>
Page 1: 0x100 ~ 0x1FE .....	275		



## Table of Figures

Figure 1. TW2851 4-Channel A/V Decoder/Multiplexer/Display Processor Block Diagram.....	4
Figure 2. TW2851 Pin Diagram (Bottom View).....	10
Figure 3. TW2851 front-end modules .....	22
Figure 4. The frequency response of the video input anti-aliasing filter.....	24
Figure 5. The characteristic of Decimation Filter .....	24
Figure 6. The characteristics of Luminance Notch Filter for NTSC and PAL.....	26
Figure 7. The characteristics of Chrominance Band-Pass Filter for NTSC and PAL.....	26
Figure 8. The characteristics of Chrominance Low-Pass Filter Curves.....	27
Figure 9. The Characteristic of Luminance Peaking filter .....	28
Figure 10. Motion mask and Detection Cell .....	31
Figure 11. The relationship between current and reference field when MD_REFFLD = "0" .....	32
Figure 12. The relationship between current and reference field when MD_REFFLD = "1" .....	33
Figure 13. Timing diagram of ITU-R BT. 656 format .....	35
Figure 14. The VSYNC/HSYNC Timing in BT. 601 Interface .....	36
Figure 15. Multi-channel Picture Types supported by TW2851 .....	37
Figure 16. Playback Input De-multiplexer .....	39
Figure 17. Block diagram of video controller.....	41
Figure 18. The sequence to change display window configuration .....	46
Figure 19. The video output block diagram .....	49
Figure 20. Horizontal and vertical timing control .....	51
Figure 21. Characteristics of luminance filter.....	52
Figure 22. Characteristics of chrominance Filter .....	52
Figure 23. Example of reconstruction filter .....	53
Figure 24. TW2851 Cascade in Display / SPOT paths .....	56
Figure 25. Cascade in Display path only.....	57
Figure 26. The example of auto channel ID for various record output formats.....	61
Figure 27. The related registers for channel ID encoding.....	62
Figure 28. The related registers for channel ID decoding.....	62
Figure 29. The illustration of the Motion digital channel ID in VBI period.....	64
Figure 30. The illustration of the AUTO/DETECTION/USER digital channel ID in VBI period .....	65
Figure 31. The overlay priority of OSG layers.....	66
Figure 32. The 2D arrayed box in table mode and motion display mode .....	68
Figure 33. Block Diagram of Audio Codec .....	73
Figure 34. Audio Decimation Filter Response .....	74
Figure 35. Recommended Clock Master cascade mode system with ACLKRMAS <sub>TER</sub> = 1; ASYNROEN = 0; PB_MASTER=076	
Figure 36. Recommended Clock Slave Sync Slave cascade mode system with ACLKRMAS <sub>TER</sub> =0; ASYNROEN=1; PB_MASTER=0.....	77
Figure 37. Timing Chart of Serial Audio Interface .....	78
Figure 38. Timing Chart of Multi-channel Audio Record.....	79
Figure 39. Audio Record Falling Edge Triggered Input/Output Timing, ACLKMAS <sub>TER</sub> =0, RM_SYNC=0 .....	81
Figure 40. Audio Record Falling Edge Triggered Input/Output Timing, ACLKMAS <sub>TER</sub> =0, RM_SYNC=1 .....	81
Figure 41. Audio Record Rising Edge Triggered Input Timing, ACLKMAS <sub>TER</sub> =0, RM_SYNC=0, ASTBROEN=1.....	81
Figure 42. Audio Record Rising Edge Triggered Input Timing, ACLKMAS <sub>TER</sub> =0, RM_SYNC=1, ASTBROEN=1.....	82
Figure 43. Audio Playback Falling Edge Triggered Input Timing, RM_SYNC=0, PB_MASTER=0, ADATPDLY=0 .....	82
Figure 44. Audio Playback Falling Edge Triggered Input Timing, RM_SYNC=1, PB_MASTER=0, ADATPDLY=0 .....	82
Figure 45. Audio Playback Falling Edge Triggered Input Timing, RM_SYNC=0, PB_MASTER=0, ADATPDLY=1 .....	82
Figure 46. Audio Playback Falling Edge Triggered Input Timing, RM_SYNC=1, PB_MASTER=0, ADATPDLY=1 .....	83
Figure 47. Audio Playback Rising Edge Triggered Input Timing, RM_SYNC=0, PB_MASTER=0, ADATPDLY=1 .....	83
Figure 48. Audio Playback Rising Edge Triggered Input Timing, RM_SYNC=1, PB_MASTER=0, ADATPDLY=1 .....	83
Figure 49. Audio Playback Rising Edge Triggered Input Timing, RM_SYNC=0, PB_MASTER=0, ADATPDLY=0 .....	83
Figure 50. Audio Playback Rising Edge Triggered Input Timing, RM_SYNC=1, PB_MASTER=0, ADATPDLY=0 .....	84
Figure 51. The serial interface for the case of slave address. (Read : "0x085", Write : "0x084").....	89

---

Figure 52. Write timing of serial interface .....	89
Figure 53. Read timing of serial interface .....	89
Figure 54. Write timing of parallel interface with address/data multiplexing mode .....	90
Figure 55. Read timing of parallel interface with address / data multiplexing mode.....	90
Figure 56. Write timing of parallel interface with separate address / data bus.....	91
Figure 57. Read timing of parallel interface with separate address / data bus.....	92
Figure 58. The window ID of the 16 window configuration .....	168
Figure 59. Cascade Interface Timing Diagram.....	374
Figure 60. Playback Interface Timing Diagram .....	375
Figure 61. Digital Video Output Timing Diagram .....	376



## Table List

Table 1.	Video Input Formats Supported by the TW2851.....	23
Table 2.	ITU-R BT.656 SAV and EAV code sequence.....	35
Table 3.	Playback Input Configurations.....	38
Table 4.	Capture Modes support of display/SPOT/record paths.....	42
Table 5.	Display Channel Configuration.....	43
Table 6.	Switch Queue Entry Definition of Record Path.....	45
Table 7.	Switch Queue Entry Definition of SPOT Path.....	45
Table 8.	Analog output video standards.....	50
Table 9.	Digital Record Output Port Configuration.....	54
Table 10.	ITU-R BT.656 SAV and EAV code sequence.....	55
Table 11.	SP_CC_EN Setting for the Record Path Cascade.....	58
Table 12.	The Detection channel ID information.....	59
Table 13.	Auto channel ID Byte 0 through Byte 3 (For 4 regions).....	60
Table 14.	The Picture Type Code.....	60
Table 15.	Sequence of Multi-channel Audio Record.....	80
Table 16.	Audio frequency 256xfs mode: AIN5MD = 0, AFS384 = 0.....	85
Table 17.	Audio frequency 320xfs mode: AIN5MD = 1, AFS384 = 0, 44.1/48 KHz not supported.....	85
Table 18.	Audio frequency 384xfs mode: AIN5MD = 0, AFS384 = 1, 44.1/48 KHz not supported.....	86
Table 19.	Pin assignments for serial and parallel interface.....	87
Table 20.	Timing parameters of parallel interface with address / data multiplexing mode.....	91
Table 21.	Timing parameters of parallel interface with separate address / data bus.....	92
Table 22.	Cascade Clock Timing Parameters.....	373
Table 23.	Playback Interface Timing Parameters.....	374
Table 24.	Digital Video Output Timing Parameters.....	376
Table 25.	Characteristics.....	376

# Pin Diagram

## TW2851 (352 BGA)

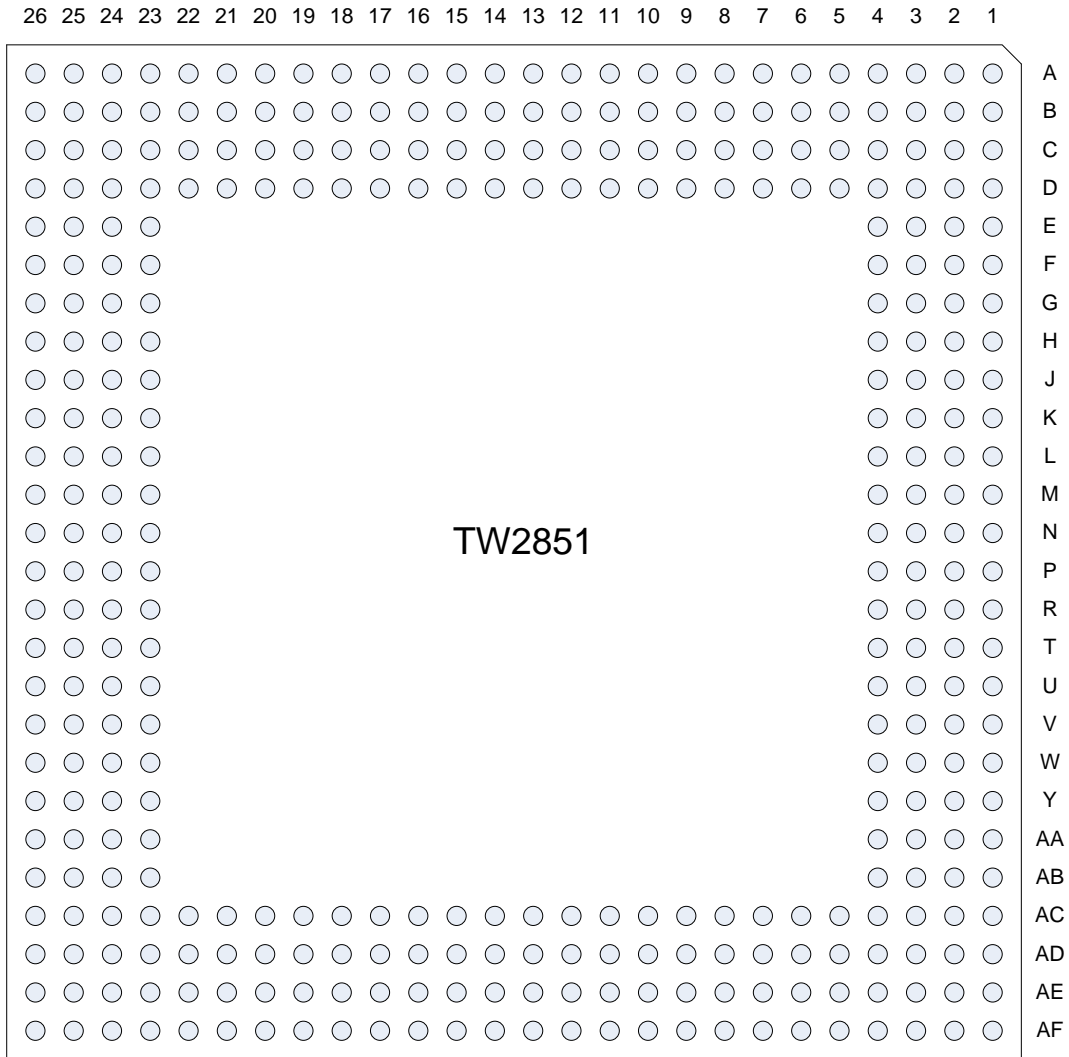

FIGURE 2.TW2851 PIN DIAGRAM (BOTTOM VIEW)

## Pin Descriptions

### Analog Interface

NAME	PIN #	TYPE	DESCRIPTION
VIN1A	M2	A	Composite video input A of channel 1.
VIN1B	M3	A	Composite video input B of channel 1.
VIN2A	N2	A	Composite video input A of channel 2.
VIN2B	N3	A	Composite video input A of channel 2.
VIN3A	P2	A	Composite video input A of channel 3.
VIN3B	P3	A	Composite video input B of channel 3.
VIN4A	R2	A	Composite video input A of channel 4.
VIN4B	R3	A	Composite video input B of channel 4.
AIN1	U2	A	Audio input of channel 1.
AIN2	U3	A	Audio input of channel 2.
AIN3	V1	A	Audio input of channel 3.
AIN4	V2	A	Audio input of channel 4.
AIN5	V3	A	Audio input of channel 5.
AINN	T3	A	AINN
AOUT	T2	A	Audio mixing output.
VAOX	W2	A	Display CVBS analog video output.
VAOS	W3	A	SPOT CVBS analog video output.
VAOXR	AA2	A	Display output R signal
VAOXG	AA3	A	Display output G signal
VAOXB	AB2	A	Display output B signal
RTERM	Y4	A	R Termination

## Digital VGA / LVDS Interface

NAME	PIN #		TYPE	DESCRIPTION
	VGA	LCD		
VGA_VS	AF2	n/a	0	VSYNC for VGA output  This pin is also used as a power up strap pin to determine the data bus width of the parallel host interface. Pull Up: 16 bit mode, Pull Down: 8 bit mode
VGA_HS	AE2	n/a	0	HSYNC for VGA output
VGA_DE	AD2	n/a	I/O	Data Enable bit for VGA / RGB data output
VGA_CLK	AF1	n/a	I/O	Clock output for VDOUTX (27, 54, or up to 106.25 MHz)
DDC_CLK	AC3	n/a	0	DDC channel clock Output low active, otherwise tri-state Need external pull up
DDC_DATA	AC2	n/a	I/O	DDC channel data Output low active, otherwise tri-state Need external pull up
MPP_VDO / VDOX [15:8] / VGA_B[7:0]	AD7, AC8, AD8, AC9, AD9, AC10, AD10, AD11		0	When register 0xEC0 bit [5] is set to 0, these pins are used as VDOX[15:8]. Otherwise these pins are used as VGA B component output.  VDOX[15:8] is used as display data output in 601 Format as Y component for driving external VGA/de-interlacer chips. Depending on the display Resolution, these signals are running from 27MH to 110 MHz
LVDS_A0B / VGA_R[0]	AE14		0	Negative differential LVDS 0 <sup>th</sup> channel data output or VGA Red Color Bit 0
LVDS_A0 / VGA_R[1]	AF14		0	Positive differential LVDS 0 <sup>th</sup> channel data output or VGA Red Color Bit 1
LVDS_A1B / VGA_R[2]	AE13		0	Negative differential LVDS 1 <sup>st</sup> channel data output or VGA Red Color Bit 2
LVDS_A1 / VGA_R[3]	AF13		0	Positive differential LVDS 1 <sup>st</sup> channel data output or VGA Red Color Bit 3
LVDS_A2B / VGA_R[4]	AE12		0	Negative differential LVDS 2 <sup>nd</sup> channel data output or VGA Red Color Bit 4

NAME	PIN #		TYPE	DESCRIPTION
	VGA	LCD		
LVDS_A2 / VGA_R[5]	AF12		0	Positive differential LVDS 2 <sup>nd</sup> channel data output or VGA Red Color Bit 5
LVDS_CK0B	n/a	AE11	0	Negative differential LVDS 0 <sup>th</sup> though 3 <sup>rd</sup> channel clock output
LVDS_CK0	n/a	AF11	0	Positive differential LVDS 0 <sup>th</sup> though 3 <sup>rd</sup> channel clock output
LVDS_A3B VGA_R[6]	AE10		0	Negative differential LVDS 3 <sup>rd</sup> channel data output or VGA Red Color Bit 6
LVDS_A3 / VGA_R[7]	AF10		0	Positive differential LVDS 3 <sup>rd</sup> channel data output or VGA Red Color Bit 7
LVDS_A4B / VGA_G[0]	AE9		0	Negative differential LVDS 4 <sup>th</sup> channel data output or VGA Green Color Bit 0
LVDS_A4 / VGA_G[1]	AF9		0	Positive differential LVDS 4 <sup>th</sup> channel data output or VGA Green Color Bit 1
LVDS_A5B / VGA_G[2]	AE8		0	Negative differential LVDS 5 <sup>th</sup> channel data output or VGA Green Color Bit 2
LVDS_A5 / VGA_G[3]	AF8		0	Positive differential LVDS 5 <sup>th</sup> channel data output or VGA Green Color Bit 3
LVDS_A6B / VGA_G[4]	AF7		0	Negative differential LVDS 6 <sup>th</sup> channel data output or VGA Green Color Bit 4
LVDS_A6 / VGA_G[5]	AE7		0	Positive differential LVDS 6 <sup>th</sup> channel data output or VGA Green Color Bit 5
LVDS_CK1B	n/a	AF6	0	Negative differential LVDS 4 <sup>th</sup> though 7 <sup>th</sup> channel clock output
LVDS_CK1	n/a	AE6	0	Positive differential LVDS 4 <sup>th</sup> though 7 <sup>th</sup> channel clock output
LVDS_A7B / VGA_G[6]	AF5		0	Negative differential LVDS 7 <sup>th</sup> channel data output or VGA Green Color Bit 6
LVDS_A7 / VGA_G[7]	AE5		0	Positive differential LVDS 7 <sup>th</sup> channel data output or VGA Green Color Bit 7
FPPWC	n/a	AD3	0	Power on/off control for flat panel display
FPBIAS	n/a	AE3	0	Panel bias control
FPPWM	n/a	AF3	0	PWM control for panel backlight

## Host Interface

NAME	PIN#	TYPE	DESCRIPTION
HSP[1:0]	B16, D20	I	Host Interface Configuration 00: Address / Data Mux, with ALE high active 01: I2C interface 10: Address / Data Mux, with ALE low active 11: Address Data separate, with 12 bit address
HCSB	E24	I	Parallel Interface: Chip Select signal Serial Interface: Slave address bit 0
HALE / SCLK	D23	I	Address line enable for parallel interface. Serial clock for serial interface / Clock for I2C Bus
HRDB	C21	I	Read enable for parallel interface. VSSO for serial interface.
HWRB	D25	I	Write enable for parallel interface. VSSO for serial interface.
HDAT[6:0]	A24, C25, B25, A25, C26, B26, A26	I/O	Parallel Interface: Data bus bit 6:0 Serial Interface: HDAT[6:1] is slave address bit 6:1
HDAT[7] / SDAT	B24	I/O	Parallel Interface: Data bus bit 7 Serial Interface: Data bit for I2C bus
HDAT[15:8]	B21, A21, B22, A22, B23, A23, D24, C24	I/O	Data bus for parallel interface used in 16-bit data bus mode
HADDR[11:0]	C17, B17, A17, C18, B18, A18, C19, B19, A19, C20, B20, A20	I	The Host Address Bus in Address / Data Separate Mode (HSP == 3'b11)
HWAITB	E25	O	Wait signal to the external MCU. This signal is low active, and tri-state otherwise. Needs external pull-up resistor.
IRQ	C16	O	Interrupt request signal. This signal is low active, and tri-state otherwise. Needs external pull-up resistor.
PS2_CK	E26	I/O	PS2 mouse interface clock signal Output low active, otherwise tri-state. Need external pull up
PS2_D	D26	I/O	PS2 Mouse Interface data signal Output low active, otherwise tri-state. Need external pull up

## Audio Digital Interface

NAME	PIN#	TYPE	DESCRIPTION
ACLKR	AC26	I/O	Audio I2S serial clock input/output of record
ASYNR	AD24	I/O	Audio I2S serial sync input/output of record
ADATR	AB25	O	Audio I2S serial data output of record
ADATM	AD25	O	Audio I2S serial data output of mixing
ACLKP	AD26	I/O	Audio I2S serial clock input/output of playback.
ASYNP	AC24	I/O	Audio I2S serial sync input/output of playback.
ADATP	AB26	I	Audio I2S serial data input of playback.
ALINKO	AC25	O	Link signal for multi-chip connection serial output
ALINKI	D13	I	Link signal for multi-chip connection serial input



## Digital Input Interface

NAME	PIN #	TYPE	DESCRIPTION
PB0_DIN[7:0]	B2, C3, B3, A3, C4, B4, A4, D5	I	Video data of playback port 0 input in BT. 656, Video data of playback port 0 input in BT. 601, or Video data of playback port 0 input in RGB
PB0_CLK	A2	I	Clock of playback input BT 656 port 0
PB1_DIN[7:0]	C2, D2, E2, D3, E3, D4, E4, F4	I	Video data of playback port 1 input in BT. 656, Video data of playback port 0 input in BT. 601, or Video data of playback port 0 input in RGB
PB1_CLK	E1	I	Clock of playback input BT 656 port 1
PB2_DIN[7:0]	H3, H2, G3, G2, G1, F3, F2, F1	I	Video data of playback port 2 input in BT. 656, Video data of playback port 1 input in BT. 601, or Video data of playback port 0 input in RGB
PB2_CLK	H1	I	Clock of playback input BT 656 port 2
PB3_DIN[7:0]	L3, L2, K3, K2, K1, J3, J2, J1	I	Video data of playback port 3 input in BT. 656, Video data of playback port 1 input in BT. 601
PB3_CLK	L1	I	Clock of playback input BT 656 port 3
PB0_VS	B1	I	Playback VSYNC for 601 port 0
PB0_HS	A1	I	Playback HSYNC for 601 port 0
PB1_VS	C1	I	Playback VSYNC for 601 port 1
PB1_HS	D1	I	Playback HSYNC for 601 port 1

## Digital Output Interface

NAME	PIN#	TYPE	DESCRIPTION
VDOX[7:0]	AC12, AD12, AD13, AC14, AD14, AD15, AE15, AF15	O	VDOX[7:0] is used as display data output in 656 or 601 output as U/V components for use as cascade output, or used to drive external VGA/de-interlacer chips. Depending on display output resolution, these signals are running from 27 MHz up to 110 MHz max
CLKOX	AD16	O	CLKOX is used as display clock output
VDIX[7:0]	C5, B5, A5, B6, A6, C7, B7, A7	I	Lower 8 bits of display path cascade input
CLKIX	C6	I	Display path clock input
VDOY [7:0]	AD19, AC19, AF20, AE20, AC20, AF21, AE21, AF22	O	Digital video data output for record path in BT. 656 port 1, or U/V of BT. 601.
VDOY[15:8]	AF16, AE16, AF17, AE17, AF18, AE18, AC18, AF19	O	Digital video data output for record path in BT. 656 port 2 or Y of BT 601.
CLKOY (CLKOY0)	AC21	O	Clock output for record path (27, 54 or 108 MHz)
CLKOYB (CLKOY1)	AE19	O	Clock output for record path 1 (27, 54 or 108 MHz) or the Reverse Clock Output for record path. The CLKOYB signal can be set to the reverse of CLKOY with adjustable delay used for byte interleave record output sampling.
HSOY	AE22	O	HSYNC output if the record output is in ITU-R BT. 601 format
VSOY	AD21	O	VSYSNC output if the record output is in ITU-R BT. 601 format
VDIY[7:0]	C8, B8, A8, C9, B9, A9, B10, A10	I	Lower 8 bits of record path cascade input
CLKIY	D9	I	Record path clock input
VDOS[7:0]	AD22, AC22, AF23, AE23, AF24, AE24, AF25, AE25	O	Digital video data output for SPOT/Network Port
CLKOS	AF26	O	Clock of the SPOT/network output port
VDIS[7:0]	B11, A11, B12, A12, C13, B13, A13, B14	I	SPOT path cascade data input
CLKIS	C11	I	SPOT path cascade clock input

**DDR SDRAM Interface**

NAME	PIN#	TYPE	DESCRIPTION
DQ[15:0]	F26, F25, F24, G26, G24, H26, H24, J26, K26, K24, L26, L25, L24, M26, M25, M24	I/O	DDR DRAM data bus.
ADDR[12:0]	U26, U25, U24, V26, V25, V24, W26, W24, Y26, Y25, Y24, AA26, AA24	0	DDR DRAM address bus
DQS[1:0]	H25, K25	I/O	DDR DRAM Data Strobe
DM[1:0]	J24, N24	0	Byte Mask
BA1	T26	0	DDR DRAM bank1 selection.
BA0	T24	0	DDR DRAM bank0 selection.
RASB	R26	0	DDR DRAM row address selection.
CASB	R25	0	DDR DRAM column address selection.
WEB	P25	0	DDR DRAM write enable.
MCLK	P26	0	DDR DRAM Clock Output
MCLKB	N26	0	DDR DRAM Clock Output
CKE	P24	0	Clock Enable

## Misc Interface

NAME	PIN#	TYPE	DESCRIPTION
EXT_PCLK	A16	I/O	EXT_PCLK pin is used for internal testing only. This pin should be left open
EXT_MCLK	A14	I/O	EXT_MCLK pin is used for internal testing only. This pin should be left open
XTI (27 MHz)	B15	I	Crystal (27 MHz) Clock Input
XTO	A15	O	Crystal Clock Output
TP1	C15	I/O	Test Pin 1. For internal testing only. This pin should be left open.
TEST_EN	J4	I	Test mode enable. For internal use only. Normally tied to 0
RSTB	AB3	I	System reset. Active low.

## Power / Ground Interface

NAME	PIN #	TYPE	DESCRIPTION
VDDO	D7, D12, D22, G4, AB23, AC7, AC13, AC16, AD1, AD6, AD17, AD20	P	Digital power for output driver 3.3V
VDDI	D6, D10, D11, D19, E23, L4, AC1, AC5, AC6, AC17, AE1, AE26, C22	P	Digital power for internal logic 1.2V
VSS	C10, C12, C23, D8, D21, F23, H4, K4, AA4, AB4, AC4, AC11, AC15, AC23, AD4, AD5, AD18, AD23,	G	Core/Pad Ground
VDDVADC0	M1	P	Power for Video ADC0 3.3V
VDDVADC1	N1	P	Power for Video ADC1 3.3V
VDDVADC2	P1	P	Power for Video ADC2 3.3V
VDDVADC3	R1	P	Power for Video ADC3 3.3V
VSSVADC0	M4	G	Ground for Video ADC0
VSSVADC1	N4	G	Ground for Video ADC1
VSSVADC2	P4	G	Ground for Video ADC2
VSSVADC3	R4	G	Ground for Video ADC3
VDDDVDAC	W1	P	Digital power for Video CVBS DACs 3.3V
VDDAVDAC	Y1	P	Analog power for Video CVBS DACs 3.3V
VSSVDAC	V4	G	Digital ground for Video CVBS DACs
VSSAVDAC	W4	G	Analog ground for Video CVBS DACs
VDDARGB	AA1	P	Analog power for RGB DACs 3.3V
VDDDRGB	AB1	P	Digital power for RGB DACs 3.3V
VSSARGB	Y3	G	Analog ground for RGB DACs
VSSDRGB	Y2	G	Digital ground for RGB DACs
VDDAAC	U1	P	Power for Audio ADC 3.3V
VDDADAC	T1	P	Power for Audio DAC 3.3 V
VSSAAC	U4	G	Ground for Audio ADC
VSSADAC	T4	G	Ground for Audio DAC
VDDMPLL	D16	P	Power for Memory Clock PLL +1.2V
VSSMPLL	D15	G	Ground for Memory Clock PLL
VDDPPLL	D17	P	Power for Display Clock PLL +1.2V
VSSPPLL	D18	G	Ground for Display clock PLL

NAME	PIN #	TYPE	DESCRIPTION
VDDSPLL	C14	P	Power Internal 108 MHz clock PLL +3.3V
VSSSPLL	D14	G	Ground Internal 108 MHz clock PLL
VDDDLL	R23	P	DLL Power +1.2V
VSSDLL	R24	G	DLL Ground
VREFSSTL	L23, V23	P	SSTL Reference Voltage (1.25 V)
VSSRSSTL	M23, U23	G	SSTL Reference Ground
VDDPSSTL	G23, H23, K23, N23, T23, W23, AA23	P	SSTL I/O Power +2.5V
VSSPSSTL	G25, J25, N25, W25, AA25	G	SSTL I/O Ground
VDDSSSTL	J23, P23, Y23	P	SSTL Power +1.2V
VSSSSTL	T25, AB24	G	SSTL Ground
LVDDO	AF4	O	LVDS Pad VDD +3.3V
LVSSO	AE4	O	LVDS Pad Ground

# Functional Description

The TW2851 has 12 input interfaces consisting of 8 analog composite video inputs and 4 digital video inputs. The 8 analog video inputs go through 4 analog multiplexers to select 4 out of 8 video inputs to feed to the 4 built-in video decoders. The video decoders feature with 10-bit ADC and luminance/chrominance processor to convert the analog video signal into digital video streams. The four digital inputs for playback application are decoded by internal ITU-R BT656, ITU-R BT601, Component RGB, or ITU-R BT1120 decoders, through the channel ID decoder, and fed to display multiplexer. When using the BT 1120, the playback interface is capable of supporting 4 D1 pictures in one single port.

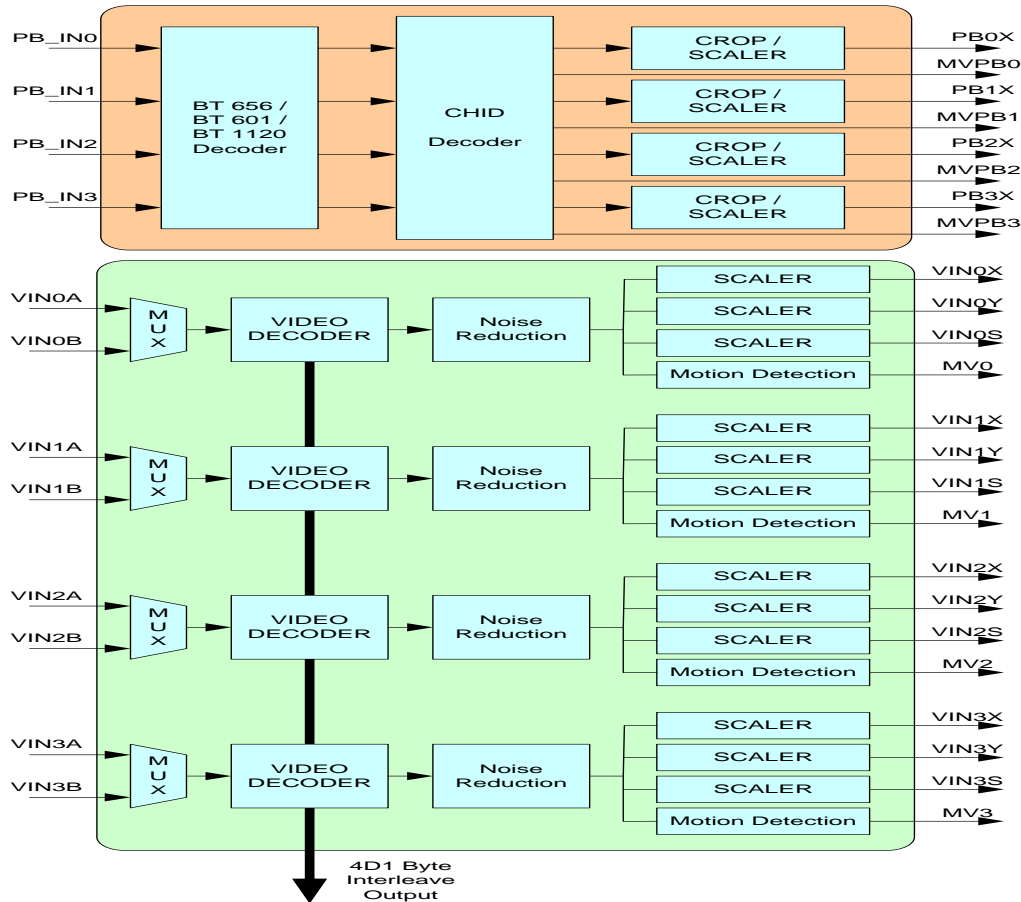

FIGURE 3. TW2851 FRONT-END MODULES

Each built-in video decoder has one motion detector, one noise reduction processor, and three scalars – one for the display path, one for the SPOT path, and one for the record path. The digital video input has four scalars, one for each of the four de-multiplexed video channels. The video input front-end module is shown in Figure 3.



## CVBS Video Input FORMATS

The TW2851 has build-in automatic standard discrimination circuitry. The circuit uses burst-phase, burst-frequency and frame rate to identify NTSC, PAL or SECAM color signals. The standards that can be identified are NTSC (M), NTSC (4.43), PAL (B, D, G, H, I), PAL (M), PAL (N), PAL (60) and SECAM (M). Each standard can be included or excluded in the standard recognition process by software control. The exceptions are the base standard NTSC and PAL, which are always enabled. The identified standard is indicated by the Standard Selection (SDT) register. Automatic standard detection can be overridden by software controlled standard selection.

TW2851 supports all common video formats as shown in Table 1.

TABLE 1. VIDEO INPUT FORMATS SUPPORTED BY THE TW2851

FORMAT	LINES	FIELDS	FSC	COUNTRY
NTSC-M	525	60	3.579545 MHz	U.S., many others
NTSC-Japan <sup>(1)</sup>	525	60	3.579545 MHz	Japan
PAL-B, G, N	625	50	4.433619 MHz	Many
PAL-D	625	50	4.433619 MHz	China
PAL-H	625	50	4.433619 MHz	Belgium
PAL-I	625	50	4.433619 MHz	Great Britain, others
PAL-M	525	60	3.575612 MHz	Brazil
PAL-CN	625	50	3.582056 MHz	Argentina
SECAM	625	50	4.406MHz 4.250MHz	France, Eastern Europe, Middle East, Russia
PAL-60	525	60	4.433619 MHz	China
NTSC (4.43)	525	60	4.433619 MHz	Transcoding

NOTE:

- NTSC-Japan has 0 IRE setup.

The analog front-end converts analog video signals to the required digital format. There are total of 4 analog front-end channels. Every channel contains analog anti-aliasing filter, clamping circuit and 10-bit ADCs. It allows the support of CVBS input signals. Every channel contains the analog clamping circuit, variable gain amplifier and high speed ADCs. It allows three separate inputs to be connected simultaneously. A built-in line locked PLL is used to generate the sampling clock for various inputs.

### ANALOG FRONT-END

The TW2851 contains four 10-bit ADC (Analog to Digital Converters) to digitize the analog video inputs. The ADC can be put into power-down mode by the V\_ADC\_PD (0xEC4) register. The TW2851 also contains an anti-aliasing filter to prevent out-of-band frequency in analog video input signal. Therefore, there is no need for external components in the analog input pin except for an AC coupling capacitor and termination resistor. 0 shows the frequency response of the anti-aliasing filter.

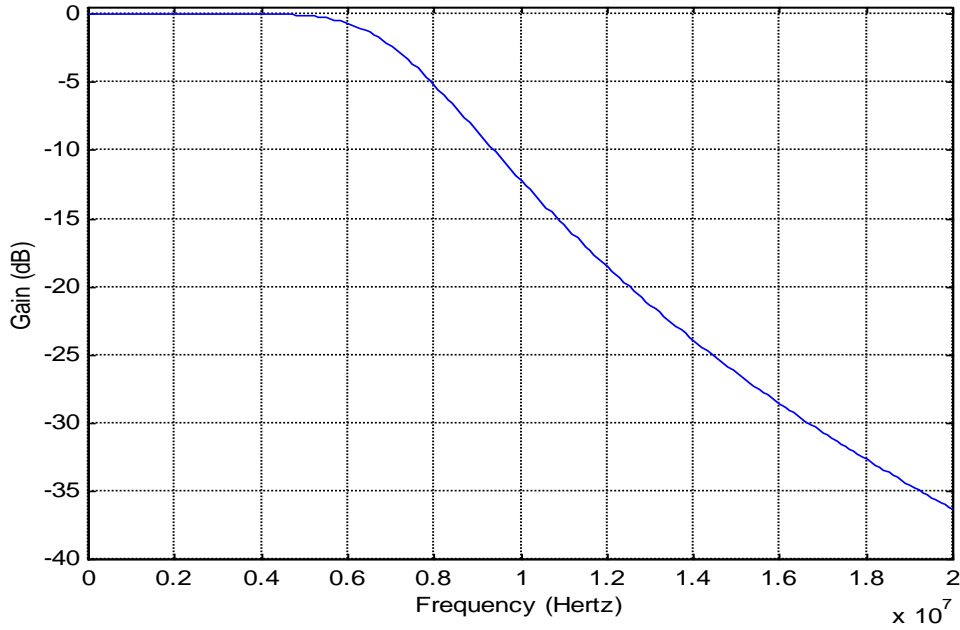

FIGURE 4. THE FREQUENCY RESPONSE OF THE VIDEO INPUT ANTI-ALIASING FILTER

### DECIMATION FILTER

The digitized composite video data are over-sampled to simplify the design of analog filter. The decimation filter is required to achieve optimum performance and prevent high frequency components from being aliased back into the video image when down-sampled. 0 shows the characteristic of the decimation filter.

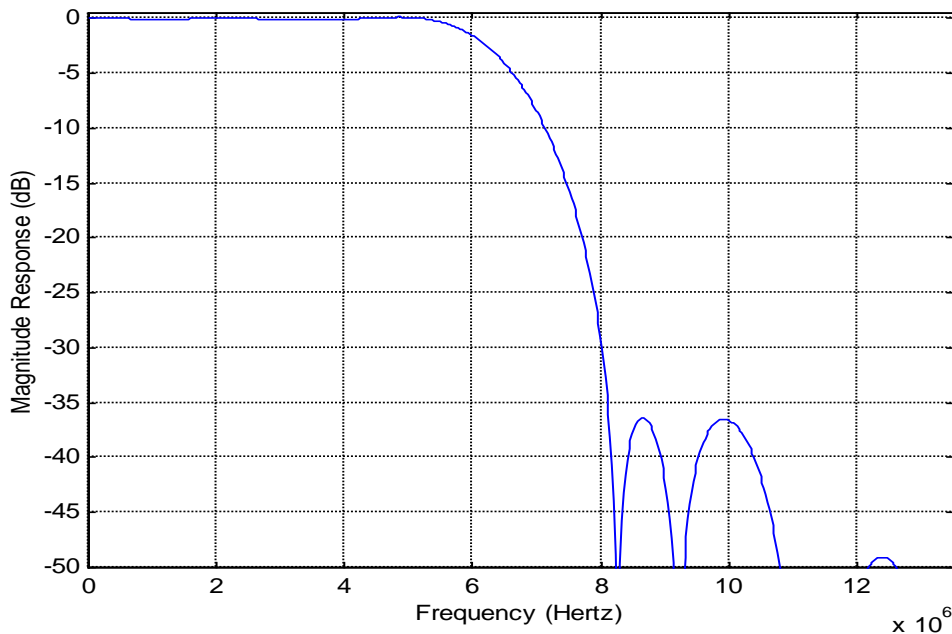

FIGURE 5. THE CHARACTERISTIC OF DECIMATION FILTER

### AGC AND CLAMPING

All four analog channels have built-in clamping circuit that restores the signal DC level. The Y channel restores the back porch of the digitized video to a level of 60. This operation is automatic through internal

feedback loop. The Automatic Gain Control (AGC) of the Y channel adjusts input gain so that the sync tip is at a desired level. Programmable white peak protection logic is included to prevent saturation in the case of abnormal signal proportion between sync and white peak level.

## **SYNC PROCESSING**

The sync processor of TW2851 detects horizontal synchronization and vertical synchronization signals in the composite video signal. The processor contains a digital phase-locked-loop and decision logic to achieve reliable sync detection in stable signal as well as in unstable signals such as those from VCR fast forward or backward.

The vertical sync separator detects the vertical synchronization pattern in the input video signals. In addition, the actual sync determination is controlled by a detection window to provide more reliable synchronization. An option is available to provide faster responses for certain applications. The field status is determined at vertical synchronization time. The field logic can also be controlled to toggle automatically while tracking the input.

## **Y/C SEPARATION**

The color-decoding block contains the luminance/chrominance separation for the composite video signal and multi-standard color demodulation. For NTSC and PAL standard signals, the luminance/chrominance separation can be done either by comb filter or notch/band-pass filter combination. For SECAM standard signals, adaptive notch/band-pass filter is used. The default selection for NTSC/PAL is comb filter.

In the case of comb filter, the TW2851 separates luminance (Y) and chrominance (C) of a NTSC/PAL composite video signal using a proprietary 4H adaptive comb filter. The filter uses a four-line buffer. Adaptive logic combines the upper-comb and the lower-comb results based on the signal changes among the previous, current and next lines. This technique leads to excellent Y/C separation with small cross luminance and cross color at both horizontal and vertical edges

Due to the line buffer used in the comb filter, there are always two lines processing delay at the output except for the component input mode which has only one line delay. If notch/band-pass filter is selected, the characteristics of the filters of luminance notch filter is shown in 0 for both NTSC and PAL system.

## **COLOR DECODING**

### **Chrominance Demodulation**

The color demodulation for NTSC and PAL standard is done by first quadrature mixing the chrominance signal to the base band. A low-pass filter is then used to remove carrier signal and yield chrominance components. The low-pass filter characteristic can be selected for optimized transient color performance. For the PAL system, the PAL ID or the burst phase switching is identified to aid the PAL color demodulation.

For SECAM, the color information is FM modulated onto different carrier. The demodulation process therefore consists of FM demodulator and de-emphasis filter. During the FM demodulation, the chrominance carrier frequency is identified and used to control the SECAM color demodulation.

The sub-carrier signal for use in the color demodulator is generated by direct digital synthesis PLL that locks onto the input sub-carrier reference (color burst). This arrangement allows any sub-standard of NTSC and PAL to be demodulated easily with single crystal frequency.

0 and 0 show the frequency response of Chrominance Band-Pass and Low-Pass Filter Curves.

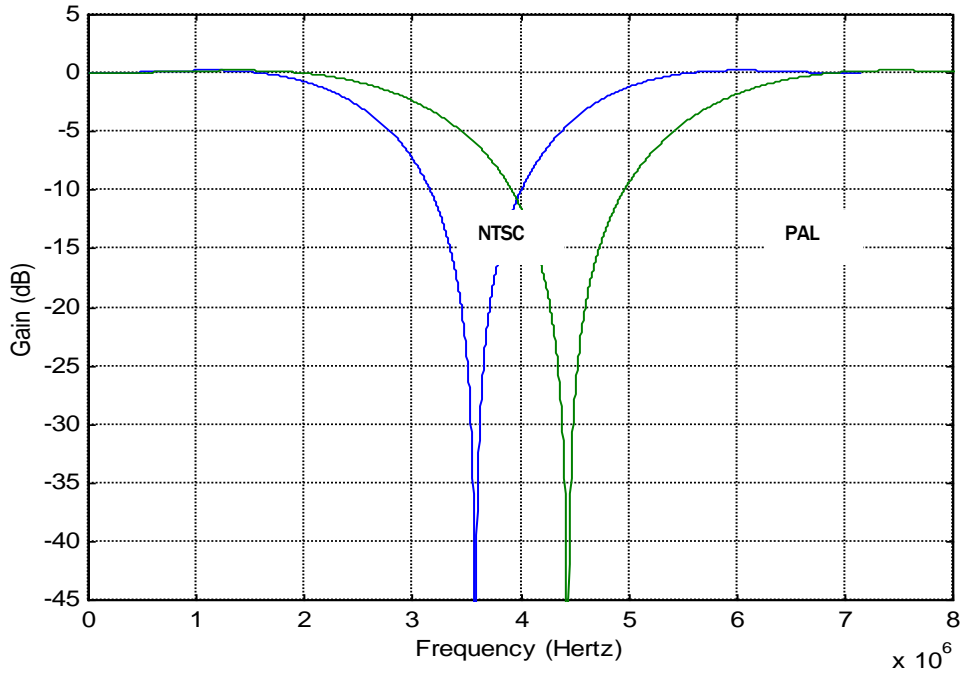

FIGURE 6. THE CHARACTERISTICS OF LUMINANCE NOTCH FILTER FOR NTSC AND PAL

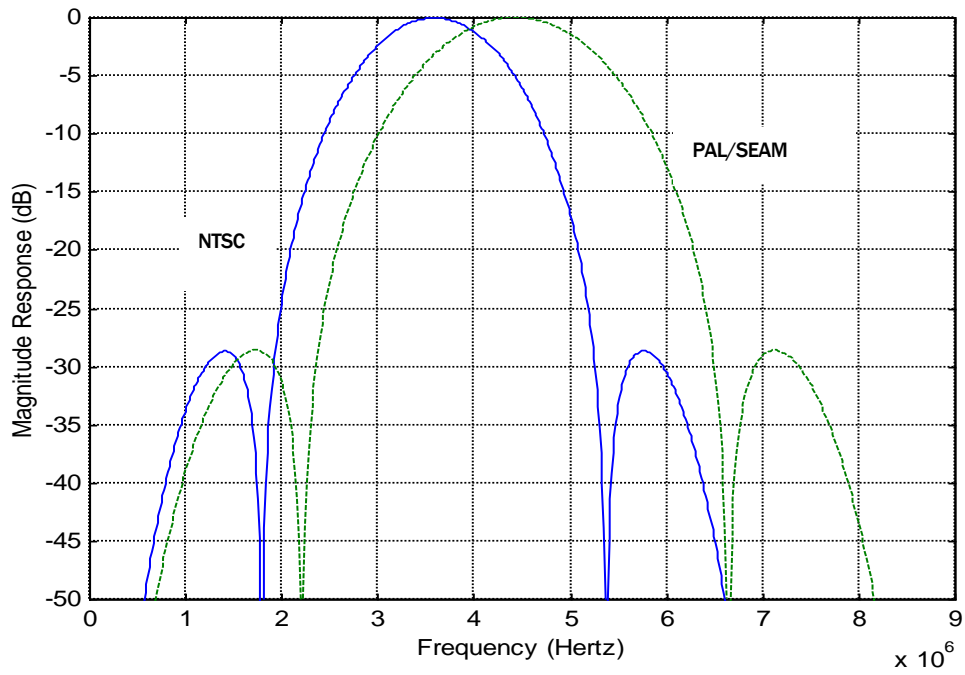

FIGURE 7. THE CHARACTERISTICS OF CHROMINANCE BAND-PASS FILTER FOR NTSC AND PAL

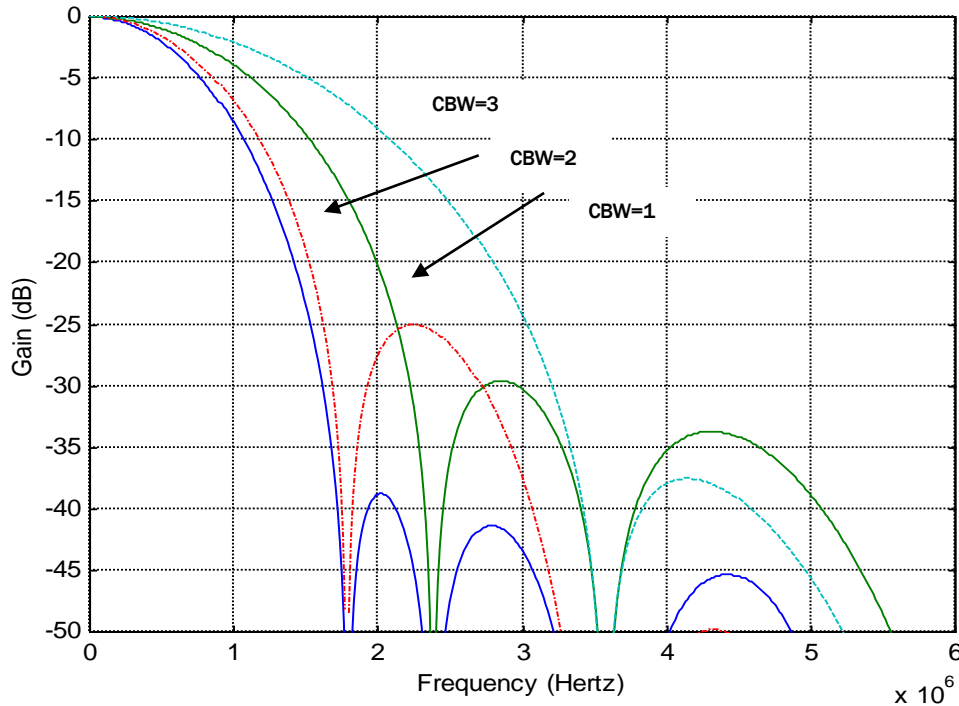

FIGURE 8. THE CHARACTERISTICS OF CHROMINANCE LOW-PASS FILTER CURVES

### ACC (Automatic Color gain control)

The Automatic Chrominance Gain Control (ACC) compensates the reduced amplitudes caused by high-frequency loss in video signal. In the NTSC/PAL standard, the color reference signal is the burst on the back porch. It is measured to control the chrominance output gain. The range of ACC control is -6db to +24db.

## CHROMINANCE PROCESSING

### Chrominance Gain, Offset and Hue Adjustment

When decoding NTSC signals, TW2851 can adjust the hue of the chrominance signal. The hue is defined as a phase shift of the subcarrier with respect to the burst. This phase shift of NTSC decoding can be programmed through a control register. For the PAL standard, the PAL delay line is provided to compensate any hue error; therefore, there is no hue adjustment available. The color saturation can be adjusted by changing the gain of Cb and Cr signals for all NTSC, PAL and SECAM formats. The Cb and Cr gain can be adjusted independently for flexibility.

### CTI (Color Transient Improvement)

The TW2851 provides the Color Transient Improvement function to further enhance the image quality. The CTI enhance the color edge transient without any overshoot or under-shoot.

## LUMINANCE PROCESSING

The TW2851 adjusts brightness by adding a programmable value (in register BRIGHTNESS) to the Y signal. It adjusts the picture contrast by changing the gain (in register CONTRAST) of the Y signal.

The TW2851 also provide programmable peaking function to further enhance the video sharpness. The peaking control has built-in coring function to prevent enhancement of noise.

The 0 shows the characteristics of the peaking filter for four different gain modes and different center frequencies.

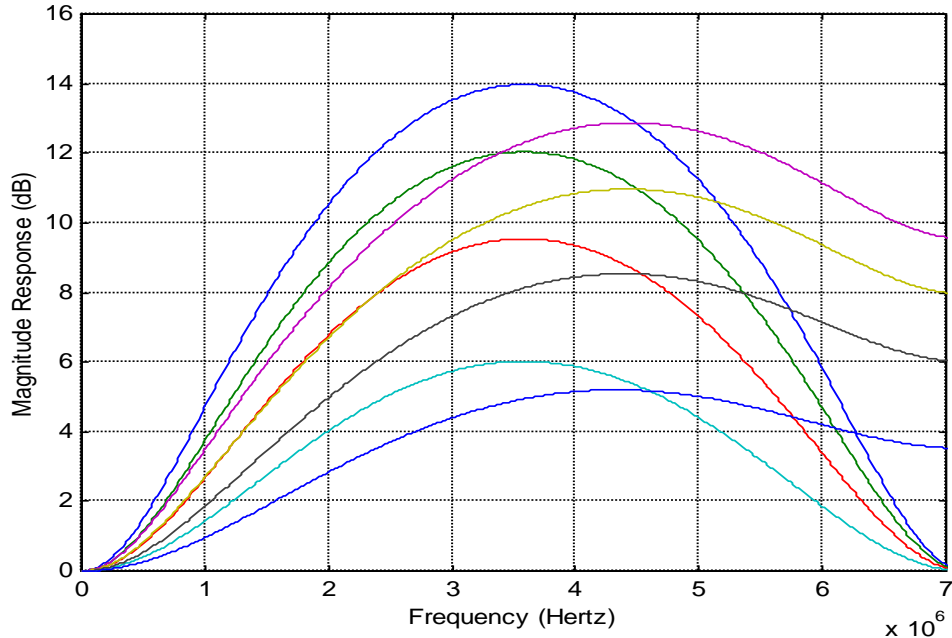

FIGURE 9. THE CHARACTERISTIC OF LUMINANCE PEAKING FILTER

## PSEUDO 8 CHANNELS

The TW2851 has 2 CVBS analog inputs for each video decoder. With the control from MCU, it is possible to support non-real-time 8-channel videos by toggling the analog switch back and forth using register ANA\_SW1 ~ ANA\_SW4 (0x057). The MCU switches the analog multiplexer, and wait for a period of time until the picture from video decoder is stable, then issues a strobe signal to capture a field/frame to one of the display / record / SPOT video buffer. Once the field/frame is captured, the strobe signal is self-cleared, and the MCU can switch the analog mux again to change to the other analog input signal. The result of this analog mux toggling is being able to support two analog inputs with a single video decoder and appearing as having 8 video decoders. This practically increases the analog channel number of TW2851 from 4 to 8, except each channel is non-real-time. In order to support the pseudo 8 channels, the display/record/SPOT path needs to be set to the strobe mode to capture the field/frame properly. See the description for each of these paths for details.

## CROPPING FUNCTION

The cropping function crops a video image into a smaller size. The active video region is determined by the HDELAY, HACTIVE, VDELAY and VACTIVE registers (0x002 ~ 0x006, 0x012 ~ 0x016, 0x022 ~ 0x026, 0x032 ~ 0x036). The first active line is defined by the VDELAY register and the first active pixel is defined by the HDELAY register. The VACTIVE register can be programmed to define the number of active lines in a video field, and the HACTIVE register can be programmed to define the number of active pixels in a video line. The horizontal delay register HDELAY are set to crop out unwanted pixels from horizontal blank interval. The horizontal active register HACTIVE determines the number of active pixels in a cropped line. The HACTIVE is typically set to 720 for both NTSC and PAL system for full screen. Note that these values are referenced to the pixel number before scaling. Therefore, even if the scaling ratio is changed, the active video region used for scaling remains unchanged as set by the HDEALY and HACTIVE register. In order for the cropping to work properly, the following equation should be satisfied.

$$\text{HDELAY} + \text{HACTIVE} < \text{Total number of pixels per line}$$

Where the total number of pixels per line is 858 for NTSC and 864 for PAL

The vertical delay register VDELAY determines the number of lines cropped at the upper side of the image. The vertical active register (VACTIVE) determines the number of active lines in the cropped. These values are

referenced to the incoming scan lines before the vertical scaling. In order for the vertical cropping to work properly, the following equation should be satisfied.

$$VDELAY + VACTIVE < \text{Total number of lines per field}$$

Where the total number of lines per field is 262 for NTSC and 312 for PAL

To process full size region, the VDELAY should be set to 0 and VACTIVE set to 240 for NTSC and the VDELAY should be also set to 0 and VACTIVE set to 288 for PAL.

## NOISE REDUCTION

Behind the 4 video decoders are four sets of automatic noise reduction filters. The focus of the noise filter is on Gaussian white noise and spot noise which is commonly generated by signal pick-up in the camera or in analog channels, especially under poor lighting conditions. The Gaussian white noise is usually low amplitude (low noise energy) and can be reduced by linear filter.

The automatic noise filter consists of a noise estimation module and a noise filtering module. Before the noise filtering, a noise estimation process is performed to detect whether the incoming video signal is corrupted and how strong the noise is. The noise estimated includes short-term and long-term noise level. The estimated result is passed to the noise reduction filter to turn on/off the noise filter and/or set the strength of filtering. Using the noise estimation module, the automatic noise reduction can intelligently detect the noise, the edge, and the motion of the video picture. It turns on the noise filtering only when the noise is detected. The noise filtering will turn off automatically at the edge of objects or while the object is moving, in order to preserve the highest sharpness as possible. The automatic adjustment can also be turned off by setting a force mode control register. The noise filter is based on a variant of sigma nearest neighbor selection filter using IIR implementation. This noise filter can work on the range between 40 dB to 30 dB in 2 steps of 5 dB.

The output of the noise reduction is fed through three downscalers and eventually used for displaying in display / record / SPOT path. The TW2851 allows the noise reduction be independently turned on/off for each the display / record / SPOT path using registers 0x305 and 0x306.

## DOWNSCALERS

The TW2851 has total of twelve downscalers in the analog video input path, with three downscalers associated with each of the video decoder / noise reduction output. The three downscalers are used for display, record, and SPOT respectively. The three downscalers can be configured independently using different scaling factor. The way of configuring the scaling factor is through specifying the source video size (scaler input size), and the target video size (scaler output size). The source sizes are specified in register 0x387 ~ 0x38B, 0x397 ~ 0x39B, 0x3A7 ~ 0x3AB, and 0x3B7 ~ 0x3BB. The target size are specified in register 0x380 ~ 0x385, 0x390 ~ 0x395, 0x3A0 ~ 0x3A5, and 0x3B0 ~ 0x3B5.

Note that the display downscalers are free scaler. That is, the video size can be downscaled to various size freely. While the record / SPOT downscalers are fix downscaler. They can only be downscaled to scaling factor of 1, 1/2, 1/4 in either horizontal or vertical direction. Scaling factors between 1 and 1/2 are not allowed.

## MOTION DETECTION

The TW2851 supports a motion detector for each of the 4 video decoders. The built-in motion detection algorithm uses the difference of luminance level between current and the reference field.

To detect motion properly according to situation needed, the TW2851 provides several sensitivity and velocity control parameters for each motion detector. The TW2851 supports manual strobe function to update motion detection so that it is more appropriate for user-defined motion sensitivity control.

When motion is detected in any video inputs, the TW2851 provides the interrupt request to host via the IRQ pin. Through which the host processor can read the motion information by accessing the motion status from register 0x6F1 ~ 0x6F4, and 0x690 ~ 0x6EF.



### Mask and Detection Region Selection

The motion detection algorithm utilizes the full screen video data and detects individual motion of 16x12 cells. This full screen for motion detection consists of 704 pixels and 240 lines for NTSC and 288 lines for PAL. Starting pixel in horizontal direction can be shifted from 0 to 15 pixels using the MD\_PIXEL\_OS (0x61B) register.

Each cell can be masked via the MD\_MASK (0x690 ~ 0x6EF) registers as illustrated in 0. If the mask bit in specific cell is set, the related cell is ignored for motion detection. The MD\_MASK register has different function for reading and writing mode. For writing mode, setting MD\_MASK register to "1" inhibits the specific cell from detecting motion. For reading mode, the MD\_MASK register provides three different kinds of information depending on the MDn\_MASK\_SEL (0x616) register. With MDn\_MASK\_SEL = "0", the state of MD\_MASK register read back the result of VIN\_A motion detection, with "1" denoting motion detected and "0" no motion detected in the cell. With MDn\_MASK\_SEL = "1", the MD\_MASK register shows the results of VIN\_B motion detection. With MDn\_MASK\_SEL = "2", the state of MD\_MASK register shows the masking information of cell of VIN\_A. And with MDn\_MASK\_SEL = "3", it shows the masking information of cell of VIN\_B.

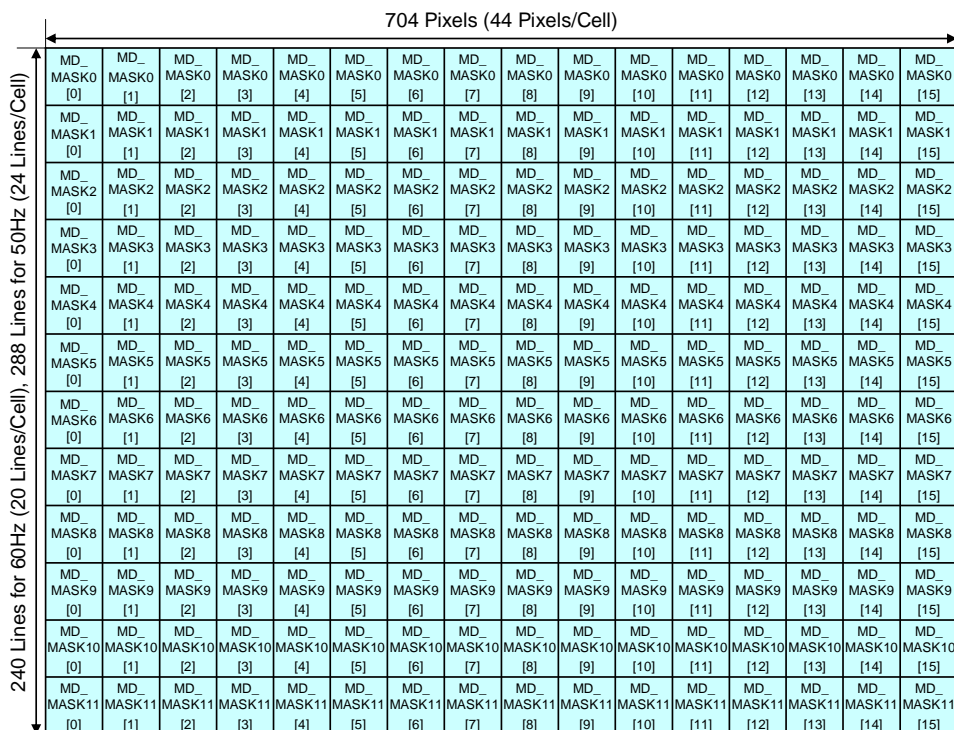

FIGURE 10. MOTION MASK AND DETECTION CELL

**Sensitivity Control**

The motion detector has 4 sensitivity parameters to control threshold of motion detection such as the level sensitivity via the MD\_LVSENS (0x61C) register, the spatial sensitivity via the MD\_SPSSENS (0x61E) and MD\_CELSENS (0x61D) register, and the temporal sensitivity parameter via the MD\_TMPSENS (0x61B) register.

**Level Sensitivity**

In built-in motion detection algorithm, the motion is detected when luminance level difference between current and reference field is greater than MD\_LVSENS value. Motion detector is more sensitive for the smaller MD\_LVSENS value and less sensitive for the larger. When the MD\_LVSENS is too small, the motion detector may be weak in noise.

**Spatial Sensitivity**

The TW2851 uses 192 (16x12) detection cells in full screen for motion detection. Each detection cell is composed of 44 pixels and 20 lines for NTSC and 24 lines for PAL. Motion detection using only luminance level difference between two fields is very weak for pictures with spatial random noise. To remove the fake motion detected from the random noise, the TW2851 supports a spatial filter via the MD\_SPSSENS register which defines the number of detected cell to decide motion detection in full size image. The large MD\_SPSSENS value increases the immunity of spatial random noise.

Each detection cell has 4 sub-cells. The actual motion detection result of each cell comes from comparison of 4 sub-cells in it. The MD\_CELSENS defines the number of detected sub-cell to decide motion detection in cell. That is, the large MD\_CELSENS value increases the immunity of spatial random noise in detection cell.

## Temporal Sensitivity

Similarly, temporal filter is used to remove the fake motion detection from the temporal random noise. The MD\_TMPSENS regulates the number of taps in the temporal filter to control the temporal sensitivity so that the large MD\_TMPSENS value increases the immunity of temporal random noise.

## Velocity Control

A motion has various velocities. That is, in a fast motion an object appears and disappears rapidly between the adjacent fields while in a slow motion it is to the contrary. As the built-in motion detection algorithm uses only the luminance level difference between two adjacent fields, a slow motion is harder to detect than a fast motion. To compensate this weakness, the current field is compared with a previous field up to 64-field time interval before. The MD\_SPEED (0x61D) parameter adjusts the field interval in which the luminance level is compared. Thus, for detection of a fast motion a small value is needed and for a slow motion a large value is required. The parameter MD\_SPEED value should be greater than MD\_TMPSENS value.

Additionally, the TW2851 has 2 more parameters to control the selection of reference field. The MD\_FIELD (0x61C) register is a field selection parameter such as odd, even, any field or frame.

The MD\_REFFLD (0x61C) register is used to control the updating period of reference field. For MD\_REFFLD = "0", the interval from current field to reference field is always same as the MD\_SPEED. It means that the reference field is always updated every field. The 0 shows the relationship between current and reference field for motion detection when the MD\_REFFLD is "0".

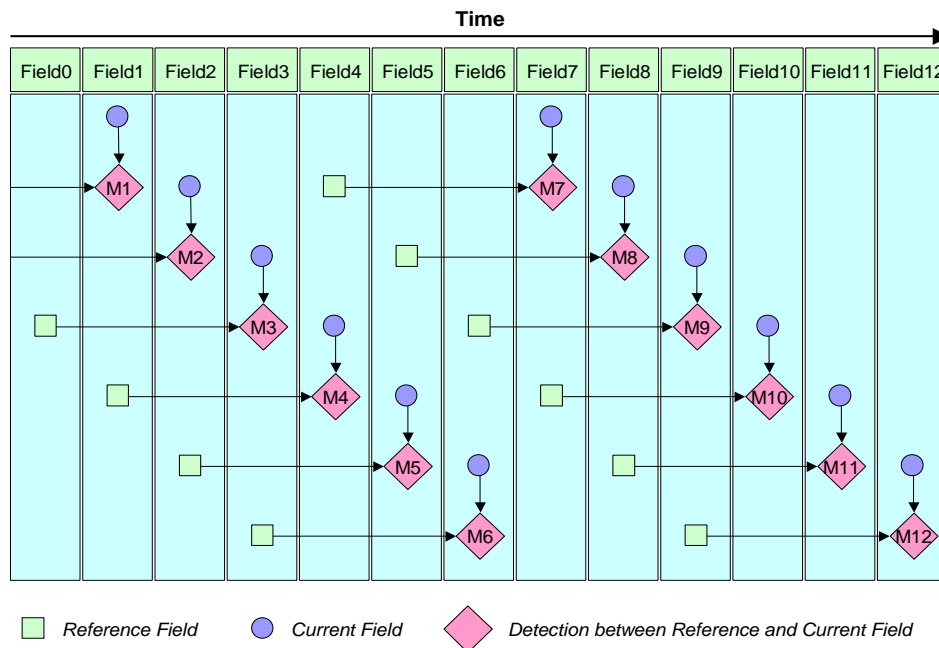

FIGURE 11. THE RELATIONSHIP BETWEEN CURRENT AND REFERENCE FIELD WHEN MD\_REFFLD = "0"

The TW2851 can update the reference field only at the period of MD\_SPEED when the MD\_REFFLD is high. For this case, the TW2851 can detect a motion with sense of a various velocity. The 0 shows the relationship between current and reference field for motion detection when the MD\_REFFLD = "1".

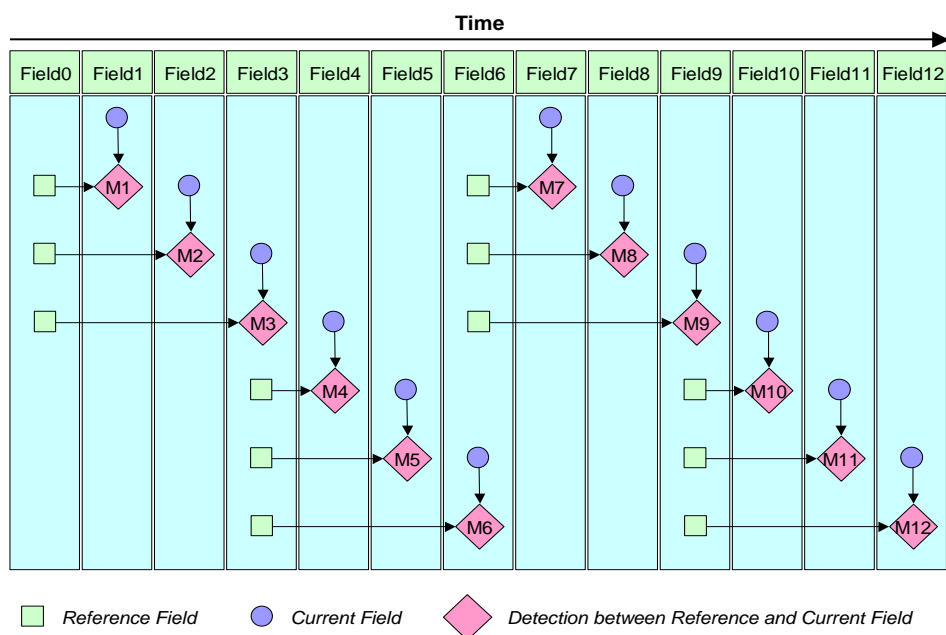

FIGURE 12. THE RELATIONSHIP BETWEEN CURRENT AND REFERENCE FIELD WHEN MD\_REFFLD = "1"

The TW2851 also supports the manual detection timing control of the reference field/frame via the MD\_STRB\_EN and MD\_STRB (0x61A) register. For MD\_STRB\_EN = "0", the reference field/frame is automatically updated and reserved on every reference field/frame. For MD\_STRB\_EN = "1", the reference field/frame is updated and reserved only when MD\_STRB = "1". In this mode, the interval between current and reference field/frame depends on user's strobe timing. This mode is very useful for a specific purpose like non-periodical velocity control and very slow motion detection.

The TW2851 also provides dual detection mode for non-real-time application such as pseudo-8ch application via MD\_DUAL\_EN (0x61A) register. For MD\_DUAL\_EN = 1, the TW2851 can detect dual motion independently for VIN\_A and B Input which is defined by the ANA\_SWn (n=0~3) at 0x057 register. In this case, the MD\_SPEED is limited to 31.

## BLIND DETECTION

The TW2851 supports a blind detection for each of the 4 analog video inputs and generated an interrupt to the host when a blind condition is detected. A blind condition is detected when a camera is shaded / blocked by some unknown object and the video level in wide area of a field is almost equal to average video level of the field.

The TW2851 has two sensitivity parameters to detect blind input such as the level sensitivity via the BD\_LVSENS (0x61E) register and spatial sensitivity via the BD\_CELSENS (0x61A) register.

The TW2851 uses total 768 (30x224) cells in full screen for blind detection. The BD\_LVSENS parameter controls the threshold of level between cell and field average. The BD\_CELSENS parameter defines the number of cells to detect blind. For BD\_CELSENS = "0", the number of cell whose level is same as average of field should be over than 60% to detect blind, 70% for BD\_CELSENS = "1", 80% for BD\_CELSENS = "2", and 90% for BD\_CELSENS = "3". That is, the large value of BD\_LVSENS and BD\_CELSENS makes blind detector less sensitive.

The TW2851 also supports dual detection mode for non-real-time application such as pseudo-8ch application via the MD\_DUAL\_EN (0x61A) register. The host can read blind detection information for both VIN\_A and VIN\_B input via MCU interrupt. When blind input is detected in any video inputs, the host processor can read the information by accessing the INTERRUPT\_VECT2 (0x1D2) register. This status information is updated in the vertical blank period of each input.

## NIGHT DETECTION

The TW2851 supports night detection for each of the 4 analog video inputs and generates an interrupt to the host when a night condition is detected. If an average of a field video level is very low, this input is interpreted as night. Otherwise, the input is treated as day.

The TW2851 has two sensitivity parameters to detect night input such as the level sensitivity via the ND\_LVSENS (0x61F) register and the temporal sensitivity via the ND\_TMPSSENS (0x61F) register. The ND\_LVSENS parameter controls threshold level of day and night. The ND\_TMPSSENS parameter regulates the number of taps in the temporal low pass filter to control the temporal sensitivity. The large value of ND\_LVSENS and ND\_TMPSSENS makes night detector less sensitive.

The TW2851 also supports dual detection mode for non-real-time application such as pseudo-8ch application via the MD\_DUAL\_EN (0x61A) register. The host can read night detection information for both VIN\_A and VIN\_B input via the MCU interrupt. When night input is detected in any video inputs, the TW2851 provides the interrupt request to host via the IRQ pin. The host processor can read the information of night detection by accessing the INTERRUPT\_VECT1 (0x1D1) register. This status information is updated in the vertical blank period of each input.

## Digital Video Input

The TW2851 supports digital video input in 8-bit ITU-R BT.656, 16-bit BT.601, and 16-bit BT.1120 standards. It has built-in ITU-R BT 656/601/1120 decoders. The digital video input can be used to display single-channel video from any source, or to display a multi-channel video stream generated from a decompression engine. In the multi-channel stream case, there will be channel ID information embedded in the video stream to allow the downstream modules to de-multiplex the video stream. When using the digital video input in BT.1120 format, TW2851 only supports single channel video.

### ITU-R BT. 656 DIGITAL VIDEO INPUT FORMAT

When receiving video input in the BT. 656 format, TW2851 is capable of running at up to 4X clock rate of 108 MHz. With this a multi-channel field interleaved video stream of 8 half D1 field rate can be received through a single 8-bit digital interface. TW2851 is able to de-multiplex the single video stream, extracts 4 channels, and perform cropping/scaling function on each channel independently. The timing of BT. 656 digital video input is illustrated in Figure 13.

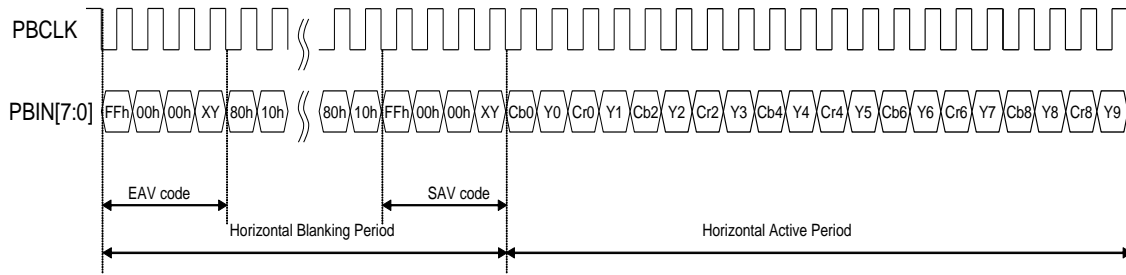

FIGURE 13. TIMING DIAGRAM OF ITU-R BT. 656 FORMAT

TW2851 has a built-in BT. 656 decoder with error correction for decoding SAV/EAV information. The SAV and EAV sequences are shown in Table 2.

TABLE 2. ITU-R BT.656 SAV AND EAV CODE SEQUENCE

CONDITION			656 FVH VALUE			SAV/EAV CODE SEQUENCE												
FIELD	VERTICAL	HORIZONTAL	F	V	H	FIRST	SECOND	THIRD	FOURTH									
EVEN	Blank	EAV	1	1	1	0xFF	0x00	0x00	0xF1									
		SAV			0				0xEC									
EVEN	Active	EAV	1	0	1				0xFF	0x00	0x00	0xDA						
		SAV			0							0xC7						
ODD	Blank	EAV	0	1	1							0xFF	0x00	0x00	0xB6			
		SAV			0										0xAB			
ODD	Active	EAV	0	0	1										0xFF	0x00	0x00	0x9D
		SAV			0													0x80

## ITU-R BT. 601 DIGITAL VIDEO INPUT FORMAT

The digital video input can also take 16-bit ITU-R BT.601 standard. Additional signals such as HSYNC and VSYNC are used for video timing control. The BT. 601 interface is able to run up to 4X clock rate (54 MHz) as well. With this a multi-channel field/frame interleaved video stream of 4 D1 frame rate can be received through a single 16-bit digital interface. Again, the TW2851 is able to de-multiplex this single video stream into 4 channels, and perform cropping/scaling function on each channel independently.

The timing of BT. 601 digital video input is illustrated in

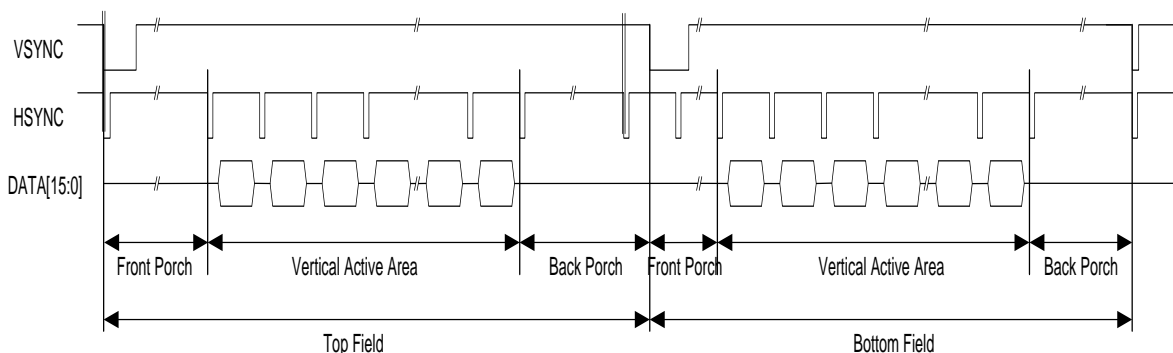

FIGURE 14. THE VSYNC/HSYNC TIMING IN BT. 601 INTERFACE

Note that there is no field ID input. The field information is derived from the leading edge of the VSYNC signal. If this leading edge falls into a window (say,  $\pm N$  clock cycles) around the leading edge of HSYNC signal, then the following field is top field. If it does not fall into such window, then the following field is bottom field. The leading edge of the the VSYNC signal is the timing the field signal toggles.

## ITU-R BT. 1120 DIGITAL VIDEO INPUT FORMAT

The digital video input can also take video streams in 16-bit ITU-R BT.1120 format. The BT. 1120 format supports 1920x1125 (60 Hz) or 1920x1250 (50 Hz) resolution with a clock rate up to 74.25 MHz. The BT.1120 input channel is a single channel video interface. There is no multi-channel interleaving or channel ID support. Similar to the BT. 656 stream, the timing control signals are embedded in the data stream through EAV/SAV header, defined the same way as BT. 656 in Table 2.

## MULTI-CHANNEL VIDEO FORMAT

The video stream generated by TW2851 carries multi-channel video stream, which consists of multiple video channels interleaved in one video stream. The multiple channels can be time interleaved in unit of a field (or a frame when running at 27 MHz), or space multiplexed (in unit of CIF picture). The time/space multiplexed format can vary flexibly from field/frame to field/frame. The "Picture Type" specifies how the multiple channels are put together in each field/frame. There are total of 8 possible ways, as listed in the following figure. Note that there are 4 channels at most in each field. The auto-channel ID in the VBI carries up to 4 channel IDs as well. The first channel ID will be CH\_0. The second, third and fourth being CH\_1, CH\_2, and CH\_3 correspondingly. Figure 15 shows how the 4 channel IDs are mapped into each field. Note that the "Picture Type" automatically defines the picture size of each channel. The Auto-Channel ID in the VBI specifies the location of each channel. When there are 4 channels, the size of each channel is evenly divided from the full size of the picture. These various picture types are provided to allow external CODEC to make use the stream as easy as possible. The CODEC can pick whatever is most fit into the design of their chip. Out of the many types planned, the current TW2851 revB2 only supports field interleaving (type 0/2/) at 108/54/27 MHz, and frame interleaving (type 1 / 3) at 27 MHz.



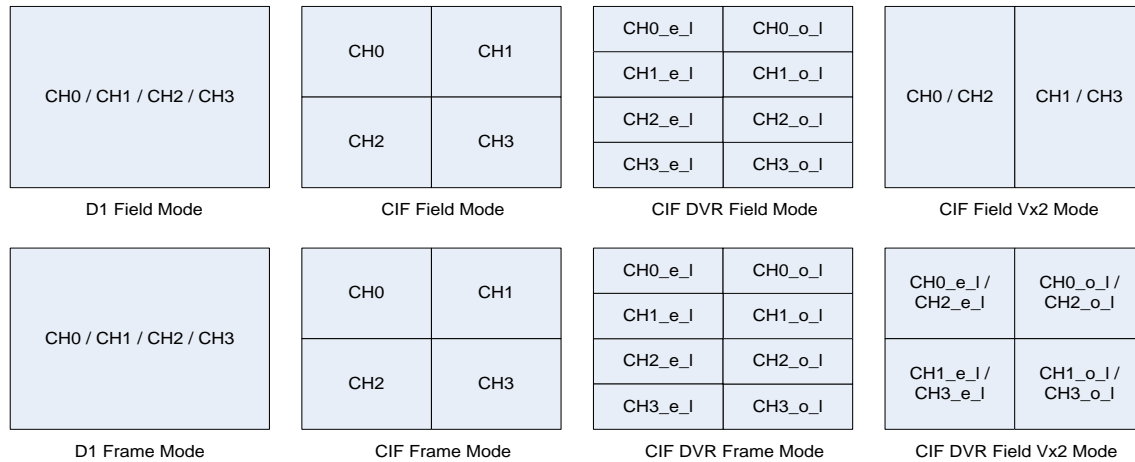

FIGURE 15. MULTI-CHANNEL PICTURE TYPES SUPPORTED BY TW2851

### D1 Field Mode (“Picture Type” = 0)

When the “Picture Type” specified in the channel ID is 0, the field succeeds the channel ID consists of 1 single channel. A “Field Mode” means the source channel uses only a field out of a frame for recording/display. How this single field is used at the display or compression CODEC depends on their implementation.

### D1 Frame Mode (“Picture Type” = 1)

When the “Picture Type” specified in the channel ID is 1, the 2 field (1 frame) succeeds the channel ID consists of 1 single channel. A “Frame Mode” means both Odd/Even fields of the original channel are used for recording/display. At the display, the Odd field is used as the Odd field output, and the Even field is used as the Even field output. No interpolation is needed in this case.

### CIF Field Mode (“Picture Type” = 2)

When the “Picture Type” specified in the channel ID is 2, it represents a Field Mode (as defined previously in D1 Field mode) with video of CIF size. Since each video is CIF, up to 4 channels can be allocated into a single D1 field. Note that in Field Mode, Even and Odd fields carry different channels. So total of 8 channels can be allocated.

### CIF Frame Mode (“Picture Type” = 3)

When the “Picture Type” specified in the channel ID is 3, it represents a Frame Mode (as defined previously in D1 Frame Mode) with video of CIF size. This time, up to 4 channels can be allocated into a single D1 frame.

### CIF DVR Field Mode (“Picture Type” = 4)

When the “Picture Type” specified in the channel ID is 4, it represents a CIF DVR Field Mode. The CIF DVR Field mode is very similar to the CIF Field Mode, except that the arrangement of pixel data of each CIF video on a D1 field is different. The CIF Field Mode arranges 4 channels at 4 corners. The CIF DVR Field Mode arranges 4 channels from top to bottom on a D1 field. The pixel data of each channel are arranged that the odd lines are at the left and the even lines are at the right. With this, the DVR mode generates continuous video stream for each channel such that the external CODEC only need to handle one channel at a time. See Figure 15 for the example of the CIF DVR Field Mode format compared with CIF Field Mode.

### CIF DVR Frame Mode (“Picture Type” = 5)

When the “Picture Type” specified in the channel ID is 5, it represents the CIF DVR Frame Mode. Similar to CIF DVR Field Mode, the CIF DVR Frame Mode rearrange each CIF field/frame such that the Odd Lines are at the left, and the Even Lines are at the right. See Figure 15 for the example of the CIF Frame Mode format.

**CIF Vx2 Field Mode (“Picture Type” = 6)**

When the “Picture Type” specified in the channel ID is 6, it represents a CIF Vx2 Field Mode. The Vx2 mode means captures 2X of vertical lines of the field size to be display. With 2X of lines, the Odd lines are used for Odd field, and the Even lines are used for Even field. This mode is intended to capture a single field while used as a Frame at the output without interpolation. See Figure 15 for the CIF Vx2 Field Mode format.

**CIF Vx2 DVR Field Mode (“Picture Type” = 7)**

When the “Picture Type” specified in the channel ID is 7, it represents a CIF Vx2 DVR Field Mode. This mode is a combination of Vx2, DVR, and Field Mode. See Figure 15 for the CIF Vx2 Field Mode format.

**4D1 Frame Mode (“Picture Type” = 9)**

Picture Type 9 is very similar to Picture Type 3, except the frame size is 4 times bigger. The Picture Type 3 uses a D1 frame to carry 4 CIF channels, while the Picture Type 9 uses a BT 1120 frame to carry 4 D1 channels. To use this type, the input PB port is configured as BT. 1120 port, and the VACTIVE / HACTIVE size are configured to 4D1 rather than 1D1.

**PLAYBACK INPUT CHANNEL DE-MULTIPLEXER**

TW2851 supports up to four playback digital input ports (PB0 ~ PB3), each carries multiple channels within the video stream. The PB0 ~ PB3 can be in either of 8-bit, 16-bit or 24-bit playback interfaces in BT. 656, BT. 601, BT. 1120, or component RGB format. There are total of 32 PB data input pins which can be flexibly configured in various input configurations, as shown in Table 3.

TABLE 3. PLAYBACK INPUT CONFIGURATIONS

PB0_TYPE	PB1_TYPE	PB PORT 0	PB PORT 1	PB PORT 2	PB PORT 3
0	0	PB0_DIN[7:0] BT. 656	PB1_DIN[15:8] BT. 656	PB2_DIN[23:16] BT. 656	PB3_DIN[31:24] BT. 656
	1				
1	0	U / V = PB0_DIN[7:0] Y = PB1_DIN[7:0] BT. 601		PB2_DIN[23:16] BT. 656	PB3_DIN[31:24] BT. 656
	1		U / V = PB2_DIN[7:0] Y = PB3_DIN[7:0] BT. 601		
2	0	U / V = PB0_DIN[7:0] Y = PB1_DIN[7:0] BT. 1120		PB2_DIN[23:16] BT. 656	PB3_DIN[31:24] BT. 656
	1		U / V = PB2_DIN[7:0] Y = PB3_DIN[7:0] BT. 601		
3	X	R / V = PB2_DIN[7:0] G / Y = PB1_DIN[7:0] B / U = PB0_DIN[7:0]			PB3_DIN[31:24] BT. 656

The playback interface matches the desired channel number set in PB\_CHNUM (0x160, 0x170, 0x180, 0x190) with the channel IDs embedded within the video stream from each of the 4 ports, and generates up to 4 matched single-channel video streams (PB\_CH0 ~ PB\_CH3). Each of the PB\_CH0 ~ PB\_CH3 are single channel that can be cropped / scaled individually before writing into the DDR memory. The matching process generates the control signals PB\_PORT\_SEL0 ~ PB\_PORT\_SEL3 to select one of the 4 physical ports PB0 ~ PB3 for each of the PB\_CH0 ~ PB\_CH3 channel. The automatic matching result PB\_PORT\_SEL0 ~ PB\_PORT\_SEL3 can be read from register 0x101. Figure 16 shows how the input video streams from PB0 ~ PB3 are each checked against the PB\_CHNUM, and de-multiplexed into 4 single channels PB\_CH0 ~ PB\_CH3.

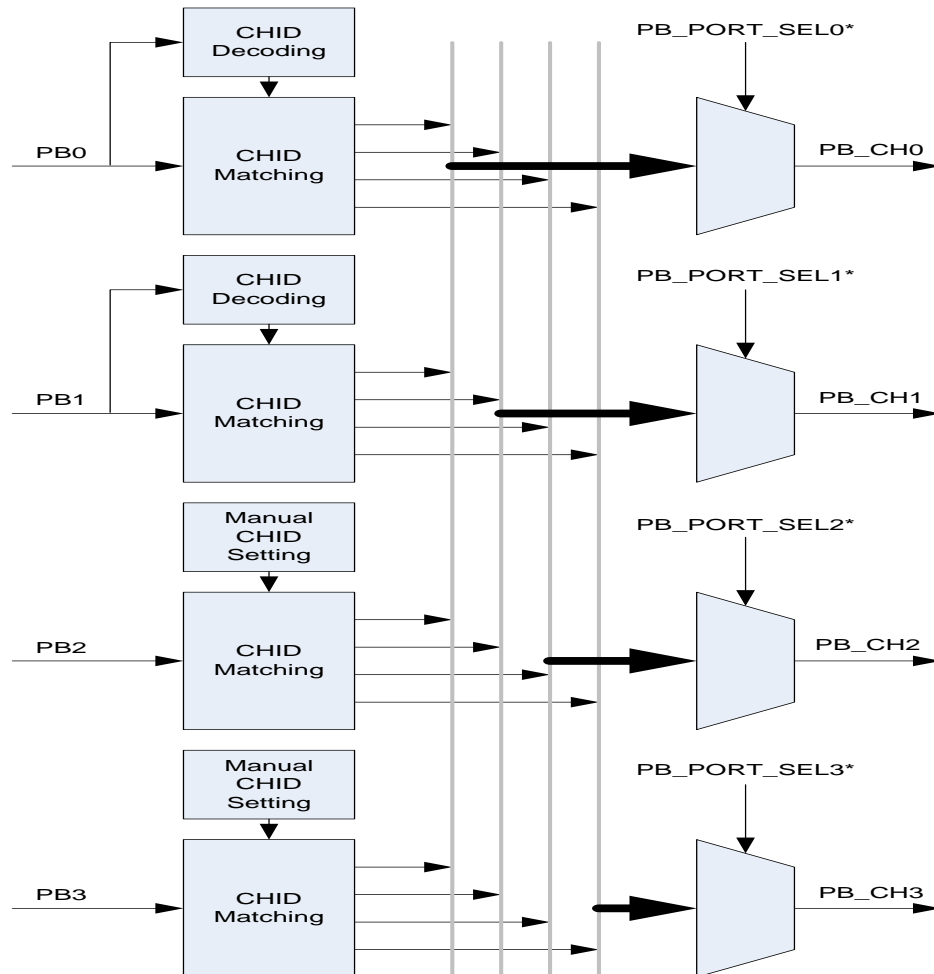

FIGURE 16. PLAYBACK INPUT DE-MULTIPLEXER

## CHANNEL ID DECODER

In a multi-channel video stream, the channel ID information associated with each field / frame is embedded in the video vertical blanking area right before the active field in order to identify the channels of pictures in that active field. A channel ID decoder extracts and provides this information, including “channel IDs”, “Picture Type”, to the crop / scale module to separate the multi-channel video stream into multiple single-channel video streams. In addition, an auto strobe signal is generated if the decoded channel ID matches the PB\_CHNUM in 0x160, 0x170, 0x180, and 0x190. This signal is sent along with the separated single-channel video streams to the write control module to capture the picture automatically into the external video buffer.

The first two digital input ports (PB0, PB1) are equipped with a channel ID decoder and channel ID matching module to match and de-multiplex the multiple video streams automatically. In addition, a manual channel ID setting can be used to replace the result from channel ID decoder. All 4 PB ports have the manual channel ID setting through the registers in 0x120 ~ 0x123, 0x130 ~ 0x133, 0x140 ~ 0x143, and 0x150 ~ 0x153. The manual channel ID setting is enabled by setting PBm\_MAN\_STRB\_EN (0x120 / 0x130 / 0x140 / 0x150) to “1”. The manual channel ID is useful if the incoming video stream does not carry any channel ID information in its VBI. Note, however, that when the manual channel IDs are used, it cannot vary from field to field. Those picture types with channel ID changing from field to field cannot be supported.

With 4 playback input ports, there are a maximum of 16 channels embedded in the incoming streams. The playback path is designed to extract 4 out of the 16 channels. There are 4 sets of channel ID registers PB\_CHNUM0 ~ PB\_CHNUM3 (0x160, 0x170, 0x180, 0x190) used for the matching module of each port. Each port will generate up to 4 channels. The PB\_CHNUM is a 5 bit ID, including the 2-bit chip ID (in cascade case), 2-bit port ID, and 1-bit of analog ID that needs to be matched with the PB\_ANAx (0x160, 0x170, 0x180, 0x190) to support Pseudo 8 channel application. If there are same Channel IDs extracted from more than 1 port, only the channel from the lowest playback port number is used. For details of Channel ID information embedded in VBI, please refer to the section on page 56.

## CROPPING AND SCALING FUNCTION

The TW2851 supports the cropping and scaling function at the output of channel de-multiplexer behind the digital input port. There are 4 cropping / scaling modules which use the decoded channel ID to automatically crop the multi-channel stream into multiple single-channel streams and match the input Picture Type / size automatically.

### Cropping

Similar to the cropping function in the analog CVBS path, the digital video input interface provides a cropping function to crop video into a smaller size as required by application. The active video region is determined by the HDELAY, HACTIVE, VDELAY and VACTIVE registers (0x124 ~ 0x129, 0x134 ~ 0x139, 0x144 ~ 0x149, 0x154 ~ 0x159). The first active line is defined by the VDELAY register and the first active pixel is defined by the HDELAY register. The VACTIVE register can be programmed to define the number of active lines in a video field, and the HACTIVE register can be programmed to define the number of active pixels in a video line.

The cropping feature is also used for input video streams with multiple channel of video on the same field (e.g. PIC\_TYPE 2 or 3) to separate out the intended channel from others. In this case, however, the HDELAY, VDELAY, HACTIVE, VACTIVE settings refer to the whole size of the field, instead of the size of each channel. The cropping function will automatically do additional cropping based on the PIC\_TYPE information to separate out the single channel.

## Scaling

The scaling function in digital input path is similar to the downscalers in the video decoder path. A setting of source and target video size are specified through register 0x162 ~ 0x165, 0x172 ~ 0x175, 0x182 ~ 0x185, and 0x192 ~ 0x195. The scalers used here are downscalers that can down scale freely to any size in multiple of 16-pixel steps. In case of CIF input that needs to be upscaled to D1, the TW2851 also provides a simple upscaler that can upscale the input at a fixed 2X scaling factor. This is set through PB\_H2X\_EN in registers 0x161, 0x171, 0x181, 0x191, and DP\_RD\_V\_2Xn (n= 0 ~ 3) in registers 0x250, 0x258, 0x260, and 0x268. The use of downscaler and upscaler can be turned on simultaneously to achieve scaling factor up to 2X the original size horizontally and vertically.

## Video Multiplexers

The TW2851 has three sets of video multiplexers, one for display, SPOT and record path each. All three multiplexers utilize a centralized external 256 Mbits DDR DRAM through a 16-bit data bus interface. The control of multiplexers are through the way the video are captured and read back to / from the external DDR SDRAM. The TW2851 supports 8-channel inputs for display path, 4-channel for SPOT path, and 4-channel for record path. The block diagram of video controller is shown in Figure 17.

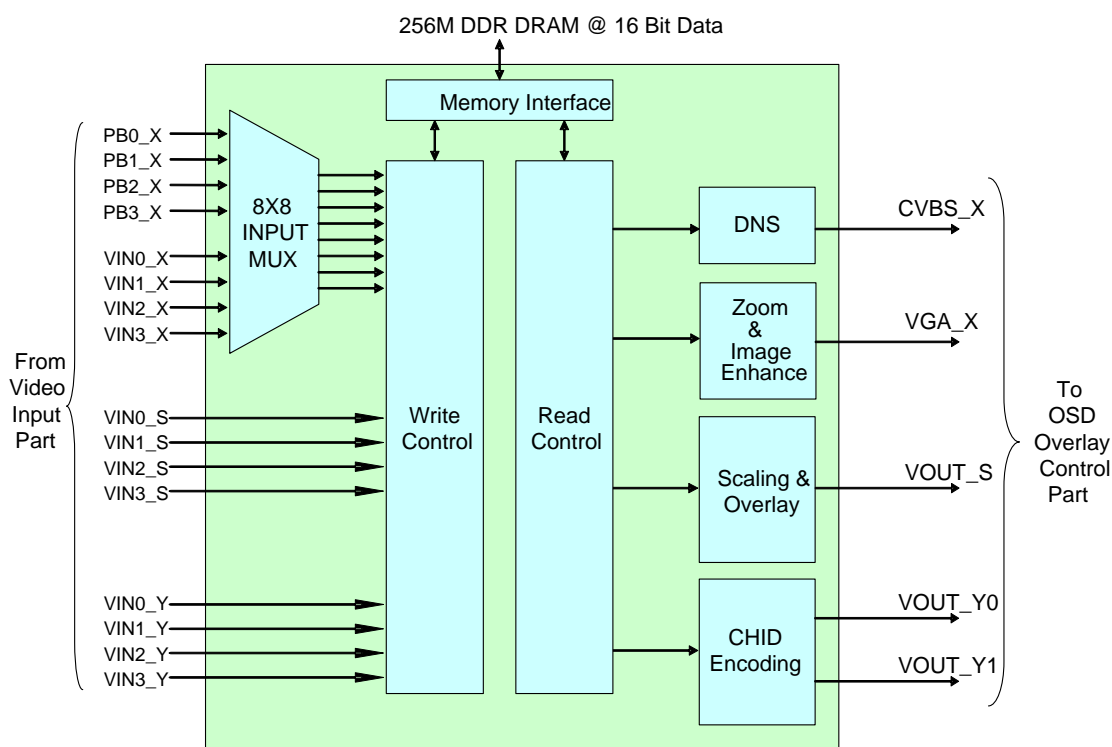

FIGURE 17. BLOCK DIAGRAM OF VIDEO CONTROLLER

## CAPTURE CONTROL

Each of the Display / Record / SPOT paths supports video capturing in two different ways: LIVE mode and STROBE mode. In LIVE mode, every incoming video is updated into the video buffer to show up at the output. In STROBE mode, the incoming video is updated only if a strobe signal is issued either internally on the chip or externally from the MCU.

There are two different strobe modes supported. One is the AUTO STROBE mode, one is the MANUAL STROBE mode. The video streams from the playback interface can run at the AUTO STROBE mode, where a strobe signal is generated on chip automatically through channel ID decoding and matching circuit. The video streams from the video decoder only runs at MANUAL STROBE mode. Each channel can be independently

operated in its own mode, either LIVE or STROBE mode. Table 4 shows the modes supported on each of the display / SPOT / record path.

TABLE 4. CAPTURE MODES SUPPORT OF DISPLAY/SPOT/RECORD PATHS

	LIVE MODE	STROBE MODE
DISPLAY / VD	YES	MANUAL
DISPLAY / PB	YES	AUTO
SPOT	YES	MANUAL
RECORD	YES	MANUAL

### Display Capture Modes

The display path capture mode is controlled by the DP\_FUNC\_MD (0x250 ~ 0x288).

#### **Live Mode (DP\_FUNC\_MD = 0)**

The LIVE mode captures every incoming field / frame into the video buffer into the external DDR memory. For inputs from video decoder, the input is always frame based. Every frame is updated and shown as a real-time video stream. For inputs from playback input, the capture mode is usually Auto Strobe Mode. However, playback LIVE mode can be forced on if PB\_FORCE\_LIVE (0x123, 0x133, 0x143, 0x153) is set to '1'. Under this mode, the incoming video stream always shows up independently of the PB\_CHNUM setting. The PB\_FORCE\_LIVE = 1 only take D1 frame mode. So the PBn\_MAN\_PIC\_TYPE has to be set to 0x01 in this type.

The LIVE mode capturing can be over-ruled with a freeze control by setting DP\_FREEZE<sub>m</sub> register (0x250/0x258/0x260/0x268/0x270/0x278/0x280/0x288) to 1. In this case, the incoming video will no longer be captured until this bit is cleared.

#### **Auto Strobe Mode (DP\_FUNC\_MD = 0)**

For playback digital inputs, a strobe can be provided automatically if there is a matching of PB\_CHNUM with the channel ID from VBI or from the manual mode setting. The TW2851 provides a channel ID matching mechanism to strobe only at the valid field / frame that matches the channel ID. The auto strobe mode capturing can also be over-ruled by a freeze control by setting DP\_FREEZE<sub>m</sub> register (0x250/0x258/0x260/0x268/0x270/0x278/0x280/0x288) to 1. In this case, the incoming video will no longer be captured even though there is a channel ID match, until this bit is cleared.

#### **Manual Strobe Mode (DP\_FUNC\_MD = 1)**

The strobe mode of display path is mainly used to support the pseudo 8 channel mode. When the video decoder is switching between VINA and VINB, the MCU is responsible for the timing of switching the multiplexer. After switching, the MCU wait for a certain amount of delay time until the video picture is stable, then issue the DP\_STRB\_REQ (0x24F) signal. The display path then captures a field/frame depending on the setting of DP\_STRB\_FLD (0x250 ~ 0x288). Once the capture is completed, the display module clears the DP\_STRB\_REQ signal. The MCU poll the DP\_STRB\_REQ signal, and perform the switching all over again.

### Record/SPOT Capture Modes

The record/SPOT path also supports either LIVE and STROBE mode individually for each port. The mode is controlled by RP\_FUNC\_MD<sub>n</sub> (0x210 ~ 0x213, 0x2A0 ~ 0x2A3). Each port can be configured to LIVE mode or STROBE mode individually using the FUNC\_MD.

#### **Live Mode (RP\_FUNC\_MD<sub>n</sub> = 0)**

In LIVE mode, the capture module captures every received field/frame into the video buffer into the external DDR memory. Depending on the RP\_PIC\_TYPE / SP\_PIC\_TYPE (0x215, 0x2A5), the captured field/frame is updated either per frame or per field. In addition to the existing picture type defined, the SPOT path also supports an additional picture type that allows all 16 channels QCIF to cascade onto one single output.

### **Strobe Mode (RP\_FUNC\_MD\_n = 1)**

The strobe mode captures a field / frame each time a strobe request is issued by the MCU. This allows the MCU to control the timing of capturing a field/frame, and is useful in supporting pseudo 8 channel. In pseudo 8 channel mode, the MCU switches the analog multiplexer from VINA to VINB, waits for a certain amount of time till the picture is stable, and issues a strobe signal to RP\_STROBE\_n / SP\_STROBE\_n (0x214, 0x2A4). Once a field/frame is captured, the strobe signal is cleared automatically. The MCU can poll this bit for capture completion, and starts the switching process all over again.

### **READ CONTROL**

The read control arranges the input channels at the output port in terms of both temporal control and spatial control. The spatial control specifies the location and the channel of each enabled window at the output. The temporal control specifies how the multiple channels are temporally interleaved to share the frame rate efficiently. Therefore each field / frame can carry video from different channels. For display path, every enabled window shows up all the time. No temporal control is involved. For record / SPOT path, the channels can be field / frame interleaved.

The control of temporal / spatial configurations is through either static register, or dynamic switch queue. The static control specifies the spatial / temporal control through a set of registers. The switch queue specifies the spatial / temporal control through a switch queue, with each entry of the queue determine the control in a field / frame.

### **Display Read Control**

For display path, the output channel does not change from field to field. So there is no temporal control. Spatially, the display path can show up to 8 video windows on the output monitor. In implementation, the window 0 has highest priority, and window 7 has lowest priority. Window 0 always stays on top, and covers other windows. Every video window is flexibly configurable in terms of size and location and is controlled by DP\_PICHLm (0x252, 0x25A, 0x262, 0x26A, 0x272, 0x27A, 0x282, 0x28A), DP\_PICHRm (0x253, 0x25B, 0x263, 0x26B, 0x273, 0x27B, 0x283, 0x28B), DP\_PICVTm (0x254, 0x25C, 0x264, 0x26C, 0x274, 0x27B, 0x284, 0x28B), and DP\_PICVBm (0x255, 0x25D, 0x265, 0x26D, 0x275, 0x27D, 0x285, 0x28D) for the left, right, top, bottom of each window.

The display path supports 8 input channels to fill into the 8 video windows. Channel 0 ~ 3 take inputs from either playback channel 0 ~ 3, or video decoder port 0 ~ 3 with analog selection 0 or 1. Channel 4 ~ 7 take inputs from video decoders 0 ~ 3 with analog selection 0 or 1. The Table 5 shows the input selections the display channel can support. Note that DP\_PBVD\_SEL is 4 bits. It controls each of channel 0 ~ 3 separately.

TABLE 5. DISPLAY CHANNEL CONFIGURATION

DISPLAY CHANNEL #	PLAYBACK WITH 4 VD CHANNELS DP_PBVD_SEL = 0	PSEUDO 8 CHANNELS DP_PBVD_SEL = 1
0	PB_CH0	VD_0 (A/B)
1	PB_CH1	VD_1 (A/B)
2	PB_CH2	VD_2 (A/B)
3	PB_CH3	VD_3 (A/B)
4	VD_0 (A/B)	VD_0 (A/B)
5	VD_1 (A/B)	VD_1 (A/B)
6	VD_2 (A/B)	VD_2 (A/B)
7	VD_3 (A/B)	VD_3 (A/B)

The display path display supports cascade function, allowing 4 chips of TW2851 to be connected together and merge all the windows into one single VGA / CVBS output. With 4-chip cascade, the display output can



support up to 32 windows in total. The priority of all video windows will be the downstream chips cover the upstream chips.

### **Record/SPOT Static Control (RP\_SM\_EN / SP\_SM\_EN = 0)**

To run the record / SPOT path at static mode, the RP\_SM\_EN / SP\_SM\_EN register (0x215, 0x2A5 for SPOT) is set to "0". Instead of arranging all windows flexibly as in the display path, the Record / SPOT path read control is less flexible. It uses the pre-specified configuration, described as picture types, shown in Figure 15, with each window either full screen or 1/4 of the whole screen. The windows cannot be overlapped in record / SPOT path.

The picture type of record / SPOT path in static mode is controlled by the RP\_PIC\_TYPE / SP\_PIC\_TYPE (0x215, 0x295) register. For each of the picture type, the windows are arranged as follows.

- **PIC\_TYPE of 0 / 1:** The record / SPOT module output 1 field/frame from each of the channel specified by CHNUM0 ~ CHNUM3 (0x21D, 0x21E for record, and 0x2AD, 0x2AE for SPOT). There is a control CH\_CYCLE (0x215 for record, 0x2A5 for SPOT) used to control how many ports are interleaved. A CH\_CYCLE setting of m allows m channels to be interleaved as specified in CHNUM0 ~ CHNUMm-1. The CHNUMm through CHNUM3 will be ignored. A CH\_CYCLE "0" represents m=4.
- **PIC\_TYPE of 2/3/4/5:** The record captures 4 channels to form a 4-window screen with CHNUM0 represents the upper left window, CHNUM1 represents the upper right window, CHNUM2 represents the lower left window, and CHNUM3 represents the lower right window. CH\_CYCLE should be set to 1 for these types.
- **PIC\_TYPE of 6/7:** The record path captures 2 channels to form a 2-window screen, with CHNUM0/2 representing the left window, and the CHNUM1/3 representing the right window. The CH\_CYCLE can be set to 2 to interleave 4 channels into 2 fields.

An additional SPOT path 16-window QCIF mode allows all 16 ports of the 4 chip cascade configuration to be shown on a single output with 16 QCIF window size on the SPOT output. In this case, the channels are static from field to field, just like display path. To use this mode, the user set the SP\_16 register (0x2C0) to 1, and specify the location of the output windows with SP\_16\_WINNUM0 ~ SP\_16\_WINNUM3 (0x2C1, 0x2C2) for each of the port 0 ~ 3.

### **Record/SPOT Switch Control (SM\_EN = 1)**

#### **Switch Queue**

The dynamic switch mode is designed to allow multiple channels to share the output frame rate through flexible way of frame/field interleaving of "Picture Type" described previously at the "Multi-channel Video Format" section. The "Picture Type" can be one of the 8 types in Figure 15 and can change from field / frame to field / frame. To achieve this, an internal Switch Queue (1024 entries in the record path and 16 entries in the SPOT path) is used to specify the "Picture Type", "Channel IDs", the Capturing Field (Odd or Even) of each field/frame. The input videos are multiplexed according to the Switch Queue to generate the output multi-channel video stream. The Switch Queue read pointer increments once per field for "Picture Type" of the Field Mode type, and increment once per frame when the "Picture Type" being one of the Frame Mode type. The definition of a switch queue entry is shown in Table 6 for record path and Table 7 for SPOT path.



TABLE 6. SWITCH QUEUE ENTRY DEFINITION OF RECORD PATH

SWITCH QUEUE ENTRY BIT RANGE	FUNCTION
3 : 0	CHNUM0 (upper left window) CHIP_ID + PORT_ID
7 : 4	CHNUM1 (upper right window) CHIP_ID + PORT_ID
11 : 8	CHNUM2 (lower left window) CHIP_ID + PORT_ID
15 : 12	CHNUM3 (lower right window) CHIP_ID + PORT_ID
19 : 16	CHANNEL DISABLE
22 : 20	PICTURE_TYPE
23	STROBE_FIELD
27 : 24	Record OSG0 Control
31 : 28	Record OSG1 Control

TABLE 7. SWITCH QUENE ENTRY DEFINITION OF SPOT PATH

SWITCH QUEUE ENTRY BIT RANGE	FUNCTION
3 : 0	CHNUM0 (upper left window) CHIP_ID + PORT_ID
7 : 4	CHNUM1 (upper right window) CHIP_ID + PORT_ID
11 : 8	CHNUM2 (lower left window) CHIP_ID + PORT_ID
15 : 12	CHNUM3 (lower right window) CHIP_ID + PORT_ID
19 : 16	CHANNEL DISABLE
22 : 20	PICTURE_TYPE
23	STROBE_FIELD

With the switch queue defined, the output video can change configuration from field / frame to field / frame. For example, the first field can be a whole screen channel (e.g. picture type 0), the second field can be a quad-CIF screen (e.g. picture type 2), while the third/fourth fields being picture type 5. A switch queue size register RP\_SQ\_SIZE / SP\_SQ\_SIZE (0x20E, 0x20F for record and 0x29E for SPOT) specifies the length of the queue. The use of the switch queue will loop from the first entry to the SQ\_SIZE entry and starts over again.

### Switch Queue Configuration

To write an entry in the Switch Queue, the MCU configures the RP\_SQ\_ADDR (0x20D/0x20F) for record, SP\_SQ\_ADDR (0x29D) for SPOT, RP\_SQ\_SIZE (0x20E/0x20F) for record, RP\_SQ\_SIZE (0x29F), set a "1" to RP\_SQ\_WR (0x208) for record, SP\_SQ\_WR (0x298) for SPOT, Then write a queue entry data to RP\_SQ\_DATA (0x209/0x20A/0x20B/0x20C) for record, SP\_SQ\_DATA (0x299/0x29A/0x29B) for SPOT. Once all these are

done, the MCU sets a “1” to RP\_SQ\_CMD (0x208) for record, or SP\_SQ\_CMD (0x298) for SPOT. The RP\_SQ\_CMD/SP\_SQ\_CMD bit will be cleared automatically after updating queue. A queue entry can be read similarly, except setting set a “0” to RP\_SQ\_WR (0x208) for record, SP\_SQ\_WR (0x298). Once the RP\_SQ\_CMD/SP\_SQ\_CMD is issued, the MCU will read back the queue entry data from RP\_SQ\_DATA/SP\_SQ\_DATA registers.

## WINDOW CONFIGURATION

### Display Window Configuration

Display path involves many different modes, and requires a lot of configuration / setting through registers. Whenever there is a change in setting, some procedures need to be followed in order to make sure the pictures shown are correct. Figure 18 below shows the sequence to change the display mode window configuration. Before any change is made in register 0x250 ~ 0x28F, always set the channel enable to ‘0’ for the corresponding window in 0x250, 0x258, 0x260, 0x268, 0x270, 0x278, 0x280, 0x288. Proceed to change the configuration in 0x250 ~ 0x28F. Once all the change are made, turn the channel enable bit to ‘1’ to resume the window display.

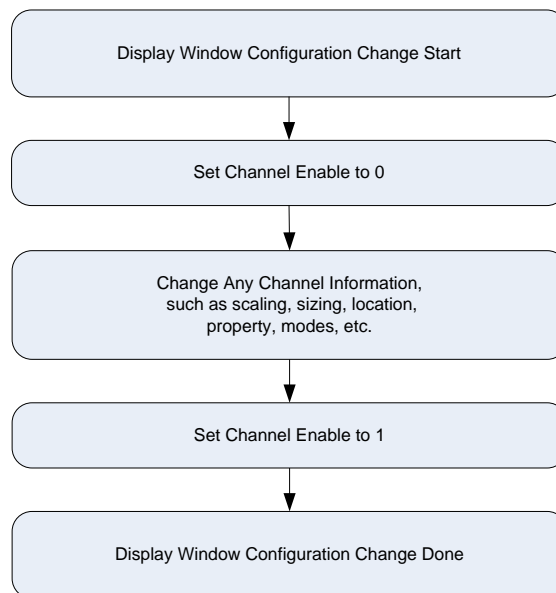

FIGURE 18. THE SEQUENCE TO CHANGE DISPLAY WINDOW CONFIGURATION

### Record/SPOT Path Configuration Change

Record / SPOT paths also support various types of modes, and there are a lot of configuration registers to set in order to change the mode. The record / SPOT path have a little bit different way of handling configuration change. To make any mode change, simply change whatever configuration registers of the windows, such as switch queue change, scaling change, channel number change, etc. After all the changes are done, the MCU should issue a CONFIG\_DONE signal (0x208 for record, 0x298 for SPOT). The record/SPOT control will resume normal operation.

## VIDEO WINDOW CONTROL

In addition to the window size / location configuration, there are other controls and image enhancement features in display / record / SPOT path.

## Background Control

The union of all active channel regions can be called as active region and the rest region except active region is defined as background region. The TW2851 supports background overlay with the overlay color controlled via the DP\_BGND\_COLR (0x230) registers for display, RP\_BGND\_COLR (0x201) for record, and SP\_BGND\_COLR (0x291) for SPOT.

## Border Control

The TW2851 display path can overlay channel boundary on each channel region using the DP\_BORDER\_EN (0x24E). The boundary color of a channel can be selected through the DP\_BORDER\_COLR (0x24C) register. The border can be blinked via the DP\_BORDER\_BLINK (0x23A) register when DP\_BORDER\_EN is high. The border color will change between the DP\_BORDER\_COLR and the background color (DP\_BGND\_COLR) when the DP\_BORDER\_BLINK is set. The blink period is controlled through a blinking timer in register BLINK\_PERIOD at 0x620.

The SPOT path also supports the border through SP\_BORDER\_EN at register 0x291 and SP\_BORDER\_COLR at register 0x292.

## Blank Control

Each channel can be blanked with specified color when NOVIDEO signal is detected for the channel. The content when the NOVIDEO is detected is determined by auto blank registers (RP\_BLNK\_DIS at 0x201 for record, and SP\_BLANK\_MODE at 0x291 for SPOT). For display, this can be either a fixed blank color, the last captured image, or last capture image with blink border. For record and SPOT, this can be either the last captured image or a fixed blank color. The blank color is determined by the blank color registers (DP\_BLANK\_COLR at 0x230 for display path, RP\_BLANK\_COLR at 0x201 for record path, and SP\_BLANK\_COLR at 0x291 for SPOT). The video window can be forced to blank color even though the NOVIDEO signal is 0. This is done by RP\_BLNK\_n (0x210 ~ 0x213) for record, and SP\_BLNK\_n (0x2A0 ~ 0x2A3 for SPOT).

## Display Freeze Control

In Freeze Mode, the write control stop writing any field / frame into the external DDR DRAM. With the read control circuit still reading the latest picture in the DRAM, the result is a frozen still picture. Both display and SPOT paths support freeze mode. The display path controls the freeze through 0x250, 0x258, 0x260, 0x268, etc., for each window. The SPOT path controls the freeze mode through 0x2A0, 0x2A1, 0x2A2, and 0x2A3.

## Horizontal / Vertical Mirroring

The TW2851 supports image-mirroring function for horizontal and/or vertical direction. The horizontal mirroring is achieved via the DP\_MIR\_V\_n / DP\_MIR\_H\_n (0x251, 0x259, 0x260, 0x269, etc.) for display, RP\_MIR\_V\_n / RP\_MIR\_H\_n (0x210, 0x211, 0x212, 0x213) for record, and SP\_MIR\_V\_n / SP\_MIR\_H\_n (0x2A0, 0x2A1, 0x2A2, 0x2A3) for SPOT. It is useful for a reflection image in the horizontal and vertical direction from dome camera or car-rear vision system.

## IMAGE ENHANCEMENT PROCESSING

### 2D De-interlacing

The TW2851 has a built-in 2D de-interlacer to process interlaced video inputs to generate progressive video from each incoming field before sending out to the VGA and LCD interface. The frame rate is doubled after the de-interlacing. A proprietary low angle compensation circuitry adaptively corrects the interpolation process to result in smooth video rendering.

Most of the de-interlacing control registers are fine tuned, and should be kept as the default value. The 2D de-interlacer control registers are located at 0x490 ~ 0x49C.

### VGA Up-scaling Function

The TW2851 supports high performance up-scaling function in the vertical and horizontal direction for the display VGA path. The TW2851 provides high quality up-scaling characteristics using a high performance

interpolation filter and image enhancement technique. The upscaler control registers are located at 0x4A0 ~ 0x 4AE. The up-scaler may scale up the input from a selected area (zooming area) within the whole active video frame. With this, a zoom function is achieved. The zooming area is configured by using registers from 0x240 ~ 0x245.

**Adaptive Black / White Stretch**

This feature expands the dynamic range of the input image based on the video frame statistics and creates more vivid image impression.

**Sharpness Control**

TW2851 provides both horizontal and vertical sharpening circuit to provide clear images on the panel.

**RGB Gamma Correction**

TW2851 has built-in independent RGB 10-bit Gamma RAM for the purpose of table lookup Gamma correction.

## Video Output

TW2851 supports both analog and digital video outputs. Analog outputs include: display VGA output, two CVBS output shared by display, record, and spot path. The digital outputs include: display RGB output, display cascade output, display BT1120 output, record output 1 and 2 in 656 format, and SPOT output in 656 format.

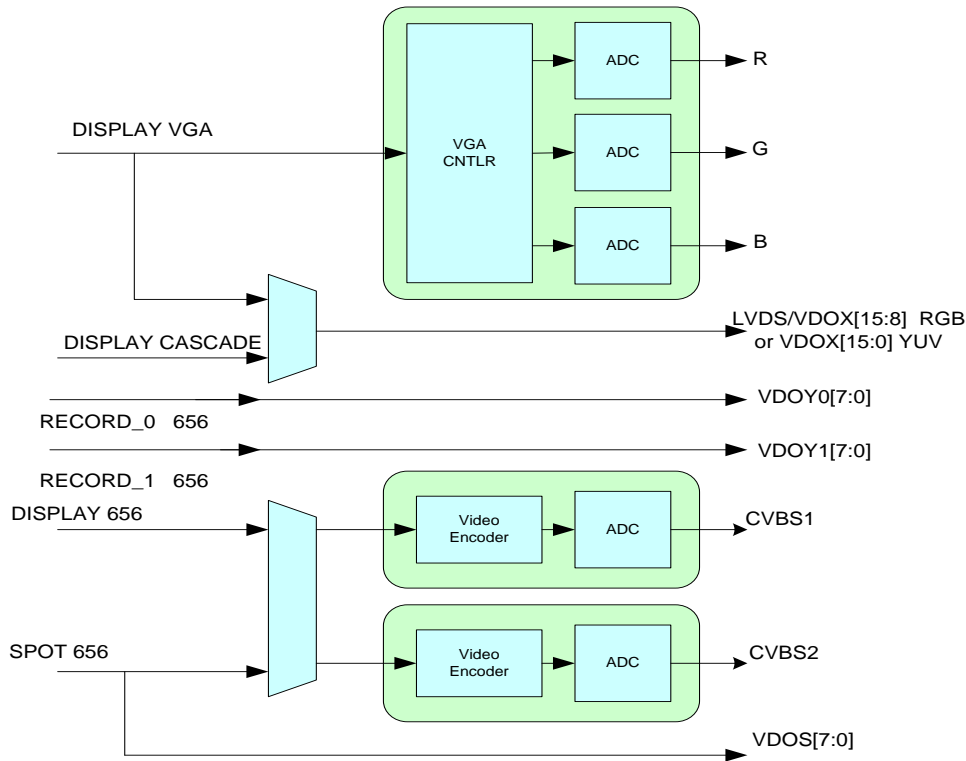

FIGURE 19. THE VIDEO OUTPUT BLOCK DIAGRAM

### ANALOG VGA/RGB VIDEO OUTPUT

The TW2851 incorporate 3 higher performance DACs to provide analog RGB component output for display VGA interface. In addition to the RGB component, the VGA VS / HS signal is also generated. The VGA output supports various resolutions from VGA (640x480), SVGA (800x600), XGA (1024x768), SXGA (1280x1024), and WXGA (1440x900). The VGA output video went through an on-chip 2D de-interlacer module to convert the interlaced video signal into progressive and an up-scaler function to scale the internal 4D1 resolution video into a screen size larger than 4D1.

### CVBS VIDEO OUTPUT

The TW2851 supports analog video output using two built-in video encoders, which generates composite video with a 10 bit DAC. The sources of the video encoder inputs are flexibly selectable from display and SPOT path by setting VE\_SEL (0x2D7, 0x2D8). Whatever the incoming video sources are, they have to be running at 27 MHz in order to use the video encoder for CVBS output. The incoming digital video are adjusted for gain and offset according to NTSC or PAL standard. Both the luminance and chrominance are band-limited and interpolated to 27MHz sampling rate for digital to analog conversion. The NTSC output can be selected to include a 7.5 IRE pedestal. The TW2851 also provides internal test color bar generation.

### Output Standard Selection

The TW2851 on-chip video encoders support various video standard outputs via the VE\_PAL\_NTSC and VE\_FSCSEL (0x2D0), VE\_PHALT, VE\_PED (0x2D1) registers as described in the following Table 8.

TABLE 8. ANALOG OUTPUT VIDEO STANDARDS

FORMAT	SPECIFICATION			REGISTER			
	LINE/FV (HZ)	FH (KHZ)	FSC (MHZ)	PAL_NTSC	ENC_FSC	ENC_PHALT	ENC_PED
NTSC-M	525/59.94	15.734	3.579545	0	0	0	1
NTSC-J							0
NTSC-4.43	525/59.94	15.734	4.43361875	0	1	0	1
NTSC-N	625/50	15.625	3.579545	1	0	0	0
PAL-BDGHI	625/50	15.625	4.43361875	1	1	1	0
PAL-N							1
PAL-M	525/59.94	15.734	3.57561149	0	2	1	0
PAL-NC	625/50	15.625	3.58205625	1	3	1	0
PAL-60	525/59.94	15.734	4.43361875	0	1	1	0

If the VE\_FDRST (0x2D1) register is set to “1”, phase alternation can be reset every 8 field so that phase alternation keeps same phase every 8 field. The polarity of horizontal, vertical sync and field flag can be controlled by the VE\_HSPOL, VE\_VSPOL and VE\_FLDPOL (0x2D1) registers respectively. The TW2851 can detect field polarity from vertical sync and horizontal sync via the VE\_FLD (0x2D0) register or can detect vertical sync from the field flag via the VE\_VS (0x2D0) register. The detailed timing diagram is illustrated in Figure 20.

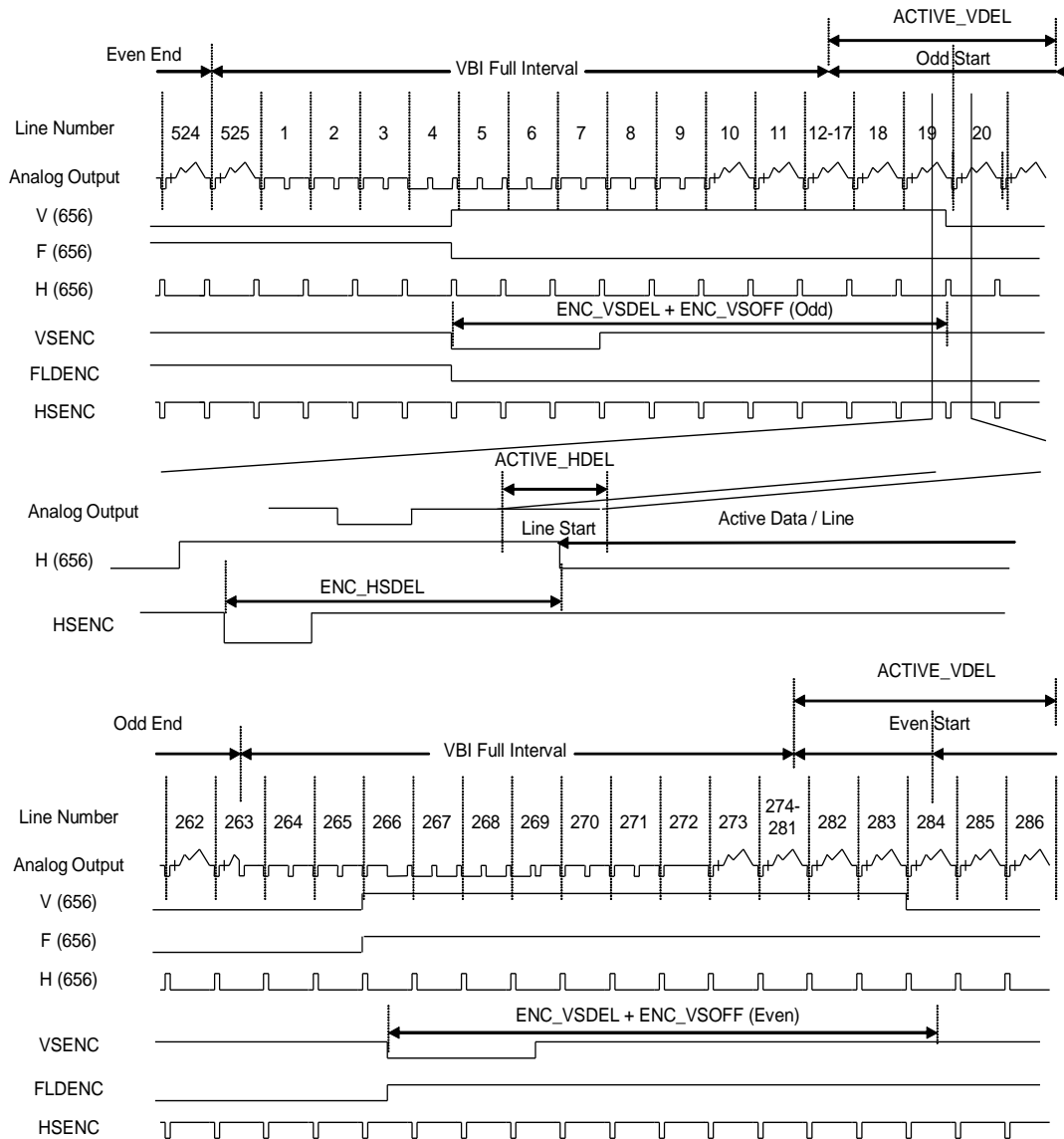
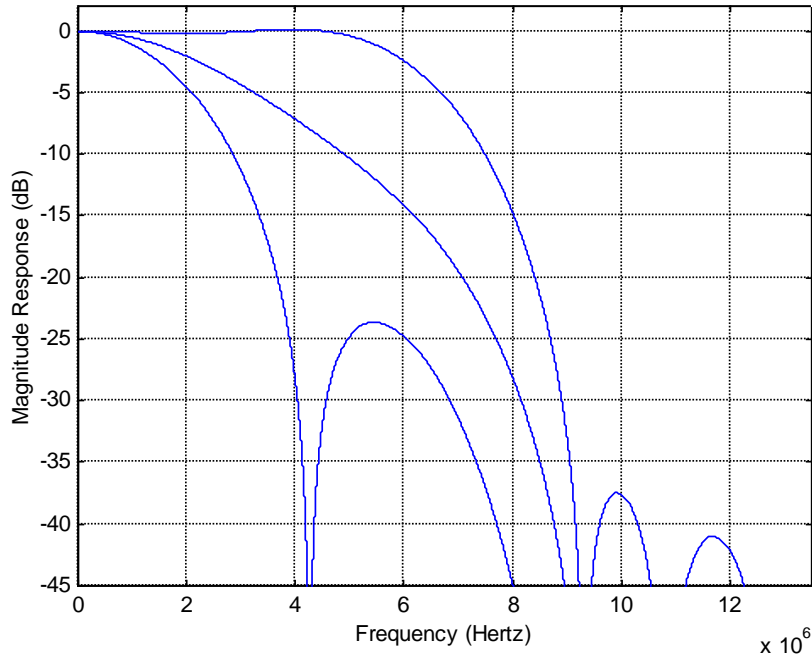

FIGURE 20. HORIZONTAL AND VERTICAL TIMING CONTROL

TW2851 has the VE\_HSDDEL (0x2D2), VE\_VSDEL and VE\_VSOFF (0x2D3) registers to control the related signal timing as shown in the above figure. Likewise, by controlling the VE\_ACTIVE\_VDEL (0x2D4) and VE\_ACTIVE\_HDEL (0x2D5) registers, the active video period can be shifted on horizontal and vertical direction independently. The shift of active video period produces the cropped video image because the timing signal is not changed even though active period is moved. So this feature is restricted to adjust video location in monitor for example.

**Luminance Filter**

The bandwidth of luminance signal can be selected via the VE\_YBW (0x2D7, 0x2D8) register as shown in Figure 21.



**FIGURE 21. CHARACTERISTICS OF LUMINANCE FILTER**

**Chrominance Filter**

The bandwidth of chrominance signal can be selected via the VE\_CBW (0x2D7, 0x2D8) register as shown in Figure 22.

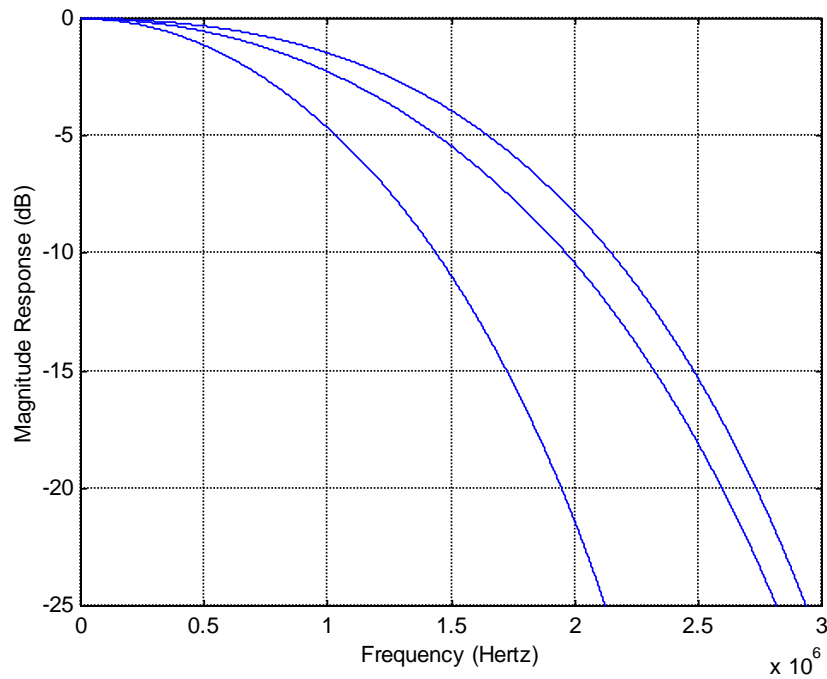

**FIGURE 22. CHARACTERISTICS OF CHROMINANCE FILTER**



## Digital-to-Analog Converter

The digital video data from video encoder is converted to analog video signal by DAC (Digital to Analog Converter). A simple reconstruction filter is required externally to reject noise as shown in the Figure 23.

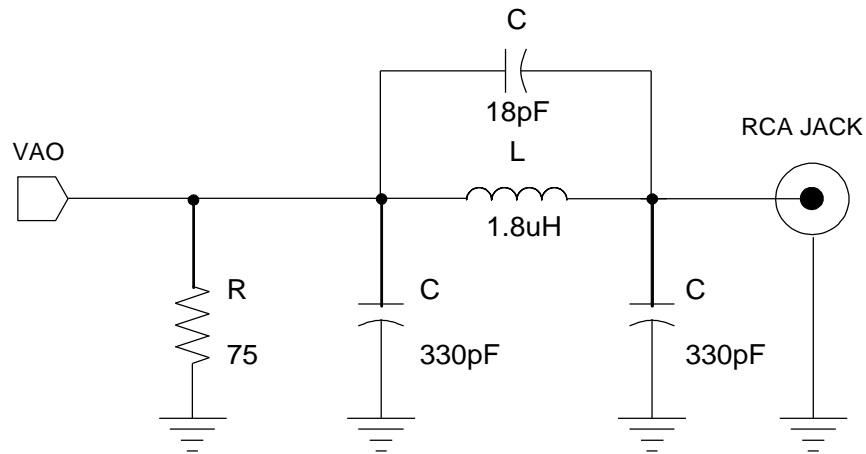

FIGURE 23. EXAMPLE OF RECONSTRUCTION FILTER

## DIGITAL OUTPUT

The TW2851 display digital format includes the RGB output, YUV output and cascade output output, etc.

### Display RGB Output

The Display VGA RGB output supports various resolutions from VGA (640x480), SVGA (800x600), XGA (1024x768), SXGA (1280x1024), and WXGA (1440x900). The VGA output video went through a on-chip 2D de-interlacer module to convert the interlaced video signal into progressive. When in digital format, the RGB data is 24 bit wide. The HS / VS signals are generated together with the 24 bit data.

### Display YUV Output

The display YUV output is a 422 YUV interface of 16 bit wide digital interface. The YUV output video does not go through de-interlacer. The output resolution is programmable, and can support up to 1080I resolution. This allows the user to use external 3D de-interlacer if a higher picture quality is needed. The HS / VS signals are generated, even though a BT1120 SAV/EAV timing signal is also embedded in the video data stream.

### Display Cascade Output

The display cascade output is an 8-bit bus with built-in SAV/EAV timing control similar to the BT. 656 format, however running at either 27 MHz or 108 MHz. With this, the display cascade path is able to support either 1 D1 (720x480 / 576) or 4 D1 (1440x960) display size. This allows the cascade path to run the native display buffer resolution of supporting 4 D1 without downscaling and sacrifice the picture quality.

### Record BT 656 / 601 Output in Field Interleave Format

The record path can support up to 2 656 digital output ports, 1 port 601, or 1 port BT. 1120-like format. . The BT. 1120-like output is very similar to 656, except it is 16-bit wide and the resolution is 1440 x 960 rather than 720x480 / 720x576. TW2851 supports all these formats with the configuration as shown in the Table 9 below. When using 1 output port of BT. 656, the frequency can run up to 54MHz to carry 2 times D1 frames rates. If 2 port BT. 656, 601, format are used, only up to 27 MHz each port is supported. If BT. 1102 format is used, the port frequency is always 54 MHz. The record clock is set by register RP\_CLK\_SEL at 0x200. Note that when 2 BT. 656, 601, or 1120 formats are used, always set the RP\_CLK\_SEL register to be twice the frequency of the port frequency. E.g., in order to setup a 27 MHz output frequency at the output port, the RP\_CLK\_SEL should be set to 54 MHz whenever RP\_2\_656 is "1". The internal circuit in the record path will divide the clock down to 54 MHz at the output.

TABLE 9. DIGITAL RECORD OUTPUT PORT CONFIGURATION

PORT TYPE	PORT NUMBER	MAX FIELD RATE PER PORT	PORT FREQUENCY	RP_CLK_SEL
BT. 656	1	120	27 ~ 54	1 ~ 2
BT. 656	2	60	27	1 ~ 2
BT. 601	1	120	13.5 ~ 27	1 ~ 2
BT. 1120-like	1	60	54	3

The active video level of the ITU-R BT.656 can be limited to 1 ~ 254 via the RP\_LIM\_656 (0x202) register. In case that channel ID is located in active video period, the RP\_LIM\_656 should be set to low for proper digital channel ID operation.

The following Table 10 shows the ITU-R BT.656 SAV and EAV code sequence.

TABLE 10. ITU-R BT.656 SAV AND EAV CODE SEQUENCE

	LINE		CONDITION			FVH			SAV/EAV CODE SEQUENCE			
	FROM	TO	FIELD	VERTICAL	HORIZONTAL	F	V	H	FIRST	SECOND	THIRD	FOURTH
60Hz (525Lines)	523 (1*1)	3	EVEN	Blank	EAV	1	1	1	0xFF	0x00	0x00	0xF1
					SAV			0				0xEC
	4	19	ODD	Blank	EAV	0	1	1	0xFF	0x00	0x00	0xB6
					SAV			0				0xAB
	20	259 (263*1)	ODD	Active	EAV	0	0	1	0xFF	0x00	0x00	0x9D
					SAV			0				0x80
	260 (264*1)	265	ODD	Blank	EAV	0	1	1	0xFF	0x00	0x00	0xB6
					SAV			0				0xAB
	266	282	EVEN	Blank	EAV	1	1	1	0xFF	0x00	0x00	0xF1
					SAV			0				0xEC
	283	522 (525*1)	EVEN	Active	EAV	1	0	1	0xFF	0x00	0x00	0xDA
					SAV			0				0xC7
50Hz (625Lines)	1	22	ODD	Blank	EAV	0	1	1	0xFF	0x00	0x00	0xB6
					SAV			0				0xAB
	23	310	ODD	Active	EAV	0	0	1	0xFF	0x00	0x00	0x9D
					SAV			0				0x80
	311	312	ODD	Blank	EAV	0	1	1	0xFF	0x00	0x00	0xB6
					SAV			0				0xAB
	313	335	EVEN	Blank	EAV	1	1	1	0xFF	0x00	0x00	0xF1
					SAV			0				0xEC
	336	623	EVEN	Active	EAV	1	0	1	0xFF	0x00	0x00	0xDA
					SAV			0				0xC7
	624	625	EVEN	Blank	EAV	1	1	1	0xFF	0x00	0x00	0xF1
					SAV			0				0xEC

When 601 or 1120-like format is used, only 1 port is supported. The frequency can run up to 54 Mhz. In either 656 / 601, the channel ID information is embedded in the VBI area that can be extracted by the external CODEC, or by the playback channel ID decoder.

#### Record BT 656 Output in Byte-Interleave Format

The TW2851 byte-interleave output runs at 54 MHz, such that each of the VDOY0 and VDOY1 carry 2 D1 output. With this, a total of 4 D1 output directly from video decoder is available to the external CODEC. When byte interleave is used, the CLK0Y0 polarity can be set to be the reverse of CLK0Y1 using CLK0Y0\_POL, CLK0Y1\_POL (0x2FB) such that one video channel can be latched with the rising edge of CLK, and the other channel from falling edge of CLK. The delay of CLK0Y0, CLK0Y1 can be adjusted with CLK0Y0\_DLY and CLK0Y1\_DLY (0x2FE).

## SPOT 656 Output

The SPOT path can support one 656 digital output port at 27 MHz. This output can be used for both external CODEC, or used as the SPOT cascade output to the next TW2851 chip.

## TFT PANEL SUPPORT

The TW2851 supports varieties of active matrix TFT panels with single / dual channel LVDS as well. It supports panel with resolution up to 1366x768 or WXGA resolution.

## Dithering

If the color depth of the input data is larger than the LCD panel color depth, the TW2851 can be set to dither the image. Up to four bits of apparent color depth can be added with the internal dithering ability of the TW2851. This allows LCD panels with 4, 6 or 8 bits per color per pixel to display up to 16.8 million colors and LCD panels with 3 bits per color per pixel to can display up to 2.1 million colors.

The TW2851 has both spatial and frame modulation dithering. When dithering with the least significant 4-bits of input data the TW2851 uses spatial modulation with 4x4 blocks of pixels. When dithering with the least significant 1 to 3 bits of input data, the TW2851 uses either spatial modulation with 2x2 pixel blocks, or frame modulation.

## Power Management

The TW2851 supports panel power sequencing. Typical TFT panels require different parts of the panel power to be applied in the right sequence to avoid premature damage to the panel. Pins are provided to control the panel backlight generator, digital circuitry and panel driver, separately. The TW2851 controls the power up and power down sequence for the LCD panels. The time lapses between different stages of the sequence are independently programmable to meet various power sequencing requirements.

The TW2851 also supports VESA™ DPMS for monitor power management. It can detect the DPMS status from input sync signals and automatically change into On/Off mode. To support the power management, the TW2851 has three operating modes: Power On mode, Power Off mode, and Panel Off mode. All the DPMS power saving mode will be covered by the Power Off mode.

## Video Cascade

TW2851 supports cascade feature that allows up to 4 TW2851 chips to connect together and extend the port number up to 16 ports. Both the VGA / SPOT display modes supports cascade features. The cascade feature of each of the path can be individually turned on/off, depending on the user requirement. Figure 24 and Figure 25 show various way of cascade configuration of TW2851.

Each of the 4 chips cascaded together got assigned a unique chip ID (at 0x2F1). There is no special requirement on the sequence of chip ID as long as they are unique.

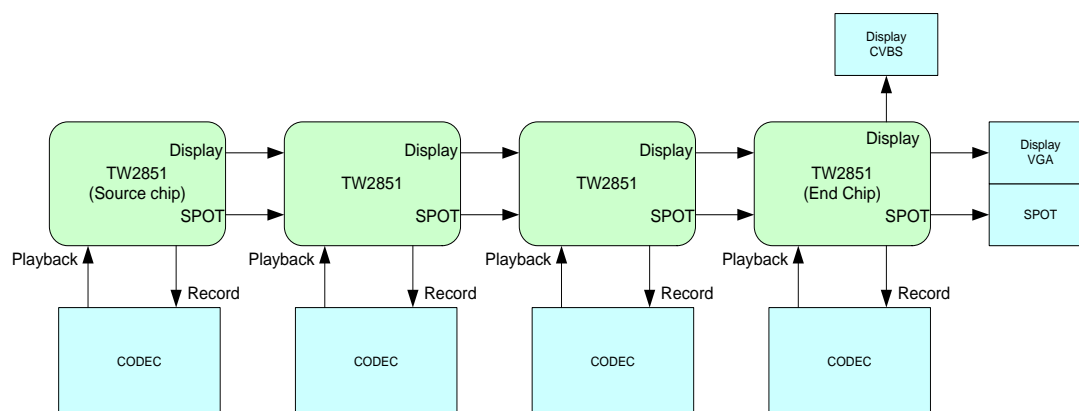

FIGURE 24

TW2851 CASCADE IN DISPLAY / SPOT PATHS

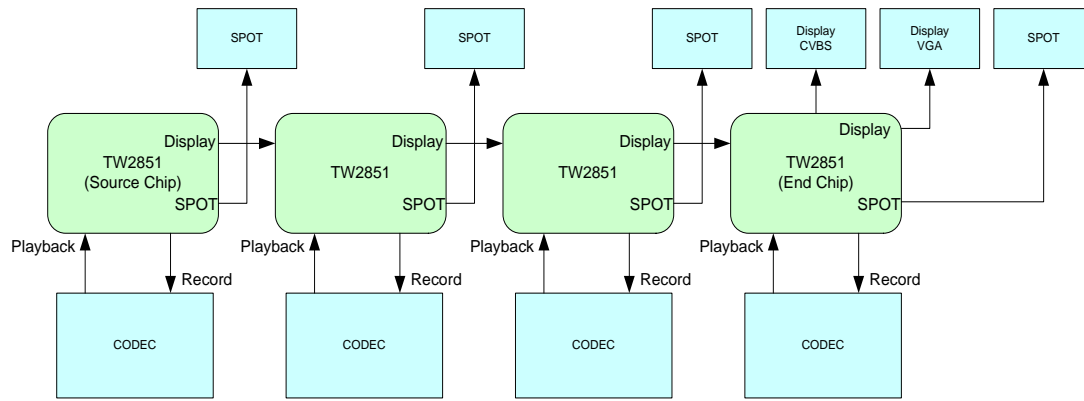

FIGURE 25. CASCADE IN DISPLAY PATH ONLY

## DISPLAY PATH

The TW2851 display cascade output goes through the VDOX bus using a 656 format. This cascade bus has clock CLKOX running at either 27 MHz or 108 MHz to carry video resolution of either single D1 (720 x 480) or 4 D1 (1440 x 960) pictures. The CLKOX frequency is selected by the DP\_CLK\_CSCD\_SEL register in 0x2F8. It can be 27 MHz, 108 MHz, or any clock from the PPLL output. The PPLL output is intended such that the VDOX bus output can also be used to drive external VGA / De-interlacer chip when the on-chip VGA is not to be used.

The cascade input is the VDIX / CLKIX bus connected to the VDOX[7:0] / CLKOX outputs of the previous stage.

## SPOT PATH

The TW2851 SPOT cascade output shared the pins of regular SPOT 656 output port. The clock output is the CLKOS, and is always 27 MHz. The VDOS[7:0] and CLKOS output drives the VDIS and CLKIS input pins of the next stage.

In order to enable SPOT path cascade, it is required to configure the SP\_CC\_EN (0x290[4:3]) register based on the location of the chip in the cascade chain. When a chip is not cascaded, SP\_CC\_EN is set to 0. When a chip is located at the source (or beginning) of the chain (most upstream one that outputs video and clock to next chip in the cascade), the SP\_CC\_EN is set to 10. When the chip is in the middle of the chain, SP\_CC\_EN is set to 11, and with the chip is at the end of the chain (most downstream one that outputs the CVBS SPOT video), the SP\_CC\_EN is set to 01. See Table 11 for a summary.

**TABLE 11. SP\_CC\_EN SETTING FOR THE RECORD PATH CASCADE**

<b>PORT TYPE</b>	<b>CASCADE SOURCE CHIP</b>	<b>CASCADE MIDDLE CHIPS</b>	<b>CASCADE END CHIP</b>	<b>NON-CASCADE</b>
<b>SP_CC_EN</b>	<b>10</b>	<b>11</b>	<b>01</b>	<b>00</b>

The SP\_CC\_EN can be set to 00 as in Figure 25, even though the display path is cascaded together.

## Channel ID

There are two channel ID encoders in the record path, and four channel ID decoders in the playback path. The channel ID CODEC follows the format as defined in this section.

### CHANNEL ID TYPES

The TW2851 supports four different channel IDs: User channel ID, Detection channel ID, auto channel ID and motion channel ID. The channel ID is composed of 8 bytes of User channel ID, 8 bytes of Detection channel ID, 8 bytes of Auto channel ID and 96 bytes of Motion Channel ID.

#### User Channel ID

The User channel ID is used for customized information like system information and date. Its content and format is defined by user and may be used for system information, date and so on. It is provided by the MCU through on-chip registers.

#### Detection Channel ID

The Detection channel ID is used for the detected information of current live input such as video loss state, blind and night detection information. The Detection channel ID consists of 2 bytes per chip with each channel of 4 bits for as is described in the following table. For cascaded application, there are 8 bytes of detection channel ID information reserved for all 16 channels. The order of those channel IDs is determined by the cascaded CHIP ID via the CHIP\_ID register in 0x2F1. That is, the master chip information (CHIP\_ID = "0") is output first and the slave chip information (CHIP\_ID = "3") output last. In pseudo 8 channel case, the motion detection information of channel n is shared by the VIN\_A and VIN\_B of channel n. The detection information is updated whenever a valid field/frame is output through the recording output.

TABLE 12. THE DETECTION CHANNEL ID INFORMATION

BIT	NAME	FUNCTION
3	NOVID	Video loss Information (0 : Video is Enabled, 1 : Video loss)
2	MOTN_DET	Motion Information (0: No Motion, 1: Motion)
1	BLIND_DET	Blind Information (0 : No Blind, 1 : Blind)
0	NIGHT_DET	Night Information (0 : Day, 1 : Night)

#### Auto Channel ID

In the Auto channel ID, there are 4 sets of 1-Byte data that contains 4 regions in a QUAD split image. The four bytes of Auto channel IDs are distinguished by their order. The first byte corresponds to the upper left region. The second byte corresponds to the upper right region. The third byte corresponds to the lower left region, and the fourth byte corresponds to the lower right region. Note that the 4 bytes of channel ID corresponds to the 4 regions in a field. It does not correspond to CH0, CH1, CH2, and CH3 of the 8 picture types in Figure 10.

The 1-byte Auto channel ID data is used to identify the current picture configuration. Its format is described in the following Table 13.

TABLE 13. AUTO CHANNEL ID BYTE 0 THROUGH BYTE 3 (FOR 4 REGIONS)

BIT	NAME	FUNCTION
7	PIC_TYPE[n]	Picture Type bit n, located at bit 7 of byte n in auto channel ID bytes
6	STROBE	STROBE represents a valid data in the specified channel window.
5	FLDMODE	Sequence Unit (0: Frame, 1: Field) – Backward compatibility only
4	ANAPATH	Analog switch information
[3:2]	CASCADE	Cascaded Stage Information – Backward compatibility only
[1:0]	VIN_PATH	Video Input Path Number

The bit 7 of auto-channel ID byte n is the bit n of PIC\_TYPE. The PIC\_TYPE is a code representing the picture type described in Figure 1. The coding of PIC\_TYPE[3:0] for each mode is shown in Table 14 below. The bit 6 is a STROBE used to denote the information update of each quad split area. If it is set to 1, then the video data in the quad split area is valid to be used in CODEC or playback path. Otherwise, the quad split area is to be ignored. The FLDMODE is used to denote the channel in the quad-split area is captured in either field or frame format. This piece of information is redundant to the PIC\_TYPE and can be derived from PIC\_TYPE, as shown in Table 14. The ANAPATH is used to identify the analog switch information of the channel in the quad split area. The ANAPATH information is required for pseudo 8channel MUX application using analog switch. The CASCADE is used to indicate the cascaded stage (chip ID) in chip-to-chip cascaded application. The VIN\_PATH information is used to indicate the video input channel.

TABLE 14. THE PICTURE TYPE CODE

CODE	DESCRIPTION	FLDMODE
0	D1 Field Mode	1
1	D1 Frame Mode	0
2	CIF Field Mode	1
3	CIF Frame Mode	0
4	CIF DVR Field Mode	1
5	CIF DVR Frame Mode	0
6	CIF Field Vx2 Mode	1
7	CIF DVR Vx2 Mode	1
8	Reserved	n/a
9	4D1 Frame Mode	0
10 ~ 15	Reserved	n/a



The following figure shows the example of Auto channel ID for various recording picture types.

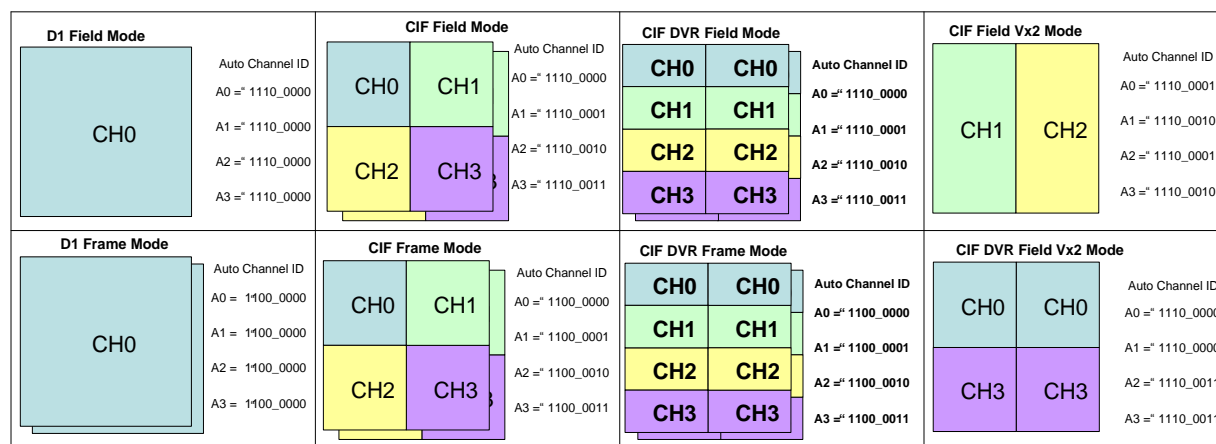

FIGURE 26. THE EXAMPLE OF AUTO CHANNEL ID FOR VARIOUS RECORD OUTPUT FORMATS

### Motion Channel ID

The Motion Channel ID is used to carry 4 sets of the 16x12 motion flags (192 bits, or 24 bytes) for each quad split regions on the field/frame picture. Similarly to the 4-byte of auto-channel ID, the first set of motion channel ID corresponds to the upper left region, the second set upper right, the third set lower left, and the fourth set lower right region. Total of 96 bytes of data are reserved in a motion channel ID. The motion channel ID is sent through a digital type channel ID in the VBI only. The analog type does not carry motion channel ID.

### CHANNEL ID ENCODING SETTING

The TW2851 has several channel ID encoders to put the channel ID into the VBI of the multi-channel video streams. The four types of channel IDs are embedded in the vertical blanking area in both analog and/or digital formats. The digital format is mainly used for video compression CODEC connected through the recording digital interface. The analog format is used if the recording device is an analog device such as a VCR.

The use of the digital channel ID has priority over analog channel ID. The analog channel ID format encoding is enabled via the ANA\_ID\_EN register and the digital type channel ID format encoding is operated via DIG\_ID\_EN register. The motion channel information is enabled by MOTN\_ID\_EN. Within the analog channel ID, each of the ID can be separately controlled by AUTO\_ID\_EN, DET\_ID\_EN, USER\_ID\_EN, ANA\_RPT\_EN, etc. All these registers are at address 0x216 and 0x2A6.

In addition, there are registers used to control the format/location of the channel ID within the VBI. The registers include the ANA\_CHID\_H\_OFST (0x217, 0x2A7) to define horizontal start offset, the CHID\_V\_OFSTE and CHID\_V\_OFSTO (0x21A, 0x21B, 0x2AA, 0x2AB) to define line offset between odd and even field, the CHID\_V\_OFST (0x21A, 0x2AA) to define line offset for channel ID, and the ANA\_CHID\_BW (0x21B, 0x2AB) to define pulse width for 1 bit data of analog channel ID. The magnitude of each bit is defined by the ANA\_CHID\_HIGH / ANA\_CHID\_LOW (0x218, 0x219, 0x2A8, 0x2A9) register.

Figure 27 shows the relationship between channel ID and register setting in channel ID encoder.

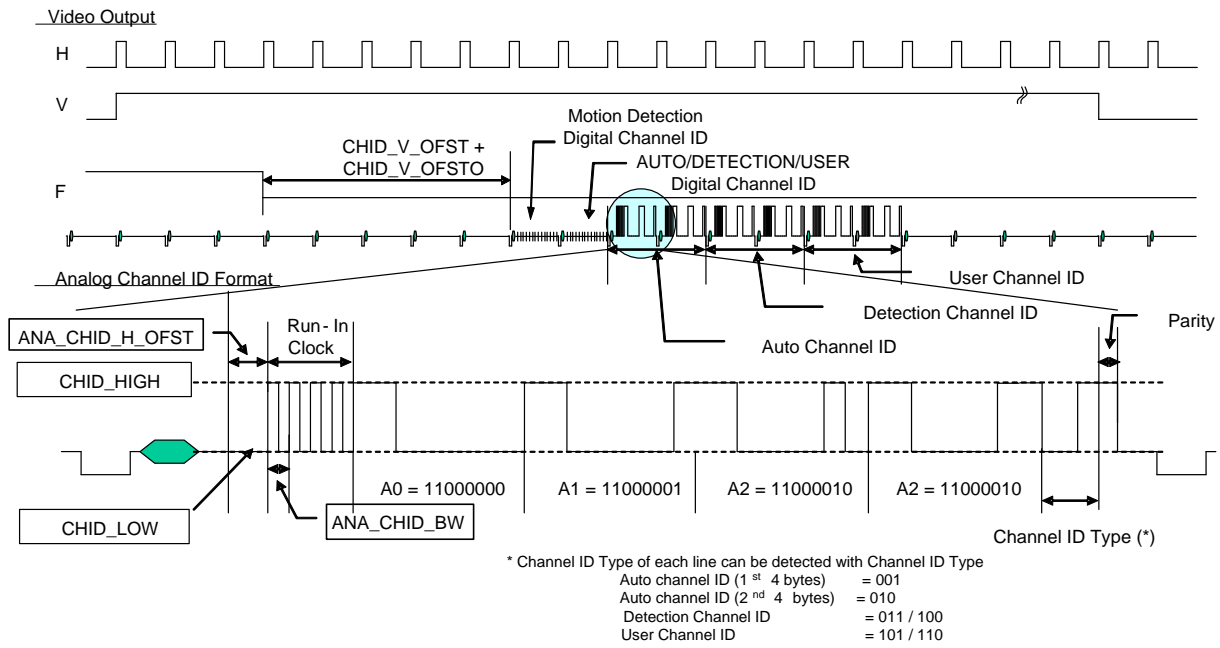

FIGURE 27. THE RELATED REGISTERS FOR CHANNEL ID ENCODING

### CHANNEL ID DECODING SETTING

The TW2851 supports the channel ID decoder to detect/decode the digital/analog channel ID format during VBI period. The decoding/detection of each channel ID detection can be enabled via the PBm\_DID\_EN, PBm\_AID\_EN, and PBm\_AUTO\_CHID\_DET registers at 0x12A ~ 0x13A.

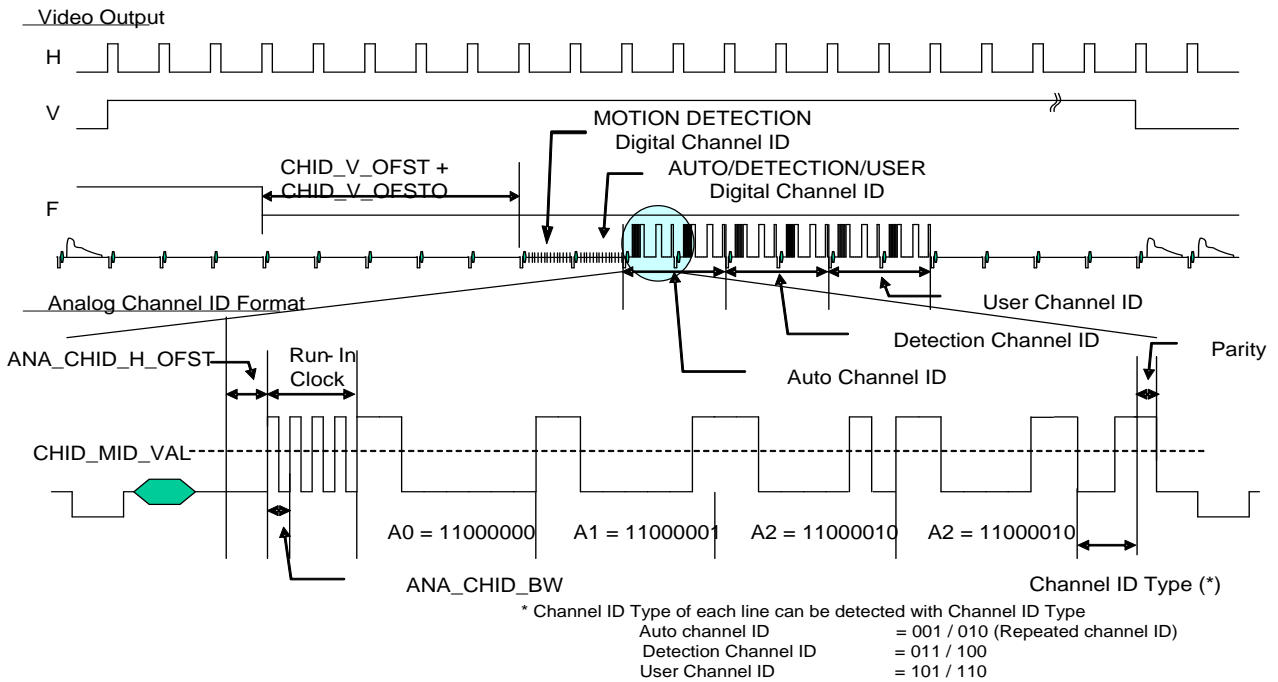

FIGURE 28. THE RELATED REGISTERS FOR CHANNEL ID DECODING

In order to provide accurate detection of analog channel ID decoder against noises from analog device such as a VCR source, the channel ID LPF can be enabled via the PB\_FLT\_EN (0x12A, 0x13A) register. The registers PB\_CHID\_MID\_VAL (0x12E, 0x13E) are used to define the threshold level between high and low for analog channel ID.

TW2851 channel ID decoder supports both automatic and manual channel ID detection modes to detect the analog channel ID. In the automatic channel ID detection mode, the channel ID decoder identifies the analog channel ID through a run-in clock embedded in the playback stream. The run-in clock insertion can be specified via the PBm\_RIC\_EN (0x12A, 0x13A) registers. In the manual channel ID detection mode, the decoder also use some preconfigured registers to specify the location of the analog channel ID, no matter the playback stream has a run-in clock embedded or not. These registers include the PB\_CHID\_H\_OFST (0x12C, 0x13C) to define horizontal start offset, the PB\_CHID\_FLD\_OS (0x12A, 0x13A) to define line offset between odd and even field, the PB\_CHID\_V\_OFST (0x12B, 0x13B) to define line offset for channel ID, the PB\_CHID\_LINE\_SIZE (0x12B, 0x13B) to define how many lines of channel ID is inserted, and the PB\_ANA\_CHID\_BW (0x12D, 0x13D) to define pulse width for 1 bit data.

This decoded channel ID information can be read through the PB\_CHID\_TYPE (0x1A5) or PB\_CHID\_STATUS registers (0x1A8 ~ 0x1AF). The PB\_CHID\_TYPE register specifies different types such as the Auto channel ID (CHID\_TYPE = "0"), or the detection/user channel ID (CHID\_TYPE = "1"). The PB\_CHn\_AUTO\_VLD (0x1A1), DET\_CHID\_VLD, USER\_CHID\_VLD, MOTION\_CHID\_VLD (0x1A2) registers can be used to indicate whether the auto channel ID, detection channel ID, user channel ID, and motion channel IDs are valid or not. In automatic channel ID detection mode, the line size and bit width can be read through the PB\_CHID\_LINE\_SIZE\_DET and PB\_ANA\_CHID\_BW\_DET (0x1A3) register. Figure 50 shows the relationship between channel ID and register setting.

## DIGITAL CHANNEL ID FORMAT

The four types of channel IDs are embedded in the vertical blanking area in both analog and/or digital formats. The use of the digital channel ID has priority over analog channel ID. It is useful for DSP applications to decode and extract the channel ID in digital format in just two lines of VBI. The digital channel ID is located before the six analog channel ID lines.

There are two lines of digital channel ID defined in TW2851. The first line is for motion channel ID. It is used to carry the motion detection flags of each channel. The second line is for auto/detection/user channel ID. Its format is compatible with TW2835/TW2837 digital channel ID format. The two lines of digital channel ID are located right before the analog channel ID. The register VIS\_LINE\_OS is used to determine the starting line of the first line of digital channel ID. The analog channel lines is right after the second digital channel ID line.

### The First Digital Channel ID Line

The motion detection digital channel ID carries up to 4 channels of motion flags (16x12 bits or 24 bytes each) within 1 digital channel ID line. Each channel corresponds to a quad split area on the window as was the case of auto-channel ID. There are total of 96 bytes of motion flags information.

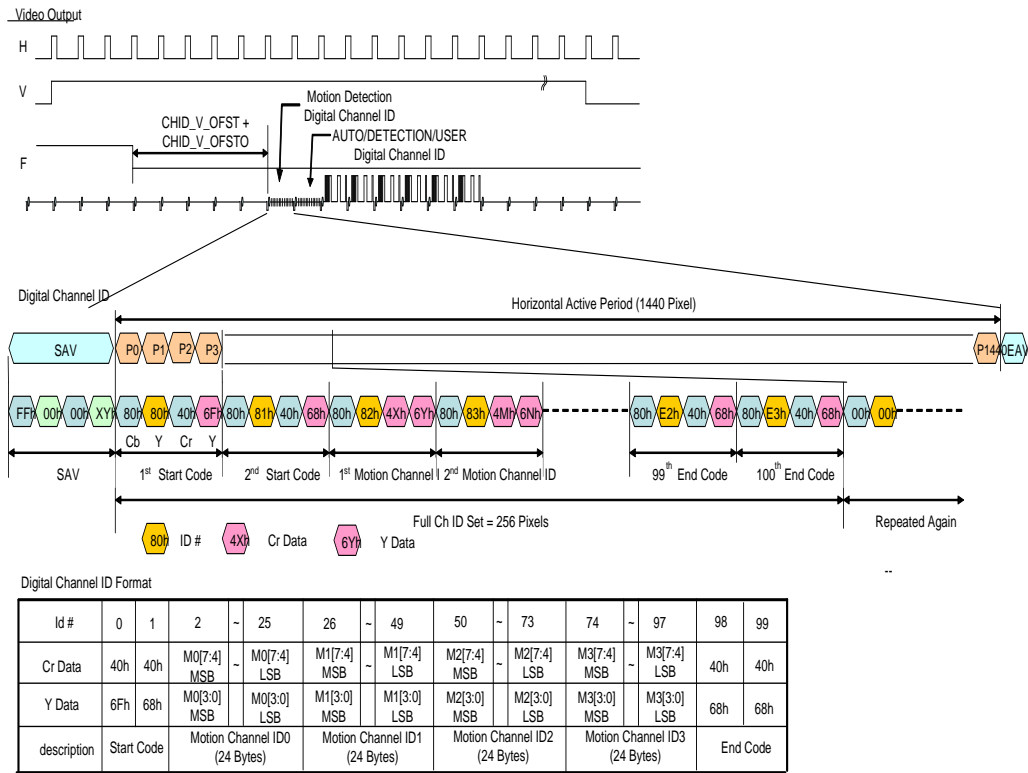
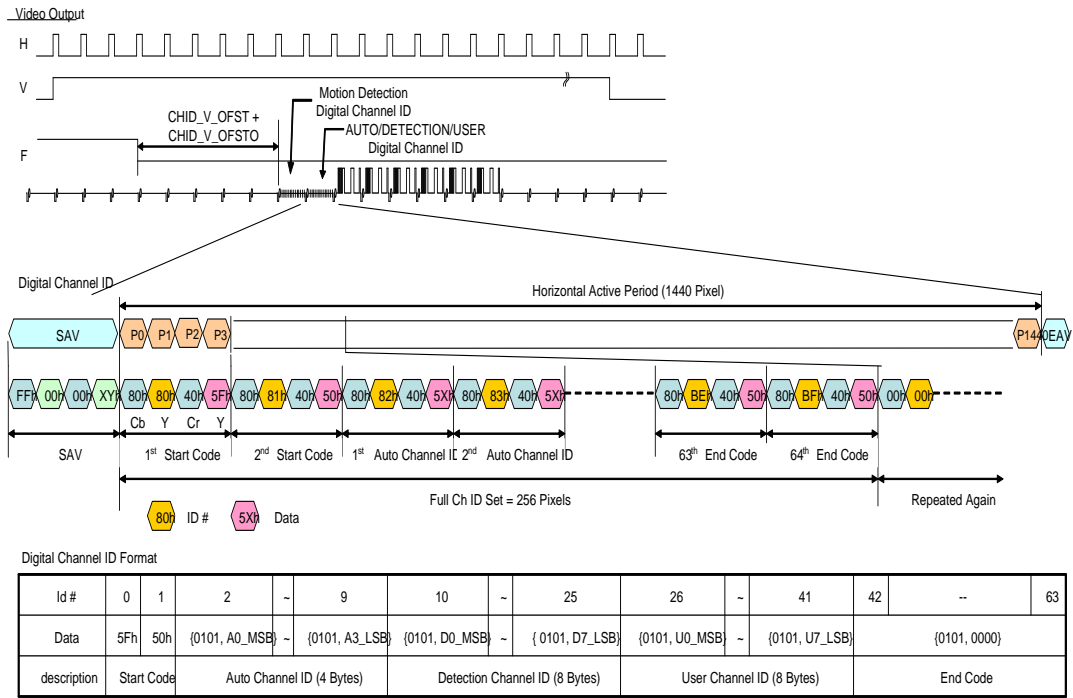

FIGURE 29. THE ILLUSTRATION OF THE MOTION DIGITAL CHANNEL ID IN VBI PERIOD

### The Second Digital Channel ID Line

The AUTO/DETECTION/USER digital channel ID is inserted in Y data in ITU-R BT.656 stream and composed of ID # and channel information. The ID # indicates the index of digital type channel ID including the Start code, Auto/Detection/User channel ID and End code. The ID # has 0 ~ 63 index and each channel information of 1 byte is divided into 2 bytes of 4 LSB that takes "50h" offset against ID # for discrimination. The Start code is located in ID# 0 ~ 1 and the first 4 bytes of Auto channel ID is situated in ID# 2 ~ 9. The Detection channel ID is located in ID # 10 ~ 25 and the User channel ID is situated in ID # 26 ~ 41. The End code occupies the others. The digital channel ID is repeated more than 5 times during horizontal active period. The following figure shows the illustration of the digital channel ID.



**FIGURE 30. THE ILLUSTRATION OF THE AUTO/DETECTION/USER DIGITAL CHANNEL ID IN VBI PERIOD**

## OSG

The TW2851 provides 5 OSG engines to overlay OSG contents on every output of the display, record, and SPOT path individually. The OSG engines have up to 7 layers of overlays on top of the video streams. The 7 layers are shown in Figure 11. The display OSGs (CVBS / VGA) have support all 7 layers. The Record OSGs do not support 2D box layer and the video border layer. However, the record OSGs have an additional feature allowing the OSG to switch from field to field so that the overlay content can be in sync with the field interleaving video content. The SPOT OSG does not support 2D layer either.

The configuration registers of all OSGs are arranged the same way to simplified the programming, except that they are in different page. The register page 5 are for VGA display OSG, page 6 for CVBS display OSG, page 7 for record port 0 OSG, page 8 for record port 1 OSG, and page 9 for SPOT OSG.

Each layer will be described in detail in the following sections.

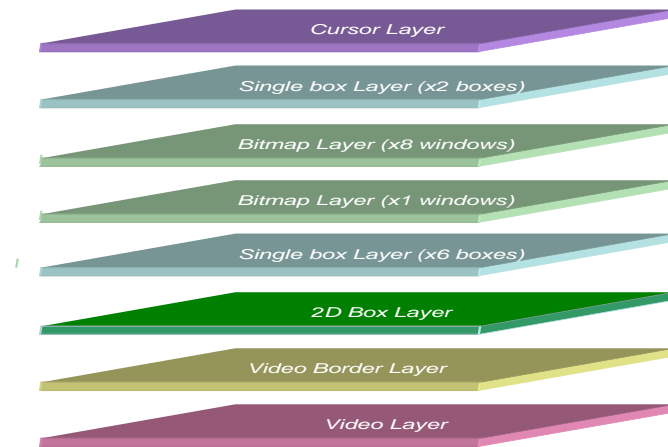

FIGURE 31. THE OVERLAY PRIORITY OF OSG LAYERS

### VIDEO BORDER LAYER

The video border layer is supported by the display CVBS / VGA OSG, as well as the SPOT OSG at the picture type 0, 1, 2, 3, and 16-window mode outputs.

For display path, the border is controlled by register `DP_BORDER_EN` (0x24E) to turn on/off the border. In addition, the border can start blinking (`DP_BORDER_BLINK` at 0x23A) when the NO-VIDEO signal of the corresponding channel is detected. The border color is controlled by `DP_BORDER_COLR` at register 0x24C.

For SPOT path, the border is turned on/off by register `SP_BORDER_EN` (0x291). The blink color is controlled by `SP_BORDER_COLR` (0x292). The border will blink when NO-VIDEO is detected when the register `SP_BLANK_MODE` (0x291) is set to "2".

The SPOT output is optionally used for network output port. In that case, the picture output is not meant for display purpose, and the video border does not apply. The `SP_BORDER_EN` should be turned off for those cases.

## 2-DIMENSIONAL ARRAYED BOX

The 2D arrayed boxes are mainly used to display the motion information, so the 2D boxes are available only in the display VGA/CVBS output path. Corresponding to the 8 video windows in the display path, there are eight 2D arrayed boxes to show the motion in the video windows. The 2D box OSG is tightly coupled with the motion detection circuit in the front-end video decoder.

Since there are 8 2D-boxes, the configuration of each individual 2D-box is done through an indirect write mechanism. The configuration register is applied to a specific 2D box if the corresponding bit in MDCH\_SEL is set to 1. For example, by setting MDCH\_SEL[0] to 1, a write to MDBOX\_EN at 0xm75 will turn on the MDBOX\_EN bit for the first 2D box. If MDCH\_SEL is 0xFF, then a write to MDBOX\_EN at 0xm75 will be set to all 2D boxes simultaneously.

The 2D boxes can be used to make table menu or display motion detection information. The mode is set by MDBOX\_MODE (0xm84). In order to turn on a 2D box, a global MDBOX\_EN at 0xm75 should be set to enable the 2D box OSG. In addition, a register bit MDBOXn\_EN (0xm85) is set to enable the specific 2D box out of the 8 boxes. The 2D arrayed boxes have programmable number of row and column cells up to 16 x 16. It is defined via the MDBOX\_HCELL and MDBOX\_VCELL (0xm8F). The horizontal and vertical location of left top is controlled by the MDBOX\_HOS and MDBOX\_VOS (0xm87 ~ 0xm89). The horizontal and vertical size of each cell is defined by the MDBOX\_HW and MDBOX\_VW (0xm8A ~ 0xm8C). The total size of 2D arrayed box will be the same as the sum of cells in row and column. The border of 2D arrayed box can be enabled by the MDBOX\_BNDEN (0xm8D) register to show a color controlled via the MD\_BNDRY\_COLR (0xm8D) register which selects one of 4 colors such as 0% black, 25% gray, 50% gray and 75% white.

The 2D arrayed box has a mask plane and a detection plane. The mask plane is used to show the “masking” area where the motion detection was not enabled. The detection plane represents the motion detected cell excluding the mask cells among whole cells. Both the masking information and the motion information are from the front-end motion detection circuit. The mask plane is enabled by the MDMASK\_EN (0xm85) register and the detection plane is enabled by the MDDET\_EN (0xm85) register. The color of mask plane is controlled by the MDMASK\_COLR (0xm86) register and the color of detection plane is defined by the MDDET\_COLR (0xm86) register which selects one out of 12 fixed colors or 4 user defined colors using the CLUT (0xm78 ~ 0xm83) registers. The plane can be transparently blended with video data by the MDBOX\_MIX (0xm85) and the alpha blending level is controlled as 25%, 50%, and 75% via the MDBOX\_ALPHA (0xm75) register. Even in the horizontal / vertical mirroring mode, the video data and motion detection result can be matched via the MDBOX\_HINV and MDBOX\_VINV (0xm85) registers.

TW2851 provides a special function to indicate cursor cell inside 2D arrayed box. The cursor cell is enabled by the MDCUR\_EN (0xm85) register and the displayed location is defined by the MDCUR\_HPOS and MDCUR\_VPOS (0xm8E) registers. Its color is a reverse color of cell boundary. It is useful function to control motion mask region. The Figure 32 shows an example of 2D arrayed box in both table mode and motion display mode.

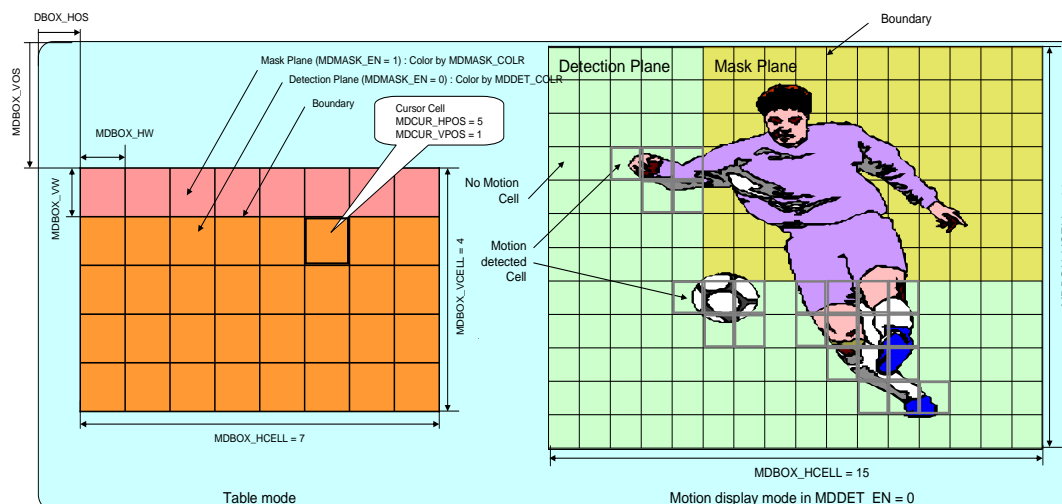

FIGURE 32. THE 2D ARRAYED BOX IN TABLE MODE AND MOTION DISPLAY MODE

## BITMAP LAYER

### Bitmap Buffer Structure

The TW2851 reserves a big space in the external DDR SDRAM for use by the bitmap layer. The bitmap buffer is specified by a starting OSG\_BASE address. For OSG write side, the base address is specified by OSG\_WRBASE\_ADDR (0x641). At the read side, each of the 5 OSGs (display VGA, display CVBS, record, SPOT, etc) has its own based address at 0xm36. The unit of the base addresses is 64 Kbytes. To avoid confusion, all of these base addresses should be set to the same value. The bitmap buffer also has a register OSG\_MEM\_WIDTH (0x640) to specify the bitmap buffer width, with the unit of 64 pixels. In this way, the bitmap buffer is organized in a 2-dimensional space such that all the burst fill / burst move can be done with respect to a 2-dimensional area, instead of a linear memory address. The internal format of bitmap buffer is in either the 444 RGB format (565), or the 422 YUV format. The 444 RGB format is used only in the VGA / LVDS path OSG. The 422 YUV format can be used in all OSGs, including display VGA/CVBS, record, spot, etc.

The use of bitmap buffer can be designed flexibly by the user. For example, some area can be assigned to be used by VGA OSG, other area by record OSG, and yet other area used as scratch area for storing re-usable font, logo, etc.

### OSG Bitmap Preparation

The TW2851 provides various acceleration functions to allow the external MCU to upload/manipulate the bitmap in the bitmap buffer efficiently.

### Bitmap Burst Fill

The MCU can unload the bitmap into the bitmap buffer by specifying an area in the bitmap buffer, and continuously write the pixel data into a register until the whole area is filled. To perform a bitmap burst fill, the MCU will follow the procedure below.

Check whether there is a previously unfinished burst command by checking the OSG\_OP\_START register (0x64F). If it is "1", then the MCU will wait until it is cleared, i.e., previous command finished.

Set the OSG\_OPMODE (0x642) to 0, which mean the bitmap burst fill mode.

Set the destination burst fill area in the bitmap buffer by setting OSG\_DST\_SV / OST\_DST\_SH (0x64B ~ 0x64D) for the upper left corner, and OSG\_DST\_EV / OSG\_DST\_EH (0x648 ~ 0x64A) for the right lower corner.

Set the OSG\_OP\_START to "1" to start a burst fill.



Write a 64-byte of pixel data into data register (In either 8-bit or 16-bit per write, depending on the parallel host interface data bus width)

Check the OSG\_BMWR\_BUSY (0x64F). If it is "1", then repeat this step after a certain delay time.

Repeat (5) to (6) until the whole area is filled. After the whole burst fill is finished, the OSG\_OP\_START will be cleared automatically to "0".

Note that if the MCU supports the WAIT signal through the host interface, then step (6) is not needed. The WAIT signal will automatically keep the MCU hardware interface waiting until the internal buffer is available for MCU to fill 64 bytes of data.

### **Block Move**

The MCU can move the bitmap from one area to another in the bitmap buffer by following the procedure below.

Check whether there is a previously unfinished burst command by checking the OSG\_OP\_START register (0x64F). If it is "1", then the MCU will wait until it is cleared, i.e., previous command finished.

Set the OSG\_OPMODE (0x642) to 1, which mean the bitmap block move mode.

Set the source location by setting the OSG\_SRC\_SH / OSG\_SRC\_SV in 0x645 ~ 0x647.

Set the destination block move area by setting OSG\_DST\_SV / OST\_DST\_SH (0x64B ~ 0x64D) for the upper left corner, and OSG\_DST\_EV / OSG\_DST\_EH (0x648 ~ 0x64A) for the right lower corner.

Set the OSG\_OP\_START to "1" to start a block move. When the block move finishes, the OSG\_OP\_START bit is self cleared to "0".

### **Block Fill**

The MCU can update a rectangular area of a single color by doing the following procedure.

Check whether there is a previously unfinished burst command by checking the OSG\_OP\_START register (0x64F). If it is "1", then the MCU will wait until it is cleared, i.e., previous command finished.

Set the OSG\_OPMODE (0x642) to 2, which mean the bitmap burst fill mode.

Set the destination block move area by setting OSG\_DST\_SV / OST\_DST\_SH (0x64B ~ 0x64D) for the upper left corner, and OSG\_DST\_EV / OSG\_DST\_EH (0x648 ~ 0x64A) for the right lower corner.

Set the color of the pixel in OSG\_FILL\_COLR (0x654 ~ 0x657). This is a 2-pixel data due to the use of 422 format in bitmap buffer.

Set the OSG\_OP\_START to "1" to start a block fill. When the block fill finishes, the OSG\_OP\_START bit is self cleared to "0"

### **Color Conversion**

TW2851 can convert a specific pixel data to another one during the bitmap fill, block move, block fill, and upscaling operation. A color conversion table can be configured to specify 4 sets of source pixel data value and destination pixel data value. Whenever a pixel data matches an entry in the color conversion table, its pixel value is converted to the output pixel data before writing into the bitmap buffer. In order to do this, simply turn on the color conversion by setting OSG\_COLR\_CON (0x642) to "1" before issuing the OSG\_OP\_START in each of the operation.

TW2851 uses an indirect read/write mechanism to access internal color table. To access the color conversion table,

Set the indirect target OSG\_SELOSG (0x64E) to 0 to choose color conversion table

Set the OSG\_IND\_ADDR (0x650) to the entry index to be accessed

Write the OSG\_IND\_WRDATA with the target data.

Issue OSG\_INDRD / OSG\_INDWR to read / write an entry. These bits are self-cleared after done. The address will be auto-incremented. To continue write more entries, simply repeat step (2) to (5).

The color conversion table has 4 entries of 8 bytes each. For the nth entry, (n = 0 ~ 3), the table address and content is as follows

Byte 8*n + 0	input U
Byte 8*n + 1	input Y1
Byte 8*n + 2	input V
Byte 8*n + 3	input Y2
Byte 8*n + 4	output U
Byte 8*n + 5	output Y1
Byte 8*n + 6	output V
Byte 8*n + 7	output Y2

### **Bitmap Windows**

The TW2851 OSG can display the content from any location/size in the bitmap buffer to any location on the output video stream. The TW2851 supports two layers of bitmap OSG. One layer supports a single window up to full screen size. Another layer supports 8 smaller non-overlapping windows. Each layer can be turned on/off through register OSD\_WINMAIN\_ON and OSD\_WINSUB\_ON register in 0xm34. The bitmap pixel format of YUV or RGB is also controlled in this register.

Each of the 9 windows can be further configured separately by first selecting the window number with OSD\_WINSEL in 0xm31. The OSD\_WINSEL 0 ~ 7 are for the 8 windows of the multi-window layer, and 8 is the window for the single window layer. Through this selection, the configuration changes are done by first writing the configuration data in 0xm37 ~ 0xm3F, OSD\_BLINK\_EN (0xm30), and OSD\_WIN\_EN (0xm35), and then issue a write command by setting OSD\_WINSET bit to 1 in 0xm35. Through this, the configuration data of each window is stored internally.

The setting of each window allows the bitmap layer controller to read an area of bitmap data from the external DDR SDRAM, and display at a specified destination location on the screen. To do this, the source OSG location is specified by OSD\_SRC\_SV and OSD\_SRC\_SH (0xm37 ~ 0xm39). There is a limitation on the OSD\_SRC\_SH that it has to be at the 64 pixel boundary in order to display the OSG window correctly.

The destination area is specified by the upper left corner (OSD\_DST\_SV, OSD\_DST\_SH) and the lower right corner (OSD\_DST\_EV, OSD\_DST\_EH) in register 0xm3A ~ 0xm3F, and also enable the window by setting the enable bit OSD\_WIN\_EN (0xm35) to 1. Note that the implementation of TW2851 does not allow the 8 windows in the multi-window layer to overlap each other on the destination screen.

In addition to simply block read from the DDR SDRAM, each window also has the following features.

### **Transparent Blending**

Each layer has its own transparent blending alpha so that the video / layer 1 and layer 2 can all be blended together. The single window layer is control by OSD\_GLOBAL\_ALPHA1 (0xm32). The 8 windows in the 8-window layer share another one OSD\_GLOBAL\_ALPHA2 (0xm33). The priority of the two layers can be swapped, i.e., single window layer can be on top or bottom of the multi-window layer, by using the OSD\_BLEND\_OPT at 0xm34.

### **Blinking**

The 9 windows support the blinking feature independently. This is done by setting the OSD\_BLINK\_EN (0xm30), and the bitmap will blink by switching on and off the bitmap window using a timer set by OSD\_BLINK\_TIME (0xm35).

## Dynamic Field Switching

The recording path OSG features a dynamic field switching feature that allows the OSG windows be controlled to turn on and off from field to field through the record switch queue entries. This mode is turned on by setting OSD\_WINSWITCH to 1. When this is set, the window enable signal is controlled by the record switch queue entry. Bit 23 ~ 27 controls the lower 4 windows of OSG for record port 0, and bit 28 ~ bit 31 controls the lower 4 windows in the OSG of record port 1. When the switch queue entry changes from field to field, the OSG windows enabled also changed. This allows an OSG window to lock on a particular channel in the field interleaving case, and put on channel specific information. The upper 4 windows of the recording path OSG are not affected by this setting.

## SINGLE BOX

The TW2851 provides 8 single boxes that can be used for picture masking or drop down menu. The 8 single boxes are separated into two layers. The first 2 windows are above the bitmap OSG layer, while the other 6 windows are below the bitmap OSG layer. Each of the layer can be turned on / off through the BOX1D\_EN[1:0] in 0xm67. Each layer can be programmed to blend transparently through BOX1D\_ALPHA0 and BOX1D\_ALPHA1 in 0xm64. Usually the single box is single color. When used as a picture privacy masking box, however, the single box can be programmed to show mosaic blocks using two different colors. The two colors are programmed through MOSAIC\_COLOR\_SEL0 and MOSAIC\_COLOR\_SEL1 at 0xm66.

Similar to the bitmap and 2D box layer, the 8 single boxes are programmed through indirect write by using the MDCH\_SEL in 0xm76. The configuration register is applied to a specific 1D box if the corresponding bit in MDCH\_SEL is set to 1. For example, by setting MDCH\_SEL[0] to 1, a write to MOSAIC\_EN at 0xm68 will turn on the MOSAIC\_EN bit for the first 1D box. If MDCH\_SEL is 0xFF, then a write to MOSAIC\_EN at 0xm67 will be turn on the mosaic in all 2D boxes simultaneously.

The single box has configuration registers in register 0xm68 ~ 0xm6F. The BOX1D\_HL is the horizontal location of box with 2-pixel unit and the BOX1D\_HW is the horizontal size of box with 2-pixel unit. The BOX1D\_VT is the vertical location of box with 1 line unit and the BOX1D\_VW is the vertical size of box with 1 line unit. The BOX1D\_BDR\_EN and BOX1D\_INT\_EN (0xm68) registers turn on the border and interior display of the 1D Box using the colors defined by BOX1D\_COLR and BOX1D\_BDR\_COLR in 0xm69. The BOX1D\_COLR register selects one out of 12 fixed colors or 4 user defined colors specified with the CLUT (0xm78 ~ 0xm83). The BOX1D\_BDR\_COLR selects one out of the 4 gray level colors.

In case that several boxes have same region, there will be a conflict of what to display for that region. Generally the TW2851 defines that box 0 has priority over box 3. So if a conflict happens between more than 2 boxes, box 0 will be displayed first as top layer and box 1 to box 3 are hidden beneath.

## MOUSE POINTER

The TW2851 supports the mouse pointers on all the 5 OSGs for display, record, and SPOT. However, only one of them should be turned on at a time. This is through the CUR\_EN in 0x65B. The mouse cursor supports features such as reverse color, blinking, hollow shape, different size, or even custom cursor shape, all through register 0x65C. The location of the cursor is at CUR\_X, CUR\_Y at 0x65D ~ 0x65F.

TW2851 supports customized cursor. The user can upload as many different cursor bitmaps as possible into the external DDR memory through the DDR burst write through the host interface. Please refer to the Host Interface section on page 87. The memory space used can be any area in the bitmap buffer, even though it is not actually used by the bitmap OSG layer. The custom cursor is a bitmap of 48 x 48 pixels, with each pixel represented in 2 bits. There will be total of 576 bytes of data for one customized cursor. The pixel arrangement in the 576 bytes is big endian in rasterscan format. I.e., the first pixel is the bit [7:6] of byte 0, second pixel is the bit [5:4] of byte 0, etc.,etc. The pixel data coding is as follows:

- 0      Transparent
- 1      border pixel (always black)
- 2      white pixel for interior

**3      black pixels for interior**

Once all the cursors are uploaded in the DDR SDRAM, they can be read back on the fly into an on-chip cursor RAM for use whenever needed. This is also done through the AUX interface.

- (1) Enable the CUR\_CUSTOM\_LD bit to '1'
- (2) Read the cursor content by setting the DDR AUX interface with size of 576 bytes. (Refer to the Host Interface section on page 87.) The content will be burst read from the DDR to On-Chip cursor SRAM. Note that with the setting of CUR\_CUSTOM\_LD in (1), the host burst interface automatically read back the whole cursor bitmap continuously without CPU intervention. The MCU does not need to read burst data like normal AUX read.
- (3) Turn off the CUR\_CUSTOM\_LD by setting to '0'
- (4) Set the CUR\_SEL in 0x65C to 2 to use this custom cursor.

## Audio Codec

The audio codec in the TW2851 is composed of five audio Analog-to-Digital converters, 1 Digital-to-Analog converter, audio mixer, digital serial audio interface and audio detector shown as the Figure 33. The TW2851 can accept 5 analog audio signals and 1 digital serial audio data and produce 1 mixing analog audio signal and 2 digital serial audio data.

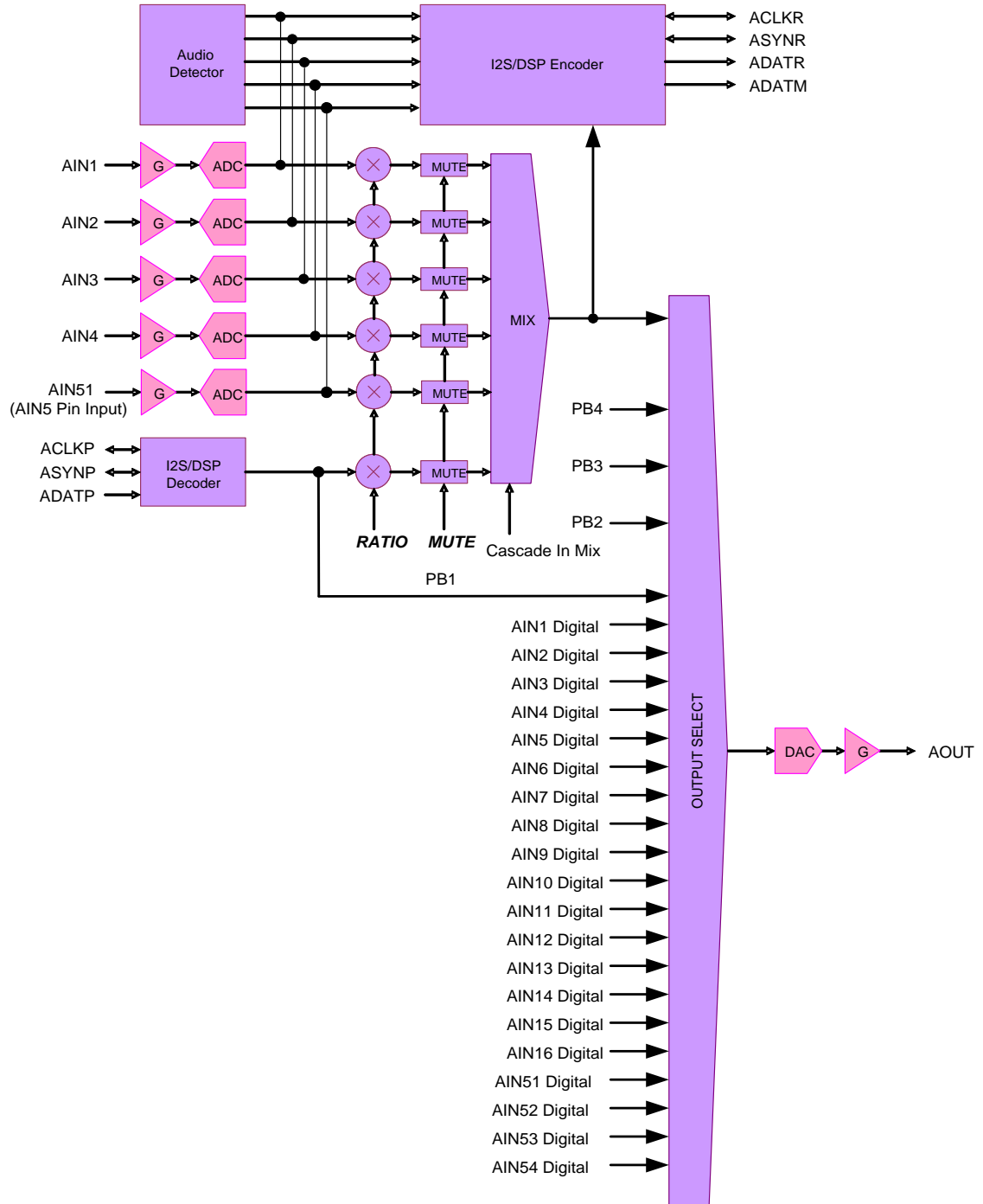
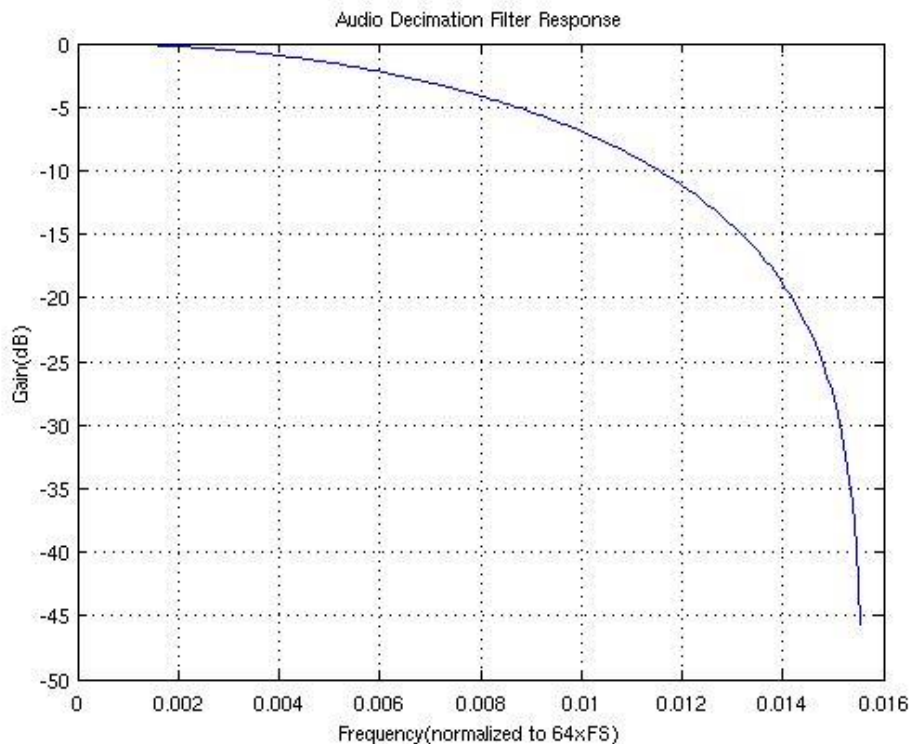

FIGURE 33. BLOCK DIAGRAM OF AUDIO CODEC

The level of analog audio input signal AIN1 ~ AIN5 can be adjusted respectively by internal programmable gain amplifiers that are defined via the AIGAIN1, AIGAIN2, AIGAIN3, AIGAIN4, and AIGAIN5 registers and then sampled by each Analog-to-Digital converters. Figure 34 shows the audio decimation filter response. The digital serial audio input data through the ACLKP, ASYNP and ADATP pin are used for playback function. To record audio data, the TW2851 provides the digital serial audio output via the ACLKR, ASYNR and ADATR pin.

The TW2851 can mix all of audio inputs including analog audio signal and digital audio data according to the predefined mixing ratio for each audio via the MIX\_RATIO1 ~ MIX\_RATIO5 and MIX\_RATIO6 registers. This mixing audio output can be provided through the analog and digital interfaces. The ADATM pin supports the digital mixing audio output and its digital serial audio timings are provided through the ACLKR and ASYNR pins that are shared with the digital serial audio record timing pins.



(\* ) 0.016 line = 0.016x64xFS

FIGURE 34. AUDIO DECIMATION FILTER RESPONSE

## AUDIO CLOCK MASTER/SLAVE MODE

The TW2851 has two types of Audio Clock modes. If ACLKRMAS<sub>TER</sub> register is set to 1, the audio sample rate 256xfs is processed from an internal audio clock generator ACKG. In this master mode, ACLKR/ASYNR pins are output mode. ASYNROEN register for ASYNR pin should be set to 0 (output enable mode). If ACLKRMAS<sub>TER</sub> register is set to 0, audio sample rate is processed from external audio clock through the ACLKR pin input. A 256xfs, 320xfs, or 384xfs external audio clock should be connected to ACLKR pin from external master clock source in this slave mode. ASYNR pin can be input or output by external Audio clock master in slave mode. ASYNR signal should change per fs audio sample rate in both master and slave mode. AIN5MD and AFS384 register setup audio fs mode with the following table.

REGISTER		FS MODE
AIN5MD	AFS384	
0	0	256xfs
1	0	320xfs
0	1	384xfs

## AUDIO DETECTION

The TW2851 has an audio detector for each individual of 5 channels. There are 2 kinds of audio detection method defined by the ADET\_MTH. One is the detection of absolute amplitude and the other is of differential amplitude. For both detection methods, the accumulating period is defined by the ADET\_FILT register and the detecting threshold value is defined by ADET\_TH1 ~ ADET\_TH5 registers. The status for audio detection is read by the STATE\_AVDET register and it also makes the interrupt request through the IRQ pin with the combination of the status for video loss detection.

## AUDIO MULTI-CHIP CASCADE

TW2851 can output 16 channel audio data on ACLKR/ASYNR/ADATR output simultaneously. Therefore, up to 4 chips can be connected on most Multi-Chip application cases. ALINKI pin is the audio cascade serial input, and ALINKO pin is the audio cascade serial output.

Each stage chip can accept 5 analog audio signals so that four cascaded chips will be 16-channel audio controller as default AIN5MD=0. The first stage chip provides 16ch digital serial audio data for record. Even though the first stage chip has only 1 digital serial audio data pin ADATR for record, the TW2851 can generate 16 channel data simultaneously using multi-channel format. Also, each stage chip can support 4 channel record outputs that are corresponding with analog audio inputs. This first stage chip can also output 16 channels mixing audio data by the digital serial audio data and analog audio signal. The last stage chip accepts the digital serial audio data for playback. The digital playback data can be converted to analog signal by Digital-to-Analog Converter in the last stage chip.

In Multi-Chip Audio operation mode, one same Oscillator clock source (27 MHz) needs to be connected to all TW2851 XTI or TW2851 CLKI pins.

Several Master/Slave mode configurations are available. The Figure 35 shows the most recommended and demanded system with Clock Master mode (ACLKRMAS<sub>TER</sub>=1). Figure 36 is the most recommended system with Clock Slave Sync Slave mode (ACLKRMAS<sub>TER</sub>=0, ASYNCR\_OEN=1). Other system combinations are also possible if the application needs. The two cascade modes shown are typical systems.

In each of the following figures, Mix1-16-51-54/Pb1 means Mix output of AIN1-16, AIN51-AIN54, and Playback1. AIN1-16-51-54/Pb1 means one selected Audio output in AIN1-16-51-54/Pb1.

If one TW2851 uses AIN5MD=1, all other cascaded TW2851 chips must set up AIN5MD=1 also. Generally, 4 audio input mode (AIN5MD=0) are most used in this cascade system.

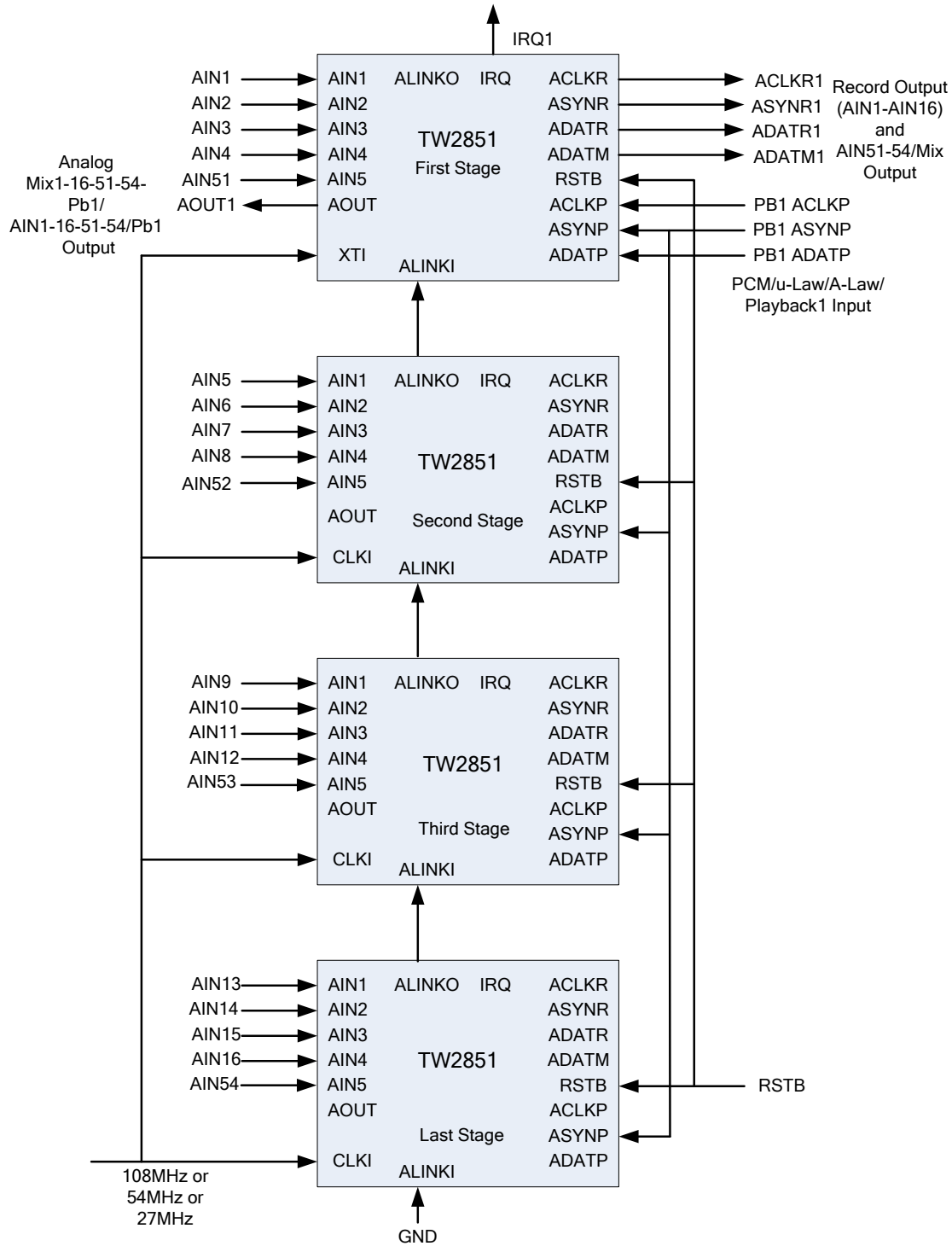

FIGURE 35. RECOMMENDED CLOCK MASTER CASCADE MODE SYSTEM WITH ACLKRMAS<sub>TE</sub>R = 1; ASYNROEN = 0; PB\_MASTER=0



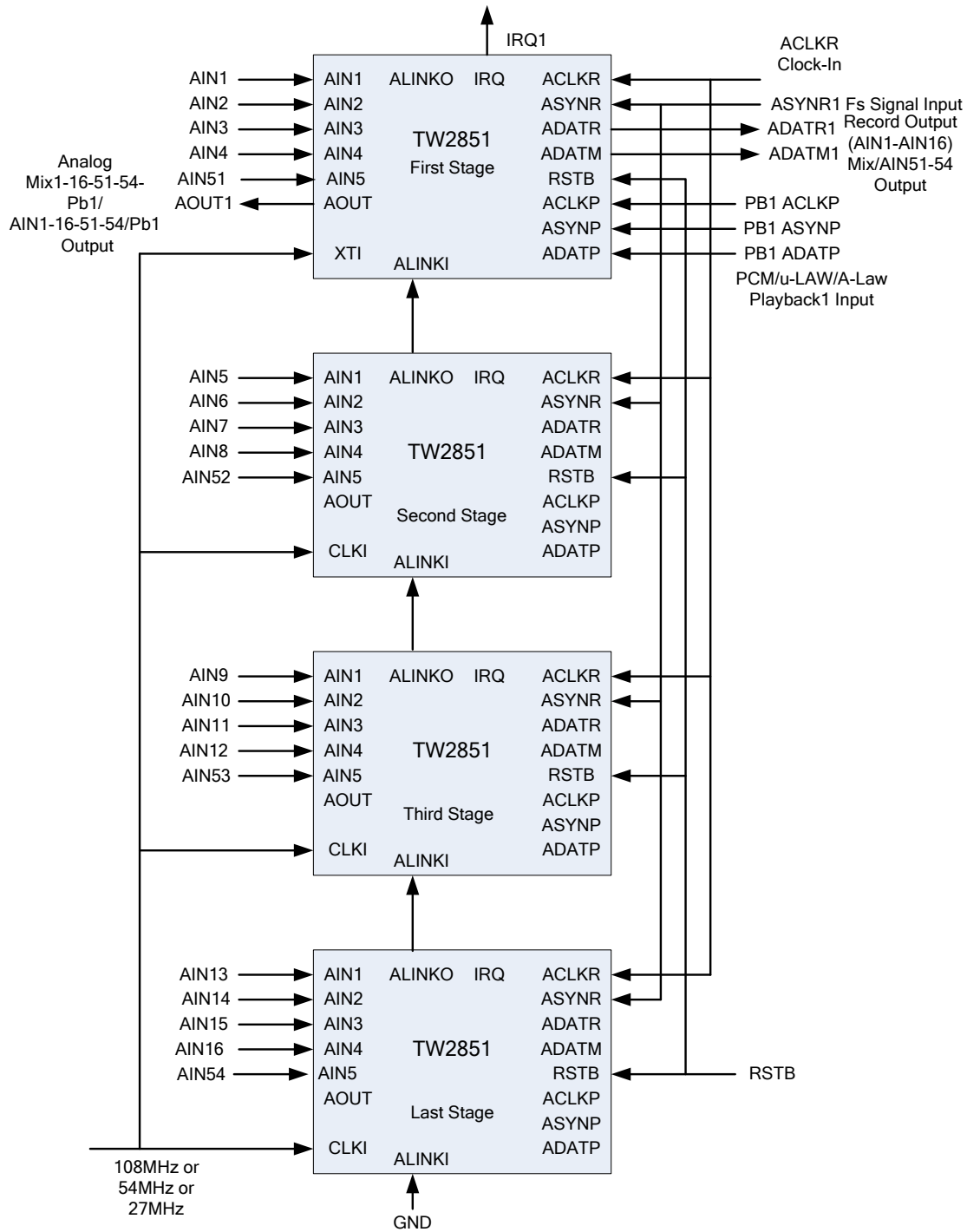

FIGURE 36. RECOMMENDED CLOCK SLAVE SYNC SLAVE CASCADE MODE SYSTEM WITH ACLKRMASER=0; ASYNROEN=1; PB\_MASTER=0

## SERIAL AUDIO INTERFACE

There are 3 kinds of digital serial audio interfaces in the TW2851, the first is a recording output, the second is a mixing output and the third is a playback input. These 3 digital serial audio interfaces follow a standard I2S or DSP interface as shown in the Figure 37.

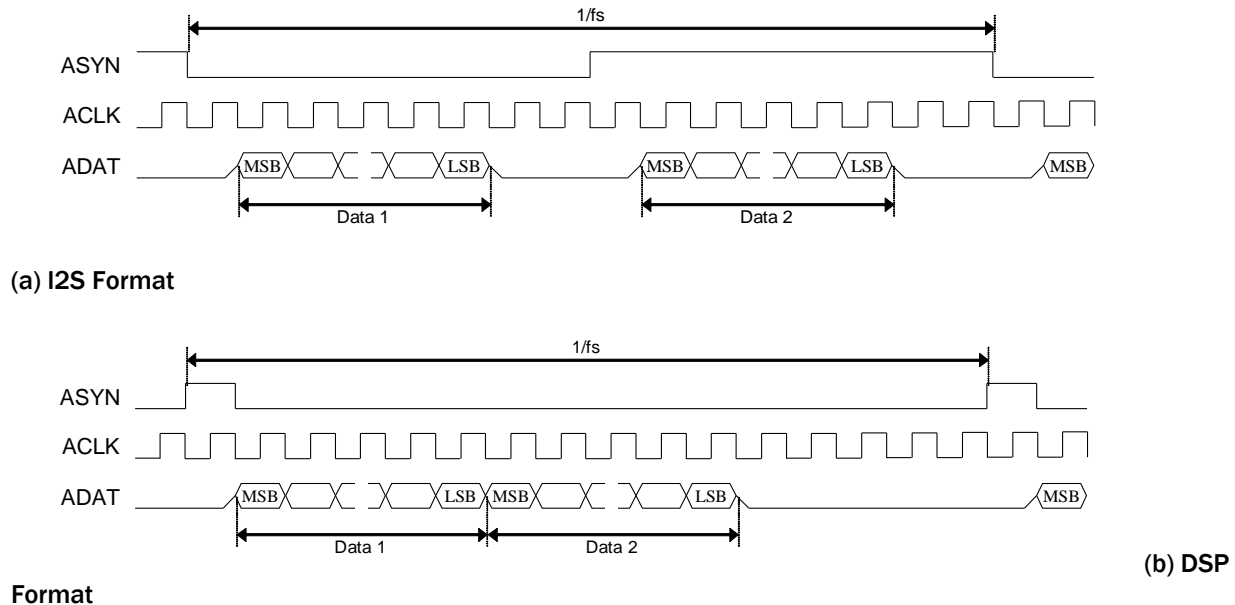

FIGURE 37. TIMING CHART OF SERIAL AUDIO INTERFACE

### Playback Input

The serial interface using the ACLKP, ASYNP and ADATP pins accepts the digital serial audio data for the playback purpose. The ACLKP and ASYNP pins can be operated as master or slave mode. For master mode, these pins work as output pin and generate the standard audio clock and synchronizing signal. For slave mode, these pins are input mode and accept the standard audio clock and synchronizing signal. The ADATP pin is always input mode regardless of operating mode. One of audio data in left or right channel should be selected for playback audio by the PB\_LRSEL.

**Record Output**

To record audio data, the TW2851 provides the digital serial audio data through the ACLKR, ASYNR and ADATR pins. Sampling frequency comes from 256xfs, 320xfs, or 384xfs audio system clock setting. Even though the standard I2S and DSP format can have only 2 audio data on left and right channel, the TW2851 can provide an extended I2S and DSP format which can have 16-channel audio data through ADATR pin. The R\_MULTCH defines the number of audio data to be recorded by the ADATR pin. ASYNR signal is always fs frequency rate. One ASYNR period is always equal to 256xACLKR clock length with AIN5MD=0. Figure 38 shows the digital serial audio data organization for multi-channel audio.

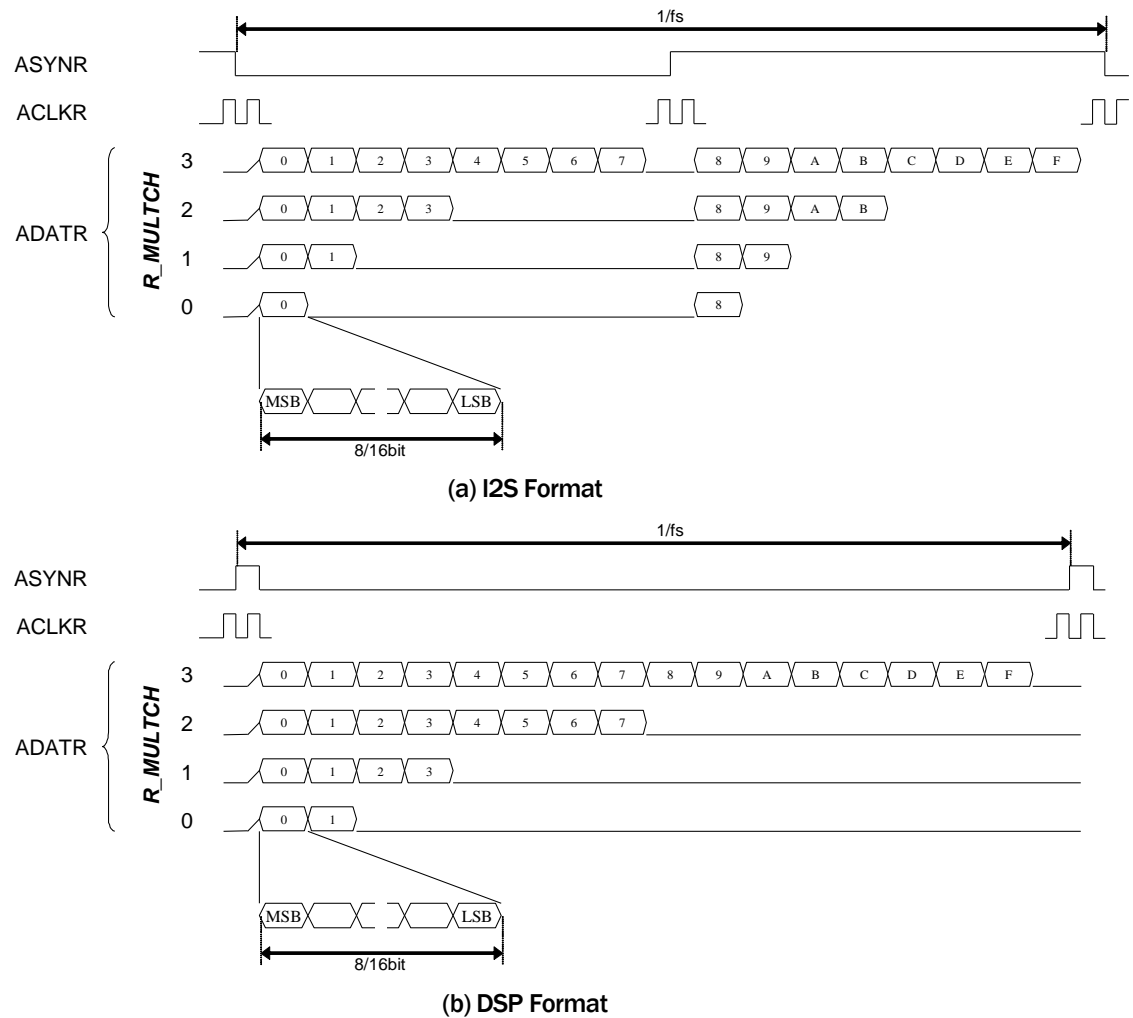

**FIGURE 38. TIMING CHART OF MULTI-CHANNEL AUDIO RECORD**

The following table shows the sequence of audio data to be recorded for each mode of the R\_MULTCH register. The sequences of 0 ~ F do not mean actual audio channel number but represent sequence only. The actual audio channel should be assigned to sequence 0 ~ F by the R\_SEQ\_0 ~ R\_SEQ\_F register. When the ADATM pin is used for record via the R\_ADATM register, the audio sequence of ADATM is showed also in Table 15.

**TABLE 15. SEQUENCE OF MULTI-CHANNEL AUDIO RECORD  
(A) I2S FORMAT**

R_MULTCH	Pin	Left Channel								Right Channel							
0	ADATR	0								8							
	ADATM	F								7							
1	ADATR	0	1							8	9						
	ADATM	F	E							7	6						
2	ADATR	0	1	2	3					8	9	A	B				
	ADATM	F	E	D	C					7	6	5	4				
3	ADATR	0	1	2	3	4	5	6	7	8	9	A	B	C	D	E	F
	ADATM	F	E	D	C	B	A	9	8	7	6	5	4	3	2	1	0

**(B) DSP FORMAT**

R_MULTCH	Pin	Left/Right Channel															
0	ADATR	0	1														
	ADATM	F	E														
1	ADATR	0	1	2	3												
	ADATM	F	E	D	C												
2	ADATR	0	1	2	3	4	5	6	7								
	ADATM	F	E	D	C	B	A	9	8								
3	ADATR	0	1	2	3	4	5	6	7	8	9	A	B	C	D	E	F
	ADATM	F	E	D	C	B	A	9	8	7	6	5	4	3	2	1	0

**Mix Output**

The digital serial audio data on the ADATM pin has 2 different audio data which are mixing audio and playback audio. The mixing digital serial audio data is the same as analog mixing output. The sampling frequency, bit width and number of audio for the ADATM pin are same as the ADATR pin because the ACLKR and ASYNR pins are shared with the ADATR and ADATM pins.

## AUDIO CLOCK SLAVE MODE DATA OUTPUT TIMING

TW2851 always output ASYNR/ADATR/ADATM by ACLKR falling edge triggered timing. ADATR/ADATM output data are always changing at the next ACLKR falling edge triggered timing after ASYNR signal changes. If ASYNR is output, ADATR/ADATM outputs are always fixed to one ACLKR falling edge timing. But if ASYNR is input, ADATR/ADATM output timing changes by ASYNR input timing.

### ASYNR is ACLKR Falling Edge Triggered Input/output

If ASYNR is input and ASYNR input is ACLKR falling edge triggered input as ASYNR input signal is changing after ACLKR falling edge, or if ASYNR is output, TW2851 output ADATR/ADATM by ACLKR falling edge triggered timing as shown on following figures. ASYNR signal is changing during ACLKR = 0. TW2851 output ADATR/ADATM data after next ACLKR falling edge triggered timing with more than half ACLKR clock delay.

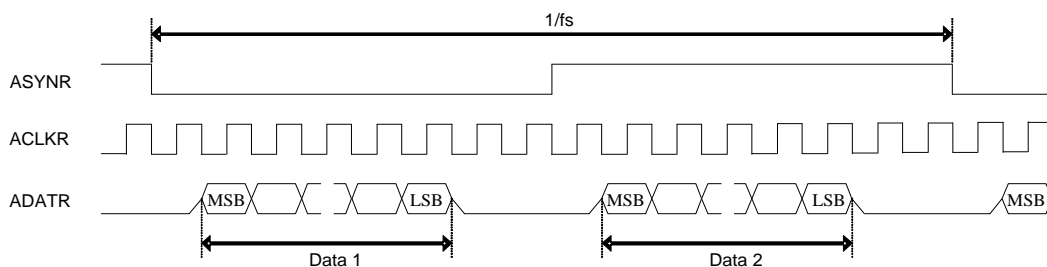

FIGURE 39. AUDIO RECORD FALLING EDGE TRIGGERED INPUT/OUTPUT TIMING, ACLKMASTER=0, RM\_SYNC=0

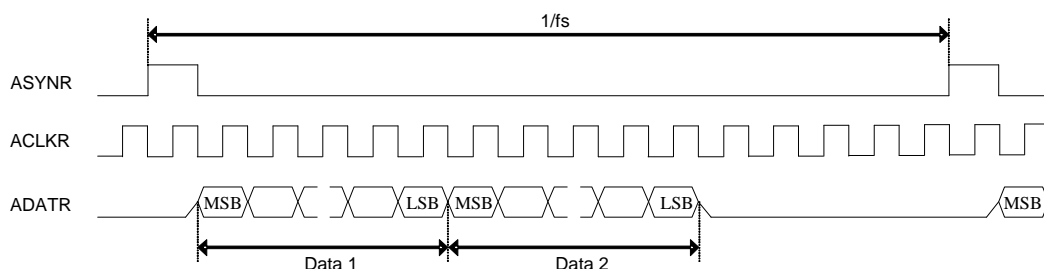

FIGURE 40. AUDIO RECORD FALLING EDGE TRIGGERED INPUT/OUTPUT TIMING, ACLKMASTER=0, RM\_SYNC=1

### ASYNR is ACLKR Rising Edge Triggered Input

If ASYNR is input and ASYNR input is ACLKR rising edge triggered input as ASYNR input signal is changing after ACLKR rising edge, TW2851 output ADATR/ADATM by ACLKR falling edge triggered timing as shown on following figures. ASYNR signal is changing during ACLKR = 1. TW2851 output ADATR/ADATM data after next ACLKR falling edge triggered timing with less than half ACLKR clock delay.

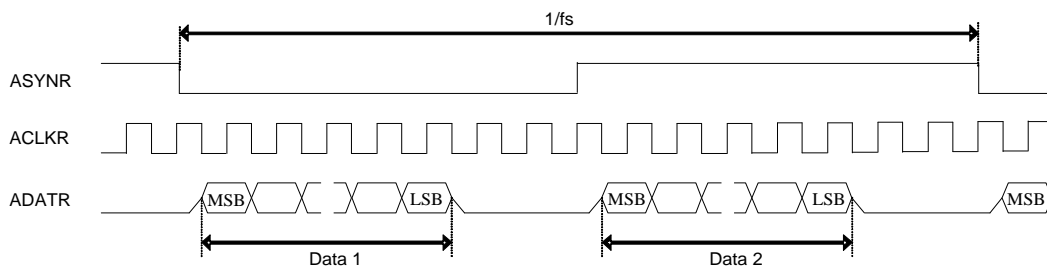

FIGURE 41. AUDIO RECORD RISING EDGE TRIGGERED INPUT TIMING, ACLKMASTER=0, RM\_SYNC=0, ASTBROEN=1

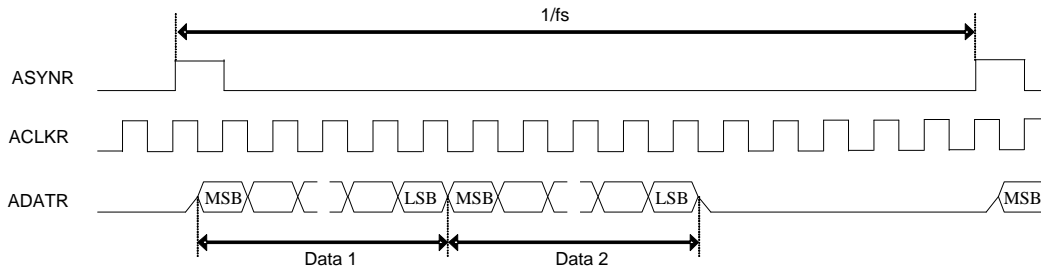

FIGURE 42. AUDIO RECORD RISING EDGE TRIGGERED INPUT TIMING, ACLKMASTER=0, RM\_SYNC=1, ASTBROEN=1

### ACLKP/ASYNP SLAVE MODE DATA OUTPUT TIMING

The following 8 data input timing figures are supported. The ADATPDLY register needs to be set up according to the difference of ADATP data input timings. Data1 is only used as default. MSB bit is the first input bit as default PBINSWAP=0. If PBINSWAP=1, LSB bit is the first input bit.

#### ASYNP is ACLKP Falling Edge Triggered Input

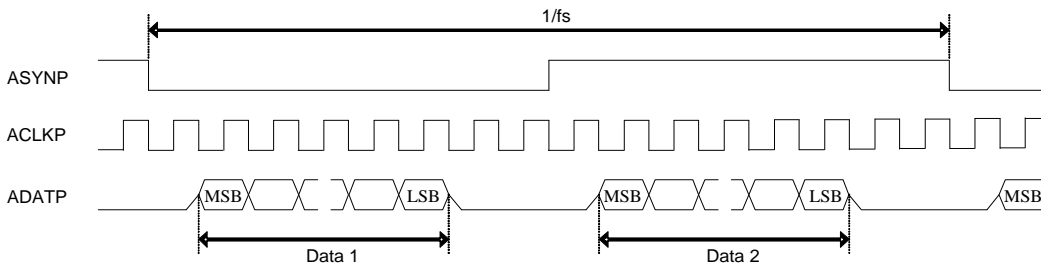

FIGURE 43. AUDIO PLAYBACK FALLING EDGE TRIGGERED INPUT TIMING, RM\_SYNC=0, PB\_MASTER=0, ADATPDLY=0

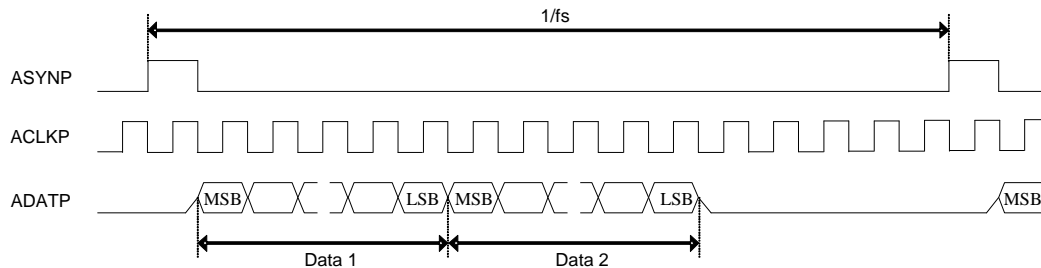

FIGURE 44. AUDIO PLAYBACK FALLING EDGE TRIGGERED INPUT TIMING, RM\_SYNC=1, PB\_MASTER=0, ADATPDLY=0

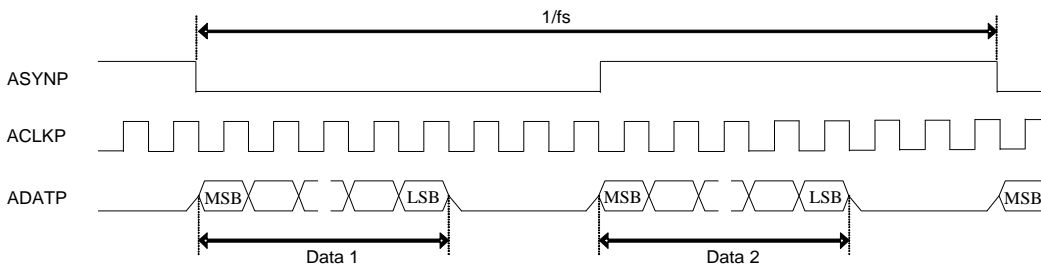

FIGURE 45. AUDIO PLAYBACK FALLING EDGE TRIGGERED INPUT TIMING, RM\_SYNC=0, PB\_MASTER=0, ADATPDLY=1

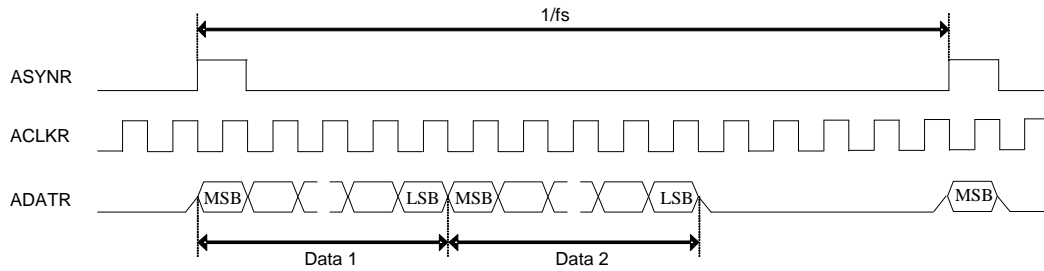

FIGURE 46. AUDIO PLAYBACK FALLING EDGE TRIGGERED INPUT TIMING, RM\_SYNC=1, PB\_MASTER=0, ADATPDLY=1

**ASYNP is ACLKP Rising Edge Triggered Input**

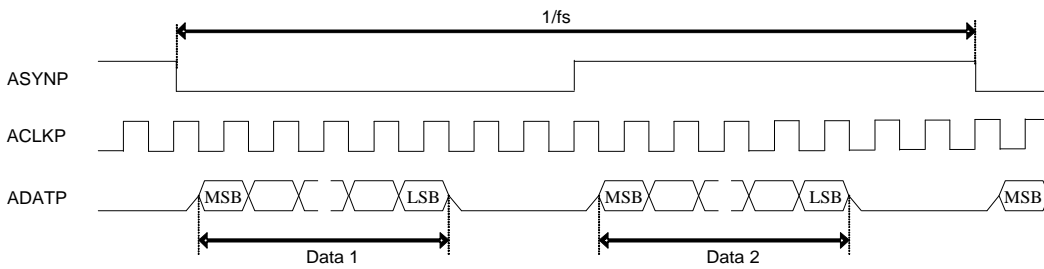

FIGURE 47. AUDIO PLAYBACK RISING EDGE TRIGGERED INPUT TIMING, RM\_SYNC=0, PB\_MASTER=0, ADATPDLY=1

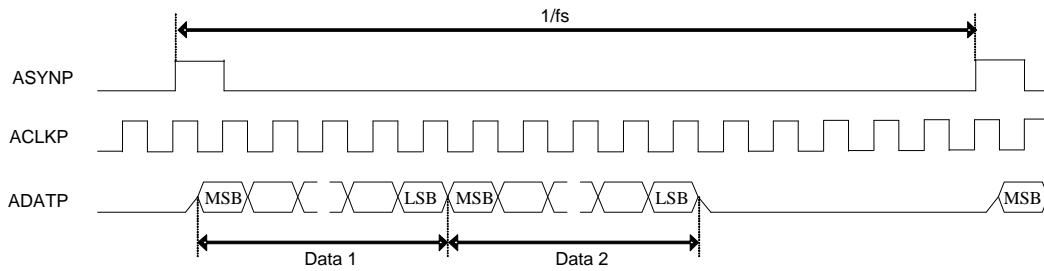

FIGURE 48. AUDIO PLAYBACK RISING EDGE TRIGGERED INPUT TIMING, RM\_SYNC=1, PB\_MASTER=0, ADATPDLY=1

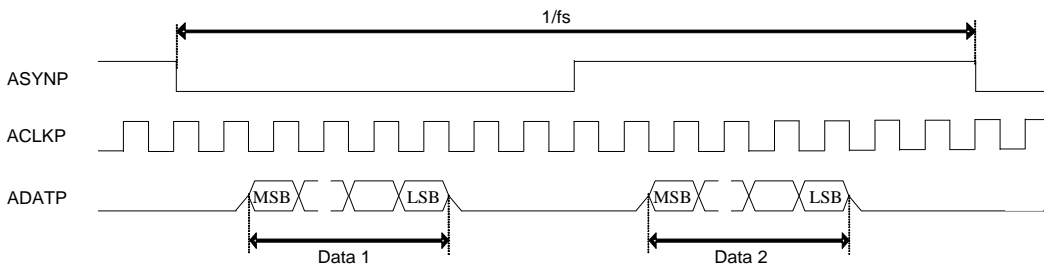

FIGURE 49. AUDIO PLAYBACK RISING EDGE TRIGGERED INPUT TIMING, RM\_SYNC=0, PB\_MASTER=0, ADATPDLY=0

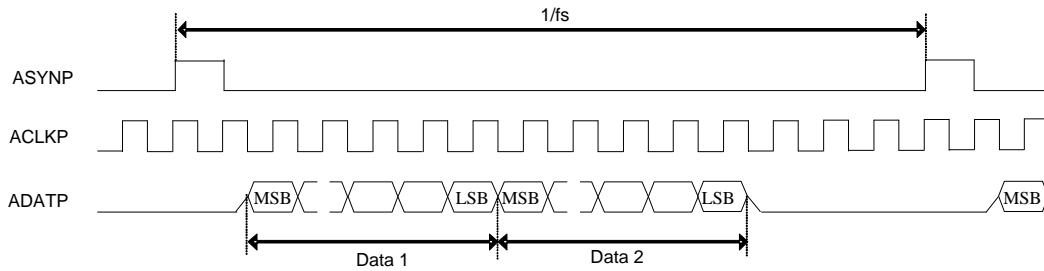

FIGURE 50. AUDIO PLAYBACK RISING EDGE TRIGGERED INPUT TIMING, RM\_SYNC=1, PB\_MASTER=0, ADATPDLY=0

## AUDIO CLOCK GENERATION

TW2851 has built-in field locked audio clock generator for use in video capture applications. The circuitry will generate the same predefined number of audio sample clocks per field to ensure synchronous playback of video and audio after digital recording or compression. The audio clock is digitally synthesized from the crystal clock input. The master audio clock frequency is programmable through ACKN and ACKI register based following two equations.

$ACKN = \text{round}( F_{AMCLK} / F_{field} )$ , it gives the Audio master Clock Per Field.

$ACKI = \text{round}( F_{AMCLK} / F_{27MHz} * 2^{23} )$ , it gives the Audio master Clock Nominal increment.

Following table provides setting example of some common used audio frequency assuming Video Decoder system clock frequency of 27MHz. If ACLKRMASER register bit is set to 1, following AMCLK is used as audio system clock inside TW2851.

If Slave Playback-in lock mode is required, ACKN=00100hex and PBREFEN=1 needs to be set up. The number of AMCLK clock per one ASYNP input cycle is locked(fixed) to 256 in this mode.

Frequency equation is " $AMCLK(\text{Freq}) = 256 \times ASYNP(\text{Freq})$ ".



TABLE 16. AUDIO FREQUENCY 256XFS MODE: AIN5MD = 0, AFS384 = 0

AMCLK(MHZ)	FIELD(HZ)	ACKN [DEC]	ACKN [HEX]	ACKI [DEC]	ACKI [HEX]
<b>256 X 48 kHz</b>					
12.288	50	245760	3-C0-00	3817749	3A-41-15
12.288	59.94	205005	3-20-CD	3817749	3A-41-15
<b>256 X 44.1 kHz</b>					
11.2896	50	225792	3-72-00	3507556	35-85-65
11.2896	59.94	188348	2-DF-BC	3507556	35-85-65
<b>256 X 32 kHz</b>					
8.192	50	163840	2-80-00	2545166	26-D6-0E
8.192	59.94	136670	2-15-DE	2545166	26-D6-0E
<b>256 X 16 kHz</b>					
4.096	50	81920	1-40-00	1272583	13-6B-07
4.096	59.94	68335	1-0A-EF	1272583	13-6B-07
<b>256 X 8 kHz</b>					
2.048	50	40960	A0-00	636291	9-B5-83
2.048	59.94	34168	85-78	636291	9-B5-83

TABLE 17. AUDIO FREQUENCY 320XFS MODE: AIN5MD = 1, AFS384 = 0, 44.1/48 KHZ NOT SUPPORTED

AMCLK(MHZ)	FIELD(HZ)	ACKN [DEC]	ACKN [HEX]	ACKI [DEC]	ACKI [HEX]
<b>320 X 32 kHz</b>					
10.24	50	204800	3-20-00	3181457	30-8B-91
10.24	59.94	170838	2-9B-56	3181457	30-8B-91
<b>320X16 kHz</b>					
5.12	50	102400	1-90-00	1590729	18-45-C9
5.12	59.94	85419	1-4D-AB	1590729	18-45-C9
<b>320 X 8 kHz</b>					
2.56	50	51200	C8-00	795364	C-22-E4
2.56	59.94	42709	A6-D5	795364	C-22-E4

TABLE 18. AUDIO FREQUENCY 384XFS MODE: AIN5MD = 0, AFS384 = 1, 44.1/48 KHZ NOT SUPPORTED

AMCLK(MHZ)	FIELD(HZ)	ACKN [DEC]	ACKN [HEX]	ACKI [DEC]	ACKI [HEX]
<b>384 X 32 kHz</b>					
12.288	50	245760	3-C0-00	3817749	3A-41-15
12.288	59.94	205005	3-20-CD	3817749	3A-41-15
<b>384X16 kHz</b>					
6.144	50	122880	1-E0-00	1908874	1D-20-8A
6.144	59.94	102503	1-90-67	1908874	1D-20-8A
<b>384 X 8 kHz</b>					
3.072	50	61440	F0-00	954437	E-90-45
3.072	59.94	51251	C8-33	954437	E-90-45

### AUDIO CLOCK AUTO SETUP

If ACLKRMAS<sub>TER</sub>=1 audio clock master mode is selected, and AFAUTO register is set to "1", TW2851 set up ACKI register by AFMD register value automatically. ACKI control input in ACKG module block is automatically set up to the required value by the condition of AIN5MD and AFS384 register value.

AFAUTO	AFMD	ACKG MODULE ACKI CONTROL INPUT VALUE
1	0	8kHz mode value by each AIN5MD/AFS384 case.
1	1	16kHz mode value by each AIN5MD/AFS384 case.
1	2	32kHz mode value by each AIN5MD/AFS384 case.
1	3	44.1kHz mode value by each AIN5MD/AFS384 case.
1	4	48kHz mode value by each AIN5MD/AFS384 case.
0	X	ACKI register set up ACKI control input value.

## Host Interface

The TW2851 provides both serial and parallel interfaces that can be selected by HSP[1:0] pins. When HSP = 01, the I2C serial interface is selected. Else the parallel host interface is selected. There are three different host interface mode: the address / data mux mode with ALE high active (HSP = 00), the address / data mux mode with ALE low active (HSP = 10), and the address data separate mode (HSP = 11).

Some of the interface pins serve a dual purpose depending on the working mode. The pins HALE and HDAT [7] in parallel mode become SCLK and SDAT pins in serial mode and the pins HDAT [6:1] and HCSB in parallel mode become slave address in serial mode respectively. See Table 19 for pin assignment details of each of the mode.

TABLE 19. PIN ASSIGNMENTS FOR SERIAL AND PARALLEL INTERFACE

PIN NAME	SERIAL MODE (HSP = 01)	A/D MUX WITH HIGH ACTIVE ALE (HSP = 00)	A/D MUX WITH LOW ACTIVE ALE (HSP = 10)	A / D SEPARATE (HSP = 11)
HALE	SCLK	ALE	ALE	Not Used
HRDB	Not Used (VSSO)	RENB	RENB	RENB
HWRB	Not Used (VSSO)	WENB	WENB	WENB
HCSB	Slave Address[0]	CSB	CSB	CSB
HDAT[0]	Not Used (VSSO)	PDATA [0] / PADDR[0]	PDATA[0] / PADDR[0]	PDATA[0]
HDAT[6:1]	Slave Address[6:1]	PDAT [6:1] / PADDR[6:1]	PDAT [6:1] / PADDR[6:1]	PDATA[6:1]
HDAT[7]	SDAT	PDATA[7] / PADDR[7]	PDATA[7] / PADDR[7]	PDATA[7]
HDAT[15:8]	Not Used	PDATA[15:8]	PDATA[15:8]	PDATA[15:8]
HADDR[7:0]	Not Used	Not Used	Not Used	PADDR[7:0]
HADDR[11:8]	Not Used	Not Used	Not Used	PADDR[11:8]

In serial interface mode and the A/D mux mode, the TW2851 has 8 bits of address. In order to access all the internal registers, an additional 4-bit address is used as page index. All the registers are organized into 16 page of 256 byte register each. The page index register is specified in a register at address 0xFF of each page. By setting the page index first, the following accesses are directed to the corresponding page. In cases of address / data separate mode, the page index is derived from PADDR[11:8]. The page index register at 0xFF is not used. For detailed description of registers, please refer to the

Register Description section on page 97.

In parallel bus case, the data bus width can be set to either 8-bit wide or 16-bit wide. This is controlled by a power up strapping of the status of VGA\_VS pin. If the VGA\_VS pin is pull-up with an external resistor, the parallel interface data bus is 16-bit wide. If it is pull-down, then the data bus is 8-bit. All registers on TW2851 runs with 8-bit mode data bus only, except the OSD bitmap upload data register (0x652). This register can be written 8-bit or 16-bit. Note that in some MCU running in 16-bit mode data bus, the addresses used to access the registers on TW2851 need to be left shifted by 1 bit.

## SERIAL INTERFACE

HDAT [6:1] and HCSB pins define slave address in serial mode. Therefore, any slave address can be assigned for full flexibility. The Figure 51 shows an illustration of serial interface for the case of slave address (Read : "0x085", Write : 0x084").

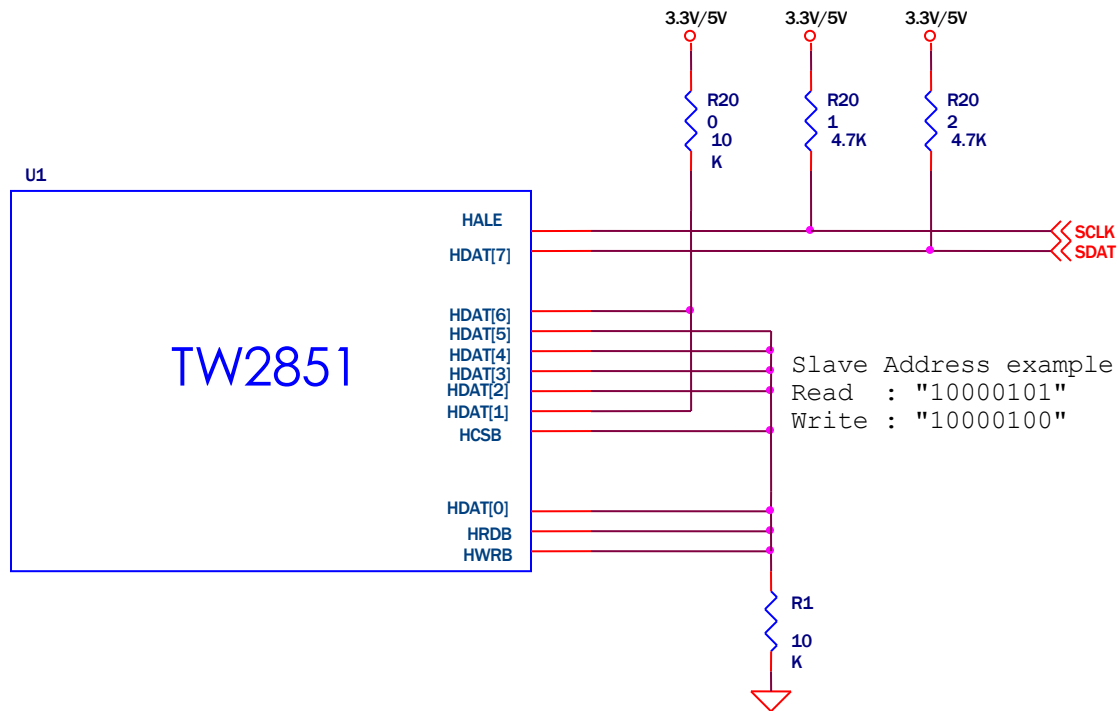

FIGURE 51. THE SERIAL INTERFACE FOR THE CASE OF SLAVE ADDRESS. (READ : "0X085", WRITE : "0X084")

The detailed timing diagram is illustrated in Figure 52 and Figure 53.

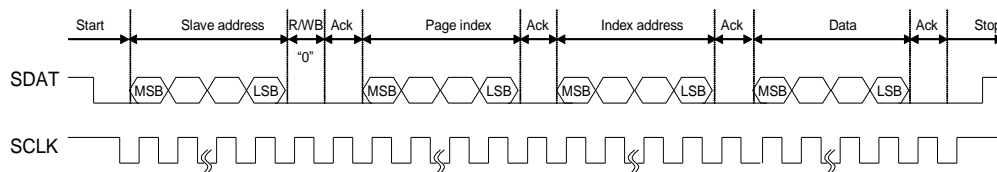

FIGURE 52. WRITE TIMING OF SERIAL INTERFACE

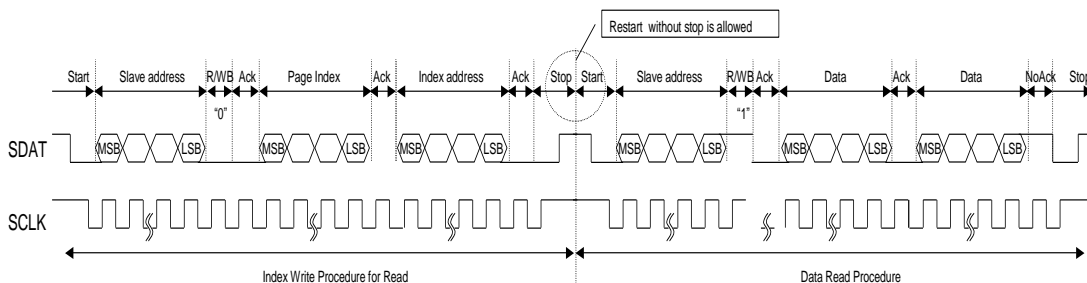

FIGURE 53. READ TIMING OF SERIAL INTERFACE

## PARALLEL INTERFACE

For A/D Muxed parallel interface mode (HSP = 00 or 10), the address and data are multiplexed to share the same bus pins. The writing and reading timing is shown in the Figure 54 and Figure 55 respectively. The detail timing parameters are in Table 20.

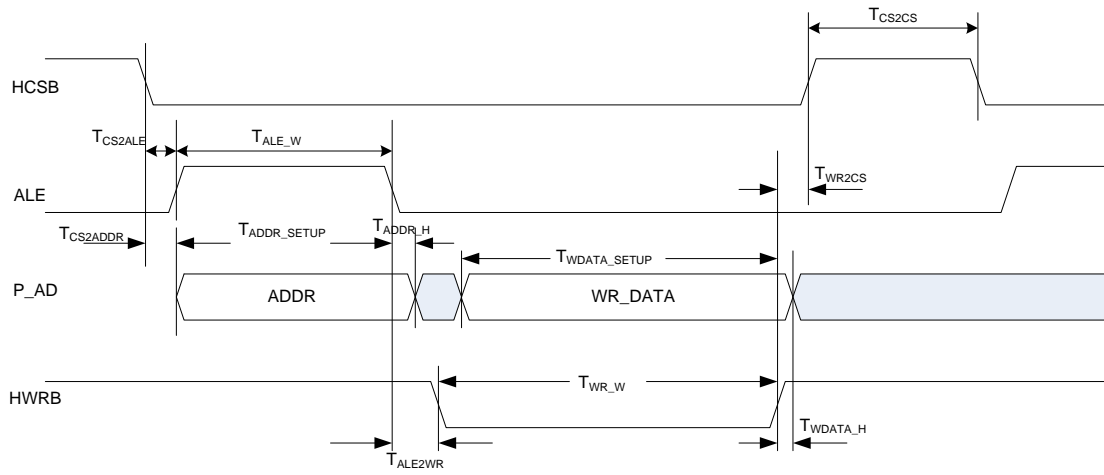

FIGURE 54. WRITE TIMING OF PARALLEL INTERFACE WITH ADDRESS/DATA MULTIPLEXING MODE

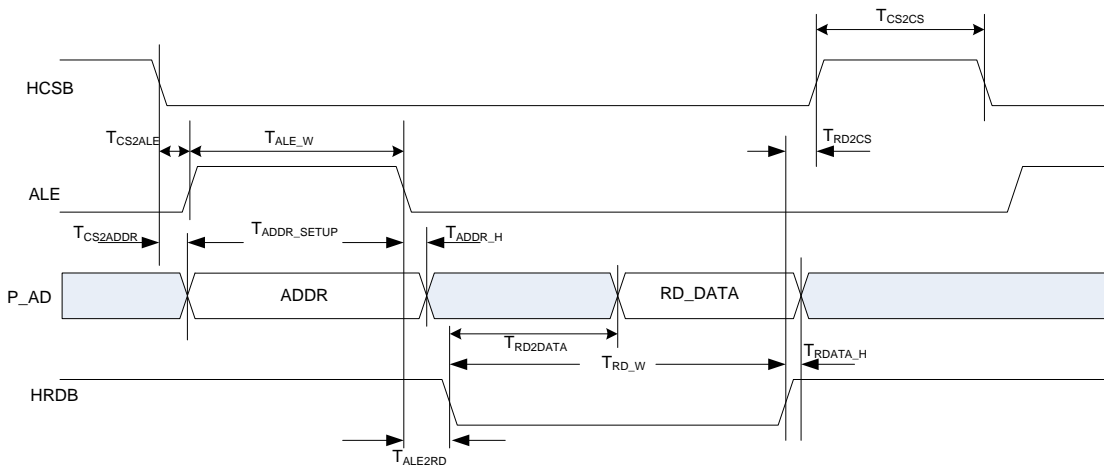

FIGURE 55. READ TIMING OF PARALLEL INTERFACE WITH ADDRESS / DATA MULTIPLEXING MODE

TABLE 20. TIMING PARAMETERS OF PARALLEL INTERFACE WITH ADDRESS / DATA MULTIPLEXING MODE

PARAMETER	SYMBOL	MIN	TYP	MAX	UNITS
HCSB Setup Until ALE Active	$T_{CS2ALE}$	> 0			ns
HCSB Setup Until ADDR Valid	$T_{CS2ADDR}$	> 0			ns
ALE Active Pulse Width	$T_{ALE\_W}$	1 CPU_CLK (Note 1)			ns
ADDR Valid Until Inactive of ALE	$T_{ADDR\_SETUP}$	10			ns
ADDR Hold After ALE Inactive	$T_{ADDR\_H}$	> 0			ns
ALE Inactive to HRDB Active	$T_{RD\_W}$	$T_{RD2DATA}$			ns
ALE Inactive to HWRB Active	$T_{WR\_W}$	1 CPU_CLK (Note 1)			ns
Read DATA Hold After HRDB Inactive	$T_{RDATA\_H}$	> 0			ns
Write Data Hold After HWRB Inactive	$T_{WDATA\_H}$	> 0			Ns
HRDB Active Till Valid Read DATA	$T_{RD2DATA}$			30	ns
Write DATA Setup Before HWRB Active	$T_{WDATA\_SETUP}$	10			
HRDB Inactive Before HCSB Inactive	$T_{RD2CS}$	> 0			
HWRB Inactive Before HCSB Inactive	$T_{WR2CS}$	1 CPU_CLK (Note 1)			
HCSB Inactive Before HCSB Active	$T_{CS2CS}$	1 CPU_CLK (Note 1)			ns

NOTE:

- The TW2851 internal CPU\_CLK is 54 MHz

For the mode with HSP = 11, the address and data bus are separate. The ALE signal is not used. The read / write timing of separate address/data bus is shown in Figure 56 and Figure 57.

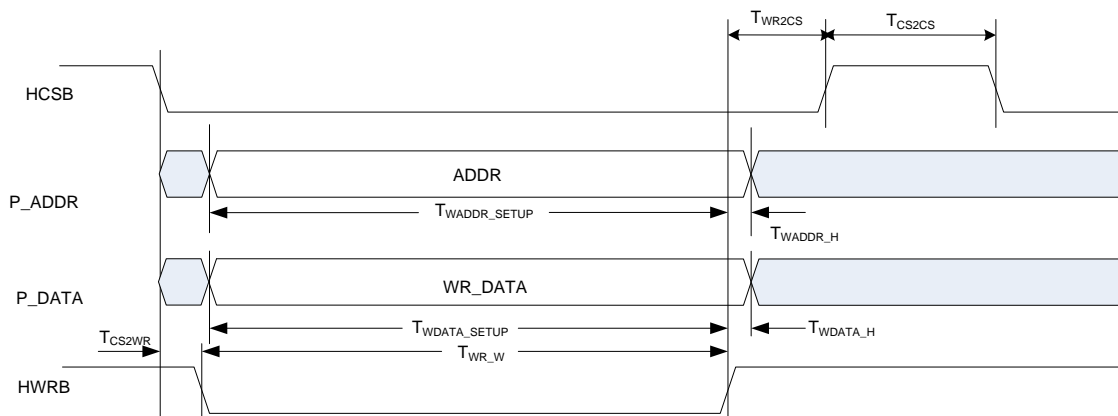

FIGURE 56. WRITE TIMING OF PARALLEL INTERFACE WITH SEPARATE ADDRESS / DATA BUS

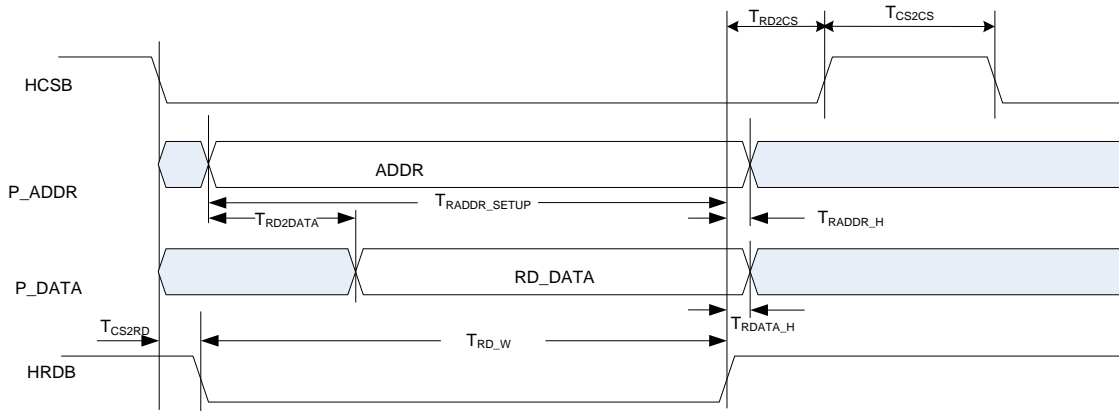

FIGURE 57. READ TIMING OF PARALLEL INTERFACE WITH SEPARATE ADDRESS / DATA BUS

TABLE 21. TIMING PARAMETERS OF PARALLEL INTERFACE WITH SEPARATE ADDRESS / DATA BUS

PARAMETER	SYMBOL	MIN	TYP	MAX	UNITS
HCSB Setup Until HWRB/HRDB Active	$T_{CS2RD}$ $T_{CS2WR}$	> 0			ns
Write ADDR Valid Until HWRB Inactive	$T_{WADDR\_SETUP}$	10			ns
Write ADDR Valid Until HRDB Inactive	$T_{RADDR\_SETUP}$	30			ns
Write ADDR Hold After HWRB inactive	$T_{WADDR\_H}$	> 0			ns
Read ADDR Hold After HRDB Inactive	$T_{RADDR\_H}$	> 0			ns
HRDB Active Pulse Width	$T_{RD\_W}$	$T_{RD2DATA}$			ns
HWRB Active Pulse Width	$T_{WR\_W}$	1 CPU_CLK (Note 1)			ns
Read DATA Hold After HRDB Inactive	$T_{RD\_DATA\_H}$	> 0			ns
Write DATA Hold After HWRB inactive	$T_{WDATA\_H}$	> 0			ns
Write DATA Setup Before HWRB Inactive	$T_{WDATA\_SETUP}$	10			ns
Read DATA Valid after ADDR Valid and HRDB Active	$T_{RD2DATA}$			1 CPU_CLK + 30 (Note 1)	ns
HRDB / HWRB Inactive Before HCSB Inactive	$T_{RD2CS}$ $T_{WR2CS}$	> 0			ns
HCSB Active After HCSB Inactive	$T_{CS2CS}$	1 CPU_CLK (Note 1)			ns

NOTE:

- The TW2851 internal CPU\_CLK is 54 MHz



## VGA DDC I2C MASTER INTERFACE

The TW2851 provides an I2C master interface as DDC channel for the VGA interface. It allows the CPU to read/write the DDC registers on the VGA monitors through this I2C interface. The DDC interface signals DDC\_CLK and DDC\_DATA needs to be externally pulled up on the board. The DDC channel control registers are at 0x9C0 ~ 0x9CF.

Before performing any of the I2C write/read operation, first program the DDC\_CLK frequency by setting the DDC\_FREQ\_DIV register (0x9C0 ~ 0x9C1). The DDC\_CLK frequency is derived from an internal 54 MHz clock divided by this parameter.

### Write Operation

To write an I2C device through this I2C master interface,

1. Set the I2C slave device address and write command in DDC\_WR\_DATA register (0x9C2)
2. Write command 0x96 into register 0x9C4 DDC\_COMMAND register. It will kick off the I2C Start operation, and output the slave device address onto the DDC\_DATA bus.
3. Wait for the ACK signal from I2C slave through the interrupt bit set in 0x9C4 DDC\_STATUS register.
4. Clear the interrupt by writing 0x0F into DDC\_COMMAND register (0x9C4)
5. Set the I2C slave register address in DDC\_WR\_DATA register (0x9C2)
6. Write command 0x16 to the DDC\_COMMAND register (0x9C4) to put the address into SDA bus
7. Wait for the ACK signal as in (4)
8. Clear the interrupt as in (5)
9. Write the data to be written to I2C slave register in DDC\_WR\_DATA register (0x9C2)
10. Write command 0x16 to the DDC\_COMMAND register (0x9C4) to put the data into SDA bus
11. Wait for ACK signal as in (4)
12. Clear the interrupt as in (5), and done with the I2C write operation

### Read Operation

To read a register in I2C device through this I2C interface,

1. Write the I2C slave device address and read command into DDR\_WR\_DATA register (0x9C2)
2. Write 0x96 to DDC\_COMMAND register to initiate the I2C Start operation, and put the slave device address onto DDC\_DATA bus
3. Wait for I2C slave ACK through the interrupt bit set in 0x9C4 DDC\_STATUS register.
4. Clear the interrupt by writing 0x0F into DDC\_COMMAND register (0x9C4)
5. Write the I2C slave register address into DDR\_WR\_DATA register (0x9C2)
6. Write 0x16 to DDC\_COMMAND register to put the slave register address to DDC\_DATA bus
7. Wait for I2C slave ACK as in (3)
8. Clear the interrupt as in (4)

9. Write 0x26 into DDC\_COMMAND register to urge the I2C slave to output the register data onto DDC\_DATA bus
10. Wait for the interrupt flag
11. Read the DDR\_RD\_DATA register 0x9C3 and finish the read operation

## PS2 MOUSE INTERFACE

The TW2851 provides a PS2 interface for mouse support. With this, the CPU can receive interrupts whenever the PS2 has events such as click, double click, cursor location change, etc. The PS2 interface signals PS2\_CK and PS2\_D should be pulled up on the board. The PS2 control registers are at register 0x9D0 ~ 0x9DF.

## INTERRUPT INTERFACE

The TW2851 provides the interrupt request function via an IRQ pin. Any video loss, motion, blind, and night detection, status change, etc., will make IRQ pin low. There are total of 64 interrupt sources in TW2851, with the INTERRUPT\_VECT shown in register 0x1D0 to 0x1D7. Each bit of these registers represents one interrupt source. To simplify the host polling effort, every 8 sources are further summarized in a second interrupt status at register 0x1E0. In this status, if bit m is "1", it means there are at least one source in 0x1Dm triggered the IRQ pin. In order to clear the interrupt vector, simply write a "1" into the corresponding bit location of the source into the INTERRUPT\_VECT.

Associated with the 64 bit INTERRUPT\_VECT, there are also 64 bit INTERRUPT\_VECT\_MASK that can be set to "0" to mask out the interrupt source from triggering the IRQ pin. Note that this masking does not reset the INTERRUPT\_VECT. The host can still read the status of the masked sources from INTERRUPT\_VECT.

For the list of interrupt sources corresponding to each of the INTERRUPT\_VECT bit, please refer to the description in the register description section.

## BURST INTERFACE TO DDR SDRAM

TW2851 provides a burst circuit to allow CPU to burst read/write data from host interface to the external DDR memory. This is useful for testing the external DDR memory. It is also used in writing the customized cursor bitmap into DDR or reading the bitmap from DDR into the on-chip cursor SRAM.

To write data to DDR, do the following.

1. Write 0x2E0 / 0x2E1 / 0x2E2 with the DDR address to be accessed. The DDR address here is in units of 2 bytes.
2. Write 0x2E3 / 0x2E4 with DMA length. This length can be 1 byte up to 1024 bytes. Internally, the DDR burst is done 64 bytes by 64 bytes until it reaches the length specified here. The last burst can be less than 64 bytes. The number of times the CPU writes in the last burst has to be exactly as specified by this length. Note the DDR interface burst length is in unit of 4 bytes. So if the last DDR burst length is not multiple of 4 bytes, the DDR still burst up to multiple of 4 bytes. Some garbage data up to 3 bytes can be written into the DDR in the last DDR burst.
3. Write an AUX\_DDR\_WR command at 0x2E4 bit 0. This bit will be self cleared after done.
4. If the CPU parallel interface has P\_WAIT signal, go ahead to start writing the 0x2DF address with the data for AUX\_DDR\_LENGTH bytes. (This can be performed by the DMA engine at the CPU side).
5. If the CPU parallel interface has no P\_WAIT signal, poll the AUX\_FIFO\_EMPTY bit at 0x2E4 bit 3. Wait until this bit is set.
6. Repeat (4) or (5) as needed until total bytes up to the number specified previously in DMA length in register 0x2E3/0x2E4. The last burst may be less than 64 bytes. After the last burst, the AUX\_DDR\_WR command at 0x2E4 will be self-cleared. Note that before a full length is written, the

CPU should not switch from write to read. Do not read 0x2DF until the burst write transaction is done.

To read data from DDR, do the following:

1. Write 0x2E0 / 0x2E1 / 0x2E2 with the DDR address to be accessed. The DDR address here is in units of 2 bytes.
2. Write 0x2E3 / 0x2E4 with DMA length. This length can be 1 byte up to 1024 bytes. Internally, the DDR burst is done 64 bytes by 64 bytes until it reaches the length specified here. The last burst can be less than 64 bytes. The number of times the CPU read in the last DDR burst has to exactly as specified by this length.
3. Write an AUX\_DDR\_RD command at 0x2E4 bit 1. This bit will be self cleared after done.
4. If the CPU parallel interface has P\_WAIT signal, go ahead to start reading the 0x2DF address with the data for AUX\_DDR\_LENGTH bytes. (This can be performed by the DMA engine at the CPU side).
5. If the CPU parallel interface has no P\_WAIT signal, poll the AUX\_FIFO\_FULL bit at 0x2E4 bit 2. Wait until this bit is set, and proceed to read either 64 bytes (before the last DDR burst), or a length in the last DDR burst consistent with the DMA length set in register 0x2E3/0x2E4.
6. Repeat (4) or (5) as needed.

Note that before a full length is read, the CPU should not switch from read to write. Do not write 0x2DF until the burst read transaction is done.

## External DRAM Interface

TW2851 uses a unified external DDR SDRAM for various functions, such as video buffers, bit-mapped OSG, customized cursor bitmap, etc. The memory controller of the TW2851 supports 16bit data width up to 166 MHz clock rate. The memory capacity is 32 Mbytes.

When the chip is powered up, the CPU is responsible for setting all the on-chip configuration registers for DDR memory configuration. Once the registers are set, the CPU releases the software reset signal, then the DDR memory controller initializes the DDR memory configuration using the parameters in the registers. After the initialization is done, the DDR memory is ready for use. After the initialization, the memory controller does the memory refresh automatically.

## Chip Reset / Initiation

TW2851 uses two reset signals: a hardware reset pin RST\_N, and a software reset SOFT\_RSTN register. (0x2F0 bit 7). When the hardware reset RST\_N pin is asserted, the whole chip is reset. When the software reset register is asserted, the whole chip except all the on-chip configuration registers are reset. The content in the on-chip register is not cleared by software reset. With this, TW2851 allows the micro-controller to first release the hardware reset, and start configuring all the registers, and then release the software reset to start normal operation.

In addition to the software reset, there is another register bit used for on-chip DLL reset. (0x2F0 bit 6) This allows the CPU to control the on-chip DLL used by the DDR memory controller.

The programming sequence is as follows:

- After PCB powered on, the hardware reset is released by hardware.
- Initially the chip is in reset state. SOFT\_RSTN (0x2F0 bit 7) is 0, DLL\_RST (0x2F0 bit 6) is 1.
- Release the DLL\_RST afterward (Set DLL\_RST to 1'b0).
- Start configuring all the registers, especially the DDR configuration.

- Then released the SOFT\_RSTN (Set SOFT\_RSTN to 1'b1). After SOFT\_RSTN is released, the DDR controller start configuring the external DDR memory based on the setting in the register.
- The chip is ready for normal operation.

## Frequency Synthesizer Setup

There are three frequency synthesizers on TW2851. One is for DDR memory clock, one is for the VGA / LCD panel clock, and the other is for generating the system clocks of 108 MHz. All the frequency synthesizers use the same input clock (crystal or oscillator) of 27 MHz.

The frequency synthesizer for DDR memory clock generates a DDR clock of 166 MHz. The VGA clock depends on the VGA resolution as defined in the VESA standard. The LCD panel clock depends on the make of the LCD panel.

From the 27 MHz, an output clock frequency can be generated with the following equation.

$$\text{Clock Frequency} = \frac{27 \text{ MHz} \times 2^x \times F[7:0]}{R * NO}$$

The Panel Clock configuration registers are at 0xEB0 ~ 0xEB2. The Memory Clock configuration registers are at 0xEB4 ~ 0xEB6.

The third frequency synthesizer is a simpler one that only enhances the clock by 4X into 108 MHz. Other video clocks such as 54 MHz, 27MHz, and 13.5 MHz are derived from 108 MHz.

## Register Description by Function

### CVBS Video Input

#### VIDEO DECODER

#	Address	[7]	[6]	[5]	[4]	[3]	[2]	[1]	[0]
0	0x000	VDLOSS*	HLOCK*	SLOCK*	FLD*	VLOCK*	NOVIDEO*	MONO*	DET50*
1	0x010								
2	0x020								
3	0x030								

\* Read only bits

VDLOSS	1	Video not present. (Sync is not detected in number of consecutive line periods specified by MISSCNT register)
	0	Video detected.
HLOCK	1	Horizontal sync PLL is locked to the incoming video source.
	0	Horizontal sync PLL is not locked.
SLOCK	1	Sub-carrier PLL is locked to the incoming video source.
	0	Sub-carrier PLL is not locked.
FLD	1	Even field is being decoded.
	0	Odd field is being decoded.
VLOCK	1	Vertical logic is locked to the incoming video source.
	0	Vertical logic is not locked.
NOVIDEO		Reserved for TEST.
MONO	1	No color burst signal detected.
	0	Color burst signal detected.
DET50	0	60Hz source detected
	1	50Hz source detected
		The actual vertical scanning frequency depends on the current standard invoked.

#	Address	[7]	[6]	[5]	[4]	[3]	[2]	[1]	[0]
0	0x001	VCR*	WKAIR*	WKAIR1*	VSTD*	NINTL*	VSHP		
1	0x011								
2	0x021								
3	0x031								

\* Read only bits

VCR	VCR signal indicator
WKAIR	Weak signal indicator 2.
WKAIR1	Weak signal indicator controlled by WKTH
VSTD	1 = Standard signal 0 = Non-standard signal
NINTL	1 = Non-interlaced signal 0 = interlaced signal
VSHP	Vertical Sharpness Control 0 = None (default) 7 = Highest **Note: VSHP must be set to '0' if COMB = 0

#	Address	[7]	[6]	[5]	[4]	[3]	[2]	[1]	[0]
0	0x006	0	0	VACTIVE_ XY[8]	VDELAY_ XY[8]	HACITIVE_XY[9:8]	HDELAY_XY[9:8]		
1	0x016								
2	0x026								
3	0x036								
0	0x002	HDELAY_XY[7:0]							
1	0x012								
2	0x022								
3	0x032								

HDELAY_XY	This 10bit register defines the starting location of horizontal active pixel for display / record path. A unit is 1 pixel. The default value is 0x00F for NTSC and 0x00A for PAL.
-----------	---

#	Address	[7]	[6]	[5]	[4]	[3]	[2]	[1]	[0]
0	0x006	0	0	VACTIVE_ XY[8]	VDELAY_ XY[8]	HACTIVE_XY[9:8]	HDELAY_XY[9:8]		
1	0x016								
2	0x026								
3	0x036								
0	0x003	HACTIVE_XY[7:0]							
1	0x013								
2	0x023								
3	0x033								

**HACTIVE\_XY**

This 10bit register defines the number of horizontal active pixel for display / record path. A unit is 1 pixel. The default value is decimal 720.

#	Address	[7]	[6]	[5]	[4]	[3]	[2]	[1]	[0]
0	0x006	0	0	VACTIVE_ XY[8]	VDELAY_ XY[8]	HACTIVE_XY[9:8]	HDELAY_XY[9:8]		
1	0x016								
2	0x026								
3	0x036								
0	0x004	VDELAY_XY[7:0]							
1	0x014								
2	0x024								
3	0x034								

**VDELAY\_XY**

This 9bit register defines the starting location of vertical active for display / record path. A unit is 1 line. The default value is decimal 6.

#	Address	[7]	[6]	[5]	[4]	[3]	[2]	[1]	[0]
0	0x006	0	0	VACTIVE_ XY[8]	VDELAY_ XY[8]	HACTIVE_XY[9:8]	HDELAY_XY[9:8]		
1	0x016								
2	0x026								
3	0x036								
0	0x005	VACTIVE_XY[7:0]							
1	0x015								
2	0x025								
3	0x035								

**VACTIVE\_XY**

This 9bit register defines the number of vertical active lines for display / record path. A unit is 1 line. The default value is decimal 240.

#	Address	[7]	[6]	[5]	[4]	[3]	[2]	[1]	[0]
0	0x007	HUE							
1	0x017								
2	0x027								
3	0x037								

**HUE**

These bits control the color hue as 2's complement number. They have value from +36° (7Fh) to -36° (80h) with an increment of 2.8°. The 2 LSB has no effect. The positive value gives greenish tone and negative value gives purplish tone. The default value is 0° (00h). This is effective only on NTSC system. The default is 00h.

#	Address	[7]	[6]	[5]	[4]	[3]	[2]	[1]	[0]
0	0x008	SCURVE	VSF	CTI		SHARPNESS			
1	0x018								
2	0x028								
3	0x038								

**SCURVE**

This bit controls the center frequency of the peaking filter. The corresponding gain adjustment is HFLT.

0 Low  
1 center

**VSF**

This bit is for internal used. The default is 0.

**CTI**

CTI level selection. The default is 1.

0 None  
3 Highest

**SHARPNESS**

These bits control the amount of sharpness enhancement on the luminance signals. There are 16 levels of control with '0' having no effect on the output image. 1 through 15 provides sharpness enhancement with 'F' being the strongest. The default is 1.

#	Address	[7]	[6]	[5]	[4]	[3]	[2]	[1]	[0]
0	0x009	CNRST							
1	0x019								
2	0x029								
3	0x039								

**CNRST**

These bits control the luminance contrast gain. A value of 100 (64h) has a gain of 1. The range adjustment is from 0% to 255% at 1% per step. The default is 64h.



VIN	Address	[7]	[6]	[5]	[4]	[3]	[2]	[1]	[0]
0	0x00A	BRIGHT							
1	0x01A								
2	0x02A								
3	0x03A								

**BRIGHT**

These bits control the brightness. They have value of  $-128$  to  $127$  in 2's complement form. Positive value increases brightness. A value 0 has no effect on the data. The default is 00h.

#	Address	[7]	[6]	[5]	[4]	[3]	[2]	[1]	[0]
0	0x00B	SAT_U							
1	0x01B								
2	0x02B								
3	0x03B								

**SAT\_U**

These bits control the digital gain adjustment to the U (or Cb) component of the digital video signal. The color saturation can be adjusted by adjusting the U and V color gain components by the same amount in the normal situation. The U and V can also be adjusted independently to provide greater flexibility. The range of adjustment is 0 to 200%. A value of 128 (80h) has gain of 100%. The default is 80h.

#	Address	[7]	[6]	[5]	[4]	[3]	[2]	[1]	[0]
0	0x00C	SAT_V							
1	0x01C								
2	0x02C								
3	0x03C								

**SAT\_V**

These bits control the digital gain adjustment to the V (or Cr) component of the digital video signal. The color saturation can be adjusted by adjusting the U and V color gain components by the same amount in the normal situation. The U and V can also be adjusted independently to provide greater flexibility. The range of adjustment is 0 to 200%. A value of 128 (80h) has gain of 100%. The default is 80h.

#	Address	[7]	[6]	[5]	[4]	[3]	[2]	[1]	[0]
0	0x00D	SF*	PF*	FF*	KF*	CSBAD*	MCVSN*	CSTRIPE*	CTYPE2*
1	0x01D								
2	0x02D								
3	0x03D								

\* Read only bits

SF This bit is for internal use

PF This bit is for internal use

FF This bit is for internal use

KF This bit is for internal use

CSBAD 1 Macrovision color stripe detection may be un-reliable

MCVSN 1 Macrovision AGC pulse detected.  
0 Not detected.

CSTRIPE 1 Macrovision color stripe protection burst detected.  
0 Not detected.

CTYPE2 This bit is valid only when color stripe protection is detected, i.e. if CSTRIPE=1,  
1 Type 2 color stripe protection  
0 Type 3 color stripe protection

#	Address	[7]	[6]	[5]	[4]	[3]	[2]	[1]	[0]
0	0x00E	DETSTUS*		STDNOW*		ATREG			STANDARD
1	0x01E								
2	0x02E								
3	0x03E								

\* Read only bits

<b>DETSTUS</b>	<b>0</b>	Idle
	<b>1</b>	detection in progress
<b>STDNOW</b>		Current standard invoked
	<b>0</b>	NTSC(M)
	<b>1</b>	PAL (B,D,G,H,I)
	<b>2</b>	SECAM
	<b>3</b>	NTSC4.43
	<b>4</b>	PAL (M)
	<b>5</b>	PAL (CN)
	<b>6</b>	PAL 60
	<b>7</b>	Not valid
<b>ATREG</b>	<b>1</b>	Disable the shadow registers
	<b>0</b>	Enable VACTIVE and HDELAY shadow registers value depending on STANDARD. (Default)
<b>STANDARD</b>		Standard selection
	<b>0</b>	NTSC(M)
	<b>1</b>	PAL (B,D,G,H,I)
	<b>2</b>	SECAM
	<b>3</b>	NTSC4.43
	<b>4</b>	PAL (M)
	<b>5</b>	PAL (CN)
	<b>6</b>	PAL 60
	<b>7</b>	Auto detection (Default)

#	Address	[7]	[6]	[5]	[4]	[3]	[2]	[1]	[0]
0	0x00F	ATSTART	PAL60EN	PALCNEN	PALMEN	NTSC44EN	SECAMEN	PALBEN	NTSCEN
1	0x01F								
2	0x02F								
3	0x03F								

ATSTART	1	Writing 1 to this bit will manually initiate the auto format detection process. This bit is a self-clearing bit
	0	Manual initiation of auto format detection is done. (Default)
PAL60EN	1	Enable recognition of PAL60 (Default)
	0	Disable recognition
PALCNEN	1	Enable recognition of PAL (CN). (Default)
	0	Disable recognition
PALMEN	1	Enable recognition of PAL (M). (Default)
	0	Disable recognition
NTSC44EN	1	Enable recognition of NTSC 4.43. (Default)
	0	Disable recognition
SECAMEN	1	Enable recognition of SECAM. (Default)
	0	Disable recognition
PALBEN	1	Enable recognition of PAL (B,D,G,H,I). (Default)
	0	Disable recognition
NTSCEN	1	Enable recognition of NTSC (M). (Default)
	0	Disable recognition

Address	[7]	[6]	[5]	[4]	[3]	[2]	[1]	[0]
0x045	0	0	VSMODE	FLDPOL	HSPOL	VSPOL	DECVSMODE	DECFLDPOL

<b>VSMODE</b>	Control the VS and field flag timing
0	VS and field flag is aligned with vertical sync of incoming video (Default)
1	VS and field flag is aligned with HS
<b>FLDPOL</b>	Select the FLD polarity
0	Odd field is high
1	Even field is high (Default)
<b>HSPOL</b>	Select the HS polarity
0	Low for sync duration (Default)
1	High for sync duration
<b>VSPOL</b>	Select the VS polarity
0	Low for sync duration (Default)
1	High for sync duration
<b>DECVSMODE</b>	0 Default
<b>DECFLDPOL</b>	0 Default

Address	[7]	[6]	[5]	[4]	[3]	[2]	[1]	[0]
0x046	AGCEN4	AGCEN3	AGCEN2	AGCEN1	AGCGAIN4[8]	AGCGAIN3[8]	AGCGAIN2[8]	AGCGAIN1[8]
0x047	AGCGAIN1[7:0]							
0x048	AGCGAIN2[7:0]							
0x049	AGCGAIN3[7:0]							
0x04A	AGCGAIN4[7:0]							

**AGCENn** Select Video AGC loop function on VIN of channel n  
**0** AGC loop function enabled (recommended for most application cases) (default).  
**1** AGC loop function disabled. Gain is set by AGCGAINn

**AGCGAINn** These registers control the AGC gain of channel n when AGC loop is disabled. Default value is 0F0h.

Address	[7]	[6]	[5]	[4]	[3]	[2]	[1]	[0]
0x04B	PD_BIAS	V_ADC_SAVE			0	0	0	YFLEN

**PD\_BIAS** **1** Power down the bias of all 4 VADC  
**0** Do not power down the bias

**V\_ADC\_SAVE** Power Saving Mode Selection.  
**0** Most Power Consuming  
**7** Most Power Saving

**IREF** **0** Internal current reference 1 for Video ADC (default)  
**1** Internal current reference increase 30% for Video ADC.

**VREF** **0** Internal voltage reference for Video ADC (default)  
**1** Internal voltage reference shut down for Video ADC

**YFLEN** Analog Video CH1/CH2/CH3/CH4 anti-alias filter control  
**1** Enable(default)  
**0** Disable

Address	[7]	[6]	[5]	[4]	[3]	[2]	[1]	[0]
0x04D	TST_ADC_VD1	ADC_SEL1			0	0	0	0

TST\_ADC\_VD1                    0      Default

ADC\_SEL1                        0      Default

Address	[7]	[6]	[5]	[4]	[3]	[2]	[1]	[0]
0x04E	TST_ADC_VD2	ADC_SEL2			0	0	0	0

TST\_ADC\_VD2                    0      Default

ADC\_SEL2                        0      Default

Address	[7]	[6]	[5]	[4]	[3]	[2]	[1]	[0]
0x04F	FRM		YNR		CLMD		PSP	

FRM                                Free run mode control  
 0      Auto(default)  
 2      Default to 60Hz  
 3      Default to 50Hz

YNR                                Y HF noise reduction  
 0      None(default)  
 1      Smallest  
 2      Small  
 3      Medium

CLMD                              Clamping mode control  
 0      Sync top  
 1      Auto(default)  
 2      Pedestal  
 3      N/A

PSP                                Slice level control  
 0      Low  
 1      Medium(default)  
 2      High

Address	[7]	[6]	[5]	[4]	[3]	[2]	[1]	[0]
0x050	HFLT2				HFLT1			
0x051	HFLT4				HFLT3			

HFLTn

HFLTn controls the peaking function of channel n. Reserved for test purpose.

Address	[7]	[6]	[5]	[4]	[3]	[2]	[1]	[0]
0x052	CTEST	YCLN	0	AFLTEN	GTEST	VLPF	CKLY	CKLC

CTEST

Clamping control for debugging use. (Test purpose only)  
(default 0)

YCLN

1	Y channel clamp disabled (Test purpose only)
0	Enabled (default)

AFLTEN

1	Analog Audio input Anti-Aliasing Filter enabled (default)
0	Disabled

GTEST

1	Test (Test purpose only)
0	Normal operation (default)

VLPF

Clamping filter control (default 0)

CKLY

Clamping current control 1 (default 0)

CKLC

Clamping current control 2 (default 0)

Address	[7]	[6]	[5]	[4]	[3]	[2]	[1]	[0]
0x053	NT502	NT501						

NT501

1	Force the Video Decoder 1 to a special NTSC 50 Hz format
0	Do not force to NTSC 50 Hz format

NT502

1	Force the Video Decoder 2 to a special NTSC 50 Hz format
0	Do not force to NTSC 50 Hz format



Address	[7]	[6]	[5]	[4]	[3]	[2]	[1]	[0]
0x054	NT504	NT503	DIV_RST	DOUT_RST	ACALEN	AADC_SAVE		

NT503	1	Force the Video Decoder 4 to a special NTSC 50 Hz format
	0	Do not force to NTSC 50 Hz format
NT504	1	Force the Video Decoder 4 to a special NTSC 50 Hz format
	0	Do not force to NTSC 50 Hz format
DIV_RST		Audio ADC divider reset. This bit must be set to 0 again after reset.
DOUT_RST		Audio ADC digital output reset for all channel. This bit must be setup up to 0 again after reset.
ACALEN		Audio ADC Calibration control. This be must be set up to 0 again after enabled.
AADC_SAVE		Audio ADC Power Saving Mode. 7 is most power saving.

Address	[7]	[6]	[5]	[4]	[3]	[2]	[1]	[0]
0x055	FLD*				VAV*			

FLD		Status of the field flag for corresponding channel ( <i>Read only</i> ) FLD[3:0] are FIELD ID for VIN3 to VIN0. 0 Odd field when FLDPOL (0x045) = 1 1 Even field when FLDPOL (0x045) = 1
VAV		Status of the vertical active video signal for corresponding channel ( <i>Read only</i> ). VAV[3:0] are Vertical Active Video Signal for VIN3 to VIN0. 0 Vertical blanking time 1 Vertical active time

Address	[7]	[6]	[5]	[4]	[3]	[2]	[1]	[0]
0x057	SHCOR				ANA_SW4	ANA_SW3	ANA_SW2	ANA_SW1

SHCOR		These bits provide coring function for the sharpness control (default 3h)
ANA_SWn		Control the analog input channel switch for VIN1 to VIN4 input 0 VIN_A channel is selected (default) 1 VIN_B channel is selected

Address	[7]	[6]	[5]	[4]	[3]	[2]	[1]	[0]
0x058	PBW	DEM	PALSW	SET7	COMB	HCOMP	YCOMB	PDLY

PBW	1	Wide Chroma BPF BW (Default)
	0	Normal Chroma BPF BW
DEM	Reserved (Default 1)	
PALSW	1	PAL switch sensitivity low.
	0	PAL switch sensitivity normal (Default)
SET7	1	The black level is 7.5 IRE above the blank level.
	0	The black level is the same as the blank level (Default)
COMB	1	Adaptive comb filter for NTSC and PAL (Recommended). This setting is not for SECAM (Default)
	0	Notch filter. For SECAM, always set to 0.
HCOMP	1	Operation mode 1 (Recommended) (Default)
	0	Mode 0
YCOMB	1	Bypass Comb filter when no burst presence
	0	No bypass (Default)
PDLY	0	Enable PAL delay line (default)
	1	Disable PAL delay line

Address	[7]	[6]	[5]	[4]	[3]	[2]	[1]	[0]
0x059	GMEN	CKHY	HSDLY					

GMEN	Reserved (Default 0)	
CKHY	Color killer hysteresis.	
	0	Fastest (Default)
	1	Fast
	2	Medium
	3	Slow
HSDLY	Reserved for test	

Address	[7]	[6]	[5]	[4]	[3]	[2]	[1]	[0]
0x05A	CTCOR		CCOR		VCOR		CIF	

CTCOR	These bits control the coring for CTI (Default 1h)
CCOR	These bits control the low level coring function for the Cb/Cr output (Default 0h)
VCOR	These bits control the coring function of vertical peaking (Default 1h)
CIF	These bits control the IF compensation level. 0 None(default) 1 1.5dB 2 3dB 3 6dB

Address	[7]	[6]	[5]	[4]	[3]	[2]	[1]	[0]
0x05B	CLPEND				CLPST			

CLPEND	These 4 bits set the end time of the clamping pulse. Its value should be larger than the value of CLPST (Default 5h)
CLPST	These 4 bits set the start time of the clamping. It is referenced to PCLAMP position. (Default 0h)

Address	[7]	[6]	[5]	[4]	[3]	[2]	[1]	[0]
0x05C	NMGAIN				WPGAIN			FC27

NMGAIN	These bits control the normal AGC loop maximum correction value (Default 4h)
WPGAIN	Peak AGC loop gain control (Default 1h)
FC27	1 Normal ITU-R656 operation (Default) 0 Squared Pixel mode for test purpose only

Address	[7]	[6]	[5]	[4]	[3]	[2]	[1]	[0]
0x05D	PEAKWT							

PEAKWT	These bits control the white peak detection threshold. Setting 'FF' can disable this function (Default D8h)
--------	---

Address	[7]	[6]	[5]	[4]	[3]	[2]	[1]	[0]
0x05E	CLMPLD		CLMPL					

CLMPLD                      0      Clamping level is set by CLMPL  
                                   1      Clamping level preset at 60d (Default)

CLMPL                      These bits determine the clamping level of the Y channel (Default 3Ch)

Address	[7]	[6]	[5]	[4]	[3]	[2]	[1]	[0]
0x05F	SYNCTD		SYNCT					

SYNCTD                     0      Reference sync amplitude is set by SYNCT  
                                   1      Reference sync amplitude is preset to 38h (Default)

SYNCT                      These bits determine the standard sync pulse amplitude for AGC reference (Default 38h)

Address	[7]	[6]	[5]	[4]	[3]	[2]	[1]	[0]
0x0C0	BGNDEN				BGNDCOL	AUTO_BGND	LIM_656	0

BGNDEN[n]                Enable the background color for channel n for byte-interleave video decoder output.  
                                   0      Background color is disabled (Default)  
                                   1      Background color is enabled

BGNDCOL                 Select the background color when BGNDEN = "1" or when AUTO\_BGND = "1" and Video Loss is detected  
                                   0      Blue color (Default)  
                                   1      Black color

AUTO\_BGND                Select the decoder background mode for byte-interleave video decoder output.  
                                   0      Manual background mode (Default)  
                                   1      Automatic background mode when No-video is detected

LIM\_656                    Clamp the Y and C value in the video stream  
                                   0      Maximum of Y is 254, Minimum of Y is 1  
     Maximum of C is 254, Minimum of Y is 1  
                                   1      Maximum of Y is 235, Minimum of Y is 16  
     Maximum of Y is 240, Minimum of Y is 16

Address	[7]	[6]	[5]	[4]	[3]	[2]	[1]	[0]
0x0C1	0	OUT_CHID	SAV_CHID	TST_EHAV_BLK	0	0	0	0

<b>TST_EHAV_BLK</b>	Testing purpose only 1 Force the Y value to be 0 when HAV is high. 0 Normal Operation
<b>OUT_CHID</b>	Enable the channel ID format in the horizontal blanking period of Record Bypass byte interleaving BT 656 stream 0 Disable the channel ID format (default) 1 Enable the channel ID format The lowest 4 bits of Y and C pixel value during horizontal blanking is Bit 3 Video Loss Bit 2 Analog Mux A/B Bit 1-0 Port ID
<b>SAV_CHID</b>	Enable the channel ID format in the SAV/EAV header in Record Bypass byte interleaving BT656 stream 0 Disable the channel ID format (default) 1 Enable the channel ID format  The SAV/EAV format is FF, 00, 00, XX When SAV_CHID is enabled, the bits in XX is  Bit 7 Detect Video Bit 1:0 Port ID

Address	[7]	[6]	[5]	[4]	[3]	[2]	[1]	[0]
0x0E7	HASYNC		OFDLY		DECOUTMD	0	0	0

<b>HASYNC</b>	1 The length of EAV to SAV is set up and fixed by HBLEN register 0 The length of SAV to EAV is setup and fixed by HACTIVE registers
<b>OFDLY</b>	FIELD output delay 0h 0H line delay FIELD output (601 mode only) 1h~6h 1H ~ 6H line delay FIELD output 7h Reserved
<b>DECOUTMD</b>	Default 1

Address	[7]	[6]	[5]	[4]	[3]	[2]	[1]	[0]
0x0E8	HBLLEN							

**HBLLEN**

These bits are effective when HASYNC bit is set to 1. These bits setup the length of EAV to SAV code when HASYNC bit is 1. Normal value is (Total pixel per line – HACTIVE) value.

NTSC/PAL-M(60Hz)      8Ah = 858 – 720  
 PAL/SECAM(50Hz)      90h = 864 – 720

If register 0x00E[3] (ATREG for CH1) is set to 0, this value changes into 8Ah or 90h at audio video format detection initial time automatically according to CH1 video detection status.

Address	[7]	[6]	[5]	[4]	[3]	[2]	[1]	[0]
0x0E9	CKLM	YDLY			0	0	0	0

**CKLM**

Color Killer mode.

0      Normal (Default)  
 1      Fast (For special application)

**TDLY**

Luma delay fine adjustment. This 2's complement number provides –4 to +3 unit delay control (Default 3h)

Address	[7]	[6]	[5]	[4]	[3]	[2]	[1]	[0]
0x0EA	0	0	ADECRST	0	VDEC4RST	VDEC3RST	VDEC2RST	VDEC1RST

**ADECRST**

A 1 written to this bit resets the audio portion to its default state but all register content remains unchanged. This bit is self-cleared.

**VDECnRST**

A 1 written to this bit resets the VINn path Video Decoder portion to its default state but all register content remain unchanged. This bit is self cleared.

Address	[7]	[6]	[5]	[4]	[3]	[2]	[1]	[0]
0x0EB	MISSCNT				HSWIN			

**MISSCNT**

These bits set the threshold for horizontal sync miss count threshold (Default 4h)

**HSWIN**

These bits determine the VCR mode detection threshold (Default 4h)

Address	[7]	[6]	[5]	[4]	[3]	[2]	[1]	[0]
0x0EC	PCLAMP							

**PCLAMP**

These bits set the clamping position from the PLL sync edge (Default 2Ah)

Address	[7]	[6]	[5]	[4]	[3]	[2]	[1]	[0]
0x0ED	VLCKI		VLCKO		VMODE	DETV	AFLD	VINT

VLCKI	Vertical lock in time 0 Fastest (Default) : 3 Slowest.
VLCKO	Vertical lock out time 0 Fastest (Default) : 3 Slowest
VMODE	This bit controls the vertical detection window 1 Search mode 0 Vertical countdown mode (Default)
DETV	1 Recommended for special application only 0 Normal Vsync logic (Default)
AFLD	Auto field generation control 0 Off (Default) 1 On
VINT	Vertical integration time control 1 Short 0 Normal (Default)

Address	[7]	[6]	[5]	[4]	[3]	[2]	[1]	[0]
0x0EE	BSHT			VSHT				

BSHT	Burst PLL center frequency control (Default 0h)
VSHT	Vsync output delay control in the increment of half line length (Default 0h)

Address	[7]	[6]	[5]	[4]	[3]	[2]	[1]	[0]
0x0EF	CKILLMAX		CKILLMIN					

**CKILLMAX**                      These bits control the amount of color killer hysteresis. The hysteresis amount is proportional to the value (Default 1h)

**CKILLMIN**                      These bits control the color killer threshold. Larger value gives lower killer level (Default 28h)

Address	[7]	[6]	[5]	[4]	[3]	[2]	[1]	[0]
0x0F0	COMBMD	HTL		VTL				

**COMBMD**                      0      Adaptive mode (Default)  
    1      Fixed comb

**HTL**                                Adaptive Comb filter threshold control 1 (Default 4h)

**VTL**                                Adaptive Comb filter threshold control 2 (Default Ch)

Address	[7]	[6]	[5]	[4]	[3]	[2]	[1]	[0]
0x0F1	HPLC	EVCNT	PALC	SDET	0	BYPASS	0	0

**HPLC**                                Reserved for internal use (Default 0)

**EVCNT**                            1      Even field counter in special mode  
    0      Normal operation (Default)

**PALC**                                Reserved for future use (Default 0)

**SDET**                                ID detection sensitivity. A '1' is recommended (Default 1)

**BYPASS**                            It controls the standard detection and should be set to '1' in normal use (Default 1)



Address	[7]	[6]	[5]	[4]	[3]	[2]	[1]	[0]
0x0F2	HPM		ACCT		SPM		CBW	

HPM	Horizontal PLL acquisition time. 0 Normal 1 Auto2 2 Auto1 (Default) 3 Fast
ACCT	ACC time constant 0 No ACC 1 Slow 2 Medium (Default) 3 Fast
SPM	Burst PLL control 0 Slowest 1 Slow (Default) 2 Fast 3 Fastest
CBW	Chroma low pass filter bandwidth control. Refer to filter curves (Default 1)

Address	[7]	[6]	[5]	[4]	[3]	[2]	[1]	[0]
0x0F3	NKILL	PKILL	SKILL	CBAL	FCS	LCS	CCS	BST

NKILL	1	Enable noisy signal color killer function in NTSC mode (Default)
	0	Disabled
PKILL	1	Enable automatic noisy color killer function in PAL mode (Default)
	0	Disabled
SKILL	1	Enable automatic noisy color killer function in SECAM Mode (Default)
	0	Disabled
CBAL	0	Normal output (Default)
	1	Special output mode.
FCS	1	Force decoder output value determined by CCS
	0	Disabled (Default)
LCS	1	Enable pre-determined output value indicated by CCS when video loss is detected
	0	Disabled (Default)
CCS	When FCS is set high or video loss condition is detected when LCS is set high, one of two colors display can be selected.	
	1	Blue color
	0	Black (Default)
BST	1	Enable blue stretch
	0	Disabled (Default)

Address	[7]	[6]	[5]	[4]	[3]	[2]	[1]	[0]
0x0F4	0	0	MONITOR					
0x0F5	HREF*							

These registers are for test purpose only. The MONITOR is used to select the HREF status of a certain video decoder port in Reg0x0F5 HREF

MONITOR Value	Select video decoder port for register 0x0F5
00h	VIN0 Video Decoder Path HREF[9:2] value
10h	VIN1 Video Decoder Path HREF[9:2] value
20h	VIN2 Video Decoder Path HREF[9:2] value
30h	VIN3 Video Decoder Path HREF[9:2] value

Address	[7]	[6]	[5]	[4]	[3]	[2]	[1]	[0]
0x0F6	0		CVSTD1*					CVFMT1
0x0F7	0		CVSTD2*					CVFMT2
0x0F8	0		CVSTD3*					CVFMT3
0x0F9	0		CVSTD4*					CVFMT4

CVSTDn  
CVFMTn

Address	[7]	[6]	[5]	[4]	[3]	[2]	[1]	[0]
0x0FA		IDX1						NSEN1/SSEN1/PSEN1/WKTH1
0x0FB		IDX2						NSEN2/SSEN2/PSEN2/WKTH2
0x0FC		IDX3						NSEN3/SSEN3/PSEN3/WKTH3
0x0FD		IDX4						NSEN4/SSEN4/PSEN4/WKTH4

NSENn/SSENn/PSENn/WKTHn shared the same 6 bits in the register. IDXn is used to select which of the four parameters is being controlled. The write sequence is a two steps process unless the same register is written. A write of {ID,000000} selects one of the four registers to be written. A subsequent write will actually write into the register. (Default 0h)

IDXn	0	Controls the NTSC color carrier detection sensitivity (NSENn) (Default 1Ah)
	1	Controls the SECAM ID detection sensitivity (SSENn) (Default 20h)
	2	Controls the PAL ID detection sensitivity (PSENn) (Default 1Ch)
	3	Controls the weak signal detection sensitivity (WKTHn) (Default 2Ah)

Address	[7]	[6]	[5]	[4]	[3]	[2]	[1]	[0]
0x0FE								DEV_ID *
								REV_ID *

\* Read only

DEV\_ID                      The TW2851 product ID code is 01000

REV\_ID                      The revision number is 0h

Address	[7]	[6]	[5]	[4]	[3]	[2]	[1]	[0]
0x340	VDLOSS_TH1				VDLOSS_TH0			
0x341	VDLOSS_TH3				VDLOSS_TH2			

**VDLOSS\_THn**

Adjust the video loss signal presented to the backend modules from video decoder 0, 1, 2, and 3.

- 0 The backend video loss signal is the same as the video decoder video loss signal.
- 1 - 14 The backend video loss signal is asserted only when video decoder video loss signal is asserted for more than VDLOSS\_THx fields.
- 15 The backend video loss signal is never asserted regardless of the Video decoder video loss signal.

**INTERNAL PATTERN GENERATOR**

Address	[7]	[6]	[5]	[4]	[3]	[2]	[1]	[0]
0x303	0	1	PTRN_LIM_656	PTRN_SMALL	PTRN_CHIP_ID		PTRN_PAL	PTRN_EN

**PTRN\_LIM\_656**

Limit the pixel value generated by the internal pattern generator after the video decoder.

- 1 Limit Y to 235 maximum, 16 minimum
- 0 Do not limit

**PTRN\_SMALL**

Internal pattern generator generates small frame. For simulation only

**PTRN\_CHIP\_ID**

Specify the chip ID of this chip

**PTRN\_PAL**

- 1 Internal pattern generator generates PAL pattern
- 0 Internal pattern generator generates NTSC pattern

**PTRN\_EN**

Enable Internal pattern generator to replace the video stream from video decoder

- 1 Enable the pattern generator
- 0 Use the video decoder input

Address	[7]	[6]	[5]	[4]	[3]	[2]	[1]	[0]
0x304	0	0	0	0	PTRN_VIDEO_LOSS			

**PTRN\_VIDEO\_LOSS**

Generate the video loss signal from the internal pattern generator

- 1 Video Loss
- 0 Video detected

## NOISE REDUCTION

Address	[7]	[6]	[5]	[4]	[3]	[2]	[1]	[0]
0x305	0	BP_NR_2S	BP_NR_2Y	BP_NR_2X	0	BP_NR_1S	BP_NR_1Y	BP_NR_1X
0x306	0	BP_NR_4S	BP_NR_4Y	BP_NR_4X	0	BP_NR_3S	BP_NR_3Y	BP_NR_3X

**BP\_NR\_nX**                      Bypass the noise reduction of display path for port n  
**1**                      Bypass  
**0**                      Do not bypass

**BP\_NR\_nY**                      Bypass the noise reduction of record path for port n  
**1**                      Bypass  
**0**                      Do not bypass

**BP\_NR\_nS**                      Bypass the noise reduction of SPOT path for port n  
**1**                      Bypass  
**0**                      Do not bypass

Address	[7]	[6]	[5]	[4]	[3]	[2]	[1]	[0]
0x350	NR2_SML_THD	NR2_FR2	NR2_FR1	NR2_FR0	NR1_SML_THD	NR1_FR2	NR1_FR1	NR1_FR0
0x351	NR4_SML_THD	NR4_FR2	NR4_FR1	NR4_FR0	NR3_SML_THD	NR3_FR2	NR3_FR1	NR3_FR0

**NRn\_FR0**                      Force port n noise reduction to level 0 – Disable noise reduction

**NRn\_FR1**                      Force port n noise reduction to level 1 – weak

**NRn\_FR2**                      Force port n noise reduction to level 2 – strong

**NRn\_SML\_THD**                  Default 0

Address	[7]	[6]	[5]	[4]	[3]	[2]	[1]	[0]
0x352	0	0	0	0	NR4_RST_DET	NR3_RST_DET	NR2_RST_DET	NR1_RST_DET

**NRn\_RST\_DET**                  Reset the noise reduction detection for port n

Address	[7]	[6]	[5]	[4]	[3]	[2]	[1]	[0]
0x356	NR_DET_OUT_THD							NR_DET_REF_VAR

**NR\_DET\_OUT\_THD**              Default 6

**NR\_DET\_REF\_VAR**              Default 1

Address	[7]	[6]	[5]	[4]	[3]	[2]	[1]	[0]
0x357	NR_DET_NOISE_1L							
0x358	NR_DET_NOISE_1H							
0x359	NR_DET_NOISE_2L							
0x35A	NR_DET_NOISE_2H							
0x35B	NR_DET_NOISE_CL							
0x35C	NR_DET_NOISE_CH							
0x35D	NR_DET_SKIP_L							
0x35E	NR_DET_SKIP_H							

NR_DET_NOISE_1L	Lower bound of pixel distance for noise level 1 Default: 3
NR_DET_NOISE_1H	Higher bound of pixel distance for noise level 1 Default: 10
NR_DET_NOISE_2L	Lower bound of pixel distance for noise level 2 Default: 5
NR_DET_NOISE_2H	Higher bound of pixel distance for noise level 2 Default: 15
NR_DET_NOISE_CL	Lower bound of pixel distance for chroma noise level Default: 4
NR_DET_NOISE_CH	Higher bound of pixel distance for chroma noise level Default: 10
NR_DET_SKIP_L	Pixels with value below this threshold will not be processed Default: 25
NR_DET_SKIP_H	Pixels with value above this threshold will not be processed Default: 240

Address	[7]	[6]	[5]	[4]	[3]	[2]	[1]	[0]
0x35F	NRDET4_LVL*		NRDET3_LVL*		NRDET2_LVL*		NRDET1_LVL*	

\*Read only

NRDEtn_LVL	Detected noise level for channel n
0	Disable noise
1	Weak noise reduction
2	Strong noise reduction

**DOWNSCALER**

Address	[7]	[6]	[5]	[4]	[3]	[2]	[1]	[0]
0x301	0	BP_SCL_2S	BP_SCL_2Y	BP_SCL_2X	0	BP_SCL_1S	BP_SCL_1Y	BP_SCL_1X
0x302	0	BP_SCL_4S	BP_SCL_4Y	BP_SCL_4X	0	BP_SCL_3S	BP_SCL_3Y	BP_SCL_3X

**BP\_SCL\_nX**                      Bypass the down scaler of display path for port n  
**1**                      Bypass  
**0**                      Do not bypass

**BP\_SCL\_nY**                      Bypass the down scaler of record path for port n  
**1**                      Bypass  
**0**                      Do not bypass

**BP\_SCL\_nS**                      Bypass the down scaler of SPOT path for port n  
**1**                      Bypass  
**0**                      Do not bypass

Address	[7]	[6]	[5]	[4]	[3]	[2]	[1]	[0]
0x380								HSCL_DISP_TARG_1
0x390								HSCL_DISP_TARG_2
0x3A0								HSCL_DISP_TARG_3
0x3B0								HSCL_DISP_TARG_4

**HSCL\_DISP\_TARG\_n**      The display down scaler target horizontal size for port n.      The unit is in multiple of 16 pixels

Address	[7]	[6]	[5]	[4]	[3]	[2]	[1]	[0]
0x381								VSCL_DISP_TARG_1
0x391								VSCL_DISP_TARG_2
0x3A1								VSCL_DISP_TARG_3
0x3B1								VSCL_DISP_TARG_4

**VSCL\_DISP\_TARG\_n**      The display down scaler target vertical size for port n. The unit is in multiple of 8 lines

Address	[7]	[6]	[5]	[4]	[3]	[2]	[1]	[0]
0x382								HSCL_REC_TARG_1
0x392								HSCL_REC_TARG_2
0x3A2								HSCL_REC_TARG_3
0x3B2								HSCL_REC_TARG_4

**HSCL\_REC\_TARG\_n**      The record down scaler target horizontal size for port n.      The unit is in multiple of 16 pixels

Address	[7]	[6]	[5]	[4]	[3]	[2]	[1]	[0]
0x383								VSCL_REC_TARG_1
0x393								VSCL_REC_TARG_2
0x3A3								VSCL_REC_TARG_3
0x3B3								VSCL_REC_TARG_4

**VSCL\_REC\_TARG\_n** The record down scaler target vertical size for port n. The unit is in multiple of 8 lines

Address	[7]	[6]	[5]	[4]	[3]	[2]	[1]	[0]
0x384								HSCL_SPOT_TARG_1
0x394								HSCL_SPOT_TARG_2
0x3A4								HSCL_SPOT_TARG_3
0x3B4								HSCL_SPOT_TARG_4

**HSCL\_SPOT\_TARG\_n** The SPOT down scaler target horizontal size for port n. The unit is in multiple of 16 pixels

Address	[7]	[6]	[5]	[4]	[3]	[2]	[1]	[0]
0x385								VSCL_SPOT_TARG_1
0x395								VSCL_SPOT_TARG_2
0x3A5								VSCL_SPOT_TARG_3
0x3B5								VSCL_SPOT_TARG_4

**VSCL\_SPOT\_TARG\_n** The SPOT down scaler target vertical size for port n. The unit is in multiple of 8 lines

Address	[7]	[6]	[5]	[4]	[3]	[2]	[1]	[0]
0x387								HSCL_DISP_SRC_1
0x397								HSCL_DISP_SRC_2
0x3A7								HSCL_DISP_SRC_3
0x3B7								HSCL_DISP_SRC_4

**HSCL\_DISP\_SRC\_n** The display down scaler source horizontal size for port n. The unit is in multiple of 16 pixels

Address	[7]	[6]	[5]	[4]	[3]	[2]	[1]	[0]
0x388								VSCL_DISP_SRC_1
0x398								VSCL_DISP_SRC_2
0x3A8								VSCL_DISP_SRC_3
0x3B8								VSCL_DISP_SRC_4

**VSCL\_DISP\_SRC\_n** The display down scaler source vertical size for port n. The unit is in multiple of 8 lines



Address	[7]	[6]	[5]	[4]	[3]	[2]	[1]	[0]
0x389								HSCL_REC_SRC_1
0x399								HSCL_REC_SRC_2
0x3A9								HSCL_REC_SRC_3
0x3B9								HSCL_REC_SRC_4

**HSCL\_REC\_SRC\_n**      The record down scaler source horizontal size for port n. The unit is in multiple of 16 pixels

Address	[7]	[6]	[5]	[4]	[3]	[2]	[1]	[0]
0x38A								VSCL_REC_SRC_1
0x39A								VSCL_REC_SRC_2
0x3AA								VSCL_REC_SRC_3
0x3BA								VSCL_REC_SRC_4

**VSCL\_REC\_SRC\_n**      The record down scaler source vertical size for port n. The unit is in multiple of 8 lines

Address	[7]	[6]	[5]	[4]	[3]	[2]	[1]	[0]
0x38B								HSCL_SPOT_SRC_1
0x39B								HSCL_SPOT_SRC_2
0x3AB								HSCL_SPOT_SRC_3
0x3BB								HSCL_SPOT_SRC_4

**HSCL\_SPOT\_SRC\_n**      The SPOT down scaler source horizontal size for port n. The unit is in multiple of 16 pixels

Address	[7]	[6]	[5]	[4]	[3]	[2]	[1]	[0]
0x38C								VSCL_SPOT_SRC_1
0x39C								VSCL_SPOT_SRC_2
0x3AC								VSCL_SPOT_SRC_3
0x3BC								VSCL_SPOT_SRC_4

**VSCL\_SPOT\_SRC\_n**      The SPOT down scaler source vertical size for port n. The unit is in multiple of 8 lines

Address	[7]	[6]	[5]	[4]	[3]	[2]	[1]	[0]
0x386						FLDPOL_1S	FLDPOL_1Y	FLDPOL_1X
0x396						FLDPOL_2S	FLDPOL_2Y	FLDPOL_2X
0x3A6						FLDPOL_3S	FLDPOL_3Y	FLDPOL_3X
0x3B6						FLDPOL_4S	FLDPOL_4Y	FLDPOL_4X

**FLDPOL\_nX**      The display downscaler field polarity control for port n

**FLDPOL\_nY**      The record downscaler field polarity control for port n

**FLDPOL\_nS**      The SPOT downscaler field polarity control for port n

**MOTION / BLIND / NIGHT DETECTION**

Address	[7]	[6]	[5]	[4]	[3]	[2]	[1]	[0]
0x616	MD3_MASK_SEL		MD2_MASK_SEL		MD1_MASK_SEL		MD0_MASK_SEL	

**MDn\_MASK\_SEL**

Decide the read out of MD\_MASKS in 0x690 ~ 0x6EF

- 0 Read the detected motion of port n VINA
- 1 Read the detected motion of port n VINB
- 2 Read the mask of port n VINA
- 3 Read the mask of port n VINB

MDn\_MASK\_SEL also decide the write MD\_MASKS in 0x690 ~ 0x6EF

- 0 Write the mask for port n VINA
- 1 Write the mask for port n VINB

Address	[7]	[6]	[5]	[4]	[3]	[2]	[1]	[0]
0x617	MD_BASE_ADDR[4:0]							
0x618					MD_BASE_ADDR[8:5]			

**MD\_BASE\_ADDR**

The base address of the motion detection buffer. This address is in unit of 64K bytes. The generated DDR address will be {MD\_BASE\_ADDR, 16'h0000}. The default value should be 9'h0CF

Address	[7]	[6]	[5]	[4]	[3]	[2]	[1]	[0]
0x619							MD_PALNT	MD_TEST_EN

**MD\_PALNT**

Same as video decoder PALNT, need to be pull from bit 0 of 0x000, 0x010, 0x020, and 0x030 (To be fixed)

**MD\_TEST\_EN**

Enable test pattern (not implemented)

Address	[7]	[6]	[5]	[4]	[3]	[2]	[1]	[0]
0x61A			MD_DIS	MD_DUAL_EN	MD_STRB	MD_STRB_EN	BD_CELLSSENS	
0x61B	MD_TMPSENS				MD_PIXEL_OS			
0x61C	MD_REFFLD	MD_FIELD		MD_LVSENS				
0x61D	MD_CELSENS		MD_SPEED					
0x61E	MD_SPSSENS				BD_LVSENS			
0x61F	ND_TMPSENS				ND_LVSENS			

Register 0x61A ~ 0x61F are used to control the motion detection of 8 inputs (A / B inputs of 4 video decoders). In order to select the specific input to control, set the corresponding bit of MDCH\_SEL in 0x676.

<b>MD_DIS</b>	Disable the motion and blind detection. 0 Enable motion and blind detection (default) 1 Disable motion and blind detection
<b>MD_DUAL_EN</b>	Enable pseudo 8 channel for motion detection
<b>MD_STRB</b>	Request to start motion detection on manual trigger mode 0 None Operation (default) 1 Request to start motion detection
<b>MD_STRB_EN</b>	Select the trigger mode of motion detection 0 Automatic trigger mode of motion detection (default) 1 Manual trigger mode for motion detection
<b>BD_CELSENS</b>	Define the threshold of cell for blind detection. 0 Low threshold (More sensitive) (default) : 3 High threshold (Less sensitive)
<b>MD_TMPSENS</b>	Control the temporal sensitivity of motion detector. 0 More Sensitive (default) : 15 Less Sensitive
<b>MD_PIXEL_OS</b>	Adjust the horizontal starting position for motion detection 0 0 pixel (default) : 15 15 pixels
<b>MD_REFFLD</b>	Control the updating time of reference field for motion detection. 0 Update reference field every field (default) 1 Update reference field according to MD_SPEED
<b>MD_FIELD</b>	Select the field for motion detection. 0 Detecting motion for only odd field (default) 1 Detecting motion for only even field 2 Detecting motion for any field 3 Detecting motion for both odd and even field
<b>MD_LVSENS</b>	Control the level sensitivity of motion detector. 0 More sensitive (default) : 31 Less sensitive
<b>MD_CELSENS</b>	Define the threshold of sub-cell number for motion detection.

	0	Motion is detected if 1 sub-cell has motion (More sensitive) (default)
	1	Motion is detected if 2 sub-cells have motion
	2	Motion is detected if 3 sub-cells have motion
	3	Motion is detected if 4 sub-cells have motion (Less sensitive)
<b>MD_SPEED</b>		Control the velocity of motion detector. Large value is suitable for slow motion detection. In MD_DUAL_EN = 1, MD_SPEED should be limited to 0 ~ 31.
	0	1 field intervals (default)
	1	2 field intervals
	:	:
	61	62 field intervals
	62	63 field intervals
	63	Not supported
<b>MD_SPSENS</b>		Control the spatial sensitivity of motion detector.
	0	More Sensitive (default)
	:	:
	15	Less Sensitive
<b>BD_LVSENS</b>		Define the threshold of level for blind detection.
	0	Low threshold (More sensitive) (default)
	:	:
	15	High threshold (Less sensitive)
<b>ND_TMPSENS</b>		Define the threshold of temporal sensitivity for night detection.
	0	Low threshold (More sensitive) (default)
	:	:
	15	High threshold (Less sensitive)
<b>ND_LVSENS</b>		Define the threshold of level for night detection.
	0	Low threshold (More sensitive) (default)
	:	:
	15	High threshold (Less sensitive)

Registers 0x690 ~ 0x6EF are used to control the motion detection mask of input A / B of each video decoder. To access the corresponding inputs, set the corresponding MDn\_MASK\_SEL in 0x616.

Address	[7]	[6]	[5]	[4]	[3]	[2]	[1]	[0]
0x690								MDO_MASK0[7:0]
0x691								MDO_MASK0[15:8]
0x692								MDO_MASK1[7:0]
0x693								MDO_MASK1[15:8]
0x694								MDO_MASK2[7:0]
0x695								MDO_MASK2[15:8]
0x696								MDO_MASK3[7:0]
0x697								MDO_MASK3[15:8]
0x698								MDO_MASK4[7:0]
0x699								MDO_MASK4[15:8]
0x69A								MDO_MASK5[7:0]
0x69B								MDO_MASK5[15:8]
0x69C								MDO_MASK6[7:0]
0x69D								MDO_MASK6[15:8]
0x69E								MDO_MASK7[7:0]
0x69F								MDO_MASK7[15:8]
0x6A0								MDO_MASK8[7:0]
0x6A1								MDO_MASK8[15:8]
0x6A2								MDO_MASK9[7:0]
0x6A3								MDO_MASK9[15:8]
0x6A4								MDO_MASK10[7:0]
0x6A5								MDO_MASK10[15:8]
0x6A6								MDO_MASK11[7:0]
0x6A7								MDO_MASK11[15:8]

Address	[7]	[6]	[5]	[4]	[3]	[2]	[1]	[0]
0x6A8								MD1_MASK0[7:0]
0x6A9								MD1_MASK0[15:8]
0x6AA								MD1_MASK1[7:0]
0x6AB								MD1_MASK1[15:8]
0x6AC								MD1_MASK2[7:0]
0x6AD								MD1_MASK2[15:8]
0x6AE								MD1_MASK3[7:0]
0x6AF								MD1_MASK3[15:8]
0x6B0								MD1_MASK4[7:0]
0x6B1								MD1_MASK4[15:8]
0x6B2								MD1_MASK5[7:0]
0x6B3								MD1_MASK5[15:8]
0x6B4								MD1_MASK6[7:0]
0x6B5								MD1_MASK6[15:8]
0x6B6								MD1_MASK7[7:0]
0x6B7								MD1_MASK7[15:8]
0x6B8								MD1_MASK8[7:0]
0x6B9								MD1_MASK8[15:8]
0x6BA								MD1_MASK9[7:0]
0x6BB								MD1_MASK9[15:8]
0x6BC								MD1_MASK10[7:0]
0x6BD								MD1_MASK10[15:8]
0x6BE								MD1_MASK11[7:0]

Address	[7]	[6]	[5]	[4]	[3]	[2]	[1]	[0]
0x6BF	MD1_MASK11[15:8]							

Address	[7]	[6]	[5]	[4]	[3]	[2]	[1]	[0]
0x6C0	MD2_MASK0[7:0]							
0x6C1	MD2_MASK0[15:8]							
0x6C2	MD2_MASK1[7:0]							
0x6C3	MD2_MASK1[15:8]							
0x6C4	MD2_MASK2[7:0]							
0x6C5	MD2_MASK2[15:8]							
0x6C6	MD2_MASK3[7:0]							
0x6C7	MD2_MASK3[15:8]							
0x6C8	MD2_MASK4[7:0]							
0x6C9	MD2_MASK4[15:8]							
0x6CA	MD2_MASK5[7:0]							
0x6CB	MD2_MASK5[15:8]							
0x6CC	MD2_MASK6[7:0]							
0x6CD	MD2_MASK6[15:8]							
0x6CE	MD2_MASK7[7:0]							
0x6CF	MD2_MASK7[15:8]							
0x6D0	MD2_MASK8[7:0]							
0x6D1	MD2_MASK8[15:8]							
0x6D2	MD2_MASK9[7:0]							
0x6D3	MD2_MASK9[15:8]							
0x6D4	MD2_MASK10[7:0]							
0x6D5	MD2_MASK10[15:8]							
0x6D6	MD2_MASK11[7:0]							
0x6D7	MD2_MASK11[15:8]							

Address	[7]	[6]	[5]	[4]	[3]	[2]	[1]	[0]
0x6D8	MD3_MASK0[7:0]							
0x6D9	MD3_MASK0[15:8]							
0x6DA	MD3_MASK1[7:0]							
0x6DB	MD3_MASK1[15:8]							
0x6DC	MD3_MASK2[7:0]							
0x6DD	MD3_MASK2[15:8]							
0x6DE	MD3_MASK3[7:0]							
0x6DF	MD3_MASK3[15:8]							
0x6E0	MD3_MASK4[7:0]							
0x6E1	MD3_MASK4[15:8]							
0x6E2	MD3_MASK5[7:0]							
0x6E3	MD3_MASK5[15:8]							
0x6E4	MD3_MASK6[7:0]							
0x6E5	MD3_MASK6[15:8]							
0x6E6	MD3_MASK7[7:0]							
0x6E7	MD3_MASK7[15:8]							
0x6E8	MD3_MASK8[7:0]							
0x6E9	MD3_MASK8[15:8]							
0x6EA	MD3_MASK9[7:0]							
0x6EB	MD3_MASK9[15:8]							
0x6EC	MD3_MASK10[7:0]							

Address	[7]	[6]	[5]	[4]	[3]	[2]	[1]	[0]
0x6ED	MD3_MASK10[15:8]							
0x6EE	MD3_MASK11[7:0]							
0x6EF	MD3_MASK11[15:8]							

**MDx\_MASK** Define the motion Mask/Detection cell for VIN x. MD\_MASK[15] is right end and MD\_MASK[0] is left end of column.

In writing mode

- 0 Non-masking cell for motion detection (default)
- 1 Masking cell for motion detection

In reading mode when MDn\_MASK\_SEL = "0"

- 0 Motion is not detected for cell
- 1 Motion is detected for cell

In reading mode when MDn\_MASK\_SEL = "1"

- 0 Non-masked cell
- 1 Masked cell

Address	[7]	[6]	[5]	[4]	[3]	[2]	[1]	[0]
0x6F0	MD_STRB_DET*							

\*Read only bit

**MD\_STRBn**                    1 MD strobe has been performed at channel n  
                                       0 MD strobe has not yet been performed at channel n

Address	[7]	[6]	[5]	[4]	[3]	[2]	[1]	[0]
0x6F1	NOVID_DET_0B*	MD_DET_0B*	BD_DET_0B*	ND_DET_0B*	NOVID_DET_0A*	MD_DET_0A*	BD_DET_0A*	ND_DET_0A*
0x6F2	NOVID_DET_1B*	MD_DET_1B*	BD_DET_1B*	ND_DET_1B*	NOVID_DET_1A*	MD_DET_1A*	BD_DET_1A*	ND_DET_1A*
0x6F3	NOVID_DET_2B*	MD_DET_2B*	BD_DET_2B*	ND_DET_2B*	NOVID_DET_2A*	MD_DET_2A*	BD_DET_2A*	ND_DET_2A*
0x6F4	NOVID_DET_3B*	MD_DET_3B*	BD_DET_3B*	ND_DET_3B*	NOVID_DET_3A*	MD_DET_3A*	BD_DET_3A*	ND_DET_3A*

\*Read only bits

**NOVID\_DET\_mA**                NO\_VIDEO Detected from port m, analog path A (read only)

**NOVID\_DET\_mB**                NO\_VIDEO Detected from port m, analog path B (read only)

**MD\_DET\_mA**                    Motion Detected from port m, analog path A (read only)

**MD\_DET\_mB**                    Motion Detected from port m, analog path B (read only)

**BD\_DET\_mA**                    Blind Detected from port m, analog path A (read only)

**BD\_DET\_mB**                    Blind Detected from port m, analog path B (read only)

**ND\_DET\_mA**                    Night Detected from port m, analog path A (read only)

**ND\_DET\_mB**                    Night Detected from port m, analog path B

## Digital Input Interface

### 656 / 601 / RGB PORT

Address	[7]	[6]	[5]	[4]	[3]	[2]	[1]	[0]
---------	-----	-----	-----	-----	-----	-----	-----	-----

0x100	0	0	LIM_PB_656	656_PB_EC_BYPASS	PB_CH_NO_VIDEO*
-------	---	---	------------	------------------	-----------------

\* Read only

**LIM\_PB\_656** Specify the Clamping mode for PB input data at BT 656 mode  
**1** maximum 235, minimum 16  
**0** maximum 254, minimum 1

**656\_PB\_EC\_BYPASS** Bypass the error correction of BT 656  
**1** Bypass error correction  
**0** Do not bypass error correction when the parity check is wrong

**PB\_CH\_NO\_VIDEO[n]** NO\_VIDEO Status of Playback channel n (Read Only)

Address	[7]	[6]	[5]	[4]	[3]	[2]	[1]	[0]
0x101	PB_PORT_SEL3*		PB_PORT_SEL2*		PB_PORT_SEL1*		PB_PORT_SEL0*	

\* Read only

**PB\_PORT\_SELn** The playback channel n mux selection of the physical playback input port number (read only)  
**0** Channel n has input from Playback port 0  
**1** Channel n has input from Playback port 1  
**2** Channel n has input from Playback port 2  
**3** Channel n has input from Playback port 3



Address	[7]	[6]	[5]	[4]	[3]	[2]	[1]	[0]
0x102	PB1_VS_POL	PB1_HS_POL	PB1_TYPE	PBO_WIDTH	PBO_VS_POL	PBO_HS_POL	PBO_TYPE	

PB1_VS_POL	Playback Port 1 VSYNC signal polarity control 1 Reverse the polarity 0 Do not reverse the polarity
PB1_HS_POL	Playback Port 1 HSYNC signal polarity control 1 Reverse the polarity 0 Do not reverse the polarity
PB1_TYPE	Playback Port Type Control 1 – Refer to Table 3 for PB1_TYPE setting associated with PBO_TYPE 0 BT 656 mode 1 BT 601 mode
PBO_WIDTH	Playback Port 0 Data Width when used as component input mode (PBO_TYPE == 2'b11) 1 24 bits (R/V at PB2[7:0], G/Y at PB1[7:0], B/V at PB0[7:0]) 0 16 bit mode (R/V at {PB1[1:0], PBO[7:5]}, G/Y at PB1[7:2], B/V at PBO[4:0])
PBO_VS_POL	Playback Port 0 VSYNC signal polarity control 1 Reverse the polarity 0 Do not reverse the polarity
PBO_HS_POL	Playback Port 0 HSYNC signal polarity control 1 Reverse the polarity 0 Do not reverse the polarity
PBO_TYPE	Playback Port Type Control 0 – Refer to Table 3 for PBO_TYPE setting associated with PB1_TYPE 0 BT 656 1 BT 601 2 BT 1120 3 Component (RGB/YUV) input

Address	[7]	[6]	[5]	[4]	[3]	[2]	[1]	[0]
0x103	PB0_PROG	PB0_RGB	PB_FLD_DET_MD		PB_FLD_POL			

<b>PB0_PROG</b>	<b>Port PB0 input Progressive</b>
1	Port PB0 input is forced to progressive
0	Port PB0 input is interlaced
<b>PB0_RGB</b>	<b>Input is in RGB format</b>
1	Input is in RGB format
0	Input is in YUV format
<b>PB_FLD_DET_MODE[m]</b>	<b>LD Detection Mode when input port is 601 format for Port m</b>
1	Field ID is derived by sample the HSYNC signal at the leading edge of VSYNC
0	Field ID is derived by checking the distance between the leading edge of HSYNC and VSYNC. If the distance is larger than the VS_HS_LAG_TH specified in register 0x104 or 0x105, then this video field is an odd field. Otherwise it is even field.
<b>PB_FLD_POL[m]</b>	<b>Field Polarity Control for port m</b>
1	Reverse the input field polarity
0	Do not reverse the input field polarity

Address	[7]	[6]	[5]	[4]	[3]	[2]	[1]	[0]
0x104	PB0_VS_HS_LAG_TH							
0x105	PB1_VS_HS_LAG_TH							

<b>PB_VS_HS_LAG_TH</b>	<b>Use the VS to HS distance to determine the field ID. When this distance is larger than this threshold, it is odd field (field ID = 1'b0). Else it is even field (field ID = 1'b1). Used 8'hFF when PB_FLD_DET_MODE in 0x103 is set to 0.</b>
------------------------	---

Address	[7]	[6]	[5]	[4]	[3]	[2]	[1]	[0]
0x106	PB0_HA_ST[7:0]							
0x107	PB0_HA_LENGTH[7:0]							
0x108	0	PB0_HA_LENGTH[10:8]			0	PB0_HA_ST[10:8]		

<b>PB0_HA_ST</b>	<b>Specify the starting pixel of each line if PB port 0 is in BT 601 mode</b>
<b>PB0_HA_LEN</b>	<b>Specify the horizontal active length if PB port 0 is in BT 601 mode</b>

Address	[7]	[6]	[5]	[4]	[3]	[2]	[1]	[0]
0x109	PBO_VA1_ST[7:0]							
0x10A	PBO_VA2_ST[7:0]							
0x10B	PBO_VA_LEN[7:0]							
0x10C	0	0	PBO_VA_LEN[9:8]		PBO_VA2_ST[9:8]		PBO_VA1_ST[9:8]	

**PBO\_VAx\_ST** Specify the starting line if PB port 0 is in BT 601 mode  
**PBO\_VA1\_ST:** The starting line of even field  
**PBO\_VA2\_ST:** The starting line of odd field

**PBO\_VA\_LEN** Specify the vertical active length if PB port 0 is in BT 601 mode

Address	[7]	[6]	[5]	[4]	[3]	[2]	[1]	[0]
0x10D	PB1_HA_ST[7:0]							
0x10E	PB1_HA_LEN[7:0]							
0x10F	0	PB1_HA_LEN[10:8]			0	PB1_HA_ST[10:8]		

**PB1\_HA\_ST** Specify the starting pixel of each line if PB port 1 is in BT 601 mode

**PB1\_HA\_LEN** Specify the horizontal active length if PB port 1 is in BT 601 mode

Address	[7]	[6]	[5]	[4]	[3]	[2]	[1]	[0]
0x110	PB1_VA1_ST[7:0]							
0x111	PB1_VA2_ST[7:0]							
0x112	PB1_VA_LEN[7:0]							
0x113	0	0	PB1_VA_LEN[9:8]		PB1_VA2_ST[9:8]		PB1_VA1_ST[9:8]	

**PB1\_VAx\_ST** Specify the starting line if PB port 1 is in BT 601 mode  
**PB1\_VA1\_ST:** The starting line of even field  
**PB1\_VA2\_ST:** The starting line of odd field

**PB1\_VA\_LEN** Specify the vertical active length if PB port1 is in BT 601 mode

**CHID DECODE / STROBE**

Address	[7]	[6]	[5]	[4]	[3]	[2]	[1]	[0]
0x120	PB0_MAN_STRB_EN				PB0_MAN_PIC_TYPE			
0x130	PB1_MAN_STRB_EN				PB1_MAN_PIC_TYPE			
0x140	PB2_MAN_STRB_EN				PB2_MAN_PIC_TYPE			
0x150	PB3_MAN_STRB_EN				PB3_MAN_PIC_TYPE			

**PBm\_MAN\_STRB\_EN** Enable manual strobe mode for PB port m  
**1** Enable  
**0** Disable

**PBm\_MAN\_PIC\_TYPE** Specify the picture type used in manual strobe mode for PB port m

Address	[7]	[6]	[5]	[4]	[3]	[2]	[1]	[0]
0x121	PB0_MAN_CH1_ID				PB0_MAN_CHO_ID			
0x122	PB0_MAN_CH3_ID				PB0_MAN_CH2_ID			
0x131	PB1_MAN_CH1_ID				PB1_MAN_CHO_ID			
0x132	PB1_MAN_CH3_ID				PB1_MAN_CH2_ID			
0x141	PB2_MAN_CH1_ID				PB2_MAN_CHO_ID			
0x142	PB2_MAN_CH3_ID				PB2_MAN_CH2_ID			
0x151	PB3_MAN_CH1_ID				PB3_MAN_CHO_ID			
0x152	PB3_MAN_CH3_ID				PB3_MAN_CH2_ID			

**PBm\_MAN\_CHn\_ID** Specify the channel ID to be used at PB port m channel n in Manual Strobe mode

**PBm\_MAN\_CHn\_ID[3:2]** chip ID  
**PBm\_MAN\_CHn\_ID[1:0]** channel ID

Address	[7]	[6]	[5]	[4]	[3]	[2]	[1]	[0]
0x123	0	PB0_AUTO_STRB_EN	PB0_FORCE_LIVE	PB0_MAN_STRB_FLD	PB0_MAN_ANA			
0x133	0	PB1_AUTO_STRB_EN	PB1_FORCE_LIVE	PB1_MAN_STRB_FLD	PB1_MAN_ANA			
0x143	0		PB2_FORCE_LIVE	PB2_MAN_STRB_FLD	PB2_MAN_ANA			
0x153	0		PB3_FORCE_LIVE	PB3_MAN_STRB_FLD	PB3_MAN_ANA			

**PBm\_AUTO\_STRB\_EN**

Enable playback port m automatic strobe using the channel ID embedded in the VBI. Only PB0 and PB1 has channel ID decoder. PB2 and PB3 do not support audio CHID.

- 1 Enable to use the channel ID embedded in the VBI to strobe. In this mode, the Strobe signal is sent out automatically without CPU issuing a strobe signal.
- 0 Disable: Use the channel ID specified by the register 0x120 ~ 0x122, 0x130 ~ 0x132, 0x140 ~ 0x142, 0x150 ~ 0x152 to strobe.

**PBm\_FORCE\_LIVE**

Force the playback to strobe on whatever input video stream.

- 1 When this bit is set to 1, the strobe is always sent out. It will behave like a LIVE input. When this mode is on, the PBm\_MAN\_PIC\_TYPE has to be set to 0x01.
- 0 When this bit is set to 0, the strobe will be sent out only if there is a match if PB\_CHNUM with the channel ID from the VBI, or the channel ID specified in the registers in 0x120 ~ 0x122, 0x130 ~ 0x132, 0x140 ~ 0x142, 0x150 ~ 0x152.

Address	[7]	[6]	[5]	[4]	[3]	[2]	[1]	[0]
0x129	PB0_AUTO_STROBE_CH_EN			PB0_VACTIVE[9:8]		PB0_VDELAY[9:8]		
0x139	PB1_AUTO_STROBE_CH_EN			PB1_VACTIVE[9:8]		PB1_VDELAY[9:8]		
0x149				PB2_VACTIVE[9:8]		PB2_VDELAY[9:8]		
0x159				PB3_VACTIVE[9:8]		PB3_VDELAY[9:8]		

**PBn\_AUTO\_STROBE\_CH\_EN[m]**

Specify whether to turn on the auto strobe for port n, on channels m. Only PB0 and PB1 have channel ID decoder. PB2 and PB3 do not support audio CHID.

Address	[7]	[6]	[5]	[4]	[3]	[2]	[1]	[0]
0x12A	0	PB0_CHID_FLD_OS	PB0_DID_EN	PB0_AID_EN	PB0_FLT_EN	PB0_RIC_EN	PB0_AUTO_CHID_DET	
0x13A	0	PB1_CHID_FLD_OS	PB1_DID_EN	PB1_AID_EN	PB1_FLT_EN	PB1_RIC_EN	PB1_AUTO_CHID_DET	

<b>PBm_CHID_FLD_OS</b>	The PB port m CHID line offset of even field relative to odd field. <b>2</b> One line more than odd field <b>1</b> Same offset as odd field <b>0</b> One line less than odd field
<b>PBm_DID_EN</b>	Enable digital channel ID detection for the PB port m <b>1</b> Turn on digital channel ID decoding <b>0</b> Turn off digital channel ID decoding
<b>PBm_AID_EN</b>	Enable the Analog channel ID detection for PB port m <b>1</b> Turn on analog channel ID detection <b>0</b> Turn off analog channel ID detection
<b>PBm_RIC_EN</b>	Select the run-in clock mode for analog channel ID <b>1</b> Run-in clock mode <b>0</b> No run-in clock mode
<b>PBm_FLT_EN</b>	Select the LPF filter mode for playback input <b>0</b> Bypass mode <b>1</b> Enable the LPF filter
<b>PBm_AUTO_CHID_DET</b>	Select the detection mode of Analog channel ID for playback input port m <b>0</b> Manual detection mode for Analog channel ID <b>1</b> Automatic detection mode for Analog channel ID

Address	[7]	[6]	[5]	[4]	[3]	[2]	[1]	[0]
0x12B	PBO_CHID_LINE_SIZE			PBO_CHID_V_OFST				
0x13B	PB1_CHID_LINE_SIZE			PB1_CHID_V_OFST				

**PBm\_CHID\_LINE\_SIZE** Control the line width for Analog Channel ID for playback input port m in manual detection mode (PBm\_AUTO\_CHID\_DET = 0)

0 1 line  
 1 2 lines  
 :  
 7 8 lines (Default)

**PBm\_CHID\_V\_OFST** Control the vertical starting offset from field transition for analog channel ID

0 No offset  
 :  
 8 (default)  
 :  
 31

Address	[7]	[6]	[5]	[4]	[3]	[2]	[1]	[0]
0x12C	PBO_CHID_H_OFST							
0x13C	PB1_CHID_H_OFST							

**PBm\_CHID\_H\_OFST** Define the horizontal starting offset of analog channel ID in manual detection mode (PBm\_AUTO\_CHID\_DET = 0)

Address	[7]	[6]	[5]	[4]	[3]	[2]	[1]	[0]
0x12D	0	0	PBO_VAV_CHK	PBO_ANA_CHID_BW				
0x13D	0	0	PB1_VAV_CHK	PB1_ANA_CHID_BW				

**PBm\_VAV\_CHK** Enable the channel ID detection in vertical active period  
 0 Enable the channel ID detection for VBI period only (default)  
 1 Enable the channel ID detection for VBI and active period

**PBm\_ANA\_CHID\_BW** Define the pixel width for each bit of analog channel ID

0 1 pixel  
 :  
 31 32 pixels

Address	[7]	[6]	[5]	[4]	[3]	[2]	[1]	[0]
0x12E	PB0_CHID_MID_VAL							
0x13E	PB1_CHID_MID_VAL							

**PBm\_CHID\_MID\_VAL** Define the slicer threshold level to detect bit “0” or bit “1” from analog channel ID (default 128)

Address	[7]	[6]	[5]	[4]	[3]	[2]	[1]	[0]
0x15F	0	0	0	0	0	0	PB_NOVID_MD	

**PB\_NOVID\_MD** Select the No-Video flag generation mode

- 0 Faster
- 1 Fast
- 2 Slow
- 3 Slower (default)

Address	[7]	[6]	[5]	[4]	[3]	[2]	[1]	[0]
0x160	0	PB_STOP0	PB_HSCL_BYPO	PB_ANAO	PB_CHNUM0			
0x170	0	PB_STOP1	PB_HSCL_BYP1	PB_ANA1	PB_CHNUM1			
0x180	0	0	PB_HSCL_BYP2	PB_ANA2	PB_CHNUM2			
0x190	0	0	PB_HSCL_BYP3	PB_ANA3	PB_CHNUM3			

**PB\_STOPn** Disable the auto strobe operation for playback channel n

- 0 Normal Operation (default)
- 1 Stop the auto strobe operation for playback channel n

**PB\_HSCL\_BYPn** Bypass the horizontal scaler for playback channel n

- 0 Normal operation
- 1 Bypass the horizontal scaler

**PB\_ANAn** The analog input selection of channel n

- 0 Select VINA
- 1 Select VINB

**PB\_CHNUMn** The playback channel ID selection

- PB\_CHNUMn[3:2] CHIP ID
- PB\_CHNUMn[1:0] Port ID

Address	[7]	[6]	[5]	[4]	[3]	[2]	[1]	[0]
0x161							PB_2X_EN0	PB_FLD_POL0
0x171							PB_2X_EN1	PB_FLD_POL1
0x181							PB_2X_EN2	PB_FLD_POL2
0x191							PB_2X_EN3	PB_FLD_POL3

**PB\_2X\_ENn** Scale up 2X horizontally for PB channel n

**PB\_FLD\_POLn** Reverse the field signal polarity of channel n



Address	[7]	[6]	[5]	[4]	[3]	[2]	[1]	[0]
0x1A0	PB_STATUS_PORT_SEL		PB_STATUS_TYPE_SEL			PB_STATUS_MOTION_INDEX		

**PB\_STATUS\_PORT\_SEL**

Select the port number from which the status is read back at register 0x1A2 through 0x1AF

00 PB port 0  
 01 PB port 1  
 1X Reserved

**PB\_STATUS\_TYPE\_SEL**

Select the channel ID type of the status read back at register 0x1A8 through 0x1AF

000 Auto CHID  
 001 Detection CHID  
 010 User CHID  
 100 Motion ID 0  
 101 Motion ID 1  
 110 Motion ID 2  
 111 Motion ID 3

**PB\_STATUS\_MOTION\_INDEX**

Select the bit index range of playback motion channel ID read back at 0x1A8 Through 0x1AF

000 Motion ID bit [63:0]  
 001 Motion ID bit [127:64]  
 010 Motion ID bit [191:128]

Address	[7]	[6]	[5]	[4]	[3]	[2]	[1]	[0]
0x1A1					PB_CH3_AUTO_VLD*	PB_CH2_AUTO_VLD*	PB_CH1_AUTO_VLD*	PB_CH0_AUTO_VLD*

**PB\_CHn\_AUTO\_VLD** Playback Channel n auto channel ID valid status (read only)

Address	[7]	[6]	[5]	[4]	[3]	[2]	[1]	[0]
0x1A2	DET_CHID_VLD*		USR_CHID_VLD*		MOTION_CHID_VLD*			

**DET\_CHID\_VLD** The detection channel ID valid status of port m, where m is selected by PB\_STATUS\_PORT\_SEL in 0x1A0 (read only)

**USER\_CHID\_VLD** The user channel ID valid status of port m, where m is selected By PB\_STATUS\_PORT\_SEL in 0x1A0 (read only)

**MOTION\_CHID\_VLD** The motion channel ID valid status of port m, where m is selected by PB\_STATUS\_PORT\_SEL in 0x1A0 (read only)

Address	[7]	[6]	[5]	[4]	[3]	[2]	[1]	[0]
0x1A3	PB_CHID_LINE_SIZE_DET*				PB_ANA_CHID_BW_DET			

**PB\_CHID\_LINE\_SIZE\_DET**

The detected VBI line size of port m, where m is selected by PB\_STATUS\_PORT\_SEL in 0x1A0 (read only)

**PB\_ANA\_CHID\_BW\_DET**

The detected VBI pixel width of port m, where m is selected by PB\_STATUS\_PORT\_SEL in 0x1A0 (read only)

Address	[7]	[6]	[5]	[4]	[3]	[2]	[1]	[0]
0x1A4								PB_PIC_TYPE*

**PB\_PIC\_TYPE**

The detected VBI picture type of port m, where m is selected by PB\_STATUS\_PORT\_SEL in 0x1A0 (read only)

Address	[7]	[6]	[5]	[4]	[3]	[2]	[1]	[0]
0x1A5	0	0	0	0	PB_CHID_TYPE			

**PB\_CHID\_TYPE**

The detected VBI channel ID type of port m, where m is selected By PB\_STATUS\_PORT\_SEL in 0x1A0 (read only)

Address	[7]	[6]	[5]	[4]	[3]	[2]	[1]	[0]
0x1A8	CHID_STATUS0*							
0x1A9	CHID_STATUS1*							
0x1AA	CHID_STATUS2*							
0x1AB	CHID_STATUS3*							
0x1AC	CHID_STATUS4*							
0x1AD	CHID_STATUS5*							
0x1AE	CHID_STATUS6*							
0x1AF	CHID_STATUS7*							

This set of registers read back the channel ID detected in the VBI. These registers are all Read only. The PB\_STATUS\_PORT\_SEL will select the corresponding playback port status.

**PB\_STATUS\_TYPE\_SEL = 0**

CHID\_STATUS0: AUTO\_CHANNEL\_ID0  
 CHID\_STATUS1: AUTO\_CHANNEL\_ID1  
 CHID\_STATUS2: AUTO\_CHANNEL\_ID2  
 CHID\_STATUS3: AUTO\_CHANNEL\_ID3  
 CHID\_STATUS4: Bit 7:4: Vertical Location of Channel n  
 Bit 3:0: Horizontal Location of Channel n  
 CHID\_STATUS5: Bit 7:4: Playback strobe of Channel n  
 Bit 3:0: Playback analog path of Channel n  
 CHID\_STATUS6: Bit 7:4: Reserved  
 Bit 3:0: Field Mode of Channel n  
 CHID\_STATUS7: Reserved

**PB\_STATUS\_TYPE\_SEL = 1**

CHID\_STATUS0: DET\_CHANNEL\_ID[7:0] of Chip ID 0  
 CHID\_STATUS1: DET\_CHANNEL\_ID[15:8] of Chip ID 0  
 CHID\_STATUS2: DET\_CHANNEL\_ID[7:0] of Chip ID 1  
 CHID\_STATUS3: DET\_CHANNEL\_ID[15:8] of Chip ID 1  
 CHID\_STATUS4: DET\_CHANNEL\_ID[7:0] of Chip ID 2  
 CHID\_STATUS5: DET\_CHANNEL\_ID[15:8] of Chip ID 2  
 CHID\_STATUS6: DET\_CHANNEL\_ID[7:0] of Chip ID 3  
 CHID\_STATUS7: DET\_CHANNEL\_ID[15:8] of Chip ID 3

**PB\_STATUS\_TYPE\_SEL = 2**

CHID\_STATUS0: USER\_CHANNEL\_ID0[7:0]  
 CHID\_STATUS1: USER\_CHANNEL\_ID0[15:8]  
 CHID\_STATUS2: USER\_CHANNEL\_ID1[7:0]  
 CHID\_STATUS3: USER\_CHANNEL\_ID1[15:8]  
 CHID\_STATUS4: USER\_CHANNEL\_ID2[7:0]  
 CHID\_STATUS5: USER\_CHANNEL\_ID2[15:8]  
 CHID\_STATUS6: USER\_CHANNEL\_ID3[7:0]  
 CHID\_STATUS7: USER\_CHANNEL\_ID3[15:8]

**PB\_STATUS\_TYPE\_SEL = 4**

n is specified by PB\_STATUS\_MOTION\_INDEX  
 CHID\_STATUS0: MOTION\_CHANNEL\_ID0[64\*n+7:64\*n]  
 CHID\_STATUS1: MOTION\_CHANNEL\_ID0 [64\*n+15 : 64 \*n+8]  
 CHID\_STATUS2: MOTION\_CHANNEL\_ID0[64\*n+23 : 64 \*n+16]  
 CHID\_STATUS3: MOTION\_CHANNEL\_ID0[64\*n+31:64 \*n+24]  
 CHID\_STATUS4: MOTION\_CHANNEL\_ID0[64\*n+39:64 \*n+32]  
 CHID\_STATUS5: MOTION\_CHANNEL\_ID0[64\*n+47:64 \*n+40]  
 CHID\_STATUS6: MOTION\_CHANNEL\_ID0[64\*n+55:64 \*n+48]  
 CHID\_STATUS7: MOTION\_CHANNEL\_ID0[64\*n+63:64 \*n+56]

**PB\_STATUS\_TYPE\_SEL = 5**      n is specified by PB\_STATUS\_MOTION\_INDEX  
 CHID\_STATUS0: MOTION\_CHANNEL\_ID1[64\*n+7:64\*n],  
 CHID\_STATUS1: MOTION\_CHANNEL\_ID1[64\*n+15:64\*n+8]  
 CHID\_STATUS2: MOTION\_CHANNEL\_ID1[64\*n+23:64\*n+16]  
 CHID\_STATUS3: MOTION\_CHANNEL\_ID1[64\*n+31:64\*n+24]  
 CHID\_STATUS4: MOTION\_CHANNEL\_ID1[64\*n+39:64\*n+32]  
 CHID\_STATUS5: MOTION\_CHANNEL\_ID1[64\*n+47:64\*n+40]  
 CHID\_STATUS6: MOTION\_CHANNEL\_ID1[64\*n+55:64\*n+48]  
 CHID\_STATUS7: MOTION\_CHANNEL\_ID1[64\*n+63:64\*n+56]

**PB\_STATUS\_TYPE\_SEL = 6**      n is specified by PB\_STATUS\_MOTION\_INDEX  
 CHID\_STATUS0: MOTION\_CHANNEL\_ID2[64\*n+7:64\*n]  
 CHID\_STATUS1: MOTION\_CHANNEL\_ID2[64\*n+15:64\*n+8]  
 CHID\_STATUS2: MOTION\_CHANNEL\_ID2[64\*n+23:64\*n+16]  
 CHID\_STATUS3: MOTION\_CHANNEL\_ID2[64\*n+31:64\*n+24]  
 CHID\_STATUS4: MOTION\_CHANNEL\_ID2[64\*n+39:64\*n+32]  
 CHID\_STATUS5: MOTION\_CHANNEL\_ID2[64\*n+47:64\*n+40]  
 CHID\_STATUS6: MOTION\_CHANNEL\_ID2[64\*n+55:64\*n+48]  
 CHID\_STATUS7: MOTION\_CHANNEL\_ID2[64\*n+63:64\*n+56]

**PB\_STATUS\_TYPE\_SEL = 7**      n is specified by PB\_STATUS\_MOTION\_INDEX  
 CHID\_STATUS0: MOTION\_CHANNEL\_ID3[64\*n+7:64\*n],  
 CHID\_STATUS1: MOTION\_CHANNEL\_ID3[64\*n+15:64\*n+8]  
 CHID\_STATUS2: MOTION\_CHANNEL\_ID3[64\*n+23:64\*n+16]  
 CHID\_STATUS3: MOTION\_CHANNEL\_ID3[64\*n+31:64\*n+24]  
 CHID\_STATUS4: MOTION\_CHANNEL\_ID3[64\*n+39:64\*n+32]  
 CHID\_STATUS5: MOTION\_CHANNEL\_ID3[64\*n+47:64\*n+40]  
 CHID\_STATUS6: MOTION\_CHANNEL\_ID3[64\*n+55:64\*n+48]  
 CHID\_STATUS7: MOTION\_CHANNEL\_ID3[64\*n+63:64\*n+56]

## PLAYBACK CROPPING

Address	[7]	[6]	[5]	[4]	[3]	[2]	[1]	[0]
0x124	PBO_HDELAY[7:0]							
0x125	PBO_HACTIVE[7:0]							
0x126	0	PBO_HACTIVE[10:8]			0	PBO_HDELAY[10:8]		
0x134	PB1_HDELAY[7:0]							
0x135	PB1_HACTIVE[7:0]							
0x136	0	PB1_HACTIVE[10:8]			0	PB1_HDELAY[10:8]		
0x144	PB2_HDELAY[7:0]							
0x145	PB2_HACTIVE[7:0]							
0x146	0	PB2_HACTIVE[10:8]			0	PB2_HDELAY[10:8]		
0x154	PB3_HDELAY[7:0]							
0x155	PB3_HACTIVE[7:0]							
0x156	0	PB3_HACTIVE[10:8]			0	PB3_HDELAY[10:8]		

**PBn\_HDELAY**      Specify the starting pixel number for cropping port n. Pixels before this pixel number are cropped. Note that this is before the further cropping based on picture type.

**PBn\_HACTIVE**      Specify the active horizontal length for cropping port n. Pixels beyond the range of this horizontal length are cropped. Note that this is before the further cropping based on picture type.

Address	[7]	[6]	[5]	[4]	[3]	[2]	[1]	[0]
0x127	PBO_VDELAY[7:0]							
0x128	PBO_VACTIVE[7:0]							
0x129	PBO_AUTO_STROBE_CH_EN				PBO_VACTIVE[9:8]		PBO_VDELAY[9:8]	
0x137	PB1_VDELAY[7:0]							
0x138	PB1_VACTIVE[7:0]							
0x139	PB1_AUTO_STROBE_CH_EN				PB1_VACTIVE[9:8]		PB1_VDELAY[9:8]	
0x147	PB2_VDELAY[7:0]							
0x148	PB2_VACTIVE[7:0]							
0x149	PB2_AUTO_STROBE_CH_EN				PB2_VACTIVE[9:8]		PB2_VDELAY[9:8]	
0x157	PB3_VDELAY[7:0]							
0x158	PB3_VACTIVE[7:0]							
0x159	PB3_AUTO_STROBE_CH_EN				PB3_VACTIVE[9:8]		PB3_VDELAY[9:8]	

**PBn\_VDELAY** Specify the starting line number for cropping port n. Lines before this line number is cropped. Note that this is before the further cropping based on the picture type

**PBn\_VACTIVE** Specify the active vertical length cropping port n. Lines beyond the range of this vertical length are cropped. Note that this is before further cropping based on the picture type.

**PLAYBACK DOWNSCALERS**

Address	[7]	[6]	[5]	[4]	[3]	[2]	[1]	[0]
0x162	0	PB_SCALE_TARGET_HSIZE0						
0x163	0	0	PB_SCALE_TARGET_VSIZE0					
0x164	0	PB_SCALE_SRC_HSIZE0						
0x165	0	0	PB_SCALE_SRC_VSIZE0					
0x172	0	0	PB_SCALE_TARGET_HSIZE1					
0x173	0	0	PB_SCALE_TARGET_VSIZE1					
0x174	0	0	PB_SCALE_SRC_HSIZE1					
0x175	0	0	PB_SCALE_SRC_VSIZE1					
0x182	0	0	PB_SCALE_TARGET_HSIZE2					
0x183	0	0	PB_SCALE_TARGET_VSIZE2					
0x184	0	0	PB_SCALE_SRC_HSIZE2					
0x185	0	0	PB_SCALE_SRC_VSIZE2					
0x192	0	0	PB_SCALE_TARGET_HSIZE3					
0x193	0	0	PB_SCALE_TARGET_VSIZE3					
0x194	0	0	PB_SCALE_SRC_HSIZE3					
0x195	0	0	PB_SCALE_SRC_VSIZE3					

**PB\_SCALE\_TARGET\_HSIZE<sub>n</sub>**

Target horizontal size of channel n after scaling. The unit is 16 pixels.

**PB\_SCALE\_TARGET\_VSIZE<sub>n</sub>**

Target vertical size of channel n after scaling. The unit is 8 lines.

**PB\_SCALE\_SRC\_HSIZE<sub>n</sub>**

Source horizontal size of channel n before scaling. The unit is 16 pixels.

**PB\_SCALE\_SRC\_VSIZE<sub>n</sub>**

Source vertical size of channel n before scaling. The unit is 8 lines.

## Video Multiplexers

### RECORD CONTROL

Address	[7]	[6]	[5]	[4]	[3]	[2]	[1]	[0]
0x200	0	0	RP_INP_FLD_POL	RP_CC_EN		0	RP_CLK_SEL	

RP_INP_FLD_POL	Reverse the field polarity for record path only
RP_CC_EN[1]	1 Record Cascade Output Enable 0 Record Cascade Output Disable This feature is not available in TW2851 rev B2. This bit is always set to 0.
RP_CC_EN[0]	1 Record Cascade Input Enable 0 Record Cascade Input Disable This feature is not available in TW2851 rev B2. This bit is always set to 0.
RP_CLK_SEL	Record Path Clock Selection 0 Reserved 1 27 MHz for 1 port 656, 13.5 MHz for 2 port 656 or 601 2 54 MHz for 1 port 656, 27 MHz for 2 port 656 or 601 3 108 MHz for 1 port 656, 54 MHz for 2 port 656, 601, or 1120

Address	[7]	[6]	[5]	[4]	[3]	[2]	[1]	[0]
0x201	RP_BLANK_COLR		RP_BGND_COLR		0	RP_BLNK_DIS	0	0

RP_BLANK_COLR	The blank color of the video window that does not have active video source or forced to show the blank color 0 Dark Gray 1 Intermediate Gray 2 Bright Gray 3 Blue
RP_BGND_COLR	The background color outside of the video window configured picture. 0 Dark Gray 1 Intermediate Gray 2 Bright Gray 3 Blue
RP_BLNK_DIS	0 Shows blank color specified by RP_BLANK_COLR when NO_VIDEO signal is detected 1 shows the last image captured when the NO_VIDEO is detected

Address	[7]	[6]	[5]	[4]	[3]	[2]	[1]	[0]
0x202	0	RP_1120		RP_601	RP_2_656	RP_LIM_656		

RP\_1120                    1     Record Port output is in 1440x960 resolution  
                                  0     Record Port output is in format specified by PIC\_TYPE

RP\_601                     1     Record Port output is in 601 format  
                                  0     Record Port output is in 656 format

RP\_2\_656                 1     Record output in 656 format in 2 physical port  
                                  0     Record output in single port 656 or 601 format

RP\_LIM\_656              656 data value clamping selection for Y

RP\_LIM\_656[2]  
 1     Maximum is 235  
 0     Maximum is 254  
 RP\_LIM\_656[1:0]  
 0     Minimum is 1  
 1     Minimum is 16,  
 2     Minimum is 24  
 3     Minimum is 32

For C

RP\_LIM\_656  
 0~1   Maximum 254, Minimum 1  
 2 ~ 7   Maximum 240, Minimum 16

Note that the interface configuration changes should always be followed by a system reset in order to make the change effective.

Address	[7]	[6]	[5]	[4]	[3]	[2]	[1]	[0]
0x203	RP_H_OFFSET							
0x204	0	RP_V_OFFSET						
0x205	RP_H_SIZE[7:0]							
0x206	RP_V_SIZE[7:0]							
0x207	0	0	0	0	0	RP_V_SIZE[8]	RP_H_SIZE[9:8]	

RP\_H\_OFFSET              The horizontal offset of the first active pixel in the output 656/601 format

RP\_V\_OFFSET              The vertical offset of the first active line in the output 656/601 format

RP\_H\_SIZE                The horizontal active length used to show the video pictures

RP\_V\_SIZE                The vertical active height used to show the video pictures



Address	[7]	[6]	[5]	[4]	[3]	[2]	[1]	[0]
0x210	RP_CH_EN_0	0	RP_FUNC_MD_0	RP_ANA_0	0	RP_BLNK_0	RP_MIR_V_0	RP_MIR_H_0
0x211	RP_CH_EN_1	0	RP_FUNC_MD_1	RP_ANA_1	0	RP_BLNK_1	RP_MIR_V_1	RP_MIR_H_1
0x212	RP_CH_EN_2	0	RP_FUNC_MD_2	RP_ANA_2	0	RP_BLNK_2	RP_MIR_V_2	RP_MIR_H_2
0x213	RP_CH_EN_3	0	RP_FUNC_MD_3	RP_ANA_3	0	RP_BLNK_3	RP_MIR_V_3	RP_MIR_H_3

<b>RP_CH_EN</b>	Channel Enable Control for each of channel 0 through 3 <b>1</b> Enable channel <b>0</b> Disable channel
<b>RP_FUNC_MD</b>	When the Record Path is not in Switch mode, this bit specifies the record capture mode <b>1</b> Strobe Mode <b>0</b> Live Mode
<b>RP_ANA</b>	Specify the analog input selection of each of the channel. <b>0</b> VINA <b>1</b> VINB
<b>RP_BLNK</b>	Force the channel to display blank color <b>1</b> Blank <b>0</b> Normal video
<b>RP_MIR_V</b>	Control to mirror the image vertically for each channel <b>0</b> Do not mirror vertically <b>1</b> Mirror vertically
<b>RP_MIR_H</b>	Control to mirror the image horizontally for each channel <b>0</b> Do not mirror horizontally <b>1</b> Mirror horizontally

Address	[7]	[6]	[5]	[4]	[3]	[2]	[1]	[0]
0x214	0	0	0	0	RP_STROBE_3	RP_STROBE_2	RP_STROBE_1	RP_STROBE_0

<b>RP_STROBE</b>	Strobe command for each channel. Once set to <b>1</b> , the corresponding channel will capture one field/frame and then clear this bit.
------------------	---

Address	[7]	[6]	[5]	[4]	[3]	[2]	[1]	[0]
0x215	0	RP_STRB_FLD	RP_CH_CYCLE		RP_SM_EN	RP_PIC_TYPE		

RP_STRB_FLD	In non-switch mode, this bit controls which field to capture in field mode ( pic_type 0, 2, 4, 6, 7) 0 Capture Even field 1 Capture Odd field
RP_CH_CYCLE	In non-switch mode, this RP_CH_CYCLE controls how many channels to interleave when the pic_type is 0, 1, 6, and 7.  PIC_TYPE 0, 1 0 Capture and interleave channel 0, 1, 2, 3 1 Capture channel 0 2 Capture and interleave channel 0, 1 3 Capture and interleave channel 0, 1, 2  PIC_TYPE 6, 7 1 Capture channel 0, 1 2 Capture and interleave channel 0, 1, 2, 3
RP_SM_EN	1 Record Path is in Switch Queue Mode 0 Record Path is in Live or Strobe Mode
RP_PIC_TYPE	When Record Path is not in Switch Queue Mode, RP_PIC_TYPE specifies the pic_type used in LIVE/Strobe mode

## RECORD SWITCH QUEUE

Address	[7]	[6]	[5]	[4]	[3]	[2]	[1]	[0]
0x208	RP_SQ_CMD	RP_SQ_WR	RP_SQ_RW_DONE*	0	0	0	0	RP_CONFIG_DONE

RP_SQ_CMD	The command bit to start a Record Path Switch Queue read / write operation. Set to 1 to start a command. This bit will self clear.
RP_SQ_WR	Read/Write Flag for Record Path Switch Queue operation 1 Write to Switch Queue 0 Read from Switch Queue
RP_SQ_RW_DONE	Read Only
RP_CONFIG_DONE	After any configuration changes are made to the record path control registers, this bit should be set to resume the record path operation.

Address	[7]	[6]	[5]	[4]	[3]	[2]	[1]	[0]
0x209	RP_SQ_DATA[7:0]							
0x20A	RP_SQ_DATA[15:8]							
0x20B	RP_SQ_DATA[23:16]							
0x20C	RP_SQ_DATA[31:24]							

RP\_SQ\_DATA0 ~ 3 are used to read/write the data from/to the record path switch queue entry when a switch queue read/write operation is performed.

In write operation, these 4 registers are written first. Then a command is issued using RP\_SQ\_CMD in 0x208 to move the data into the switching queue.

In read operation, a read command is issued using RP\_SQ\_CMD in 0x208 to move the data from switch queue into these 4 registers. The MCU can then read the entry from these registers.

The definition of each bit used in the switch queue entry is as follows.

RP_SQ_DATA[1:0]	Port ID for channel 0 (upper left window)
RP_SQ_DATA[3:2]	Chip ID for channel 0
RP_SQ_DATA[5:4]	Port ID for Channel 1 (upper right window)
RP_SQ_DATA[7:6]	Chip ID for Channel 1
RP_SQ_DATA[9:8]	Port ID for Channel 2 (Lower left window)
RP_SQ_DATA[11:10]	Chip ID for Channel 2
RP_SQ_DATA[13:12]	Port ID for Channel 3 (Lower right window)
RP_SQ_DATA[15:14]	Chip ID for Channel 3
RP_SQ_DATA[19:16]	Channel 0 ~ 3 disable bit. Bit 16 set to 1, Channel 0 is disabled. Bit 17 set to 1, Channel 1 is disabled Bit 18 set to 1, Channel 2 is disabled Bit 19 set to 1, Channel 3 is disabled
RP_SQ_DATA[22:20]	Picture Type, as shown in Figure 15
RP_SQ_DATA[23]	Strobe field type for field mode picture type. 1      Odd field 0      Even field
RP_SQ_DATA[25:24]	Field/Frame based OSD0 selection for Record Output Port 0. There will be 4 sets of OSD0 configuration information. These 2 bits selects one of the 4 sets for record output port 0. According to the setting of these 2 bits, the OSD result can change from field to field or frame to frame.
RP_SQ_DATA[27:26]	Field/Frame based OSD1 selection for Record Output Port 1. There will be 4 sets of OSD1 configuration information. These 2 bits selects one of the 4 sets for record output port 1. According to the setting of these 2 bits, the OSD result can change from field to field or frame to frame.
RP_SQ_DATA[31:28]	Reserved

Address	[7]	[6]	[5]	[4]	[3]	[2]	[1]	[0]
0x20D	RP_SQ_ADDR[7:0]							
0x20E	RP_SQ_SIZE[7:0]							
0x20F	0	RP_SQ_SIZE[10:8]			0	RP_SQ_ADDR[10:8]		

**RP\_SQ\_ADDR** The switch queue entry address to perform the switch queue read / write command. This address is automatically incremented after the command is performed

**RP\_SQ\_SIZE** The switch queue size.  
 1-2047: 1-2047  
 2048: 0

## RECORD CHID ENCODER

Address	[7]	[6]	[5]	[4]	[3]	[2]	[1]	[0]
0x216	RP_MOTN_ID_EN	RP_DIG_ID_EN	RP_ANA_ID_EN	RP_ANA_RIC_EN	RP_AUTO_ID_EN	RP_AUTO_RPT_EN	RP_DET_ID_EN	RP_USR_ID_EN

**RP\_MOTN\_ID\_EN** 1 Turn on motion information encoding  
 0 Do not turn on motion information encoding

**RP\_DIG\_ID\_EN** 1 Turn on the digital channel ID encoding  
 0 Turn off the digital channel ID encoding

**RP\_ANA\_ID\_EN** 1 Turn on the analog channel ID encoding  
 0 Turn off the analog channel ID encoding

**RP\_ANA\_RPT\_EN** 1 Turn on the analog auto channel ID repeat line  
 0 Turn off the analog auto channel ID repeat line

**RP\_AUTO\_ID\_EN** 1 Turn on the auto channel ID encoding  
 0 Turn off the auto channel ID encoding

**RP\_DET\_ID\_EN** 1 Turn on the detection ID encoding  
 0 Turn off the detection ID encoding

**RP\_USR\_ID\_EN** 1 Turn on the user information encoding  
 0 Turn off the user information encoding

Address	[7]	[6]	[5]	[4]	[3]	[2]	[1]	[0]
0x217	RP_ANA_CHID_H_OFST							

**RP\_ANA\_CHID\_H\_OFST** The horizontal starting offset for Analog Channel ID

Address	[7]	[6]	[5]	[4]	[3]	[2]	[1]	[0]
0x218	RP_ANA_CHID_HIGH							
0x219	RP_ANA_CHID_LOW							

**RP\_ANA\_CHID\_HIGH** Pixel values bigger than this setting are interpreted as "1" for Analog Channel ID (default: 235)

**RP\_ANA\_CHID\_LOW** Pixel values smaller than this setting are interpreted as "0" for Analog Channel ID (default: 16)

Address	[7]	[6]	[5]	[4]	[3]	[2]	[1]	[0]
---------	-----	-----	-----	-----	-----	-----	-----	-----

0x21A	RP_CHID_V_OFSTO	0	RP_CHID_V_OFST
0x21B	RP_CHID_V_OFSTE	RP_USR_ID_PT_SEL	RP_ANA_CHID_BW

**RP\_CHID\_V\_OFSTO** Control the vertical starting offset on top of RP\_CHID\_V\_OFST in odd field for Analog Channel ID

**RP\_CHID\_V\_OFSTE** Control the vertical starting offset on top of RP\_CHID\_V\_OFST in even field for Analog Channel ID

**RP\_CHID\_V\_OFST** Vertical starting offset for Analog Channel ID. The actual vertical line offset is  $RP\_CHID\_V\_OFST + RP\_CHID\_V\_OFSTO$  or  $RP\_CHID\_V\_OFST + RP\_CHID\_V\_OFSTE$

**RP\_ANA\_CHID\_BW** Control the pixel width of each bit for Analog Channel ID  
 0 1 pixel  
 : :  
 31 32 pixels (default)

**RP\_USER\_ID\_PT\_SEL** This bit is used to select the user channel ID registers in 0x220 ~ 0x227 information is to be used for either record port 0 or 1  
 0 0x220 ~ 0x227 are used for record port 0  
 1 0x220 ~ 0x227 are used for record port 1

Address	[7]	[6]	[5]	[4]	[3]	[2]	[1]	[0]
0x21C		RP_SMALL_FR	RP_BI_CLK	RP_BYPASS	RP_GEN_CTL			

**RP\_GEN\_CTL** Internal test function

**RP\_BYPASS** Enable bypass from video decoder to record output pin with byte-interleaving format  
 0 Disable bypass  
 1 Enable bypass

**RP\_BI\_CLK** Use 27 MHz CLK0Y and CLK0YB for Byte Interleaving Output. This bit is valid only when RP\_BYPASS is set to 1.  
 0 27 MHz  
 1 54 MHz

**RP\_SMALL\_FR** Internal test function

Address	[7]	[6]	[5]	[4]	[3]	[2]	[1]	[0]
0x21D	RP_CHNUM1			RP_CHNUM0				
0x21E	RP_CHNUM3			RP_CHNUM2				
0x21F								RP_GEN_FLDPOL

**RP\_CHNUM** The Channel Number to display in non-switch mode  
 [3:2] CHIP ID  
 [1:0] PORT ID

**RP\_GEN\_FLDPOL** Reverse the field polarity of the internal pattern generator for RP path.

Address	[7]	[6]	[5]	[4]	[3]	[2]	[1]	[0]
---------	-----	-----	-----	-----	-----	-----	-----	-----

0x220	RP_USER_CHID[7:0]
0x221	RP_USER_CHID[15:8]
0x222	RP_USER_CHID[23:16]
0x223	RP_USER_CHID[31:24]
0x224	RP_USER_CHID[39:32]
0x225	RP_USER_CHID[47:40]
0x226	RP_USER_CHID[55:48]
0x227	RP_USER_CHID[63:56]

**RP\_USER\_CHID**

Used to set the USER Channel ID for record path.

Depending on the RP\_USER\_ID\_PT\_SEL (0x21B bit 5), these can be used to read/write the user channel ID for record port 0, or record port 1. Always set RP\_USER\_ID\_PT\_SEL before any read/write to these registers

**DISPLAY CONTROL**

Address	[7]	[6]	[5]	[4]	[3]	[2]	[1]	[0]
0x230	DP_BLANK_COLR				DP_BGND_COLR			

**DP\_BLANK\_COLR[3]**

- 1 Blue
- 0 Gray, the gray level is selected by DP\_BLANK\_COLR[2:0]

**DP\_BLANK\_COLR[2:0]**

- 0 ~ 3 Black
- 4 Gray darkest
- 5 Gray darker
- 6 Gray lighter
- 7 Gray lightest

**DP\_BGND\_COLR[3]**

- 1 Blue
- 0 Gray, the gray level is selected by DP\_BGND\_COLR[2:0]

**DP\_BGND\_COLR[2:0]**

- 0 ~ 3 Black
- 4 Gray darkest
- 5 Gray darker
- 6 Gray lighter
- 7 Gray lightest

Address	[7]	[6]	[5]	[4]	[3]	[2]	[1]	[0]
0x231	DP_LIM_656		DP_CVBS_VSPOL				DP_FIELD_ID	DP_WINWIDTH

DP\_LIM\_656

656 Data Clamping

For Y:

DP\_LIM\_656[2]

0 Maximum limit to 254

1 Maximum limit to 235

DP\_LIM\_656[1:0]

0 Minimum set to 1

1 Minimum set to 16

2 Minimum set to 24

3 Minimum set to 32

For C

DP\_LIM\_656

0 Maximum 254, Minimum 1

1~7 Maximum 240, Minimum 16

DP\_CVBS\_VSPOL

0

Do not reverse the VS polarity for CVBS

1

Reverse the VS polarity for CVBS

DP\_FIELD\_ID

1

Force the output to de-interlacer to top field

0

Do not force field ID to top field

DP\_WINWIDTH

1

1440 pixels maximum per line

0

720 pixels maximum per line

Address	[7]	[6]	[5]	[4]	[3]	[2]	[1]	[0]
0x232	DP_SOFTRST	DP_DI_FLDPOL	0	0	0	0	0	0

DP\_SOFTRST

1

Reset Display Path

0

Do not reset the display path

DP\_DI\_FLDPOL

1

Reverse the field polarity to the VGA de-interlacer

0

Do not reverse the field polarity to the de-interlacer

Address	[7]	[6]	[5]	[4]	[3]	[2]	[1]	[0]
0x237	DP_CAS_IN_EN							

DP\_CAS\_IN\_EN

Enable the display cascade input

Address	[7]	[6]	[5]	[4]	[3]	[2]	[1]	[0]
0x238							1	0

Reserved

Address	[7]	[6]	[5]	[4]	[3]	[2]	[1]	[0]
0x23A	DP_BORDER_BLINK							

**DP\_BORDER\_BLINK**      **1**      Turn on border blinking for the corresponding window 0 ~ 7  
**0**      Turn off border blinking

Address	[7]	[6]	[5]	[4]	[3]	[2]	[1]	[0]
0x23B						DP_VGA_FLDPOL	DP_CVBS_FLDPOL	DP_VD_FLDPOL

**DP\_VGA\_FLDPOL**      Reverse the field polarity for the display VGA output  
**DP\_CVBS\_FLDPOL**      Reverse the field polarity for the display CVBS output  
**DP\_VD\_FLDPOL**      Reverse the field polarity of the incoming video stream

Address	[7]	[6]	[5]	[4]	[3]	[2]	[1]	[0]
0x23C	DP_FREEZEOPT[7:0]							
0x23D	DP_ADAPT_EN[7:0]							

**DP\_FREEZEOPT**      **0**      Display field only when freeze command is issued or underflow condition occurs  
**1**      Display frame when freeze command is issued or underflow condition occurs  
**DP\_ADAPT\_EN**      **0**      Display field/frame according to DP\_FREEZEOPT  
**1**      Overwrite DP\_FREEZEOPT and display frame when no\_motion is asserted

Address	[7]	[6]	[5]	[4]	[3]	[2]	[1]	[0]	
0x23E	NON_REALTIME[7:0]								
0x23F	FRCE_BLNK_SEL	FRCE_BLNK_GRY_LVL							NON_REALTIME[8]

**NON\_REALTIME[n]**      **0**      Display non-real-time video source at display window n, n = 0 ~ 8. n equals 8 specifies the display cascade input.  
**1**      Display real-time Video Sources at display window n, n = 0 ~ 8. n equals 8 specifies the display cascade input.

**FRCE\_BLNK\_GRY\_LVL**      These bit only work when the DP\_BLNKm Register bit is set (0x250[0], 0x258[0], ....., etc.)  
**0xx**      Black  
**100**      25% Gray  
**101**      40% Gray  
**110**      75% Gray  
**111**      100% Gray

**FRCE\_BLNK\_SEL** This bit only work when the DP\_BLNKm Register bit is set (0x250[0], 0x258[0], ....., etc.)

**0**      Gray  
**1**      Blue

Address	[7]	[6]	[5]	[4]	[3]	[2]	[1]	[0]
---------	-----	-----	-----	-----	-----	-----	-----	-----



0x240	DP_VGA_HDELAY[7:0]							
0x241	DP_VGA_HACTIVE[7:0]							
0x242	DP_VGA_HACTIVE[10:8]				DP_VGA_HDELAY[10:8]			
0x243	DP_VGA_VDELAY[7:0]							
0x244	DP_VGA_VACTIVE[7:0]							
0x245	DP_VGA_VACTIVE[10:8]				DP_VGA_VDELAY[10:8]			

DP\_VGA\_HDELAY      VGA Cropping HDELAY

DP\_VGA\_HACTIVE    VGA Cropping HACTIVE

DP\_VGA\_VDELAY     VGA Cropping VDELAY

DP\_VGA\_VACTIVE    VGA Cropping VACTIVE

Address	[7]	[6]	[5]	[4]	[3]	[2]	[1]	[0]
0x24C	DP_BORDER_COLR			0	DP_PBVD_SEL			

DP\_BORDER\_COLR    Select the color of the display window border

DP\_PBVD\_SEL        Select the source of display window 0 ~ 3 to be from PB\_CH0 ~ PB\_CH3 or from video decoders VDO ~ VD3

0      PB

1      VD

Address	[7]	[6]	[5]	[4]	[3]	[2]	[1]	[0]
0x24D	DP_CHNAB_SEL							

DP\_CHNAB\_SEL      Select the Analog Switch A/B for each window 0 ~ 7

Address	[7]	[6]	[5]	[4]	[3]	[2]	[1]	[0]
0x24E	DP_BORDER_EN							

DP\_BORDER\_EN      Enable display window borders for each window 0 ~ 7

Address	[7]	[6]	[5]	[4]	[3]	[2]	[1]	[0]
0x24F	DP_STRB_REQ							

DP\_STRB\_REQ        Strobe Request to each of the 8 windows. Self clear after the strobe is done

Address	[7]	[6]	[5]	[4]	[3]	[2]	[1]	[0]
0x250	DP_CH_EN0	DP_FREEZE0	DP_STRB_FLD0		DP_FUNC_MD0		DP_RD_V_2X0	DP_BLNK0
0x258	DP_CH_EN1	DP_FREEZE1	DP_STRB_FLD1		DP_FUNC_MD1		DP_RD_V_2X1	DP_BLNK1
0x260	DP_CH_EN2	DP_FREEZE2	DP_STRB_FLD2		DP_FUNC_MD2		DP_RD_V_2X2	DP_BLNK2
0x268	DP_CH_EN3	DP_FREEZE3	DP_STRB_FLD3		DP_FUNC_MD3		DP_RD_V_2X3	DP_BLNK3
0x270	DP_CH_EN4	DP_FREEZE4	DP_STRB_FLD4		DP_FUNC_MD4		DP_RD_V_2X4	DP_BLNK4
0x278	DP_CH_EN5	DP_FREEZE5	DP_STRB_FLD5		DP_FUNC_MD5		DP_RD_V_2X5	DP_BLNK5
0x280	DP_CH_EN6	DP_FREEZE6	DP_STRB_FLD6		DP_FUNC_MD6		DP_RD_V_2X6	DP_BLNK6
0x288	DP_CH_EN7	DP_FREEZE7	DP_STRB_FLD7		DP_FUNC_MD7		DP_RD_V_2X7	DP_BLNK7

DP_CH_ENm	1	Enable window m
	0	Disable window m
DP_FREEZE <sub>m</sub>	1	Freeze window m
	0	Do not freeze window m
DP_STRB_FLD <sub>m</sub>	0	Strobe at Odd Field
	1	Strobe at Even Field
	2/3	Strobe at Frame
DP_FUNC_MD <sub>m</sub>	0	LIVE Mode
	1	Strobe Mode
	2/3	Reserved
DP_RD_V_2X <sub>m</sub>	1	Scale Up 2X vertically (For CIF becoming D1)
	0	Do not scale up 2X
DP_BLNK <sub>m</sub>	1	Force the window m to display blank color
	0	Show normal video in the window m

Address	[7]	[6]	[5]	[4]	[3]	[2]	[1]	[0]
0x251					DP_OVWR_V2X0	DP_MIR_H_0	DP_MIR_V_0	
0x259					DP_OVWR_V2X1	DP_MIR_H_1	DP_MIR_V_1	
0x261					DP_OVWR_V2X2	DP_MIR_H_2	DP_MIR_V_2	
0x269					DP_OVWR_V2X3	DP_MIR_H_3	DP_MIR_V_3	
0x271					DP_OVWR_V2X4	DP_MIR_H_4	DP_MIR_V_4	
0x279					DP_OVWR_V2X5	DP_MIR_H_5	DP_MIR_V_5	
0x281					DP_OVWR_V2X6	DP_MIR_H_6	DP_MIR_V_6	
0x289					DP_OVWR_V2X7	DP_MIR_H_7	DP_MIR_V_7	

DP_OVWR_V2X		Force V2X write, instead of following pic_type. I.e., write even line to top field, and odd line to bottom field.
DP_MIR_H_n	1	Mirror horizontally
	0	Do not mirror horizontally
DP_MIR_V_n	1	Mirror vertically
	0	Do not mirror vertically

Address	[7]	[6]	[5]	[4]	[3]	[2]	[1]	[0]
0x252	DP_PICHL0[7:0]							
0x253	DP_PICHR0[7:0]							
0x254	DP_PICVT0							
0x255	DP_PICVB0							
0x256		0		DP_PICHR0[8]				DP_PICHL0[8]
0x25A	DP_PICHL1[7:0]							
0x25B	DP_PICHR1[7:0]							
0x25C	DP_PICVT1							
0x25D	DP_PICVB1							
0x25E		1		DP_PICHR1[8]				DP_PICHL1[8]
0x262	DP_PICHL2[7:0]							
0x263	DP_PICHR2[7:0]							
0x264	DP_PICVT2							
0x265	DP_PICVB2							
0x266		2		DP_PICHR2[8]				DP_PICHL2[8]
0x26A	DP_PICHL3[7:0]							
0x26B	DP_PICHR3[7:0]							
0x26C	DP_PICVT3							
0x26D	DP_PICVB3							
0x26E		3		DP_PICHR3[8]				DP_PICHL3[8]
0x272	DP_PICHL4[7:0]							
0x273	DP_PICHR4[7:0]							
0x274	DP_PICVT4							
0x275	DP_PICVB4							
0x276		4		DP_PICHR4[8]				DP_PICHL4[8]
0x27A	DP_PICHL5[7:0]							
0x27B	DP_PICHR5[7:0]							
0x27C	DP_PICVT5							
0x27D	DP_PICVB5							
0x27E		5		DP_PICHR5[8]				DP_PICHL5[8]
0x282	DP_PICHL6[7:0]							
0x283	DP_PICHR6[7:0]							
0x284	DP_PICVT6							
0x285	DP_PICVB6							
0x286		6		DP_PICHR6[8]				DP_PICHL6[8]
0x28A	DP_PICHL7[7:0]							
0x28B	DP_PICHR7[7:0]							
0x28C	DP_PICVT7							
0x28D	DP_PICVB7							
0x28E		7		DP_PICHR7[8]				DP_PICHL7[8]

- DP\_PICHLm**            The left edge horizontal location of window m in unit of 16 pixels
- DP\_PICHRm**            The right edge horizontal location of window m in unit of 16 pixels
- DP\_PICVTm**            The upper edge vertical location of window m in unit of 8 lines
- DP\_PICVBm**            The lower edge vertical location of window m in unit of 8 lines
- DP\_PRIIm**            The window m priority when they overlap with each other. 0 has the top priority, while 7 has the least priority

Address	[7]	[6]	[5]	[4]	[3]	[2]	[1]	[0]
---------	-----	-----	-----	-----	-----	-----	-----	-----

0x257				DP_WR_CH_EN[8]				DP_WR_EN
0x267	DP_WR_CH_EN[7:0]							

**DP\_WR\_EN** Enable write to the display buffer. This bit is combined with DP\_WR\_CH\_EN ({0x257[4], 0x267[7:0]}) for the per window control. I.e., use DP\_WR\_CH\_EN to select which windows will be controlled, and then use DP\_WR\_EN to do the actual enable / disable.

**DP\_WR\_CH\_EN** {0x257[4], 0x267[7:0]} controls per-window display write buffer control. These bit work together with 0x257[0].

Address	[7]	[6]	[5]	[4]	[3]	[2]	[1]	[0]
0x27F	DP_BASE_ADDR							

**DP\_BASE\_ADDR** The base address of the display buffer. In unit of 128 Kbytes  
The DDR address generated with DP\_BASE\_ADDR is {DP\_BASE\_ADDR, 17'h0}

Address	[7]	[6]	[5]	[4]	[3]	[2]	[1]	[0]
0x28F	DP_TEST							

**DP\_TEST** Default 0

**SPOT CONTROL**

Address	[7]	[6]	[5]	[4]	[3]	[2]	[1]	[0]
0x290	0	0	SP_INP_FLD_POL	SP_CC_EN				

SP_INP_FLD_POL		Reverse the field polarity for spot path only
SP_CC_EN[1]	1	SPOT Cascade Output Enable
	0	SPOT Cascade Output Disable
SP_CC_EN[0]	1	SPOT Cascade Input Enable. The SPOT clock is the clock from SPOT cascade input clock.
	0	SPOT Cascade Input Disable. The SPOT clock is a 27 MHz clock generated internally

Address	[7]	[6]	[5]	[4]	[3]	[2]	[1]	[0]
0x291	SP_BLANK_COLR		SP_BGND_COLR		SP_BLANK_MODE		SP_BORDER_EN	0

SP_BLANK_COLR		The blank color of the video window that does not have active video source or forced to show the blank color
	0	Dark Gray
	1	Intermediate Gray
	2	Bright Gray
	3	Blue
SP_BGND_COLR		The background color outside of the video window configured picture.
	0	Dark Gray
	1	Intermediate Gray
	2	Bright Gray
	3	Blue
SP_BLANK_MODE	0	Show blank color as specified by SP_BLANK_COLR When the NO_VIDEO is detected
	1	Shows the last image captured when the NO_VIDEO is detected
	2	Display blank color specified by SP_BLANK_COLR with border blinking when NO_VIDEO is detected (valid only if SP_BORDER_EN is on)
	3	Display the last image captured with border blinking when the NO_VIDEO is detected (valid only if SP_BORDER_EN is on)
SP_BORDER_EN	1	Enable displaying SPOT border
	0	Disable displaying SPOT border

Address	[7]	[6]	[5]	[4]	[3]	[2]	[1]	[0]
0x292	SP_BORDER_COLR			0	0	SP_LIM_656		

**SP\_LIM\_656**                      656 data value clamping selection  
For Y

**SP\_LIM\_656[2]**  
**1**      Maximum is 235  
**0**      Maximum is 254

**SP\_LIM\_656[1:0]**  
**0**      Minimum is 1  
**1**      Minimum is 16,  
**2**      Minimum is 24  
**3**      Minimum is 32

For C

**SP\_LIM\_656**  
**0~1**    Maximum 254, Minimum 1  
**2 ~ 7**   Maximum 240, Minimum 16

**SP\_BORDER\_COLR**

**0**      Black  
**1**      Dark gray  
**2**      Light gray  
**3**      White

Address	[7]	[6]	[5]	[4]	[3]	[2]	[1]	[0]
0x293	SP_H_OFFSET							
0x294	0	SP_V_OFFSET						
0x295	SP_H_SIZE[7:0]							
0x296	SP_V_SIZE[7:0]							
0x297	0	0	0	0	0	SP_V_SIZE[8]	SP_H_SIZE[9:8]	

**SP\_H\_OFFSET**                      The horizontal offset of the first active pixel in the output 656/601 format

**SP\_V\_OFFSET**                      The vertical offset of the first active line in the output 656/601 format

**SP\_H\_SIZE**                         The horizontal active length used to show the video pictures

**SP\_V\_SIZE**                         The vertical active height used to show the video pictures

Address	[7]	[6]	[5]	[4]	[3]	[2]	[1]	[0]
0x2A0	SP_CH_EN_0	SP_FREEZE_0	SP_FUNC_MD_0	SP_ANA_0	0	SP_BLNK_0	SP_MIR_V_0	SP_MIR_H_0
0x2A1	SP_CH_EN_1	SP_FREEZE_1	SP_FUNC_MD_1	SP_ANA_1	0	SP_BLNK_1	SP_MIR_V_1	SP_MIR_H_1
0x2A2	SP_CH_EN_2	SP_FREEZE_2	SP_FUNC_MD_2	SP_ANA_2	0	SP_BLNK_2	SP_MIR_V_2	SP_MIR_H_2
0x2A3	SP_CH_EN_3	SP_FREEZE_3	SP_FUNC_MD_3	SP_ANA_3	0	SP_BLNK_3	SP_MIR_V_3	SP_MIR_H_3

<b>SP_CH_EN</b>	Channel Enable Control for each of channel 0 through 3 <b>1</b> Enable channel <b>0</b> Disable channel
<b>SP_FREEZE</b>	<b>1</b> Freeze the video <b>0</b> Disable freeze
<b>SP_FUNC_MD</b>	When the SPOT Path is not in Switch mode, this bit specifies the SPOT mode of <b>1</b> Strobe Mode <b>0</b> Live Mode
<b>SP_ANA</b>	Specify the analog input selection of each of the channel. <b>0</b> VINA <b>1</b> VINB
<b>SP_BLNK</b>	Force the channel to display blank color <b>1</b> Blank Color <b>0</b> Normal video
<b>SP_MIR_V</b>	Control to mirror the image vertically for each channel <b>0</b> Do not mirror vertically <b>1</b> Mirror vertically
<b>SP_MIR_H</b>	Control to mirror the image horizontally for each channel <b>0</b> Do not mirror horizontally <b>1</b> Mirror horizontally

Address	[7]	[6]	[5]	[4]	[3]	[2]	[1]	[0]
0x2A4	0	0	0	0	SP_STROBE_3	SP_STROBE_2	SP_STROBE_1	SP_STROBE_0

<b>SP_STROBE</b>	Strobe command for each channel. Once set to <b>1</b> , the corresponding channel will capture one field/frame and then clear this bit.
------------------	---

Address	[7]	[6]	[5]	[4]	[3]	[2]	[1]	[0]
0x2A5	0	SP_STRB_FLD	SP_CH_CYCLE		SP_SM_EN	SP_PIC_TYPE		

SP_STRB_FLD	In non-switch mode, this bit controls which field to capture in field mode ( pic_type 0, 2, 4, 6, 7) 0 Capture Even field 1 Capture Odd field
SP_CH_CYCLE	In non-switch mode, this SP_CH_CYCLE controls how many channels to interleave when the pic_type is 0, 1, 6, and 7.  PIC_TYPE 0, 1 0 Capture and interleave channel 0, 1, 2, 3 1 Capture channel 0 2 Capture and interleave channel 0, 1 3 Capture and interleave channel 0, 1, 2 PIC_TYPE 6, 7 1 Capture channel 0, 1 2 Capture and interleave channel 0, 1, 2, 3
SP_SM_EN	1 SPOT Path is in Switch Queue Mode 0 SPOT Path is in Live or Strobe Mode
SP_PIC_TYPE	When SPOT Path is not in Switch Queue Mode, SP_PIC_TYPE specifies the pic_type used in LIVE/Strobe mode

## SPOT SWITCH QUEUE

Address	[7]	[6]	[5]	[4]	[3]	[2]	[1]	[0]
0x298	SP_SQ_CMD	SP_SQ_WR	SP_SQ_RW_DONE*	0	0	0	0	SP_CONFIG_DONE

SP_SQ_CMD	The command bit to start a SPOT Path Switch Queue read / write operation. Set to 1 to start a command. This bit will self clear.
SP_SQ_WR	Read/Write Flag for SPOT Path Switch Queue operation 1 Write to Switch Queue 0 Read from Switch Queue
SP_SQ_RW_DONE	Read Only
SP_CONFIG_DONE	After any configuration changes are made to the control registers, this bit should be set to resume the SPOT path operation.



Address	[7]	[6]	[5]	[4]	[3]	[2]	[1]	[0]
0x299	SP_SQ_DATA[7:0]							
0x29A	SP_SQ_DATA[15:8]							
0x29B	SP_SQ_DATA[23:16]							

SP\_SQ\_DATA are used to read/write the data from/to the SPOT path switch queue entry when a switch queue read/write operation is performed.

In write operation, these 4 registers are written first. Then a command is issued using SP\_SQ\_CMD in 0x298 to move the data into the switching queue.

In read operation, a read command is issued using SP\_SQ\_CMD in 0x298 to move the data from switch queue into these 4 registers. The MCU can then read the entry from these registers.

The definition of each bit used in the switch queue entry is as follows.

SP_SQ_DATA[1:0]	Port ID for channel 0 (upper left window)
SP_SQ_DATA[3:2]	Chip ID for channel 0
SP_SQ_DATA[5:4]	Port ID for Channel 1 (upper right window)
SP_SQ_DATA[7:6]	Chip ID for Channel 1
SP_SQ_DATA[9:8]	Port ID for Channel 2 (Lower left window)
SP_SQ_DATA[11:10]	Chip ID for Channel 2
SP_SQ_DATA[13:12]	Port ID for Channel 3 (Lower right window)
SP_SQ_DATA[15:14]	Chip ID for Channel 3
SP_SQ_DATA[19:16]	Channel 0 ~ 3 disable bit. Bit 16 set to 1, Channel 0 is disabled. Bit 17 set to 1, Channel 1 is disabled Bit 18 set to 1, Channel 2 is disabled Bit 19 set to 1, Channel 3 is disabled
SP_SQ_DATA[22:20]	Picture Type, as shown in Figure ??.
SP_SQ_DATA[23]	Strobe field type for field mode picture type. 1 Odd field 0 Even field

Address	[7]	[6]	[5]	[4]	[3]	[2]	[1]	[0]
0x29D	SP_SQ_ADDR							
0x29E	SP_SQ_SIZE							

**SP\_SQ\_ADDR** The switch queue entry address to perform the switch queue read / write command. This address is automatically incremented after the command is performed

**SP\_SQ\_SIZE** The switch queue size.  
1 - 15: 1-15  
16: 0

**SPOT CHID ENCODER**

Address	[7]	[6]	[5]	[4]	[3]	[2]	[1]	[0]
0x2A6	SP_MOTN_ID_EN	SP_DIG_ID_EN	SP_ANA_ID_EN	SP_ANA_RIC_EN	SP_AUTO_ID_EN	SP_AUTO_RPT_EN	SP_DET_ID_EN	SP_USR_ID_EN

SP\_MOTN\_ID\_EN      1      Turn on motion information encoding  
                           0      Do not turn on motion information encoding

SP\_DIG\_ID\_EN        1      Turn on the digital channel ID encoding  
                           0      Turn off the digital channel ID encoding

SP\_ANA\_ID\_EN        1      Turn on the analog channel ID encoding  
                           0      Turn off the analog channel ID encoding

SP\_ANA\_RPT\_EN      1      Turn on the analog auto channel ID repeat line  
                           0      Turn off the analog auto channel ID repeat line

SP\_AUTO\_ID\_EN       1      Turn on the auto channel ID encoding  
                           0      Turn off the auto channel ID encoding

SP\_DET\_ID\_EN        1      Turn on the detection ID encoding  
                           0      Turn off the detection ID encoding

SP\_USR\_ID\_EN        1      Turn on the user information encoding  
                           0      Turn off the user information encoding

Address	[7]	[6]	[5]	[4]	[3]	[2]	[1]	[0]
0x2A7	SP_ANA_CHID_H_OFST							

**SP\_ANA\_CHID\_H\_OFST**

The horizontal starting offset for Analog Channel ID

Address	[7]	[6]	[5]	[4]	[3]	[2]	[1]	[0]
0x2A8	SP_ANA_CHID_HIGH							
0x2A9	SP_ANA_CHID_LOW							

SP\_ANA\_CHID\_HIGH    Pixel values bigger than this setting are interpreted as “1” for Analog Channel ID (default: 235)

SP\_ANA\_CHID\_LOW     Pixel values smaller than this setting are interpreted as “0” for Analog Channel ID (default: 16)

Address	[7]	[6]	[5]	[4]	[3]	[2]	[1]	[0]
0x2AA	SP_CHID_V_OFSTO		0	SP_CHID_V_OFST				
0x2AB	SP_CHID_V_OFSTE		0	SP_ANA_CHID_BW				

**SP\_CHID\_V\_OFSTO** Control the vertical starting offset on top of SP\_CHID\_V\_OFST in odd field for Analog Channel ID

**SP\_CHID\_V\_OFSTE** Control the vertical starting offset on top of SP\_CHID\_V\_OFST in even field for Analog Channel ID

**SP\_CHID\_V\_OFST** Vertical starting offset for Analog Channel ID. The actual vertical line offset is  $SP\_CHID\_V\_OFST + SP\_CHID\_V\_OFSTO$  or  $SP\_CHID\_V\_OFST + SP\_CHID\_V\_OFSTE$

**SP\_ANA\_CHID\_BW** Control the pixel width of each bit for Analog Channel ID  
 0 1 pixel  
 : :  
 31 32 pixels (default)

Address	[7]	[6]	[5]	[4]	[3]	[2]	[1]	[0]
0x2AC	0	0	0	0	0	0	0	SP_GEN_EN

**SP\_GEN\_EN** Internal Test Function  
Default 0

Address	[7]	[6]	[5]	[4]	[3]	[2]	[1]	[0]
0x2AD	SP_CHNUM1				SP_CHNUM0			
0x2AE	SP_CHNUM3				SP_CHNUM2			

**SP\_CHNUM** The Channel Number to display in non-switch mode  
 SP\_CHNUMx[3:2]: CHIP ID  
 SP\_CHNUMx[1:0]: PORT ID

Address	[7]	[6]	[5]	[4]	[3]	[2]	[1]	[0]
0x2B0	SP_USER_CHID[7:0]							
0x2B1	SP_USER_CHID[15:8]							
0x2B2	SP_USER_CHID[23:16]							
0x2B3	SP_USER_CHID[31:24]							
0x2B4	SP_USER_CHID[39:32]							
0x2B5	SP_USER_CHID[47:40]							
0x2B6	SP_USER_CHID[55:48]							
0x2B7	SP_USER_CHID[63:56]							

**SP\_USER\_CHID** Used to set the USER Channel ID for SPOT path.

Address	[7]	[6]	[5]	[4]	[3]	[2]	[1]	[0]
0x2C0								SP_16

**SP\_16** 16 Window Display Mode

Address	[7]	[6]	[5]	[4]	[3]	[2]	[1]	[0]
0x2C1	SP_16_WINNUM1				SP_16_WINNUM0			
0x2C2	SP_16_WINNUM3				SP_16_WINNUM2			

**SP\_16\_WINNUM** The window location of the 16 window configuration. The 16 windows are arranged as shown in the following figure.

0	1	2	3
4	5	6	7
8	9	10	11
12	13	14	15

**FIGURE 58. THE WINDOW ID OF THE 16 WINDOW CONFIGURATION**

## Display CVBS Processing

### DOWN-SCALING

Address	[7]	[6]	[5]	[4]	[3]	[2]	[1]	[0]
0x1C0	CVBS_SCL_HACTIVE[7:0]							
0x1C1	CVBS_SCL_VACTIVE[7:0]							
0x1C2				CVBS_SCL_VACTIVE[8]				CVBS_SCL_HACTIVE[9:8]

**CVBS\_SCL\_HACTIVE** The horizontal active pixel number for display CVBS path downscaler

**CVBS\_SCL\_VACTIVE** The vertical active line number for display CVBS path downscaler

Address	[7]	[6]	[5]	[4]	[3]	[2]	[1]	[0]
0x1C3	CVBS_VSCALE[7:0]							
0x1C4	CVBS_VSCALE[15:8]							
0x1C6	CVBS_HSCALE[7:0]							
0x1C7	CVBS_HSCALE[15:8]							

**CVBS\_VSCALE** The vertical scaling factor for display CVBS path downscaler. 0x1FFF is scaling factor of 1.

$CVBS\_VSCALE = \text{Input line number (CVBS\_SCL\_VACTIVE)} * 8191 / (\text{Output line number} + 1)$

**\*\*Note:** line number means the number of lines in a field

**CVBS\_HSCALE** The horizontal factor for display CVBS path downscaler. 0x1FFF is scaling factor of 1,

$CVBS\_HSCALE = \text{Input pixel number (CVBS\_SCL\_HACTIVE)} * 8191 / (\text{Output pixel number} + 1)$

Address	[7]	[6]	[5]	[4]	[3]	[2]	[1]	[0]
0x1C5	CVBS_ODD_SKEW				CVBS_EVEN_SKEW			

**CVBS\_ODD\_SKEW** Additional vertical offset on odd fields

**CVBS\_EVEN\_SKEW** Additional vertical offset on even fields

Address	[7]	[6]	[5]	[4]	[3]	[2]	[1]	[0]
0x1C8	CVBS_LIM656	CVBS_V_OFST	CVBS_VSYNC_POL	CVBS_HSYNC_POL	CVBS_HSFLT		CVBS_VSFLT	

CVBS_LIM656	1	Limit the CVBS display pixel outputs (YUV) to between 16 and 235 (Default)
	0	Limit the CVBS display pixel outputs (YUV) to between 1 and 254
CVBS_V_OFST	1	Enable using different offset for EVEN/ODD field during vertical scaling (Default)
	0	Use the same offset for EVEN/ODD field during vertical scaling
CVBS_VSYNC_POL	1	Reverse the VS polarity for CVBS display (Default)
	0	Do not reverse the VS polarity for CVBS display
CVBS_HSYNC_POL	1	Reverse the HS polarity for CVBS display (Default)
	0	Do not reverse the HS polarity for CVBS display
CVBS_HSFLT		Select the CVBS display horizontal downscaler anti-aliasing filter mode
	0	Full bandwidth (Default)
	1	2 MHz bandwidth
	2	1.5 MHz bandwidth
	3	1 MHz bandwidth
CVBS_VSFLT		Select the CVBS display vertical downscaler anti-aliasing filter mode
	0	Full bandwidth (Default)
	1	0.25 line-rate bandwidth
	2,3	0.18 line-rate bandwidth

Address	[7]	[6]	[5]	[4]	[3]	[2]	[1]	[0]
0x1C9	0	0	0	0	CVBS_FLD_POL	CVBS_T_FDLY	CVBS_T_VSCL	CVBS_T_CPALDLY

CVBS_FLD_POL	1	Reverse the Display CVBS field polarity
	0	Do not reverse the field polarity
CVBS_T_FDLY		Set display CVBS scaler field delay mode for testing
CVBS_T_VSCL		Set display CVBS vertical scaler scaling factor to be 1 for testing
CVBS_T_CPALDLY		Set display CVBS scaler chroma delay in PAL mode

Address	[7]	[6]	[5]	[4]	[3]	[2]	[1]	[0]
0x1CA	CVBS_TEST					CVBS_SOFT_RST	CVBS_HSCL_BP	CVBS_PALDLY

CVBS_TEST	0001	Enable display CVBS scaler test pattern with data valid from the pattern generator
	0010	Enable display CVBS scaler test pattern with data valid from the display path
CVBS_SOFT_RST		Display CVBS scaler software reset
CVBS_HSCL_BP		Bypass display CVBS horizontal scaler
CVBS_PALDLY		Set PAL delay mode

Address	[7]	[6]	[5]	[4]	[3]	[2]	[1]	[0]
0x1CB		C_V_START						
0x1CC	C_V_END [7:0]							
0x1CD	C_LINE_INS							C_V_END[8]

C_V_START		Set the starting line number of active video shown in PAL mode
C_V_END		Set the end line number of active video shown in PAL mode
C_LINE_INS		Enable inserting blanking lines at the beginning and end in PAL mode

## Display VGA / LCD Processing

Address	[7]	[6]	[5]	[4]	[3]	[2]	[1]	[0]
0x480							VGA_RD_RST	VGA_RST

VGA_RST		Software Reset for VGA / De-Interlacer / Brightness Control / RGB control, timing generation modules. When this bit is set, the VGA sync is lost.
VGA_RD_RST		Software Reset of the video buffer read side of the VGA path. When this bit is set, the VGA output become blanks, and the VGA sync is not lost. This bit can be set when the display configuration change is performed.

Address	[7]	[6]	[5]	[4]	[3]	[2]	[1]	[0]
0x4E0						USE_GAMMAB	USE_GAMMAG	USE_GAMMAR
0x4E1	DITHER_BP	S_DM				S_BC		

<b>USE_GAMMAR</b>	Enable red color gamma table
<b>USE_GAMMAG</b>	Enable green color gamma table
<b>USE_GAMMAB</b>	Enable blue color gamma table
<b>S_BC</b>	Output Pixel Width for each of R, G, B value 0: 8:8:8 (default) 1: 6:6:6 2: 5:6:5 3: 5:5:5 4: 4:4:4 5: 3:3:3 6: 3:3:2
<b>S_DM</b>	Dithering mode configuration. This specifies the number of lower bits for dithering.
<b>DITHER_BP</b>	Bypass dithering



Address	[7]	[6]	[5]	[4]	[3]	[2]	[1]	[0]
0x4F0		VGA_BYP_OSD	VGA_BYP_DI	VGA_DATA0	VGA_BYP_HUE	VGA_BYP_YUV	VGA_BYP_SHARP	VGA_BYP_BW
0x4F2	VGA_BWGEN_PTRN		VGA_BWGEN_EN					VGA_CGEN_EN

VGA_BYP_OSD	1	Bypass OSD for the VGA path
	0	Do not bypass OSD
VGA_BYP_DI	1	Bypass DI operation
	0	Does not bypass DI
VGA_DATA0	1	Blank out the whole screen
	0	Normal operation
VGA_BYP_HUE	1	Bypass Hue Control
	0	Does not bypass Hue Control
VGA_BYP_YUV	1	Bypass YUV contrast / gain control
	0	Does not bypass YUV contrast / gain control
VGA_BYP_SHARP	1	Bypass sharpness control
	0	Does not bypass sharpness control
VGA_BYP_BW	1	Bypass black / white stretch control
	0	Does not bypass black / white stretch control
VGA_BWGEN_PTRN	Test pattern for internal use	
	0	Black / White Pattern
	1	Color Pattern
	2	Color Bar
	3	Y Single line
	4	Y block
	5	BW pattern
	6/7	Black
VGA_BWGEN_EN	Pattern Generation Enable for Internal Test only	
VGA_CGEN_EN	Pattern Generation Enable for Internal use only	

Address	[7]	[6]	[5]	[4]	[3]	[2]	[1]	[0]
0x4F3	VGA_DEBUG_DATA[7:4]				VGA_DEBUG_DATA[3:0] * / VGA_DEBUG_SEL			

VGA_DEBUG_SEL	Write only. Set this to select the read back of register 0x4F0
VGA_DEBUG_DATA	The setting of VGA_DEBUG_SEL determines the read back of this register.
	1 BWYMIN
	2 BWYMAX
	3 BWFMIN
	4 BWFMAX
	Others Not valid

**UP-SCALING**

Address	[7]	[6]	[5]	[4]	[3]	[2]	[1]	[0]
0x4A0	UPS_BG_COLR							

**UPS\_BG\_COLR****Background color used for UPS**

Y = {UPS\_BG\_COLR[7:6], 6'b0}

Cb = {UPS\_BG\_COLR[5:3], 5'b0}

Cr = {UPS\_BG\_COLR[2:0], 5'b0}

Address	[7]	[6]	[5]	[4]	[3]	[2]	[1]	[0]
0x4A1	UPS_HST							
0x4A2	UPS_VST							
0x4A3	UPS_HACTIVE_O[7:0]							
0x4A4	UPS_VACTIVE_O[7:0]							
0x4A5	UPS_VACTIVE_O[10:8]				UPS_HACTIVE_O[10:8]			

**UPS\_HST**

Specify the video starting horizontal location in the output video frame

**UPS\_VST**

Specify the video starting vertical location in the output video frame

**UPS\_HACTIVE\_O**

Specify the video width shown in the output video frame after scaling

**UPS\_VACTIVE\_O**

Specify the video height shown in the output video frame after scaling

Address	[7]	[6]	[5]	[4]	[3]	[2]	[1]	[0]
0x4A8	UPS_HACTIVE_IN[7:0]							
0x4A9	UPS_VACTIVE_IN[7:0]							
0x4AA	UPS_VACTIVE_IN[10:8]				UPS_HACTIVE_IN[10:8]			

**UPS\_HACTIVE\_IN**

Specify the upscaler input horizontal video width

**UPS\_VACTIVE\_IN**

Specify the upscaler input vertical video height

Address	[7]	[6]	[5]	[4]	[3]	[2]	[1]	[0]
0x4AB	UPS_HSCALE[7:0]							
0x4AC					UPS_HSCALE[12:0]			
0x4AD	UPS_VSCALE[7:0]							
0x4AE					UPS_VSCALE[10:8]			

**UPS\_HSCALE**

Horizontal scaling factor. 0x1000 represents scaling factor of 1

**UPS\_VSCALE**

Vertical scaling factor. 0x400 represents scaling factor of 1

Address	[7]	[6]	[5]	[4]	[3]	[2]	[1]	[0]
0x4AF								VGA_BLACKOPUT

VGA\_BLACKOUT      1      Black out the VGA output  
                           0      Normal display

## GAMMA TABLE

Address	[7]	[6]	[5]	[4]	[3]	[2]	[1]	[0]
0x488	GAMMA_ADDR[7:0]							
0x489								GAMMA_ADDR[9:8]
0x48A	GAMMA_WDATA[7:0]							
0x48B								GAMMA_WDATA[9:8]
0x48C	GAMMA_RDATA[7:0]*							
0x48D								GAMMA_RDATA[9:8]*
0x48E	GAMMA_RD_START							

GAMMA\_ADDR      Gamma table address

GAMMA\_WDATA      Gamma table write data. The indirect write starts after writing 0x48B

GAMMA\_RDATA      Gamma table read data (Read Only)

GAMMA\_RD\_START      Command to start a read by writing register 0x48E. Data written to 0x48E does not matter.

## 2D DE-INTERLACE

Address	[7]	[6]	[5]	[4]	[3]	[2]	[1]	[0]	
0x490	M2DI_LOW_ANGLE_CNTL								M2DI_USE_BOB

M2DI\_LOW\_ANGLE\_CNTL      Disable a specific criterion to disqualify low angle. Default 0

M2DI\_USE\_BOB      Use BOB instead of low angle. Default 0

Address	[7]	[6]	[5]	[4]	[3]	[2]	[1]	[0]
0x491	0	0	0	1	1	0	0	1
0x492	0	0	1	1	1	1	0	0
0x493	1	1	0	0	1	0	0	0
0x494	1	0	1	1	0	1	0	0
0x495	0	0	0	0	0	0	0	1
0x496	0	0	0	0	1	0	1	0
0x497	0	0	0	0	1	0	1	0

Reserved

Address	[7]	[6]	[5]	[4]	[3]	[2]	[1]	[0]
0x498	M2DI_FRM_WIDTH[7:0]							
0x499	M2DI_FRM_PITCH[7:0]							
0x49A	M2DI_FRM_PITCH[10:8]				M2DI_FRM_WIDTH[10:8]			
0x49B	M2DI_FRM_HEIGHT[7:0]							
0x49C	M2DI_FRM_HEIGHT[9:8]							

**M2DI\_FRM\_WIDTH**      The frame width of the incoming video in pixels

**M2DI\_FRM\_PITCH**      The frame width allocated in the memory including the unused portion at the end of each line

**M2DI\_FRM\_HEIGHT**      The frame height of the incoming video in lines

## IMAGE ENHANCEMENT

Address	[7]	[6]	[5]	[4]	[3]	[2]	[1]	[0]
0x4B0	VGA_SHWIN		VGA_SHCOR					
0x4B1	VGA_OVERSHOOT				VGA_SHARP			

**VGA\_SHWIN[1]**      Sharpening filter window size selection

0      2 pixels

1      4 pixels

**VGA\_SHWIN[0]**      Sharpening filter min/max window size selection

0      2 pixels

1      4 pixels

**VGA\_SHCOR**      Sharpening Coring Setting

**VGA\_OVERSHOOT**      Sharpening overshoot setting

**VGA\_SHARP**      Sharpening gain

Address	[7]	[6]	[5]	[4]	[3]	[2]	[1]	[0]
0x4B2	VGA_BLACK							
0x4B3	VGA_Y_GAIN							
0x4B4	VGA_Y_OFFSET							
0x4B5	VGA_CR_GAIN							
0x4B6	VGA_CB_GAIN							

VGA_BLACK	The black level used for contrast control. Any incoming pixel less than this value is assume to be black. The contrast control does not amplify the black pixels.
VGA_Y_GAIN	The contrast control. A setting of 64 represents gain of 1 (neutral)
VGA_Y_OFFSET	The brightness control. A value of 128 represents offset of 0 (neutral)
VGA_CR_GAIN	Cr gain control. A value of 64 represents gain of 1 (neutral)
VGA_CB_GAIN	Cb gain control. A value of 64 represents gain of 1 (neutral)

Address	[7]	[6]	[5]	[4]	[3]	[2]	[1]	[0]
0x4B7	VGA_BKLV	VGA_WHTLV	VGA_HUEADJ					
0x4B8	VGA_BWLST[7:0]							
0x4B9	VGA_BWLEND[7:0]							
0x4BA	VGA_BWLEND[11:8]				VGA_BWLST[11:8]			
0x4BB	VGA_BWFGAIN				VGA_BWHGAIN			
0x4BC	VGA_BTILT							
0x4BD	VGA_WTILT							
0x4BE	VGA_BLIMIT							
0x4BF	VGA_WLIMIT							

VGA_HUEADJ	HUE Control
VGA_WHTLV	0 235 as white 1 255 as white
VGA_BKLV	0 0 as black 1 16 as black
VGA_BWLST	The first line of the black / white detection window for BW stretch
VGA_BWLEND	The last line of the black / white detection window for BW stretch
VGA_BWHGAIN	Tap for pixel recursive filtering before black / white line minmax detection
VGA_BWFGAIN	Tap for field recursive filtering before black / white field minmax detection
VGA_BTILT	Black Tilt point for BW stretch
VGA_WTILT	White Tilt point for BW stretch
VGA_BLIMIT	The darkest pixel value after BW stretch
VGA_WLIMIT	The brightest pixel value after BW stretch

Address	[7]	[6]	[5]	[4]	[3]	[2]	[1]	[0]
0x4C8	VGA_R_GAIN							
0x4C9	VGA_R_OFFSET							
0x4CA	VGA_G_GAIN							
0x4CB	VGA_G_OFFSET							
0x4CC	VGA_B_GAIN							
0x4CD	VGA_B_OFFSET							

VGA_R_GAIN	Red color gain control. A setting of 64 represents gain of 1 (neutral)
VGA_R_OFFSET	Red color offset control. A setting of 128 represents offset of 0 (neutral)
VGA_G_GAIN	Green color gain control. A setting of 64 represents gain of 1 (neutral)
VGA_G_OFFSET	Green color offset control. A setting of 128 represents offset of 0 (neutral)
VGA_B_GAIN	Blue color gain control. A setting of 64 represents gain of 1 (neutral)
VGA_B_OFFSET	Blue color offset control. A setting of 128 represents offset of 0 (neutral)

## Video Output

### RECORD CVBS TIMING

Address	[7]	[6]	[5]	[4]	[3]	[2]	[1]	[0]
0x228	RP_HALF_LINE[7:0]							
0x229	RP_HALF_LINE[9:8]			RP_HS_P_OS				
0x22A	RP_HS_WIDTH							

RP_HALF_LINE	This defines in number of clock cycles from VS edge to the location of field change, in case it is change in middle of a line
RP_HS_P_OS	HSYNC starting location, in number of clock cycles
RP_HS_WIDTH	HSYNC width, in number of clock cycles

Address	[7]	[6]	[5]	[4]	[3]	[2]	[1]	[0]
0x22B								RP_TOP_VS_END
0x22C								RP_BOT_VS_END
0x22D	RP_T_VS_POS							RP_TOP_VS_OS
0x22E	RP_B_VS_POS							RP_BOT_VS_OS

RP_TOP_VS_END	VSYNC trailing edge location of top field, in number of lines
RP_BOT_VS_END	VSYNC trailing edge location of bottom field, in number of lines
RP_TOP_VS_OS	VSYNC leading edge location of top field, in number of lines
RP_BOT_VS_OS	VSYNC leading edge location of bottom field, in number of lines
RP_T_VS_POS	Enable the top field vsync edge at the middle of a line
RP_B_VS_POS	Enable the bottom field vsync edge at the middle of a line

Address	[7]	[6]	[5]	[4]	[3]	[2]	[1]	[0]
0x22F			RP_HS_POL	RP_VS_POL	RP_FLD_POL	RP_VAV_POL	RP_HAV_POL	RP_656_ERRCHK

RP_HS_POL	Output HSYNC polarity control
RP_VS_POL	Output VSYNC polarity control
RP_FLD_POL	Output FIELD polarity control
RP_VAV_POL	Output VAV polarity control
RP_HAV_POL	Output HAV polarity control
RP_656_ERRCHK	Enable 656 SAV/EAV error check

## SPOT CVBS TIMING

Address	[7]	[6]	[5]	[4]	[3]	[2]	[1]	[0]
0x2B8	SP_HALF_LINE[7:0]							
0x2B9	SP_HALF_LINE[9:8]		SP_HS_P_OS					
0x2BA	SP_HS_WIDTH							

SP_HALF_LINE	This defines in number of clock cycles from VS edge to the location of field change, in case it is change in middle of a line
SP_HS_P_OS	HSYNC starting location, in number of clock cycles
SP_HS_WIDTH	HSYNC width, in number of clock cycles



Address	[7]	[6]	[5]	[4]	[3]	[2]	[1]	[0]
0x2BB	0	0	0	SP_TOP_VS_END				
0x2BC	0	0	0	SP_BOT_VS_END				
0x2BD	SP_T_VS_POS	0	0	SP_TOP_VS_OS				
0x2BE	SP_B_VS_POS	0	0	SP_BOT_VS_OS				

SP_TOP_VS_END	VSYNC trailing edge location of top field, in number of lines
SP_BOT_VS_END	VSYNC trailing edge location of bottom field, in number of lines
SP_TOP_VS_OS	VSYNC leading edge location of top field, in number of lines
SP_BOT_VS_OS	VSYNC leading edge location of bottom field, in number of lines
SP_T_VS_POS	Enable the top field vsync edge at the middle of a line.
SP_B_VS_POS	Enable the bottom field vsync edge at the middle of a line

Address	[7]	[6]	[5]	[4]	[3]	[2]	[1]	[0]
0x2BF			SP_HS_POL	SP_VS_POL	SP_FLD_POL	SP_VAV_POL	SP_HAV_POL	SP_656_ERRCHK

SP_HS_POL	Output HSYNC polarity control
SP_VS_POL	Output VSYNC polarity control
SP_FLD_POL	Output FIELD polarity control
SP_VAV_POL	Output VAV polarity control
SP_HAV_POL	Output HAV polarity control
SP_656_ERRCHK	Enable 656 SAV/EAV error check

## DISPLAY CVBS TIMING

Address	[7]	[6]	[5]	[4]	[3]	[2]	[1]	[0]
0x2C8	DP_HALF_LINE[7:0]							
0x2C9	DP_HALF_LINE[9:8]		DP_HS_P_OS					
0x2CA	DP_HS_WIDTH							

DP_HALF_LINE	This defines in number of clock cycles from VS edge to the location of field change, in case it is change in middle of a line
DP_HS_P_OS	HSYNC starting location, in number of clock cycles
DP_HS_WIDTH	HSYNC width, in number of clock cycles

Address	[7]	[6]	[5]	[4]	[3]	[2]	[1]	[0]
0x2CB								DP_TOP_VS_END
0x2CC								DP_BOT_VS_END
0x2CD	DP_T_VS_POS							DP_TOP_VS_OS
0x2CE	DP_B_VS_POS							DP_BOT_VS_OS

DP_TOP_VS_END	VSYNC trailing edge location of top field, in number of lines
DP_BOT_VS_END	VSYNC trailing edge location of bottom field, in number of lines
DP_TOP_VS_OS	VSYNC leading edge location of top field, in number of lines
DP_BOT_VS_OS	VSYNC leading edge location of bottom field, in number of lines
DP_T_VS_POS	Enable the top field vsync edge at the middle of a line.
DP_B_VS_POS	Enable the bottom field vsync edge at the middle of a line

Address	[7]	[6]	[5]	[4]	[3]	[2]	[1]	[0]
0x2CF			DP_HS_POL	DP_VS_POL	DP_FLD_POL	DP_VAV_POL	DP_HAV_POL	DP_656_ERRCHK

DP_HS_POL	Output HSYNC polarity control
DP_VS_POL	Output VSYNC polarity control
DP_FLD_POL	Output FIELD polarity control
DP_VAV_POL	Output VAV polarity control
DP_HAV_POL	Output HAV polarity control
DP_656_ERRCHK	Enable 656 SAV/EAV error check

**CVBS ENCODER CONTROL**

Address	[7]	[6]	[5]	[4]	[3]	[2]	[1]	[0]
0x2D0	VE_FSCSEL		0	VE_FLD	VE_VS	0	1	VE_PAL_NTSC

<b>VE_FSCSEL</b>	Set the sub-carrier frequency for video encoder
0	3.57954545 MHz (default)
1	4.43361875 MHz
2	3.57561149 MHz
3	3.58205625 MHz
<b>VE_FLD</b>	Define the field detection type
0	Use field from input field signal (default)
1	Detect field from combination of HSENC and VSENC signals
<b>VE_VS</b>	Define the vertical sync (VSYNC) detection type
0	Use signal from input VSYNC
1	Detect VSYNC from combination of HSENC and FLDEN
<b>VE_PAL_NTSC</b>	Define the PAL or NTSC
0	NTSC
1	PAL

Address	[7]	[6]	[5]	[4]	[3]	[2]	[1]	[0]
0x2D1	VE_HSD[9:8]		VE_FLDPOL	VE_VSPOL	VE_HSPOL	VE_PED	VE_FDRST	VE_PHALT

<b>VE_FLDPOL</b>	Control the field polarity
0	Even field is high (default)
1	Odd field is high
<b>VE_VSPOL</b>	Control the vertical sync polarity
0	Active low (default)
1	Active high
<b>VE_HSPOL</b>	Control the horizontal sync polarity
0	Active low (default)
1	Active high
<b>VE_PED</b>	Set 7.5 IRE for pedestal level
0	IRE for pedestal level
1	7.5 IRE for pedestal level (default)
<b>VE_FDRST</b>	Reset the phase alternation every 8 field
0	No reset mode (default)
1	Reset the phase alternation every 8 field
<b>VE_PHALT</b>	Set the phase alternation
0	Disable phase alternation for line-by-line (default)
1	Enable phase alternation for line-by-line

Address	[7]	[6]	[5]	[4]	[3]	[2]	[1]	[0]
0x2D1	VE_HSDDEL[9:8]		VE_FLDPOL	VE_VSPOL	VE_HSPOL	VE_PED	VE_FDRST	VE_PHALT
0x2D2	VE_HSDEL[7:0]							
0x2D3	VE_VSOFF		VE_VSDEL					

**VE\_HSDEL** Control the pixel delay of horizontal sync from active video by  $\frac{1}{2}$  pixels/Step

0 No delay  
 :  
 :  
 256 64 pixels delay (default)  
 :  
 :  
 1023 255 pixels delay

**VE\_VSDEL** Control the line delay of vertical sync from active video by 1 line/step

0 No delay  
 :  
 :  
 32 32 lines delay (default)  
 :  
 :  
 63 63 lines delay

**VE\_VSOFF** Compensate the field offset for the first active video line

0 Apply same VE\_VSDEL for odd and even field (default)  
 1 Apply (VE\_VSDEL+1) for odd and VE\_VSDEL for even field  
 2 Apply VE\_VSDEL for odd and (VE\_VSDEL + 1) for even field  
 3 Apply VE\_VSDEL for odd and (VE\_VSDEL+2) for even field

Address	[7]	[6]	[5]	[4]	[3]	[2]	[1]	[0]
0x2D4	VE_ACTIVE_VDEL							
0x2D5	VE_ACTIVE_HDEL							

**VE\_ACTIVE\_VDEL** Control the line delay of active video by 1 line/step

0 -12 lines delay  
 :  
 :  
 12 0 line delay (default)  
 :  
 :  
 25 13 lines delay

**VE\_ACTIVE\_HDEL** Control the pixel delay of active video by 1 pixel/step

0 -32 pixels delay  
 :  
 :  
 32 0 pixel delay  
 :  
 :  
 63 31 pixels delay

Address	[7]	[6]	[5]	[4]	[3]	[2]	[1]	[0]
0x2D6	0	0	0		0		VE_ACTIVE_MD	VE_CCIR_STD

**VE\_ACTIVE\_MD**                    0     Select the active delay mode for digital BT. 656 output control the active delay for both analog encoder and digital output (default)  
    1     Control the active delay for only analog encoder

**VE\_T\_656\_STD**                    Select the ITU-R BT. 656 standard format for 60 Hz system  
    0     240 lines for odd and even field  
    1     244 lines for odd and 243 lines for even field (Standard)

Address	[7]	[6]	[5]	[4]	[3]	[2]	[1]	[0]
0x2D7	0	VE_OSD_SELO	VE_SELO		VE_CBWO		VE_YBWO	
0x2D8	0	VE_OSD_SEL1	VE_SEL1		VE_CBW1		VE_YBW1	

**VE\_OSD\_SEL**                    Select video encoder output with OSD  
    1     Turn on OSD  
    0     Turn off OSD

**VE\_SEL**                            Select the source of the video encoder  
    0     Select display CVBS output  
    1     Select SPOT CVBS output  
    2     Select RECORD CVBS output  
    3     Reserved

**VE\_CBW**                            Control the chrominance bandwidth of video encoder  
    0     0.8 MHz  
    1     1.15 MHz  
    2     1.35 MHz (default)  
    3     1.35 MHz

**VE\_YBW**                            Control the luminance bandwidth of video encoder  
    0     Narrow bandwidth  
    1     Narrower bandwidth  
    2     Wide bandwidth (default)  
    3     Middle bandwidth

Address	[7]	[6]	[5]	[4]	[3]	[2]	[1]	[0]
0x2D9		VE_CBGEN1	VE_CKILL1			VE_CBGENO	VE_CKILLO	

**VE\_CBGEN**                    Enable the test pattern output  
    0     Normal operation  
    1     Internal color bar with 100% amplitude and 100% saturation

**VE\_CKILL**                    Enable the color kill function  
    0     Normal operation (default)  
    1     Color is killed

**DISPLAY CASCADE TIMING**

Address	[7]	[6]	[5]	[4]	[3]	[2]	[1]	[0]
0x508	VDOX_BT1120_SEL	VDOX_FLD_POL	VDOX_1120_CROP	VDOX_HVS_MD	VDOX_DIG_OSD_BP			DISP_CVBS_EN

DISP_CVBS_EN	1	Enable Display CVBS Path
	0	Enable display digital output (either BT1120 or 8-bit cascade)
VDOX_DIG_OSD_BP	1	Bypass the digital display path OSD
	0	Enable the OSD on the display digital output
VDOX_HVS_MD	1	Output HAV/VAV signal at the HSYNC VSYNC port
	0	Output regular HSYNC/VSYNC signal
VDOX_1120_CROP	1	BT1120 mode crop window enabled
	0	BT1120 mode crop window disabled
VDOX_FLD_POL	1	Reverse the field polarity for display digital output
	0	Do not reverse the field polarity for display digital output
VDOX_BT1120_SEL	1	Select display digital output as the BT1120 output
	0	Select display digital output as the 8-bit Cascade output

Address	[7]	[6]	[5]	[4]	[3]	[2]	[1]	[0]
0x509	VDOX_BT1120_TOP_OS[7:0]							
0x50A	VDOX_BT1120_BOT_OS[7:0]							
0x50B	VDOX_BT1120_L_OS[7:0]							
0x50C	VDOX_BT1120_R_OS[7:0]							
0x50D				VDOX_BT1120_R_OS[8]				VDOX_BT1120_BOT_OS[8]

**VDOX\_BT1120\_TOP\_OS** Top offset defining the vertical starting location of active video in the BT1120 (1920x1080) frame

**VDOX\_BT1120\_BOT\_OS** Bottom offset defining the vertical ending location of active video in the BT1120 (1920x1080) frame

**VDOX\_BT1120\_L\_OS** Left offset defining the horizontal starting location of active video in the BT1120 (1920x1080) frame

**VDOXD\_BT1120\_R\_OS** Right offset defining the horizontal ending location of active video in the BT1120 (1920x1080) frame

Address	[7]	[6]	[5]	[4]	[3]	[2]	[1]	[0]
0x50F								VDOX_VAV_ODD_OFS
0x510								VDOX_VAV_EVEN_OFS

**VDOX\_VAV\_ODD\_OFS** The line number between the beginning of the ODD field and the beginning of VAV of display digital output (BT1120 or cascade)

**VDOX\_VAV\_EVEN\_OFS** The line number between the beginning of the EVEN field and the beginning of VAV of display digital output (BT1120 or cascade)

Address	[7]	[6]	[5]	[4]	[3]	[2]	[1]	[0]
0x511	VDOX_VS_POL	VDOX_HS_POL	VDOX_VS_ETP_EN	VDOX_VS_ELP_EN	VDOX_VS_OTP_EN	VDOX_VS_OLP_EN		

**VDOX\_VS\_POL** Select the VS polarity of display digital output.  
**1** Low active  
**0** High active

**VDOX\_HS\_POL** Select the HS polarity of display digital output  
**1** Low active  
**0** High active

**VDOX\_VS\_ETP\_EN** Enable the pixel offset of even field VS trailing edge relative to HS specified with VDOX\_VS\_POFS

**VDOX\_VS\_ELP\_EN** Enable the pixel offset of even field VS leading edge relative to HS specified with VDOX\_VS\_POFS

**VDOX\_VS\_OTP\_EN** Enable the pixel offset of odd field VS trailing edge relative to HS specified with VDOX\_VS\_POFS

**VDOX\_VS\_OLP\_EN** Enable the pixel offset of odd field VS leading edge relative to HS specified with VDOX\_VS\_POFS

Address	[7]	[6]	[5]	[4]	[3]	[2]	[1]	[0]
0x512	VDOX_VS_POFS[11:8]				VDOX_VSYNC_WIDTH			
0x513	VDOX_VS_POFS[7:0]							

**VDOX\_VS\_POFS** The pixel offset of VS edge relative to HS for the display digital output timing

**VDOX\_VSYNC\_WIDTH** The VSYNC width in unit of lines for the display digital output timing

Address	[7]	[6]	[5]	[4]	[3]	[2]	[1]	[0]
0x514	VDOX_VS_E_LOFS				VDOX_VS_O_LOFS			

**VDOX\_VS\_E\_LOFS** The even field line offset of the VS relative to the edge of field change for the display digital output timing

**VDOX\_VS\_O\_LOFS** The odd field line offset of the VS relative to the edge of field change for the display digital output timing

Address	[7]	[6]	[5]	[4]	[3]	[2]	[1]	[0]
0x515							VDOX_HS_WIDTH[8]	0
0x516	VDOX_HS_WIDTH[7:0]							
0x517	0							

**VDOX\_HS\_WIDTH** The HSYNC Width in number of pixels for the display digital output timing

Address	[7]	[6]	[5]	[4]	[3]	[2]	[1]	[0]
0x518	VDOX_HACTIVE[11:8]						VDOX_VACTIVE[9:8]	
0x519	VDOX_VACTIVE[7:0]							
0x51A	VDOX_HACTIVE[7:0]							

**VDOX\_HACTIVE** The active pixels per line for the display digital output timing

**VDOX\_VACTIVE** The active lines per field for the display digital output timing

Address	[7]	[6]	[5]	[4]	[3]	[2]	[1]	[0]
0x51B			VDOX_OVT[9:8]				VDOX_EVT[9:8]	
0x51C	VDOX_EVT[7:0]							
0x51D	VDOX_OVT[7:0]							

**VDOX\_EVT** The total line number of even field including vertical blanking for the display digital output timing

**VDOX\_OVT** The total line number of odd field including vertical blanking for the display digital output timing

Address	[7]	[6]	[5]	[4]	[3]	[2]	[1]	[0]
0x51E					VDOX_HT [11:8]			
0x51F	VDOX_HT [7:0]							

**VDOX\_HT** The total pixel number per line including horizontal blanking for the display digital output timing



**DISPLAY VGA TIMING**

Address	[7]	[6]	[5]	[4]	[3]	[2]	[1]	[0]
0x4D0	VGA_HTOTAL[7:0]							
0x4D1	VGA_VTOTAL[7:0]							
0x4D2	VGA_VTOTAL[10:8]				VGA_HTOTAL[10:8]			
0x4D3	VGA_HSTART[7:0]							
0x4D4	VGA_HACTIVE[7:0]							
0x4D5	VGA_HACTIVE[10:8]				VGA_HSTART[10:8]			
0x4D6	VGA_VSTART[7:0]							
0x4D7	VGA_VACTIVE[7:0]							
0x4D8	VGA_VACTIVE[10:8]				VGA_VSTART[10:8]			
0x4D9	VGA_TRACK_EN	VGA_AUTO_ADJ		VGA_LOCK_EN	VGA_TIM_WIN			

**VGA\_HTOTAL** VGA pixel size per line, including horizontal blanking. Note the following condition needs to be met.

$$\text{VGA\_HTOTAL} - \text{VGA\_HSTART} - \text{VGA\_HACTIVE} > 6$$

**VGA\_VTOTAL** VGA line size per frame, including the vertical blanking. Note the following condition needs to be met.

$$\text{VGA\_VTOTAL} - \text{VGA\_VSTART} - \text{VGA\_VACTIVE} > 2$$

**VGA\_HSTART** VGA active pixel starting location relative to the leading edge of HSYNC, in # of pixels.

$$\text{VGA\_HSTART} = \text{VGA\_HS\_WIDTH} + \text{H Back Porch} - 6$$

**VGA\_HACTIVE** VGA active pixel width per line, in # of pixels

**VGA\_VSTART** VGA active line starting location relative to the leading edge of VSYNC, in # of lines

$$\text{VGA\_VSTART} = \text{VGA\_VS\_WIDTH} + \text{V Back Porch}$$

**VGA\_VACTIVE** VGA active line height per frame, in # of lines

**VGA\_TRACK\_EN** Enable frame tracking.  
 0 Does not do frame tracking. Always use free running control  
 1 Enable frame tracking

**VGA\_AUTO\_ADJ** 0 Hardware does not adjust to do frame tracking  
 1 Hardware adjust the configuration to do frame tracking

**VGA\_LOCK\_EN** 0 Free running  
 1 Lock to incoming video timing

**VGA\_TIM\_WIN** In frame tracking, this parameter specifies the maximum number of lines inserted in the vertical blanking to track the incoming frame

Address	[7]	[6]	[5]	[4]	[3]	[2]	[1]	[0]
0x4DA							VGA_HS_POL	VGA_VS_POL
0x4DB	VGA_HS_WIDTH							
0x4DC	VGA_VS_WIDTH							

VGA\_VS\_POL            1     Negative (Low active)  
                              0     Positive (High active)

VGA\_HS\_POL            1     Negative (Low active)  
                              0     Positive (High active)

VGA\_HS\_WIDTH         VGA HSYNC width in # of pixels

VGA\_VS\_WIDTH         VGA VSYNC height in # of lines

### TFT PANEL CONTROL

Address	[7]	[6]	[5]	[4]	[3]	[2]	[1]	[0]
0x4E2	FP_PX_MODE	FP_DE_AH	FP_HS_AH	FP_VS_AH	FP_CK_AH			
0x4E3			FP_SEL_LG		FP_SIG_OFF	FP_CKTPS		

FP\_PX\_MODE            1     Set dual channel LVDS output  
                              0     Set single channel LVDS output

FP\_DE\_AH               1     Panel DE signal active high  
                              0     Panel DE signal active low

FP\_HS\_AH               1     Panel HS signal active high  
                              0     Panel HS signal active low

FP\_VS\_AH               1     Panel VS signal active high  
                              0     Panel VS signal active low

FP\_CK\_AH               Reverse the FPCLK polarity  
                              1     Data is sampled at the falling edge  
                              0     Data is sampled at the rising edge

FP\_SEL\_LG              0     Select the LVDS mapping of the Samsung type  
                              1     Select the LVDS mapping of the LG type  
                              2     Reserved  
                              3     Reserved

FP\_SIG\_OFF             0     Do not turn off the panel  
                              1     Turn off the panel

FP\_CKTPS               Reserved

Address	[7]	[6]	[5]	[4]	[3]	[2]	[1]	[0]
0x4E4	FP_PWR_CLK_DV							
0x4E5	FP_CLK_PWDN	FP_CLKSEL			FP_MAN_PWR	FP_EDPMS	FP_PCR	

**FP\_PWR\_CLK\_DV** MSB of the internal 23 bit divide down counter. The 27 MHz clock is divided by this counter to serve as the clock for Power State Transition timer.

**FP\_CLK\_PWDN** 1 Force the internal panel clock to power down

**FP\_CLKSEL** Default 1

**FP\_MAN\_PWR** Show current power management state. These power states determine the states of FPPWC, FPBIAS, and FP Interfaces such as FPVS, FPDE, FPCLK and all data signals.

	FPPWC	FPBIAS	FP Interfaces
00: off	"0"	"0"	"0"
01: Standby	"1"	"0"	"0"
10: Suspend	"1"	"0"	"1" or "0"
11: On	"1"	"1"	"1" or "0"

The transition between power states does not occur right away. It takes place after the timer expiration defined in 0x4E6 ~ 0x4E8

**FP\_EDPMS** If FP\_MAN\_PWR is "0" and FP\_EDPMS is "1", it enables auto power sequencing.

VSYNC loss & HSYNC loss	Off
VSYNC loss & HSYNC active	Standby
VSYNC active & HSYNC loss	Suspend
VSYNC active & HSYNC active	On

**FP\_PCR** Force the power state to sequence to this state, and stay in this state

0	Off
1	Standby
2	Suspend
3	On

Address	[7]	[6]	[5]	[4]	[3]	[2]	[1]	[0]
0x4E6	FP_ITV12				FP_ITV01			
0x4E7	FP_ITV32				FP_ITV23			
0x4E8	FP_ITV21				FP_ITV10			
0x4E9	FP_PWM_CLK_SEL	FP_PWM						
0x4EB								FP_PWM_AL

FP_ITV01	Timer counts for On state to Suspend state transition
FP_ITV12	Timer counts for Suspend state to Standby state transition
FP_ITV23	Timer counts for Standby state to Power Off state
FP_ITV32	Timer counts for Power Off state to Standby state
FP_ITV10	Timer count for Suspend state to On State
FP_ITV21	Timer count for Standby state to Suspend state
FP_PWM_CLK_SEL	1 PWM clock set to 27 MHz 0 PWM clock set to 13.5 MHz
FP_PWM	Pulse width of PWM is FP_PWM + 1
FP_PWM_AL	PWM Output Polarity 1 Reverse PWM signal output polarity 0 Do not reverse PWM signal output polarity

Address	[7]	[6]	[5]	[4]	[3]	[2]	[1]	[0]
0xE40	LVDS_LP_SEL		LVDS_CP_SEL			LVDS_EN	LVDS_FAB_TEST	LVDS_LCD_TEST
0xE41	LVDS_SWAP_CH	LVDS_9BIT_DC	LVDS_NS_SEL	LVDS_DC_BAL	LVDS_BITPERPIXEL		LVDS_REV_DATA	LVDS_SEL_LD
0xE42			LVDS_REV_DCB	LVDS_DCB_POL		LVDS_MAP_SEL		
0xE43						LVDS_VOS_SEL	LVDS_I_SEL	

LVDS_LP_SEL		Default 0
LVDS_CP_SEL		Default 0
LVDS_EN	0	LVDS Disabled
	1	LVDS Enabled
LVDS_FAB_TEST	0	Normal Operation
	1	LVDS Test Mode
LVDS_LCD_TEST	0	Normal Operation
	1	LCD Panel Test Mode
LVDS_SWAP_CH	1	Swap LVDS channel 0 and 1
	0	Do not swap LVDS channel 0 and 1
LVDS_9BIT_DC	0	Select 7 cycle DC balance, as used in most National chip
	1	Select 9 cycle DC balance, as used in MAXIM chip
LVDS_NS_SEL	0	Output data mapping same as Maxim or THine LVDS interface protocol
	1	Output data mapping same as National interface protocol
LVDS_DC_BAL	1	DC Balance Enable
	0	DC Balance Disable
LVDS_BITPERPIXEL	0	6 bit data output
	1	8 bit data output
	2	10 bit data output
LVDS_REV_DATA	0	Normal data output format
	1	Reverse data output format
LVDS_SEL_LD		Load/Shift signal polarity selection
	0	Active low
	1	Active high
LVDS_REV_DCB	1	Reverse DC balance bit order
LVDS_DCB_POL	1	Reverse DC balance polarity
LVDS_MAP_SEL		Change the mapping location of DE, VSYNC and HSYNC signals
	000	{DE, VSYNC, HSYNC }
	001	{VSYNC, HSYNC, DE }
	010	{HSYNC, DE, VSYNC }
	100	{DE, HSYNC, VSYNC }
	101	{HSYNC, VSYNC, DE }
	110	{VSYNC, DE, HSYNC }

LVDS_VOS_SEL	LVDS Driver Voltage Offset Select
LVDS_I_SEL	LVDS Driver Output Swing Select

## OSG

### OSG BITMAP WRITE / MOVE

Address	[7]	[6]	[5]	[4]	[3]	[2]	[1]	[0]
0x640	OSG_MEM_WIDTH							

**OSG\_MEM\_WIDTH** The OSG memory structure width in units of 64 pixels (128 bytes)

Address	[7]	[6]	[5]	[4]	[3]	[2]	[1]	[0]
0x641	OSG_WRBASE_ADDR							

#### OSG\_WRBASE\_ADDR

The base address used for writing data into OSG memory space. This base address can be set statically to treat all the OSG memory space into a big one, or it can be set dynamically to match each of the OSG base address at the write side. The unit is in 64 Kbytes.

The DDR address generated from this register is {1'b1, OSG\_WRBASE\_ADDR[7:0], 16'h0}

Address	[7]	[6]	[5]	[4]	[3]	[2]	[1]	[0]
0x642	0		OSG_COLR_CON	0	1	1	OSG_OPMODE	

<b>OSG_COLR_CON</b>	<b>1</b>	Turn on color conversion before writing into the memory. There is a 4-entry color conversion table used to match with the pixel value. If it matches, the pixel is converted to a specified corresponding output pixel value.
	<b>0</b>	Turn off the color conversion function
<b>OSG_OPMODE</b>	<b>0</b>	Bitmap Write Mode – CPU fill all the pixel bitmaps
	<b>1</b>	Block Move Mode – Move one block of memory content from one location to another location
	<b>2</b>	Block Fill Mode
	<b>3</b>	Reserved

Address	[7]	[6]	[5]	[4]	[3]	[2]	[1]	[0]
0x645		OSG_SRC_SH[10:8]				OSG_SRC_SV[10:8]		
0x646	OSG_SRC_SV[7:0]							
0x647	OSG_SRC_SH[7:0]							
0x648		OSG_DST_EH[10:8]				OSG_DST_EV[10:8]		
0x649	OSG_DST_EV[7:0]							
0x64A	OSG_DST_EH[7:0]							
0x64B		OSG_DST_SH[10:8]				OSG_DST_SV[10:8]		
0x64C	OSG_DST_SV[7:0]							
0x64D	OSG_DST_SH[7:0]							

<b>OSG_SRC_SV</b>	The start line of the source block
<b>OSG_SRC_SH</b>	The starting pixel of the source block
<b>OSG_DST_EV</b>	The end line of the destination block
<b>OSG_DST_EH</b>	The end pixel of the destination block
<b>OSG_DST_SV</b>	The starting line of the destination block
<b>OSG_DST_SH</b>	The starting pixel of the destination block

Address	[7]	[6]	[5]	[4]	[3]	[2]	[1]	[0]
0x64E	SELOSG				0	OSG_INDRD	OSG_INDWR	0

<b>OSG_INDWR</b>	Write 1 to start indirect write command for on-chip table selected by OSG_SELOSG. Write only
<b>OSG_INDRD</b>	Write 1 to start indirect read command from on-chip table selected by OSG_SELOSG. Write only
<b>OSG_SELOSG</b>	0: Color conversion table. Others: reserved.

Address	[7]	[6]	[5]	[4]	[3]	[2]	[1]	[0]
0x64F		OSG_IDLE	OSG_BMWR_BUSY					OSG_OP_START

- OSG\_OP\_START** Command bit to start the BLOCK MOVE, BLOCK FILL, or BITMAP WRITE function. Self clear after done.  
This bit can be used as status bit for whether the OSG is ready for a new operation. If it is 0, means the previous operation is done.  
Note: do not write 0 to this bit. It may cause unexpected result.
- OSG\_BMWR\_BUSY** Read only flag to specify whether the BITMAP WRITE fifo has 256 byte space available to write. If this bit is 0, the MCU can feel free to write up to 256 bytes without checking this bit again.
- OSG\_IDLE** Read only flag to specify OSG state machine is idle. This bit is usually the opposite of the OSG\_OP\_START (0x64F[0]), unless OSG\_OP\_START was set at incorrect time during OSG\_IDLE is not 1.
- 0 OSG operation is in progress  
1 OSG operation is idle

Address	[7]	[6]	[5]	[4]	[3]	[2]	[1]	[0]
0x650	OSG_IND_ADDR							

- OSG\_IND\_ADDR** The indirect access address used to access the internal tables.

Address	[7]	[6]	[5]	[4]	[3]	[2]	[1]	[0]
0x651	OSG_IND_WRDATA							

- OSG\_IND\_WRDATA** The indirect write data for writing the color table.

Address	[7]	[6]	[5]	[4]	[3]	[2]	[1]	[0]
0x652	OSG_UP_DATA[15:0] or OSG_UP_DATA[7:0]							

- OSG\_UP\_DATA** The BITMAP WRITE data register. Note that in the 16-bit data bus mode, this address is used to write 16 bits, instead of 8 bits.

Address	[7]	[6]	[5]	[4]	[3]	[2]	[1]	[0]
0x654	OSG_FILL_COLR[7:0] (Y2)							
0x655	OSG_FILL_COLR[15:8] (Cr)							
0x656	OSG_FILL_COLR[23:16] (Y1)							
0x657	OSG_FILL_COLR[31:24] (Cb)							

- OSG\_FILL\_COLR[31:24]** U pixel value for block fill  
**OSG\_FILL\_COLR[23:16]** Y1 pixel value for block fill  
**OSG\_FILL\_COLR[15:8]** V pixel value for block fill  
**OSG\_FILL\_COLR[7:0]** Y2 pixel value for block fill



Address	[7]	[6]	[5]	[4]	[3]	[2]	[1]	[0]
0x658	OSG_RLC_EN			OSG_RLC_32B				OSG_RLC_CNT

<b>OSG_RLC_EN</b>		Enable proprietary hardware RLC decompression while uploading the bitmap into the OSG buffer. With this feature turned on, the uploading bitmap from MCU through the host interface is in RLC compressed format. The RLC compressed result is decompressed by the hardware automatically. This reduces the bandwidth consumption on the host interface.
<b>OSG_RLC_32B</b>	1 0	Use 32 bit data for compression pattern match Use 16 bit data for compression pattern match
<b>OSG_RLC_CNT</b>		Indicate how many bits are used for the repetition count. 0 The repetition count is 16 bits 1 - 15 The repetition count is 1 - 15 bits

The proprietary compression format is as follows:

F, D/C, F, D/C, .....

<b>Where F (1 bit):</b>	0 : indicate the following is pixel data 1 : indicate the following is repetition count
<b>D :</b>	Pixel Data in either 16 bits or 32 bits, as specified by OSG_RLC_32B)
<b>C :</b>	Repetition count (how many times the D data is repeated. The number of bits of this repetition count is controlled by the OSG_RLC_CNT.

Note: count of 0 means 2\*\*N repetition, where N is OSG\_RLC\_CNT

## OSD BITMAP READ

0xm21, 0xm30 ~ 0xm3F, 0xm64 ~ 0xm8F are used to control the read side of the 5 OSDs.

m: 5 – Display VGA OSD

m: 6 – Display CVBS OSD

m: 7 – Record 0 OSD

m: 8 – Record 1 OSD

m: 9 – SPOT OSD

Address	[7]	[6]	[5]	[4]	[3]	[2]	[1]	[0]
0x521								
0x621								
0x721	0	0					OSD_FLD_POL	OSD_VSYNC_POL
0x821								
0x921								

OSD\_FLD\_POL

The Polarity control for the OSD to interpret the field signal

OSD\_VSYNC\_POL

The polarity control for the OSD to interpret the VS when signal

Address	[7]	[6]	[5]	[4]	[3]	[2]	[1]	[0]
0x530 0x630 0x730 0x830 0x930								OSD_BLINK_EN
0x531 0x631 0x731 9x831 0x931	OSD_TEST				OSD_WINSEL[7:0]			

**OSD\_BLINK\_EN** Enable blinking

**OSD\_TEST** OSD Test pattern. For internal use only

**OSD\_WINSEL[n]** Selects which window to configure. This is used with registers 0xm35, 0xm37 ~ 0xm3F.  
 0 ~ 7 Sub-windows  
 8 Main Window

Address	[7]	[6]	[5]	[4]	[3]	[2]	[1]	[0]
0x532 0x632 0x732 0x832 0x932	OSD_GLOBAL_ALPHA1 (Main Window)							
0x533 0x633 0x733 0x833 0x933	OSD_GLOBAL_ALPHA2 (Sub Windows)							

**OSD\_GLOBAL\_ALPHA1** The alpha value for main window

**OSD\_GLOBAL\_ALPHA2** The alpha value for all sub-windows

Address	[7]	[6]	[5]	[4]	[3]	[2]	[1]	[0]
0x534								
0x634								
0x734	0	0	OSD_BLEND_OPT	OSD_WINSUB_ON	OSD_WINMAIN_ON	OSD_P_ALPHA	OSD_MODE[1]	OSD_MODE[0]
0x834								
0x934								

<b>OSD_BLEND_OPT</b>	Decide whether single window OSD layer on top or multi-window OSD layer on top when blending
<b>OSD_WINSUB_ON</b>	Turn on sub-window OSD. Each individual sub-window is enabled by OSD_WIN_EN in 0xm35
<b>OSD_WINMAIN_ON</b>	Turn on the main window OSD
<b>OSD_P_ALPHA</b>	(reserved)
<b>OSD_MODE[1:0]</b>	For VGA OSD(0x534) 00: 422 UYVY format 01: 565 UYV format 11: 565 RGB format For other OSD (0x634/0x734/0x834/0x934) Always 422 UYVY format

Address	[7]	[6]	[5]	[4]	[3]	[2]	[1]	[0]
0x535 0x635 0x735 0x835 0x935	OSD_BLINK_TIME		OSD_WINSWITCH	OSD_WINSET			OSD_WIN_EN	

- OSD\_BLINK\_TIME** Enable blinking of the window specified by OSD\_WINSEL in 0xm31. This bit is written into the corresponding window when OSD\_WINSET is set to 1.
- 0 blink every 8 VSYNC
  - 1 blink every 16 VSYNC
  - 2 blink every 32 VSYNC
  - 3 blink every 64 VSYNC
- OSD\_WINSWITCH** Enable the dynamic field based OSD switching for record / SPOT OSD
- OSD\_WINSET** Write command to write to one of the 9 windows configuration registers. This bit is not self cleared. It requires a clear before setting to 1 again.
- OSD\_WIN\_EN** Enable the window specified by OSD\_WINSEL in 0xm31. This bit is written into the corresponding window when the OSD\_WINSET is set to 1.

Address	[7]	[6]	[5]	[4]	[3]	[2]	[1]	[0]
0x536 0x636 0x736 0x836 0x936	OSD_RDBASE_ADDR							

**OSD\_RDBASE\_ADDR** The base address of the current OSD. Each OSD can have its own base address. This address is in unit of 64 KB. The derived DDR address will be {1'b1, OSD\_RDBASE\_ADDR, 16'h0000 }

Address	[7]	[6]	[5]	[4]	[3]	[2]	[1]	[0]
0x537 0x637 0x737 0x837 0x937	OSD_SRC_SH[11:8]				OSD_SRC_SV[11:8]			
0x538 0x638 0x738 0x838 0x938	OSD_SRC_SV[7:0]							
0x539 0x639 0x739 0x839 0x939	OSD_SRC_SH[7:0]							
0x53A 0x63A 0x73A 0x83A 0x93A	OSD_DST_EH[11:8]				OSD_DST_EV[11:8]			
0x53B 0x63B 0x73B 0x83B 0x93B	OSD_DST_EV[7:0]							
0x53C 0x63C 0x73C 0x83C 0x93C	OSD_DST_EH[7:0]							
0x53D 0x63D 0x73D 0x83D 0x93D	OSD_DST_SH[11:8]				OSD_DST_SV[11:8]			
0x53E 0x63E 0x73E 0x83E 0x93E	OSD_DST_SV[7:0]							
0x53F 0x63F 0x73F 0x83F 0x93F	OSD_DST_SH[7:0]							

The following register setting are saved into the corresponding OSD window specified by OSD\_WINSEL in 0xm31 when the OSD\_WINSET bit is set to 1.

**OSD\_SRC\_SV** Starting line of the source block in the OSD memory  
**OSD\_SRC\_SH** Starting pixel of the source block in the OSD memory  
**OSD\_DST\_EV** Ending line of the OSD on the destination video stream

- OSD\_DST\_EH**                      End pixel location of the **OSD** on the destination video stream.  
This should be the starting location **OSD\_DST\_SH** + **OSD\_WIDTH**.
- OSD\_DST\_SV**                      Starting line of the **OSD** on the destination video stream
- OSD\_DST\_SH**                      Starting pixel location of the **OSD** on the destination video stream.

**1D BOX CONTROL**

Address	[7]	[6]	[5]	[4]	[3]	[2]	[1]	[0]
0x564	BOX1D_ALPHA1				BOX1D_ALPHA0			
0x664								
0x764								
0x864								
0x964								

- BOX1D\_ALPHA0**                      The alpha value for the 6 **1D**BOXs below the bitmap **OSG** layer (**1D** box 2 ~ 7)
- BOX1D\_ALPHA1**                      The alpha value for the 2 **1D**BOXs above the bitmap **OSG** layer (**1D** box 0 ~ 1)

Address	[7]	[6]	[5]	[4]	[3]	[2]	[1]	[0]
0x566 0x666 0x766 0x866 0x966	MOSAIC_COLOR_SEL1				MOSAIC_COLOR_SELO			

**MOSAIC\_COLOR\_SELO**

Mosaic color selection for the 6 1D Boxes below the bitmap OSG layer

**MOSAIC\_COLOR\_SEL1**

Mosaic color selection for the 2 1D Boxes above the bitmap OSG layer

- 0 White (75% Amplitude 100% Saturation)
- 1 Yellow (75% Amplitude 100% Saturation)
- 2 Cyan (75 % Amplitude 100 Saturation)
- 3 Green (75% Amplitude 100% Saturation)
- 4 Magenta (75% Amplitude 100% Saturation)
- 5 Red (75% Amplitude 100% Saturation)
- 6 Blue (75% Amplitude 100% Saturation)
- 7 0% Black
- 8 100% White
- 9 50% Gray
- 10 25% Gray
- 11 Blue (75% Amplitude 75% Saturation)
- 12 Defined by CLUT0 in 0xm78, 0xm7C, 0xm80
- 13 Defined by CLUT1 in 0xm79, 0xm7D, 0xm81
- 14 Defined by CLUT2 in 0xm7A, 0xm7E, 0xm82
- 15 Defined by CLUT3 in 0xm7B, 0xm7F, 0xm83



Address	[7]	[6]	[5]	[4]	[3]	[2]	[1]	[0]
0x567 0x667 0x767 0x867 0x967	BOX1D_EN							

- BOX1D\_EN**
- [1] Enable the upper layer with 2 Single Boxes (1D Box 0 ~ 1)
  - [0] Enable the lower layer with 6 Single Boxes (1D box 2 ~ 7)

Address	[7]	[6]	[5]	[4]	[3]	[2]	[1]	[0]
0x568 0x668 0x768 0x868 0x968					MOSAIC_EN	BOX1D_MIX_EN	BOX1D_BDR_EN	BOX1D_INT_EN
0x569 0x669 0x769 0x869 0x969			BOX1D_BDR_COLR		BOX1D_COLR			
0x56A 0x66A 0x76A 0x86A 0x96A			BOX1D_VT[9:8]			BOX1D_HL[10:8]		
0x56B 0x66B 0x76B 0x86B 0x96B	BOX1D_HL[7:0]							
0x56C 0x66C 0x76C 0x86C 0x96C	BOX1D_VT[7:0]							
0x56D 0x66D 0x76D 0x86D 0x96D			BOX1D_VW[9:8]			BOX1D_HW[10:8]		
0x56E 0x66E 0x76E 0x86E 0x96E	BOX1D_HW[7:0]							
0x56F 0x66F 0x76F 0x86F 0x96F	BOX1D_VW[7:0]							

Register 0xm68 ~ 0xm6F are used to control 8 sets of 1D-boxes. In order to access the 1D box to control, use MDCH\_SEL in 0xm76 to enable the corresponding bit before accessing these registers.

MOSAIC_EN[m]	Turn on the MOSAIC pattern in the 1D Box.
BOX1D_MIX_EN	Transparent blending enable
BOX1D_BDR_EN	Enable showing the border line
BOX1D_INT_EN	Enable showing the interior pixel color
BOX1D_BDR_COLR	Define the box boundary color for each box 0 0% White (Default) 1 25% White 2 50% White 3 75% White
BOX1D_COLR	Define the interior pixel colors 0 White (75% Amplitude 100% Saturation) 1 Yellow (75% Amplitude 100% Saturation) 2 Cyan (75% Amplitude 100% Saturation) 3 Green (75% Amplitude 100% Saturation)

4	Magenta (75% Amplitude 100% Saturation)
5	Red (75% Amplitude 100% Saturation)
6	Blue (75% Amplitude 100% Saturation)
7	0% Black
8	100% White
9	50% Gray
10	25% Gray
11	Blue (75% Amplitude 75% Saturation)
12	Defined by CLUT0 in 0xm78, 0xm7C, 0xm80
13	Defined by CLUT1 in 0xm79, 0xm7D, 0xm81
14	Defined by CLUT2 in 0xm7A, 0xm7E, 0xm82
15	Defined by CLUT3 in 0xm7B, 0xm7F, 0xm83

**BOX1D\_HL** Define the horizontal left location of box.

0	Left end (default)
:	:
1439	Right end

**BOX1D\_VT** Define the vertical top location of box.

0	Vertical top (default)
:	:
899	Vertical bottom

**BOX1D\_HW** Define the horizontal size of box.

0	1 Pixel width (default)
:	:
1439	1440 Pixels width

**BOX1D\_VW** Define the vertical size of box.

0	1 Lines height (default)
:	:
899	900 Lines height

**2D BOX CONTROL**

Address	[7]	[6]	[5]	[4]	[3]	[2]	[1]	[0]
0x575 0x675 0x775 0x875 0x975	MDBOX_EN					MD_BND_MERG	MDBOX_ALPHA	

- MDBOX\_EN** Enable the Motion 2D Box function
- MD\_BND\_MERG** Turn on the 2D Box merge if two adjacent box are both on
- MDBOX\_ALPHA** Select the alpha blending mode for 2D arrayed Box
- |   |               |
|---|---------------|
| 0 | 50% (default) |
| 1 | 50%           |
| 2 | 75%           |
| 3 | 25%           |

Address	[7]	[6]	[5]	[4]	[3]	[2]	[1]	[0]
0x576 0x676 0x776 0x876 0x976	MDCH_SEL							

- MDCH\_SEL** Select one of the 8 1DBOXs to configure using 0xm68 ~ 0xm6F or one of the 8 Motion 2D Boxes to configure using 0xm84 ~ 0xm8F.

Address	[7]	[6]	[5]	[4]	[3]	[2]	[1]	[0]
0x578 0x678 0x778 0x878 0x978	MD_CLUT0_Y							
0x579 0x679 0x779 0x879 0x979	MD_CLUT1_Y							
0x57A 0x67A 0x77A 0x87A 0x97A	MD_CLUT2_Y							
0x57B 0x67B 0x77B 0x87B 0x97B	MD_CLUT3_Y							
0x57C 0x67C 0x77C 0x87C 0x97C	MD_CLUT0_CB							
0x57D 0x67D 0x77D 0x87D 0x97D	MD_CLUT1_CB							
0x57E 0x67E 0x77E 0x87E	MD_CLUT2_CB							

Address	[7]	[6]	[5]	[4]	[3]	[2]	[1]	[0]
0x97E								
0x57F 0x67F 0x77F 0x87F 0x97F								MD_CLUT3_CB
0x580 0x680 0x780 0x880 0x980								MD_CLUT0_CR
0x581 0x681 0x781 0x881 0x981								MD_CLUT1_CR
0x582 0x682 0x782 0x882 0x982								MD_CLUT2_CR
0x583 0x683 0x783 0x883 0x983								MD_CLUT3_CR

**MD\_CLUTx\_Y**                      Y component for user defined color 0 (default : 0)

**MD\_CLUTx\_CB**                    Cb component for user defined color 0 (default : 0)

**MD\_CLUTx\_CR**                    Cr component for user defined color 0 (default : 0)

Address	[7]	[6]	[5]	[4]	[3]	[2]	[1]	[0]
0x584 0x684 0x784 0x884 0x984					MDBOX_MODE			
0x585 0x685 0x785 0x885 0x985	MDDT_EN	MDMASK_EN	MDBOX_VINV	MDBOX_HINV	MDBOX_MIX	MDCUR_EN		MDBOXm_EN
0x586 0x686 0x786 0x886 0x986	MDDT_COLR			MDMASK_COLR				
0x587 0x687 0x787 0x887 0x987		MDBOX_VOS[10:8]				MDBOX_HOS[10:8]		
0x588 0x688 0x788 0x888 0x988	MDBOX_HOS[7:0]							
0x589 0x689 0x789 0x889 0x989	MDBOX_VOS[7:0]							
0x58A 0x68A 0x78A 0x88A 0x98A		MDBOX_VW[10:8]				MDBOX_HW[10:8]		
0x58B 0x68B 0x78B 0x88B 0x98B	MDBOX_HW[7:0]							
0x58C 0x68C 0x78C 0x88C 0x98C	MDBOX_VW[7:0]							
0x58D 0x68D 0x78D 0x88D 0x98D						MDBOX_BNDEN	MD_BNDRY_COLR	
0x58E 0x68E 0x78E 0x88E 0x98E	MDCUR_HPOS				MDCUR_VPOS			
0x58F 0x68F 0x78F 0x88F 0x98F	MDBOX_HCELL				MDBOX_VCELL			

Register 0xm84 ~ 0xm8F are used to control 8 sets of 2D boxes. In order to select the specific 2D box to control, use MDCH\_SEL in 0xm76 to enable the corresponding bit before accessing these registers.

**MDBOX\_MODE**

Define the operation mode of 2D arrayed box.

0 Table mode (default)

1 Motion display mode

<b>MDDET_EN</b>	<p>Enable the motion cell display when the corresponding mask bit is 0</p> <p>When MDBOX_MODE = "0"</p> <p>0     Disable the detection plane of 2D arrayed box (default)</p> <p>1     Enable the detection cell of 2D arrayed box</p> <p>When MDBOX_MODE = "1"</p> <p>0     Display the motion detection result with inner boundary</p> <p>1     Display the motion detection result with whole cell area</p>
<b>MDMASK_EN</b>	<p>Enable the mask plane of 2D arrayed box</p> <p>0     Disable the mask plane of 2D arrayed box (default)</p> <p>1     Enable the mask plane of 2D arrayed box</p>
<b>MDBOX_VINV</b>	<p>Enable the vertical mirroring for 2D arrayed box.</p> <p>0     Normal operation (default)</p> <p>1     Enable the vertical mirroring</p>
<b>MDBOX_HINV</b>	<p>Enable the horizontal mirroring for 2D arrayed box.</p> <p>0     Normal operation (default)</p> <p>1     Enable the horizontal mirroring</p>
<b>MDBOX_MIX</b>	<p>Enable the alpha blending for 2D arrayed box plane with video data.</p> <p>0     Disable the alpha blending (default)</p> <p>1     Enable the alpha blending with MDBOX_ALPHA setting (0x575)</p>
<b>MDCUR_EN</b>	<p>Used to change the color of a cell to indicate the cell where the cursor is located</p>
<b>MDBOXm_EN</b>	<p>Enable the 2Dbox specified by 0xm76</p> <p>0     Disable the 2D box (default)</p> <p>1     Enable the 2D box</p>
<b>MDMASK_COLR</b>	<p>Define the color of Mask plane in 2D arrayed box. (default = 0)</p>
<b>MDDET_COLR</b>	<p>Define the color of Detection plane in 2D arrayed box. (default = 0)</p> <p>0     White (75% Amplitude 100% Saturation)</p> <p>1     Yellow (75% Amplitude 100% Saturation)</p> <p>2     Cyan (75 % Amplitude 100 Saturation)</p> <p>3     Green (75% Amplitude 100% Saturation)</p> <p>4     Magenta (75% Amplitude 100% Saturation)</p> <p>5     Red (75% Amplitude 100% Saturation)</p> <p>6     Blue (75% Amplitude 100% Saturation)</p> <p>7     0% Black</p> <p>8     100% White</p> <p>9     50% Gray</p> <p>10    25% Gray</p> <p>11    Blue (75% Amplitude 75% Saturation)</p> <p>12    Defined by CLUT0</p> <p>13    Defined by CLUT1</p> <p>14    Defined by CLUT2</p> <p>15    Defined by CLUT3</p>
<b>MDBOX_VOS</b>	<p>Define the vertical top location of 2D arrayed box.</p>

	0	Vertical top end (default)
	:	:
	900	Vertical bottom end
<b>MDBOX_HOS</b>		Define the horizontal left location of 2D arrayed box.
	0	Horizontal left end (default)
	:	:
	720	Horizontal right end
<b>MDBOX_VW</b>		Define the vertical size of 2D arrayed box.
	0	0 Line height (default)
	:	:
	255	255 Line height
<b>MDBOX_HW</b>		Define the horizontal size of 2D arrayed box.
	0	0 Pixel width (default)
	:	:
	255	510 Pixels width
<b>MDBOX_BNDEN</b>		Enable the boundary of 2D arrayed box.
	0	Disable the boundary (default)
	1	Enable the boundary
<b>MD_BNDRY_COLR</b>		Define the color of 2D arrayed box boundary
	0	0 % Black (default)
	1	25% Gray
	2	50% Gray
	3	75% White
		Define the displayed color for cursor cell and motion-detected region
	0,1	75% White (default)
	2,3	0% Black
<b>MDCUR_HPOS</b>		Indicate the horizontal location of the cursor cell
<b>MDCUR_VPOS</b>		Indicate the vertical location of the cursor cell
<b>MDBOX_HCELL</b>		Indicate the number of columns in the 2D box
<b>MDBOX_VCELL</b>		Indicate the number of rows in the 2D box



**CURSOR CONTROL**

Address	[7]	[6]	[5]	[4]	[3]	[2]	[1]	[0]
0x65B								CUR_EN

**CUR\_EN** Enable the 5 OSD cursors. Only one of the 5 should be turned on.  
 Bit 0: Display VGA OSD  
 Bit 1: Display CVBS OSD  
 Bit 2: Record 0 OSD  
 Bit 3: Record 1 OSD  
 Bit 4: SPOT OSD

Address	[7]	[6]	[5]	[4]	[3]	[2]	[1]	[0]
0x65C	CUR_REV	CUR_BLINK	CUR_HOLLOW_OFF	CUR_CUSTOM_LD				CUR_SEL

**CUR\_REV** Reverse the cursor color (black become white, white become black)

**CUR\_BLINK** Enable blink of mouse pointer.  
 0 Disable cursor blinking (default)  
 1 Enable cursor blinking

**CUR\_HOLLOW\_OFF** Control interior pixel color of the cursor.  
 0 Hollow cursor shape (only the border pixels are shown) (default)  
 1 Filled with solid color specified by the cursor pixel

**CUR\_CUSTOM\_LD** Load the customized cursor shape from DDR memory into the on chip SRAM

**CUR\_SEL** Select the cursor type  
 0 Small cursor  
 1 Normal cursor  
 2 Customized cursor implemented with SRAM  
 3 Reserved

Address	[7]	[6]	[5]	[4]	[3]	[2]	[1]	[0]
0x65D			CUR_Y[10:8]				CUR_X[10:8]	
0x65E					CUR_X[7:0]			
0x65F					CUR_Y[7:0]			

**CUR\_X** Control the horizontal location of mouse pointer.  
 0 0 Pixel position (default)  
 : :  
 1440 1440 Pixel position

**CUR\_Y** Control the vertical location of mouse pointer.  
 0 0 Line position (default)  
 : :  
 900 900 Line position

## Audio CODEC

Address	[7]	[6]	[5]	[4]	[3]	[2]	[1]	[0]
0xEBA					AIGAIN1			
0xEBB	0	0	0	0	0	0	0	0
0xEBC	0	0	0	1	0	0	0	0
0xEBD	AIGAIN3				AIGAIN2			
0xEBE	AIGAIN5				AIGAIN4			

### AIGAIN

Select the amplifier's gain for each analog audio input AIN1 ~ AIN5.

0	0.25
1	0.31
2	0.38
3	0.44
4	0.50
5	0.63
6	0.75
7	0.88
8	1.00 (default)
9	1.25
10	1.50
11	1.75
12	2.00
13	2.25
14	2.50
15	2.75

Address	[7]	[6]	[5]	[4]	[3]	[2]	[1]	[0]
0x062	M_RLSWAP	RM_SYNC	RM_PBSEL		R_ADATM		R_MULTCH	

<b>M_RLSWAP</b>	<p>Define the sequence of mixing and playback audio data on the ADATM pin</p> <p>If RM_SYNC=0 : I2S format</p> <p>0     Mixing audio on position 0 and playback audio on position 8 (Default)</p> <p>1     Playback audio on position 0 and mixing audio on position 8</p> <p>If RM_SYNC=1 : DSP format</p> <p>0     Mixing audio on position 0 and playback audio on position 1 (Default)</p> <p>1     Playback audio on position 0 and mixing audio on position 1</p>
<b>RM_SYNC</b>	<p>Define the digital serial audio data format for record and mixing audio on the ACLKR, ASYNR, ADATR and ADATM pin</p> <p>0     I2S format (Default)</p> <p>1     DSP format</p>
<b>RM_PBSEL</b>	<p>Select the output PlayBackIn data for the ADATM pin</p> <p>0     First Stage PlayBackIn audio (Default)</p> <p>1     Second Stage PlayBackIn audio</p> <p>2     Third Stage PlayBackIn audio</p> <p>3     Last Stage PlayBackIn audio</p>
<b>R_ADATM</b>	<p>Select the output mode for the ADATM pin</p> <p>0     Digital serial data of mixing audio (Default)</p> <p>1     Digital serial data of ADATR format record audio</p> <p>2     Digital serial data of ADATM format record audio</p>
<b>R_MULTCH</b>	<p>Define the number of audio for record on the ADATR pin</p> <p>0     2 audios (Default)</p> <p>1     4 audios</p> <p>2     8 audios</p> <p>3     16 audios</p> <p>Number of output data are limited as shown on Sequence of Multi-channel Audio Record table. Also, each output position data are selected by R_SEQ_0/R_SEQ_1/.../R_SEQ_F registers.</p>

Address	[7]	[6]	[5]	[4]	[3]	[2]	[1]	[0]
0x063	AAUTO_MUTE	PBREFEN	VRSTSEL		FIRSTCNUM			

<b>AAUTO_MUTE</b>	<b>1</b>	When input Analog data is less than ADET_TH level, output PCM data will be set to 0. Audio DAC data input is 0x200.
	<b>0</b>	No effect
<b>PBREFEN</b>		Audio ACKG Reference (refin) input select
	<b>0</b>	ACKG has video VRST refin input selected by VRSTSEL register (Default)
	<b>1</b>	ACKG has audio ASYNP refin input
<b>VRSTSEL</b>		Select VRST(V reset) signal on ACKG (Audio Clock Generator) refin input .
	<b>0</b>	VIN0 Video Decoder Path VRST (default)
	<b>1</b>	VIN1 Video Decoder Path VRST
	<b>2</b>	VIN2 Video Decoder Path VRST
	<b>3</b>	VIN3 Video Decoder Path VRST
<b>FIRSTCNUM</b>		Set up First Stage number on audio cascade mode connection. Set up the value of (Cascade chip number-1). In 4 chips cascade case, this value is 3h for ALINK mode. In single chip application case, this doesn't need to be set up.
	<b>0</b>	(default)

Address	[7]	[6]	[5]	[4]	[3]	[2]	[1]	[0]
0x064	R_SEQ_1				R_SEQ_0			
0x065	R_SEQ_3				R_SEQ_2			
0x066	R_SEQ_5				R_SEQ_4			
0x067	R_SEQ_7				R_SEQ_6			
0x068	R_SEQ_9				R_SEQ_8			
0x069	R_SEQ_B				R_SEQ_A			
0x06A	R_SEQ_D				R_SEQ_C			
0x06B	R_SEQ_F				R_SEQ_E			

<b>R_SEQ</b>		Define the sequence of record audio on the ADATR pin. Refer to Table 15 for the detail of the R_SEQ_0 ~ R_SEQ_F. The default value of R_SEQ_0 is "0", R_SEQ_1 is "1", ... and R_SEQ_F is "F".
	<b>0</b>	AIN1
	<b>1</b>	AIN2
	<b>:</b>	<b>:</b>
	<b>:</b>	<b>:</b>
	<b>14</b>	AIN15
	<b>15</b>	AIN16

Address	[7]	[6]	[5]	[4]	[3]	[2]	[1]	[0]
0x06C	ADACEN	AADCEN	PB_MASTER	PB_LRSEL	PB_SYNC	RM_8BIT	ASYNROEN	ACLKRMAS

<b>ADACEN</b>	<b>Audio DAC Function mode</b> 0 Audio DAC function disable (test purpose only) 1 Audio DAC function enable (Default)
<b>AADCEN</b>	<b>Audio ADC Function mode</b> 0 Audio ADC function disable(test purpose only) 1 Audio ADC function enable (Default)
<b>PB_MASTER</b>	<b>Define the operation mode of the ACLKP and ASYNP pin for playback.</b> 0 All type I2S/DSP Slave mode (ACLKP and ASYNP is input) (Default) 1 TW2851 type I2S/DSP Master mode (ACLKP and ASYNP is output)
<b>PB_LRSEL</b>	<b>Select the channel for playback.</b> 0 Left channel audio is used for playback input (Default) 1 Right channel audio is used for playback input
<b>PB_SYNC</b>	<b>Define the digital serial audio data format for playback audio on the ACLKP, ASYNP and ADATP pin.</b> 0 I2S format (Default) 1 DSP format
<b>RM_8BIT</b>	<b>Define output data format per one word unit on ADATR pin.</b> 0 16bit one word unit output (Default) 1 8bit one word unit packed output
<b>ASYNROEN</b>	<b>Define input/output mode on the ASYNR pin.</b> 1 ASYNR pin is input 0 ASYNR pin is output (Default)
<b>ACLKRMAS</b>	<b>Define input/output mode on the ACLKR pin and set up audio 256xfs system processing</b> 0 ACLKR pin is input. External 256xfs clock should be connected to ACLKR pin. This function is single chip Audio slave mode only. 1 ACLKR pin is output. Internal ACKG generates 256xfs clock (Default)

Address	[7]	[6]	[5]	[4]	[3]	[2]	[1]	[0]
0x06D	LAWMD		MIX_DERATIO	MIX_MUTE				

**LAWMD** Select u-Law/A-Law/PCM/SB data output format on ADATR and ADATM pin.

- 0 PCM output (default)
- 1 SB(Signed MSB bit in PCM data is inverted) output
- 2 u-Law output
- 3 A-Law output

**MIX\_DERATIO** Disable the mixing ratio value for all audio.

- 0 Apply individual mixing ratio value for each audio (default)
- 1 Apply nominal value for all audio commonly

**MIX\_MUTE[n]** Enable the mute function for audio channel AINn when n is 0 to 3. It effects only for mixing. When n = 4, it enable the mute function of the playback audio input. It effects only for single chip or the last stage chip

- 0 Normal
- 1 Muted (default)

Address	[7]	[6]	[5]	[4]	[3]	[2]	[1]	[0]
0x0E0	MRATIOMD	0	0	0	0	0	0	0
0x06E	MIX_RATIO2				MIX_RATIO1			
0x06F	MIX_RATIO4				MIX_RATIO3			
0x070	0	0	0	0	MIX_RATIOOP			

**MIX\_RATIO<sub>n</sub>** Define the ratio values for audio mixing of channel AINn  
**MIX\_RATIO<sub>OP</sub>** Define the ratio values for audio mixing of playback audio input  
 If MRATIOMD = 0 (default)

- 0 0.25
- 1 0.31
- 2 0.38
- 3 0.44
- 4 0.50
- 5 0.63
- 6 0.75
- 7 0.88
- 8 1.00 (default)
- 9 1.25
- 10 1.50
- 11 1.75
- 12 2.00
- 13 2.25
- 14 2.50
- 15 2.75

If MRATIONMD = 1, Mixing ratio is MIX\_RATIO<sub>n</sub> / 64

Address	[7]	[6]	[5]	[4]	[3]	[2]	[1]	[0]
0x071	V_ADC_CKPOL	A_ADC_CKPOL	A_DAC_CKPOL	MIX_OUTSEL				

V\_ADC\_CKPOL Test purpose only (Default 0)

A\_ADC\_CKPOL Test purpose only (Default 0)

A\_DAC\_CKPOL Test purpose only (Default 0)

MIX\_OUTSEL Define the final audio output for analog and digital mixing out.

- 0 Select record audio of channel 1
- 1 Select record audio of channel 2
- 2 Select record audio of channel 3
- 3 Select record audio of channel 4
- 4 Select record audio of channel 5
- 5 Select record audio of channel 6
- 6 Select record audio of channel 7
- 7 Select record audio of channel 8
- 8 Select record audio of channel 9
- 9 Select record audio of channel 10
- 10 Select record audio of channel 11
- 11 Select record audio of channel 12
- 12 Select record audio of channel 13
- 13 Select record audio of channel 14
- 14 Select record audio of channel 15
- 15 Select record audio of channel 16
- 16 Select playback audio of the first stage chip
- 17 Select playback audio of the second stage chip
- 18 Select playback audio of the third stage chip
- 19 Select playback audio of the last stage chip
- 20 Select mixed audio (default)
- 21 Select record audio of channel AIN51
- 22 Select record audio of channel AIN52
- 23 Select record audio of channel AIN53
- 24 Select record audio of channel AIN54

Address	[7]	[6]	[5]	[4]	[3]	[2]	[1]	[0]
0x072	AAMPMD	ADET_FILT			ADET_TH4[4]	ADET_TH3[4]	ADET_TH2[4]	ADET_TH1[4]
0x073	ADET_TH2[3:0]			ADET_TH1[3:0]				
0x074	ADET_TH4[3:0]			ADET_TH3[3:0]				

<b>AAMPMD</b>	Define the audio detection method. 0 Detect audio if absolute amplitude is greater than threshold 1 Detect audio if differential amplitude is greater than Threshold (default)
<b>ADET_FILT</b>	Select the filter for audio detection (default 4h) 0 Wide LPF : : 7 Narrow LPF
<b>ADET_THn</b>	Define the threshold value for audio detection of AINn (Default Ah) 0 Low value : : 31 High value

If fs = 8kHz Audio Clock setting mode, Registers

0x072 = 0xC0  
0x073 = 0xAA  
0x074 = 0xAA

are typical setting.

If fs=16kHz/32kHz/44.1kHz/48kHz Audio Clock setting mode, Registers

0x072 = 0xE0  
0x073 = 0xBB  
0x074 = 0xBB

are typical setting.

Address	[7]	[6]	[5]	[4]	[3]	[2]	[1]	[0]
0x075	ACKI[7:0]							
0x076	ACKI[15:8]							
0x077	0	0	ACKI[21:16]					

<b>ACKI</b>	These bits control ACKI Clock Increment in ACKG block. 09B583h for fs = 8kHz is default
-------------	--

Address	[7]	[6]	[5]	[4]	[3]	[2]	[1]	[0]
0x078	ACKN[7:0]							
0x079	ACKN[15:8]							
0x07A	0	0	0	0	0	0	ACKN[17:16]	

<b>ACKN</b>	These bits control ACKN Clock Number in ACKG block.. 000100h for Playback Slave-in lock is default.
-------------	--



Address	[7]	[6]	[5]	[4]	[3]	[2]	[1]	[0]
0x07B	0	0	SDIV					

**SDIV** These bits control SDIV Serial Clock Divider in ACKG block (Default 01h)

Address	[7]	[6]	[5]	[4]	[3]	[2]	[1]	[0]
0x07C	0	0	LRDIV					

**LRDIV** These bits control LRDIV Left/Right Clock Divider in ACKG block (Default 20h)

Address	[7]	[6]	[5]	[4]	[3]	[2]	[1]	[0]
0x07D	APZ	APG			0	ACPL	SRPH	LRPH

**APZ** These bits control Loop in ACKG block (Default 1)

**APG** These bits control Loop in ACKG block (Default 4h)

**ACPL** These bits control Loop closed/open in ACKG block  
 0 Loop closed  
 1 Loop open (recommended on typical application case)  
 (Default)

**SRPH** Reserved. These bits are not used in TW2851 chip.

**LRPH** Reserved. These bits are not used in TW2851 chip.

Address	[7]	[6]	[5]	[4]	[3]	[2]	[1]	[0]
0x0D0	AADC4OFS[9:8]		AADC3OFS[9:8]		AADC2OFS[9:8]		AADC1OFS[9:8]	
0x0D1	AADC1OFS[7:0]							
0x0D2	AADC2OFS[7:0]							
0x0D3	AADC3OFS[7:0]							
0x0D4	AADC4OFS[7:0]							
0x0D5	0	0	0	0	0	0	AADC5OFS[9:8]	
0x0D6	AADC5OFS[7:0]							

Digital ADC input data offset control. Digital ADC input data is adjusted by

$$ADJAADCn = AUDADCn + AADCnOFS$$

Where AUDADCn is 2's formatted Analog Audio ADC output, and AADCnOFS is adjusted offset value by 2's format. All default 10bit data value is 3EFh.

Address	[7]	[6]	[5]	[4]	[3]	[2]	[1]	[0]
0x0D7	0	ADCISEL			AUDADCn[9:8]*		ADJAADCn[9:8]*	
0x0D8	AUDADCn[7:0]*							
0x0D9	ADJAADCn[7:0]*							

<b>AUDADCn</b>	Current Analog Audio n ADC Digital Output Value by 2's format These value show the first input data value in front of Digital Audio Decimation Filtering process.										
<b>ADJAADCn</b>	Current adjusted Audio ADC Digital input data value by 2's format. These value show the first input data value in front of Digital Audio Decimation Filtering process.										
<b>ADCISEL</b>	Select AUDADCn, ADJAADCn Audio input number. AUDADCn and ADJAADCn read value shows following selected Audio input data. <table> <tbody> <tr> <td>0</td> <td>AIN1</td> </tr> <tr> <td>1</td> <td>AIN2</td> </tr> <tr> <td>2</td> <td>AIN3</td> </tr> <tr> <td>3</td> <td>AIN4</td> </tr> <tr> <td>4</td> <td>AIN5</td> </tr> </tbody> </table>	0	AIN1	1	AIN2	2	AIN3	3	AIN4	4	AIN5
0	AIN1										
1	AIN2										
2	AIN3										
3	AIN4										
4	AIN5										

Address	[7]	[6]	[5]	[4]	[3]	[2]	[1]	[0]
0x0DA	0	0	0	I2SO_RSEL				
0x0DB	0	0	0	I2SO_LSEL				
0x0DC	I2SRECSEL53		I2SRECSEL52		I2SRECSEL51		I2SRECSEL50	
0x0DD	A5OUT_OFF	ADATM_I2SOEN	MIX_MUTE_A5	ADET_TH5				

<b>A5OUT_OFF</b>	AIN5 data output control on ADATR record signal. 0 Output AIN51/AIN52/AIN53/AIN54 record data on ADATR 1 Not output AIN51/AIN52/AIN53/AIN54 record data on ADATR
<b>ADATM_I2SOEN</b>	Define ADATM pin output 2 word data to make standard I2S output. 0 Output Mixing or Playback data only on ADATM pin as specified by M_RLSWAP register (Default) 1 L/R data on ADATM pin is selected by I2SO_RSEL/I2SO_LSEL registers
<b>MIX_MUTE_A5</b>	Audio input AIN5 mute function control 0 Normal 1 Muted
<b>ADET_TH5</b>	AIN5 threshold value for audio detection
<b>I2SO_RSEL/ I2SO_LSEL</b>	Select L/R output data on ADATM pin when ADATM_I2SOEN=1. Both I2SO_RSEL and I2SO_LSEL select output data by following order. 0 Select record audio of channel 1(AIN0) 1 Select record audio of channel 2(AIN1) 2 Select record audio of channel 3(AIN2) 3 Select record audio of channel 4(AIN3) 4 Select record audio of channel 5(AIN4) 5 Select record audio of channel 6(AIN5) 6 Select record audio of channel 7(AIN6) 7 Select record audio of channel 8(AIN7) 8 Select record audio of channel 9(AIN8) 9 Select record audio of channel 10(AIN9) 10(Ah) Select record audio of channel 11(AIN10) 11(Bh) Select record audio of channel 12(AIN11) 12(Ch) Select record audio of channel 13(AIN12) 13(Dh) Select record audio of channel 14(AIN13) 14(Eh) Select record audio of channel 15(AIN14) 15(Fh) Select record audio of channel 16(AIN15) 16(10h) Select playback audio of the first stage chip (PB1) 17(11h) Select playback audio of the second stage chip (PB2) 18(12h) Select playback audio of the third stage chip (PB3) 19(13h) Select playback audio of the last stage chip (PB4) 20(14h) Select mixed audio 21(15h) Select record audio of channel 51(AIN51) (default) 22(16h) Select record audio of channel 52(AIN52) 23(17h) Select record audio of channel 53(AIN53) 24(18h) Select record audio of channel 54(AIN54) Others No audio output
<b>I2SRECSEL5n</b>	Select output data of port n in the position below

0	AIN51
1	AIN52
2	AIN53
3	AIN54

Address	[7]	[6]	[5]	[4]	[3]	[2]	[1]	[0]
0x0DE					MIX_RATIO5			

**MIX\_RATIO5**

Define the ratio values for audio mixing of channel AIN4 using MIX\_RATIO4 to the ratio values for audio mixing of playback audio input

If MRATIO5MD = 0 (default)

0	0.25
1	0.31
2	0.38
3	0.44
4	0.50
5	0.63
6	0.75
7	0.88
8	1.00 (default)
9	1.25
10	1.50
11	1.75
12	2.00
13	2.25
14	2.50
15	2.75

If MRATIO5MD = 1, Mixing ratio is MIX\_RATIO4 / 64

Address	[7]	[6]	[5]	[4]	[3]	[2]	[1]	[0]
0x0DF	ATHROUGH H	ASYNSERI AL	ACLKR128	ACLKR64	AFS384	AIN5MD	0	0

ATHROUGH	Default 0
ASYNSERIAL	Default 0
ACLKR128	ACLKR clock output mode for special 16x8bit (total 128bit) data interface. 0 ACLKR output is normal (Default). 1 the number of ACLKR clock per fs is 128.This function is effective with RM_8BIT=1 8bit mode (special purpose).
ACLKR64	ACLKR clock output mode for special 4 word output interface. ACLKRMAS <sup>T</sup> ER=1 mode only. 0 ACLKR output is normal (Default) 1 the number of ACLKR clock per fs is 64.
AFS384	Special Audio fs Sampling mode. 0 Audio fs Sampling mode is normal 256xf <sup>s</sup> if AIN5 = 0. (Default) 1 Audio fs Sampling mode is 384xf <sup>s</sup> mode. In this mode, A1MANU=1, A1NUM=0, A2NUM=1, A3NUM=2, A4NUM = 3, A5NUM=4 setting are needed.
AIN5MD	Audio Input process mode 0 AIN1/AIN2/AIN3/AIN4 4 audio input mode. This mode is 256xf <sup>s</sup> if AFS384 = 0. In this mode, AIN5 is not used. 1 AIN1/AIN2/AIN3/AIN4/AIN5 5 audio input mode. This mode is 320xf <sup>s</sup> mode if AFS384 = 0.

Address	[7]	[6]	[5]	[4]	[3]	[2]	[1]	[0]
0x0E0	MRATIOMD	ADACTEST	0	0	0	0	0	0

MRATIOMD	1 Use a more exponential way to interpret the MRATIO. Perform the following transformation before using the ratio 0 ~ 3 => 4 ~ 7 4 ~ 7 => 8 ~ 14 8 ~ 11 => 16 ~ 28 12 ~ 15 => 32 ~ 44 0 Use the MRATIO as the ratio
ADACTEST	Test feature for ADAC. Set to 0.

Address	[7]	[6]	[5]	[4]	[3]	[2]	[1]	[0]
0x0E3	0	0	ACLKRPOL	ACLKPPOL	AFAUTO	AFMD		

ACLKRPOL	ACLKR input signal polarity inverse. 0 Not inverted (Default) 1 Inversed
ACLKPPOL	ACLKP input signal polarity inverse.

	0	Not inverted (Default)
	1	Inversed
<b>AFAUTO</b>	<b>ACKI[21:0] control automatic set up with AFMD registers</b> This mode is only effective when <b>ACLKRMAS</b> TER=1	
	0	ACKI[21:0] registers set up ACKI control
	1	ACKI control is automatically set up by AFMD register values
<b>AFMD</b>	<b>AFAUTO control mode</b>	
	0	8kHz setting (Default)
	1	16kHz setting
	2	32kHz setting
	3	44.1kHz setting
	4	48kHz setting

Address	[7]	[6]	[5]	[4]	[3]	[2]	[1]	[0]
0x0E4	I2S8MODE	MASCKMD	PBINSWAP	ASYNRDLY	ASYNPDLY	ADATPDLY	INLAWMD	

<b>I2S8MODE</b>	<b>8bit I2S Record output mode.</b>	
	0	L/R half length separated output (Default).
	1	One continuous packed output equal to DSP output format.
<b>MASCKMD</b>	<b>Audio Clock Master ACLKR output wave format.</b>	
	0	High period is one 27MHz clock period (default).
	1	Almost duty 50-50% clock output on ACLKR pin. If this mode is selected, two times bigger number value need to be set up on the ACKI register. If AFAUTO=1, ACKI control is automatically set up even if MASCKMD=1.
<b>PBINSWAP</b>	<b>Playback ACLKP/ASYNP/ADATP input data MSB-LSB swapping.</b>	
	0	Not swapping
	1	Swapping.
<b>ASYNRDLY</b>	<b>ASYNR input signal delay.</b>	
	0	No delay
	1	Add one 27MHz period delay in ASYNR signal input
<b>ASYNPDLY</b>	<b>ASYNP input signal delay.</b>	
	0	no delay
	1	add one 27MHz period delay in ASYNP signal input
<b>ADATPDLY</b>	<b>ADATP input data delay by one ACLKP clock.</b>	
	0	No delay (Default).This is for I2S type 1T delay input interface.
	1	Add 1 ACLKP clock delay in ADATP input data. This is for left-justified type 0T delay input interface.
<b>INLAWMD</b>	<b>Select u-Law/A-Law/PCM/SB data input format on ADATP pin.</b>	
	0	PCM input (Default)
	1	SB (Signed MSB bit in PCM data is inverted) input
	2	u-Law input
	3	A-Law input

Address	[7]	[6]	[5]	[4]	[3]	[2]	[1]	[0]
0x0E5	0	0	0	0	0	0	AINTPOFF	A5DETENA

AINTPOFF Test feature for ADAC. Set to 0.

A5DETENA Enable state register updating and interrupt request of audio AIN5 detection for each input  
 0 Disable state register updating and interrupt request  
 1 Enable state register updating and interrupt request

## Host Interface

### VGA DDC INTERFACE CONTROL

Address	[7]	[6]	[5]	[4]	[3]	[2]	[1]	[0]
0x9C0	DDC_FREQ_DIV[7:0]							
0x9C1	DDC_FREQ_DIV[15:8]							

DDC\_FREQ\_DIV DDC I2C Clock Generator generates DDC\_CLK from an internal 54 MHz clock divided by DDC\_FREQ\_DIV.

Address	[7]	[6]	[5]	[4]	[3]	[2]	[1]	[0]
0x9C2	DDC_WR_DATA							

DDC\_WR\_DATA DDC I2C Write Data Register

At the start operation, the content is as follows  
 Slave\_Device\_Addr DDC\_WR\_DATA[7:1]  
 R/W Command DDC\_WR\_DATA[0]  
 1 Read  
 0 Write

Address	[7]	[6]	[5]	[4]	[3]	[2]	[1]	[0]
0x9C3	DDC_RD_DATA							

DDC\_RD\_DATA DDC I2C Read Data Register

Address	[7]	[6]	[5]	[4]	[3]	[2]	[1]	[0]
0x9C4	DDC_COMMAND							

DDC\_COMMAND

DDC Control Command (Read/Write)

- 7 I2C Start
- 6 I2C Stop
- 5 Read the value from the slave device register. Once acknowledged, the data will be in DDC\_RD\_DATA Register
- 4 Write the value in DDC\_WR\_DATA onto DDC\_DATA bus
- 3 Send an ACK to the DDC\_DATA bus when read
- 2 Clock Count Enable
- 1 Interrupt Enable
- 0 Interrupt Acknowledge

Address	[7]	[6]	[5]	[4]	[3]	[2]	[1]	[0]
0x9C5	DDC_STATUS							

DDC\_STATUS

DDC Status Register (read only)

- Bit 7 RXACK
- Bit 6 I2C\_BUSY
- Bit 5 Active Low
- Bit 4 0
- Bit 3 0
- Bit 2 0
- Bit 1 I2C Read/Write
- Bit 0 Interrupt Acknowledge

Address	[7]	[6]	[5]	[4]	[3]	[2]	[1]	[0]
0x9C7	0							

Reserved

Should be kept 0

Address	[7]	[6]	[5]	[4]	[3]	[2]	[1]	[0]
0x9CF	DDC_RST							

DDC\_RST

DDC Software Reset whenever CPU issues a write to this address



## PS2 MOUSE INTERFACE CONTROL

Address	[7]	[6]	[5]	[4]	[3]	[2]	[1]	[0]
0x9D0	PS2_MaxNoSig			PS2_MaxByte		PS2_WR_EN	PS2_EN	

**PS2\_MaxNoSig** Specify the length of time used to flag no signal when PS2\_CK is not toggled.

**PS2\_MaxByte** Maximum number of bytes used in PS2 read operation from PS2\_D

**PS2\_WR\_EN** PS2 Data Write Enable to write data in PS2\_WR\_DATA onto PS2\_D

**PS2\_EN** PS2 Enable

Address	[7]	[6]	[5]	[4]	[3]	[2]	[1]	[0]
0x9D1	PS2_WR_DATA							

**PS2\_WR\_DATA** Before writing this register, make sure the 0x9D0 control is written with PS2\_WR\_EN = 1 and PS2\_EN = 1.

Once writing into this register, the PS2 interface start sending PS2\_WR\_DATA onto PS2\_D bus.

Address	[7]	[6]	[5]	[4]	[3]	[2]	[1]	[0]
0x9D2	PS2_RD_DATA[7:0]							
0x9D3	PS2_RD_DATA[15:8]							
0x9D4	PS2_RD_DATA[23:16]							
0x9D5	PS2_RD_DATA[31:24]							

**PS2\_RD\_DATA** Data read back from PS2 port. If PS2\_WR\_EN = 0, and PS2\_EN = 1, and the PS2 Interrupt is asserted, the data on PS2\_D bus are available in these registers. The maximum number of valid bytes is determined by PS2\_MaxByte in 0x9D0

Address	[7]	[6]	[5]	[4]	[3]	[2]	[1]	[0]
0x9DF	PS2_RST							

**PS2\_RST** PS2 Software Reset whenever CPU issues a write to this address

## INTERRUPT

Address	[7]	[6]	[5]	[4]	[3]	[2]	[1]	[0]
0x1D0	INTERRUPT_VECT0							
0x1D1	INTERRUPT_VECT1							
0x1D2	INTERRUPT_VECT2							
0x1D3	INTERRUPT_VECT3							
0x1D4	INTERRUPT_VECT4							
0x1D5	INTERRUPT_VECT5							
0x1D6	INTERRUPT_VECT6							
0x1D7	INTERRUPT_VECT7							
0x1D8	INTERRUPT_VECT_MASK0							
0x1D9	INTERRUPT_VECT_MASK1							
0x1DA	INTERRUPT_VECT_MASK2							
0x1DB	INTERRUPT_VECT_MASK3							
0x1DC	INTERRUPT_VECT_MASK4							
0x1DD	INTERRUPT_VECT_MASK5							
0x1DE	INTERRUPT_VECT_MASK6							
0x1DF	INTERRUPT_VECT_MASK7							
0x1E0	INTERRUPT_STATUS							

**INTERRUPT\_VECTn**      Read      Read the interrupt status of the specific interrupt source  
 Write      Write a '1' to that bit will clear the specific interrupt source. This clear bit will make the INTERRUPT\_VECT to become '0'

**INTERRUPT\_VECT\_MASKn**  
 1      Set to '1' will allow the INTERRUPT\_VECT source to show up at the output IRQ pin if the vector bit is a '1'  
 0      Set to '0' will disable the output to IRQ, so the MCU will ignore that source

**INTERRUPT\_STATUS[x]**  
 1      An INTERRUPT\_STATUS[x] of '1' means there is some source in INTERRUPT\_VECTx set to 1. The MCU can read this register before it read each of the INTERRUPT\_VECTx.

The specific interrupt vector is organized as follows:

INTERRUPT_VECT0[3:0]	Video Decoder Motion Detection, ANA_SW = 0
INTERRUPT_VECT0[7:4]	Video Decoder Motion Detection, ANA_SW = 1
INTERRUPT_VECT1[3:0]	Video Decoder Night Detection, ANA_SW = 0
INTERRUPT_VECT1[7:4]	Video Decoder Night Detection, ANA_SW = 1
INTERRUPT_VECT2[3:0]	Video Decoder Black Detection, ANA_SW = 0
INTERRUPT_VECT2[7:4]	Video Decoder Black Detection, ANA_SW = 1
INTERRUPT_VECT3[3:0]	Video Decoder NO VIDEO detection, ANA_SW = 0
INTERRUPT_VECT3[7:4]	Video Decoder NO VIDEO detection, ANA_SW = 1
INTERRUPT_VECT4[3:0]	Unused

INTERRUPT_VECT4[7:4]	Playback port CHID Detection
INTERRUPT_VECT5[3:0]	Playback port NO VIDEO Detection
INTERRUPT_VECT5[7:4]	Playback muxed channel PORT Change Detection
INTERRUPT_VECT6[0]	Display Strobe Done
INTERRUPT_VECT6[1]	Record Strobe Done
INTERRUPT_VECT6[2]	SPOT Strobe Done
INTERRUPT_VECT6[3]	Record Read/Write Switch Queue Done
INTERRUPT_VECT6[4]	SPOT Read/Write Switch Queue Done
INTERRUPT_VECT6[5]	PS2 Mouse Interrupt
INTERRUPT_VECT6[6]	OSG Bitmap Done (or Wait)
INTERRUPT_VECT6[7]	DDC Channel Interrupt
INTERRUPT_VECT7[0]	Display VGA Vstart
INTERRUPT_VECT7[1]	Display CVBS Vstart
INTERRUPT_VECT7[2]	Record Vstart
INTERRUPT_VECT7[3]	SPOT Vstart
INTERRUPT_VECT7[4]	Unused
INTERRUPT_VECT7[5]	Unused
INTERRUPT_VECT7[6]	Unused
INTERRUPT_VECT7[7]	Unused

## DDR BURST

Address	[7]	[6]	[5]	[4]	[3]	[2]	[1]	[0]
0x2DF	AUX_DDR_DATA							

**AUX\_DDR\_DATA** The data register used to read/write the internal 64 bytes FIFO used to burst to/from the DDR

Address	[7]	[6]	[5]	[4]	[3]	[2]	[1]	[0]
0x2E0	AUX_DDR_ADDR[7:0]							
0x2E1	AUX_DDR_ADDR[15:8]							
0x2E2	AUX_DDR_ADDR[23:16]							

**AUX\_DDR\_ADDR** The address registers used to burst read/write to/from DDR

Address	[7]	[6]	[5]	[4]	[3]	[2]	[1]	[0]	
0x2E3	AUX_DDR_LENGTH[7:0]								
0x2E4	AUX_WAIT_POL	AUX_DDR_LENGTH[10:8]			AUX_FIFO_EMPTY*	AUX_FIFO_FULL*	AUX_DDR_RD	AUX_DDR_WR	

<b>AUX_DDR_LENGTH</b>	Specify the length of the CPU burst read/write to/from DDR. The Maximum length is 1204 bytes
<b>AUX_WAIT_POL</b>	Reverse the polarity of the AUX WAIT signal
<b>AUX_FIFO_EMPTY</b>	The internal 64 bytes FIFO emptiness status flag <b>1</b> The 64 bytes internal FIFO is empty and available for writing data to burst to DDR <b>0</b> The 64 bytes internal FIFO is not empty, meaning the previous move from FIFO to DDR is not completed yet. The CPU should wait until this bit is set before writing a new 64 bytes.
<b>AUX_FIFO_FULL</b>	The internal 64 bytes FIFO has data available for CPU to read This bit allows the CPU to poll after an AUX_DDR_RD command is issued, or after every 64 bytes of data are read. With this bit set, the CPU is safe to read up to 64 bytes, or up to the last burst length derived from the AUX_DDR_LENGTH <b>1</b> The 64 bytes internal FIFO has some data Available for CPU to read <b>0</b> The 64 bytes internal FIFO does not have data for CPU to read yet
<b>AUX_DDR_WR</b>	The AUX DDR Write Command. This bit is self-cleared
<b>AUX_DDR_RD</b>	The AUX DDR Read Command. This bit is self-cleared.

## DDR Memory Controller

Address	[7]	[6]	[5]	[4]	[3]	[2]	[1]	[0]
0x2E5		DDR_RD_CLK_SEL			DDR_DQS_RD_DLY		DDR_RD_TO_WR_NOP	

<b>DDR_RD_CLK_SEL</b>	Select the DQS or ~DQS as read clock to latch the DQ
<b>DDR_DQS_RD_DLY</b>	Select the DQS valid read data cycle delay number
<b>DDR_RD_TO_WR_NOP</b>	DDR read to write adds additional nop cycles. Default 0

Address	[7]	[6]	[5]	[4]	[3]	[2]	[1]	[0]
0x2E6								DDR_DQS_SELO
0x2E7								DDR_DQS_SEL1
0x2E8		OSG_DDR_TIMER						DDR_CLK90_SEL

**DDR\_DQS\_SELO** Select DDR\_DQS\_SEL/32 clock phase delay

**DDR\_DQS\_SEL1** Select DDR\_DQS\_SEL/32 clock phase delay

**DDR\_CLK90\_SEL** Select the phase of 90 degree CLK generated from DLL.  
The phase is DDR\_CLK90\_SEL/32

**OSG\_DDR\_TIMER** Timer to slow down the OSG write to avoid excessive peak bandwidth

Address	[7]	[6]	[5]	[4]	[3]	[2]	[1]	[0]
0x2E9	DDR_DLL_TEST_SEL		DDR_DLL_DEBUG_SEL					DDR_DLL_TAP_S

**DDR\_DLL\_DEBUG\_SEL** Debug select to the DLL Debug Output

**DDR\_DLL\_TEST\_SEL** Select the DLL test output signal

**DDR\_DLL\_TAP\_S** Select the DLL TAPS

Address	[7]	[6]	[5]	[4]	[3]	[2]	[1]	[0]
0x2EA	DDR_T_RC				DDR_T_RAS			
0x2EB	DDR_T_RFC						DDR_T_RP	
0x2EC		DDR_T_RCD					DDR_T_WR	

**DDR\_T\_RC** DDR t<sub>rc</sub> timing

**DDR\_T\_RAS** DDR t<sub>ras</sub> timing

**DDR\_T\_RFC** DDR t<sub>rfc</sub> timing

**DDR\_T\_RP** DDR t<sub>rp</sub> timing

**DDR\_T\_RCD** DDR t<sub>rcd</sub> timing

**DDR\_T\_WR** DDR t<sub>wr</sub> timing

Address	[7]	[6]	[5]	[4]	[3]	[2]	[1]	[0]
0x2ED		DDR_REFRESH			DDR_INIT_BYPASS	DDR_B_LENGTH		

**DDR\_REFRESH** DDR refresh timing control

**DDR\_INIT\_BYPASS** DDR initialization bypass (for simulation purpose only)

**DDR\_B\_LENGTH** DDR burst length

Address	[7]	[6]	[5]	[4]	[3]	[2]	[1]	[0]
---------	-----	-----	-----	-----	-----	-----	-----	-----

0x2EE		DDR_CAS_LAT	DDR_SAMSUNG	0	DDR_SIZE
-------	--	-------------	-------------	---	----------

DDR\_CAS\_LAT            DDR CAS Latency

DDR\_SAMSUNG           Internal test mode

DDR\_SIZE

Address	[7]	[6]	[5]	[4]	[3]	[2]	[1]	[0]
0x2EF	DDR_WTR	DDR_B_TYPE	DDR_DV_ST	DDR_EN_DLL				

DDR\_WTR                1     DDR Write to Read Turn Around cycle needed  
                               0     No Write to Read Turn Around cycle needed

DDR\_B\_TYPE            External DDR Burst Type, for initialization use

DDR\_DV\_ST             Configure external DDR driving strength, for initialization use

DDR\_EN\_DLL            Enable the DLL in the external DDR memory, for initialization use

## Misc Control

Address	[7]	[6]	[5]	[4]	[3]	[2]	[1]	[0]
0x2F0	SOFT_RSTN	DLL_RST						

SOFT\_RSTN            Software resetn signal for the whole chip. This bit does not reset the configuration registers.

0     Reset  
 1     Release Reset

DLL\_RST                1     Reset DLLs  
                               0     Release Reset DLLs

Address	[7]	[6]	[5]	[4]	[3]	[2]	[1]	[0]
0x2F1								CHIP_ID

CHIP\_ID                Set the chip ID in cascade mode.

Address	[7]	[6]	[5]	[4]	[3]	[2]	[1]	[0]
0x2F5	SP_CC_CLK_SEL		RP_CC_CLK_SEL		0	0	0	0

SP\_CC\_CLK\_SEL        [1]    Reverse the SPOT output sampling across clock domain from SCLK to CLKOS  
                               [0]    Reverse the SPOT input sampling across clock domain from CLKIS to SCLK

RP\_CC\_CLK\_SEL        [1]    Reverse the RECORD output sampling across clock domain from RCLK to CLKOY  
                               [0]    Reverse the RECORD input sampling across clock domain from CLKIY to RCLK

Address	[7]	[6]	[5]	[4]	[3]	[2]	[1]	[0]
0x2F8	DP_CLK_CSCD_SEL		DP_CLK_CSCD_PD	CLKOX_SEL				

- DP\_CLK\_CSCD\_SEL**      Select the clock source of the internal Display Cascade module clock  
 0      54 MHz  
 1      27 MHz  
 2      108 MHz  
 3      PPLL clock output
- DP\_CLK\_CSCD\_PD**      Power down the display cascade clock
- CLKOX\_SEL**            Select the source of the display output CLKOX pin  
 0      From cascade clock as determined by DP\_CLK\_CSCD\_SEL  
 1      From 27 MHz Clock Source

Address	[7]	[6]	[5]	[4]	[3]	[2]	[1]	[0]
0x2FB	CLKOY1_POL	CLKOY0_POL	CLKOS_POL	CLKOX_POL				

- CLKOY1\_POL**            Reverse the clock polarity of output CLKOY1 pin
- CLKOY0\_POL**            Reverse the clock polarity of output CLKOY0 pin
- CLKOS\_POL**             Reverse the clock polarity of the CLKOS pin
- CLKOX\_POL**             Reverse the clock polarity of the CLKOX pin

Address	[7]	[6]	[5]	[4]	[3]	[2]	[1]	[0]
0x2FC				CLKIX_POL				CLKPB_POL

- CLKIX\_POL**             Reverse the CLKIX polarity
- CLKPB\_POL**             Reverse the CLKPB polarity

Address	[7]	[6]	[5]	[4]	[3]	[2]	[1]	[0]
0x2FD	CLKOS_DLY				CLKOX_DLY			

- CLKOS\_DLY**             Select the delay of CLKOS
- CLKOX\_DLY**             Select the delay of CLKOX

Address	[7]	[6]	[5]	[4]	[3]	[2]	[1]	[0]
0x2FE	CLKOY1_DLY				CLKOY0_DLY			

- CLKOY1\_DLY**            Select the delay of CLKOY1
- CLKOY0\_DLY**            Select the delay of CLKOY0

Address	[7]	[6]	[5]	[4]	[3]	[2]	[1]	[0]
0xE00							0	0

Reserved

Address	[7]	[6]	[5]	[4]	[3]	[2]	[1]	[0]
0xEB0	PPLL_F[7:0]							
0xEB1	PPLL_OD			PPLL_R				
0xEB2	EXT_PCLK_SEL					PPLL_OE	PPLL_BP	

PPLL is controlled with the following equation

$$F_{OUT} = (F_{IN} * 2 * F) / (R * N_{O})$$

With the following restriction:

$$2 \text{ MHz} < F_{IN} / R < 8 \text{ MHz}$$

$$200 \text{ MHz} < F_{OUT} * N_{O} < 400 \text{ MHz}$$

$$50 \text{ MHz} < F_{OUT} < 400 \text{ MHz}$$

PPLL_F	The F parameter in the equation
PPLL_R	The R parameter in the equation
PPLL_OD	OD of PLL, determines the NO in the equation
0	NOT ALLOWED
1	NO = 1
2	NO = 2
3	NO = 4
EXT_PCLK_SEL	Select the external PCLK, rather than using the internal PLL Clock
	3'b1xx Force pclk to 0
	3'b000 Select PPLL_CLK
	3'b010 Select PPLL_CLK/2
	3'b0x1 Select P_EXT_PCLK
PPLL_OE	OE of PCLK PLL
PPLL_BP	Bypass of PCLK PLL



Address	[7]	[6]	[5]	[4]	[3]	[2]	[1]	[0]
0xEB4	MPLL_F[7:0]							
0xEB5	MPLL_OD			MPLL_R				
0xEB6						EXT_MCLK_SEL	MPLL_OE	MPLL_BP

MPLL is controlled with the following equation

$$FOUT = (FIN * 2 * F) / (R * NO)$$

With the following restriction:

$$2 \text{ MHz} < FIN / R < 8 \text{ MHz}$$

$$200 \text{ MHz} < FOUT * NO < 400 \text{ MHz}$$

$$50 \text{ MHz} < FOUT < 400 \text{ MHz}$$

MPLL_F	The F parameter in the equation
MPLL_R	The R parameter in the equation
MPLL_OD	OD of PLL, determines the NO in the equation
	0 Not allowed
	1 NO = 1
	2 NO = 2
	3 NO = 4
EXT_MCLK_SEL	1 Select the external MCLK signal rather than from PLL
	0 Select the PLL output as MCLK
MPLL_OE	OE of MPLL
MPLL_BP	Bypass of MPLL

Address	[7]	[6]	[5]	[4]	[3]	[2]	[1]	[0]
0xEB8				SPLL_IREF	SPLL_CPX4		SPLL_LPX4	

SPLL_IREF	System clock PLL current control
	0 Lower current (Default)
	1 Higher current (30% more than setting to 0)
SPLL_CPX4	System clock PLL charge pump select
	0 1 uA
	1 5 uA (Default)
	2 10 uA
	3 15 uA
SPLL_LPX4	System clock PLL loop filter select
	0 80K Ohms
	1 40K Ohms (Default)
	2 30K Ohms
	3 20K Ohms

Address	[7]	[6]	[5]	[4]	[3]	[2]	[1]	[0]
0xEB9		SPLL_PD	MPLL_PD	PPLL_PD	DLL_DBG	SPLL_DBG	MPLL_DBG	PPLL_DBG

PPLL_PD	Power Down of PCLK PLL
MPLL_PD	Power Down of MPLL
SPLL_PD	Power Down of SPLL
xPLL_DBG	Reserved for internal test purpose only
DLL_DBG	Reserved for internal test purpose only

Address	[7]	[6]	[5]	[4]	[3]	[2]	[1]	[0]
0xEC0		VDOX_422	MPPVDO_SEL	RGBOUT_EN	VDOY_H_PD	VDOY_L_PD	VDOS_PD	VDOX_PD
0xEC1	DAC1_GAIN				DAC0_GAIN			
0xEC2	DACR_GAIN				DACG_GAIN			
0xEC3	V_DAC_PD	V_DAC1_PD	V_DAC0_PD	RGB_DAC_PD	DACB_GAIN			
0xEC4	EXT_VADC	EXT_AADC	A_DAC_PD	A_ADC_PD	V_ADC_PD			

VDOX_PD	1	Set VDOX to 0
	0	Enable VDOX Output
VDOS_PD	1	Set VDOS to 0
	0	Enable VDOS Output
VDOY_L_PD	1	Set VDOY[7:0] to 0
	0	Enable VDOY[7:0] Output
VDOY_H_PD	1	Set VDOY[15:8] to 0
	0	Enable VDOY[15:8] Output
RGBOUT_EN	1	Enable RGB Output on PINs shared with LVDS
	0	Disable RGB Output on PINs shared with LVDS
MPPVDO_SEL	1	Set MPP PIN output as Digital B component
	0	Set MPP PIN output as VDOX[15:8]
VDOX_422	1	Select digital display output as 422 interlaced digital video output. The VS/HS/DE is through the VGA_VS / VGA_HS / VGA_DE pins. The Y component is through the MPP_VDO (VDOX[15:8]) pins. The UV component is through VDOX[7:0] pins.
	0	Select RGB output instead.
DACxx_GAIN	The video gain control for CVBS0/1 and RGB DACs.	
xxx_PD	1	Power down the ADC / DACs to save power. This applies to V_DAC, V_DAC0, V_DAC1, A_DAC, RGB_DAC, A_ADC, V_ADC
EXT_AADC	Internal Testing feature	
EXT_VADC	Internal Testing feature	

Address	[7]	[6]	[5]	[4]	[3]	[2]	[1]	[0]
0xEC5					VGA_CLK_POL	VGA_DAC_CLK_POL	DAC0_CLK_POL	DAC1_CLK_POL
0xEC8	0			0			A_DAC_BIAS_SEL	0

- VGA\_CLK\_POL            Change the VGA output clock polarity
- VGA\_DAC\_CLK\_POL      Change the polarity of the clock used by the VGA DACs
- DAC0\_CLK\_POL          Change the polarity of the clock used by CVBS0 DAC
- DAC1\_CLK\_POL          Change the polarity of the clock used by CVBS1 DAC
- A\_DAC\_BIAS\_SEL        Bias Selection  
                           0        Use AVDD33 as the reference voltage  
                           1        Use bandgap voltage as the reference

Address	[7]	[6]	[5]	[4]	[3]	[2]	[1]	[0]
0x620	0	0	BLINK_PERIOD					

- BLINK\_PERIOD            Define the blinking time from on to off and off to on

## Register Description by Address

### Page 0: 0x000 ~ 0x0FE

#	Address	[7]	[6]	[5]	[4]	[3]	[2]	[1]	[0]
0	0x000	VDLOSS*	HLOCK*	SLOCK*	FLD*	VLOCK*	NOVIDEO*	MONO*	DET50*
1	0x010								
2	0x020								
3	0x030								

\* Read only bits

<b>VDLOSS</b>	<b>1</b>	Video not present. (sync is not detected in number of consecutive line periods specified by MISSCNT register)
	<b>0</b>	Video detected.
<b>HLOCK</b>	<b>1</b>	Horizontal sync PLL is locked to the incoming video source.
	<b>0</b>	Horizontal sync PLL is not locked.
<b>SLOCK</b>	<b>1</b>	Sub-carrier PLL is locked to the incoming video source.
	<b>0</b>	Sub-carrier PLL is not locked.
<b>FLD</b>	<b>1</b>	Even field is being decoded.
	<b>0</b>	Odd field is being decoded.
<b>VLOCK</b>	<b>1</b>	Vertical logic is locked to the incoming video source.
	<b>0</b>	Vertical logic is not locked.
<b>NOVIDEO</b>		Reserved for TEST.
<b>MONO</b>	<b>1</b>	No color burst signal detected.
	<b>0</b>	Color burst signal detected.
<b>DET50</b>	<b>0</b>	60Hz source detected
	<b>1</b>	50Hz source detected
		The actual vertical scanning frequency depends on the current standard invoked.

#	Address	[7]	[6]	[5]	[4]	[3]	[2]	[1]	[0]
0	0x001	VCR*	WKAIR*	WKAIR1*	VSTD*	NINTL*	VSHP		
1	0x011								
2	0x021								
3	0x031								

\* Read only bits

VCR	VCR signal indicator
WKAIR	Weak signal indicator 2.
WKAIR1	Weak signal indicator controlled by WKTH
VSTD	1 = Standard signal 0 = Non-standard signal
NINTL	1 = Non-interlaced signal 0 = interlaced signal
VSHP	Vertical Sharpness Control 0 = None (default) 7 = Highest **Note: VSHP must be set to '0' if COMB = 0

#	Address	[7]	[6]	[5]	[4]	[3]	[2]	[1]	[0]
0	0x006	0	0	VACTIVE_ XY[8]	VDELAY_ XY[8]	HACITIVE_XY[9:8]	HDELAY_XY[9:8]		
1	0x016								
2	0x026								
3	0x036								
0	0x002	HDELAY_XY[7:0]							
1	0x012								
2	0x022								
3	0x032								

HDELAY_XY	This 10bit register defines the starting location of horizontal active pixel for display / record path. A unit is 1 pixel. The default value is 0x00F for NTSC and 0x00A for PAL.
-----------	---

#	Address	[7]	[6]	[5]	[4]	[3]	[2]	[1]	[0]
0	0x006	0	0	VACTIVE_XY[8]	VDELAY_XY[8]	HACTIVE_XY[9:8]	HDELAY_XY[9:8]		
1	0x016								
2	0x026								
3	0x036								
0	0x003	HACTIVE_XY[7:0]							
1	0x013								
2	0x023								
3	0x033								

**HACTIVE\_XY**

This 10bit register defines the number of horizontal active pixel for display / record path. A unit is 1 pixel. The default value is decimal 720.

#	Address	[7]	[6]	[5]	[4]	[3]	[2]	[1]	[0]
0	0x006	0	0	VACTIVE_XY[8]	VDELAY_XY[8]	HACTIVE_XY[9:8]	HDELAY_XY[9:8]		
1	0x016								
2	0x026								
3	0x036								
0	0x004	VDELAY_XY[7:0]							
1	0x014								
2	0x024								
3	0x034								

**VDELAY\_XY**

This 9bit register defines the starting location of vertical active for display / record path. A unit is 1 line. The default value is decimal 6.

#	Address	[7]	[6]	[5]	[4]	[3]	[2]	[1]	[0]
0	0x006	0	0	VACTIVE_XY[8]	VDELAY_XY[8]	HACTIVE_XY[9:8]	HDELAY_XY[9:8]		
1	0x016								
2	0x026								
3	0x036								
0	0x005	VACTIVE_XY[7:0]							
1	0x015								
2	0x025								
3	0x035								

**VACTIVE\_XY**

This 9bit register defines the number of vertical active lines for display / record path. A unit is 1 line. The default value is decimal 240.

#	Address	[7]	[6]	[5]	[4]	[3]	[2]	[1]	[0]
0	0x007	HUE							
1	0x017								
2	0x027								
3	0x037								

**HUE**

These bits control the color hue as 2's complement number. They have value from +36° (7Fh) to -36° (80h) with an increment of 2.8°. The 2 LSB has no effect. The positive value gives greenish tone and negative value gives purplish tone. The default value is 0° (00h). This is effective only on NTSC system. The default is 00h.

#	Address	[7]	[6]	[5]	[4]	[3]	[2]	[1]	[0]
0	0x008	SCURVE	VSF	CTI		SHARPNESS			
1	0x018								
2	0x028								
3	0x038								

**SCURVE**

This bit controls the center frequency of the peaking filter. The corresponding gain adjustment is HFLT.

0 Low  
1 center

**VSF**

This bit is for internal used. The default is 0.

**CTI**

CTI level selection. The default is 1.

0 None  
3 Highest

**SHARPNESS**

These bits control the amount of sharpness enhancement on the luminance signals. There are 16 levels of control with '0' having no effect on the output image. 1 through 15 provides sharpness enhancement with 'F' being the strongest. The default is 1.

#	Address	[7]	[6]	[5]	[4]	[3]	[2]	[1]	[0]
0	0x009	CNRST							
1	0x019								
2	0x029								
3	0x039								

**CNRST**

These bits control the luminance contrast gain. A value of 100 (64h) has a gain of 1. The range adjustment is from 0% to 255% at 1% per step. The default is 64h.

VIN	Address	[7]	[6]	[5]	[4]	[3]	[2]	[1]	[0]
0	0x00A	BRIGHT							
1	0x01A								
2	0x02A								
3	0x03A								

**BRIGHT**

These bits control the brightness. They have value of  $-128$  to  $127$  in 2's complement form. Positive value increases brightness. A value 0 has no effect on the data. The default is 00h.

#	Address	[7]	[6]	[5]	[4]	[3]	[2]	[1]	[0]
0	0x00B	SAT_U							
1	0x01B								
2	0x02B								
3	0x03B								

**SAT\_U**

These bits control the digital gain adjustment to the U (or Cb) component of the digital video signal. The color saturation can be adjusted by adjusting the U and V color gain components by the same amount in the normal situation. The U and V can also be adjusted independently to provide greater flexibility. The range of adjustment is 0 to 200%. A value of 128 (80h) has gain of 100%. The default is 80h.

#	Address	[7]	[6]	[5]	[4]	[3]	[2]	[1]	[0]
0	0x00C	SAT_V							
1	0x01C								
2	0x02C								
3	0x03C								

**SAT\_V**

These bits control the digital gain adjustment to the V (or Cr) component of the digital video signal. The color saturation can be adjusted by adjusting the U and V color gain components by the same amount in the normal situation. The U and V can also be adjusted independently to provide greater flexibility. The range of adjustment is 0 to 200%. A value of 128 (80h) has gain of 100%. The default is 80h.



#	Address	[7]	[6]	[5]	[4]	[3]	[2]	[1]	[0]
0	0x00D	SF*	PF*	FF*	KF*	CSBAD*	MCVSN*	CSTRIPE*	CTYPE2*
1	0x01D								
2	0x02D								
3	0x03D								

\* Read only bits

SF This bit is for internal use

PF This bit is for internal use

FF This bit is for internal use

KF This bit is for internal use

CSBAD 1 Macrovision color stripe detection may be un-reliable

MCVSN 1 Macrovision AGC pulse detected.  
0 Not detected.

CSTRIPE 1 Macrovision color stripe protection burst detected.  
0 Not detected.

CTYPE2 This bit is valid only when color stripe protection is detected, i.e. if CSTRIPE=1,  
1 Type 2 color stripe protection  
0 Type 3 color stripe protection

#	Address	[7]	[6]	[5]	[4]	[3]	[2]	[1]	[0]
0	0x00E	DETSTUS*		STDNOW*		ATREG			STANDARD
1	0x01E								
2	0x02E								
3	0x03E								

\* Read only bits

<b>DETSTUS</b>	<b>0</b>	Idle
	<b>1</b>	detection in progress
<b>STDNOW</b>		Current standard invoked
	<b>0</b>	NTSC(M)
	<b>1</b>	PAL (B,D,G,H,I)
	<b>2</b>	SECAM
	<b>3</b>	NTSC4.43
	<b>4</b>	PAL (M)
	<b>5</b>	PAL (CN)
	<b>6</b>	PAL 60
	<b>7</b>	Not valid
<b>ATREG</b>	<b>1</b>	Disable the shadow registers
	<b>0</b>	Enable VACTIVE and HDELAY shadow registers value depending on STANDARD. (Default)
<b>STANDARD</b>		Standard selection
	<b>0</b>	NTSC(M)
	<b>1</b>	PAL (B,D,G,H,I)
	<b>2</b>	SECAM
	<b>3</b>	NTSC4.43
	<b>4</b>	PAL (M)
	<b>5</b>	PAL (CN)
	<b>6</b>	PAL 60
	<b>7</b>	Auto detection (Default)

#	Address	[7]	[6]	[5]	[4]	[3]	[2]	[1]	[0]
0	0x00F	ATSTART	PAL60EN	PALCNEN	PALMEN	NTSC44EN	SECAMEN	PALBEN	NTSCEN
1	0x01F								
2	0x02F								
3	0x03F								

ATSTART	1	Writing 1 to this bit will manually initiate the auto format detection process. This bit is a self-clearing bit
	0	Manual initiation of auto format detection is done. (Default)
PAL60EN	1	Enable recognition of PAL60 (Default)
	0	Disable recognition
PALCNEN	1	Enable recognition of PAL (CN). (Default)
	0	Disable recognition
PALMEN	1	Enable recognition of PAL (M). (Default)
	0	Disable recognition
NTSC44EN	1	Enable recognition of NTSC 4.43. (Default)
	0	Disable recognition
SECAMEN	1	Enable recognition of SECAM. (Default)
	0	Disable recognition
PALBEN	1	Enable recognition of PAL (B,D,G,H,I). (Default)
	0	Disable recognition
NTSCEN	1	Enable recognition of NTSC (M). (Default)
	0	Disable recognition

Address	[7]	[6]	[5]	[4]	[3]	[2]	[1]	[0]
0x045	0	0	VSMODE	FLDPOL	HSPOL	VSPOL	DECVSMODE	DECFLDPOL

<b>VSMODE</b>	Control the VS and field flag timing
0	VS and field flag is aligned with vertical sync of incoming video (Default)
1	VS and field flag is aligned with HS
<b>FLDPOL</b>	Select the FLD polarity
0	Odd field is high
1	Even field is high (Default)
<b>HSPOL</b>	Select the HS polarity
0	Low for sync duration (Default)
1	High for sync duration
<b>VSPOL</b>	Select the VS polarity
0	Low for sync duration (Default)
1	High for sync duration
<b>DECVSMODE</b>	0 Default
<b>DECFLDPOL</b>	0 Default

Address	[7]	[6]	[5]	[4]	[3]	[2]	[1]	[0]
0x046	AGCEN4	AGCEN3	AGCEN2	AGCEN1	AGCGAIN4[8]	AGCGAIN3[8]	AGCGAIN2[8]	AGCGAIN1[8]
0x047	AGCGAIN1[7:0]							
0x048	AGCGAIN2[7:0]							
0x049	AGCGAIN3[7:0]							
0x04A	AGCGAIN4[7:0]							

**AGCENn** Select Video AGC loop function on VIN of channel n  
**0** AGC loop function enabled (recommended for most application cases) (default).  
**1** AGC loop function disabled. Gain is set by AGCGAINn

**AGCGAINn** These registers control the AGC gain of channel n when AGC loop is disabled. Default value is 0F0h.

Address	[7]	[6]	[5]	[4]	[3]	[2]	[1]	[0]
0x04B	PD_BIAS	V_ADC_SAVE			0	0	0	YFLEN

**PD\_BIAS** **1** Power down the bias of all 4 VADC  
**0** Do not power down the bias

**V\_ADC\_SAVE** Power Saving Mode Selection.  
**0** Most Power Consuming  
**7** Most Power Saving

**IREF** **0** Internal current reference 1 for Video ADC (default)  
**1** Internal current reference increase 30% for Video ADC.

**VREF** **0** Internal voltage reference for Video ADC (default)  
**1** Internal voltage reference shut down for Video ADC

**YFLEN** Analog Video CH1/CH2/CH3/CH4 anti-alias filter control  
**1** Enable(default)  
**0** Disable

Address	[7]	[6]	[5]	[4]	[3]	[2]	[1]	[0]
0x04D	TST_ADC_VD1	ADC_SEL1			0	0	0	0

**TST\_ADC\_VD1** **0** Default

**ADC\_SEL1** **0** Default

Address	[7]	[6]	[5]	[4]	[3]	[2]	[1]	[0]
0x04E	TST_ADC_VD2	ADC_SEL2			0	0	0	0

**TST\_ADC\_VD2** **0** Default

**ADC\_SEL2** **0** Default

Address	[7]	[6]	[5]	[4]	[3]	[2]	[1]	[0]
0x04F	FRM		YNR		CLMD		PSP	

FRM	Free run mode control
0	Auto(default)
2	Default to 60Hz
3	Default to 50Hz
YNR	Y HF noise reduction
0	None(default)
1	Smallest
2	Small
3	Medium
CLMD	Clamping mode control
0	Sync top
1	Auto(default)
2	Pedestal
3	N/A
PSP	Slice level control
0	Low
1	Medium(default)
2	High

Address	[7]	[6]	[5]	[4]	[3]	[2]	[1]	[0]
0x050	HFLT2				HFLT1			
0x051	HFLT4				HFLT3			

HFLTn HFLTn controls the peaking function of channel n. Reserved for test purpose.

Address	[7]	[6]	[5]	[4]	[3]	[2]	[1]	[0]
0x052	CTEST	YCLLEN	0	AFLTEN	GTEST	VLPF	CKLY	CKLC

CTEST	Clamping control for debugging use. (Test purpose only) (default 0)
YCLLEN	1 Y channel clamp disabled (Test purpose only) 0 Enabled (default)
AFLTEN	1 Analog Audio input Anti-Aliasing Filter enabled (default) 0 Disabled
GTEST	1 Test (Test purpose only) 0 Normal operation (default)
VLPF	Clamping filter control (default 0)
CKLY	Clamping current control 1 (default 0)
CKLC	Clamping current control 2 (default 0)

Address	[7]	[6]	[5]	[4]	[3]	[2]	[1]	[0]
0x053	NT502	NT501						

- NT501                      1      Force the Video Decoder 1 to a special NTSC 50 Hz format  
                                  0      Do not force to NTSC 50 Hz format
- NT502                      1      Force the Video Decoder 2 to a special NTSC 50 Hz format  
                                  0      Do not force to NTSC 50 Hz format

Address	[7]	[6]	[5]	[4]	[3]	[2]	[1]	[0]
0x054	NT504	NT503	DIV_RST	DOUT_RST	ACALEN	AADC_SAVE		

- NT503                      1      Force the Video Decoder 4 to a special NTSC 50 Hz format  
                                  0      Do not force to NTSC 50 Hz format
- NT504                      1      Force the Video Decoder 4 to a special NTSC 50 Hz format  
                                  0      Do not force to NTSC 50 Hz format
- DIV\_RST                    Audio ADC divider reset. This bit must be set to 0 again after reset.
- DOUT\_RST                 Audio ADC digital output reset for all channel. This bit must be setup up to 0 again after reset.
- ACALEN                    Audio ADC Calibration control. This be must be set up to 0 again after enabled.
- AADC\_SAVE                Audio ADC Power Saving Mode. 7 is most power saving.

Address	[7]	[6]	[5]	[4]	[3]	[2]	[1]	[0]
0x055	FLD*				VAV*			

- FLD                        Status of the field flag for corresponding channel (*Read only*)  
                                  FLD[3:0] are FIELD ID for VIN3 to VIN0.  
                                  0      Odd field when FLDPOL (0x045) = 1  
                                  1      Even field when FLDPOL (0x045) = 1
- VAV                        Status of the vertical active video signal for corresponding channel (*Read only*). VAV[3:0] are Vertical Active Video Signal for VIN3 to VIN0.  
                                  0      Vertical blanking time  
                                  1      Vertical active time

Address	[7]	[6]	[5]	[4]	[3]	[2]	[1]	[0]
0x057	SHCOR				ANA_SW4	ANA_SW3	ANA_SW2	ANA_SW1

**SHCOR** These bits provide coring function for the sharpness control (default 3h)

**ANA\_SWn** Control the analog input channel switch for VIN1 to VIN4 input  
 0 VIN\_A channel is selected (default)  
 1 VIN\_B channel is selected

Address	[7]	[6]	[5]	[4]	[3]	[2]	[1]	[0]
0x058	PBW	DEM	PALSW	SET7	COMB	HCOMP	YCOMB	PDLY

**PBW** 1 Wide Chroma BPF BW (Default)  
 0 Normal Chroma BPF BW

**DEM** Reserved (Default 1)

**PALSW** 1 PAL switch sensitivity low.  
 0 PAL switch sensitivity normal (Default)

**SET7** 1 The black level is 7.5 IRE above the blank level.  
 0 The black level is the same as the blank level (Default)

**COMB** 1 Adaptive comb filter for NTSC and PAL (Recommended). This setting is not for SECAM (Default)  
 0 Notch filter. For SECAM, always set to 0.

**HCOMP** 1 Operation mode 1 (Recommended) (Default)  
 0 Mode 0

**YCOMB** 1 Bypass Comb filter when no burst presence  
 0 No bypass (Default)

**PDLY** 0 Enable PAL delay line (default)  
 1 Disable PAL delay line

Address	[7]	[6]	[5]	[4]	[3]	[2]	[1]	[0]
0x059	GMEN	CKHY		HSDLY				

**GMEN** Reserved (Default 0)

**CKHY** Color killer hysteresis.  
 0 Fastest (Default)  
 1 Fast  
 2 Medium  
 3 Slow

**HSDLY** Reserved for test



Address	[7]	[6]	[5]	[4]	[3]	[2]	[1]	[0]
0x05A	CTCOR		CCOR		VCOR		CIF	

CTCOR	These bits control the coring for CTI (Default 1h)
CCOR	These bits control the low level coring function for the Cb/Cr output (Default 0h)
VCOR	These bits control the coring function of vertical peaking (Default 1h)
CIF	These bits control the IF compensation level. 0 None(default) 1 1.5dB 2 3dB 3 6dB

Address	[7]	[6]	[5]	[4]	[3]	[2]	[1]	[0]
0x05B	CLPEND				CLPST			

CLPEND	These 4 bits set the end time of the clamping pulse. Its value should be larger than the value of CLPST (Default 5h)
CLPST	These 4 bits set the start time of the clamping. It is referenced to PCLAMP position. (Default 0h)

Address	[7]	[6]	[5]	[4]	[3]	[2]	[1]	[0]
0x05C	NMGAIN				WPGAIN			FC27

NMGAIN	These bits control the normal AGC loop maximum correction value (Default 4h)
WPGAIN	Peak AGC loop gain control (Default 1h)
FC27	1 Normal ITU-R656 operation (Default) 0 Squared Pixel mode for test purpose only

Address	[7]	[6]	[5]	[4]	[3]	[2]	[1]	[0]
0x05D	PEAKWT							

PEAKWT	These bits control the white peak detection threshold. Setting 'FF' can disable this function (Default D8h)
--------	---

Address	[7]	[6]	[5]	[4]	[3]	[2]	[1]	[0]
0x05E	CLMPLD	CLMPL						

CLMPLD                    0      Clamping level is set by CLMPL  
                                  1      Clamping level preset at 60d (Default)

CLMPL                    These bits determine the clamping level of the Y channel (Default 3Ch)

Address	[7]	[6]	[5]	[4]	[3]	[2]	[1]	[0]
0x05F	SYNCTD	SYNCT						

SYNCTD                    0      Reference sync amplitude is set by SYNCT  
                                  1      Reference sync amplitude is preset to 38h (Default)

SYNCT                    These bits determine the standard sync pulse amplitude for AGC reference (Default 38h)

Address	[7]	[6]	[5]	[4]	[3]	[2]	[1]	[0]
0x062	M_RLSWAP	RM_SYNC	RM_PBSEL		R_ADATM		R_MULTCH	

<b>M_RLSWAP</b>	<p>Define the sequence of mixing and playback audio data on the ADATM pin</p> <p>If RM_SYNC=0 : I2S format</p> <p>0     Mixing audio on position 0 and playback audio on position 8 (Default)</p> <p>1     Playback audio on position 0 and mixing audio on position 8</p> <p>If RM_SYNC=1 : DSP format</p> <p>0     Mixing audio on position 0 and playback audio on position 1 (Default)</p> <p>1     Playback audio on position 0 and mixing audio on position 1</p>
<b>RM_SYNC</b>	<p>Define the digital serial audio data format for record and mixing audio on the ACLKR, ASYNR, ADATR and ADATM pin</p> <p>0     I2S format (Default)</p> <p>1     DSP format</p>
<b>RM_PBSEL</b>	<p>Select the output PlayBackIn data for the ADATM pin</p> <p>0     First Stage PlayBackIn audio (Default)</p> <p>1     Second Stage PlayBackIn audio</p> <p>2     Third Stage PlayBackIn audio</p> <p>3     Last Stage PlayBackIn audio</p>
<b>R_ADATM</b>	<p>Select the output mode for the ADATM pin</p> <p>0     Digital serial data of mixing audio (Default)</p> <p>1     Digital serial data of ADATR format record audio</p> <p>2     Digital serial data of ADATM format record audio</p>
<b>R_MULTCH</b>	<p>Define the number of audio for record on the ADATR pin</p> <p>0     2 audios (Default)</p> <p>1     4 audios</p> <p>2     8 audios</p> <p>3     16 audios</p> <p>Number of output data are limited as shown on Sequence of Multi-channel Audio Record table. Also, each output position data are selected by R_SEQ_0/R_SEQ_1/.../R_SEQ_F registers.</p>

Address	[7]	[6]	[5]	[4]	[3]	[2]	[1]	[0]
0x063	AAUTO_MUTE	PBREFEN	VRSTSEL		FIRSTCNUM			

<b>AAUTO_MUTE</b>	<b>1</b>	When input Analog data is less than ADET_TH level, output PCM data will be set to 0. Audio DAC data input is 0x200.
	<b>0</b>	No effect
<b>PBREFEN</b>		Audio ACKG Reference (refin) input select
	<b>0</b>	ACKG has video VRST refin input selected by VRSTSEL register (Default)
	<b>1</b>	ACKG has audio ASYNP refin input
<b>VRSTSEL</b>		Select VRST(V reset) signal on ACKG (Audio Clock Generator) refin input .
	<b>0</b>	VIN0 Video Decoder Path VRST (default)
	<b>1</b>	VIN1 Video Decoder Path VRST
	<b>2</b>	VIN2 Video Decoder Path VRST
	<b>3</b>	VIN3 Video Decoder Path VRST
<b>FIRSTCNUM</b>		Set up First Stage number on audio cascade mode connection. Set up the value of (Cascade chip number-1). In 4 chips cascade case, this value is 3h for ALINK mode. In single chip application case, this doesn't need to be set up.
	<b>0</b>	(default)

Address	[7]	[6]	[5]	[4]	[3]	[2]	[1]	[0]
0x064	R_SEQ_1				R_SEQ_0			
0x065	R_SEQ_3				R_SEQ_2			
0x066	R_SEQ_5				R_SEQ_4			
0x067	R_SEQ_7				R_SEQ_6			
0x068	R_SEQ_9				R_SEQ_8			
0x069	R_SEQ_B				R_SEQ_A			
0x06A	R_SEQ_D				R_SEQ_C			
0x06B	R_SEQ_F				R_SEQ_E			

<b>R_SEQ</b>		Define the sequence of record audio on the ADATR pin. Refer to Table 15 for the detail of the R_SEQ_0 ~ R_SEQ_F. The default value of R_SEQ_0 is "0", R_SEQ_1 is "1", ... and R_SEQ_F is "F".
	<b>0</b>	AIN1
	<b>1</b>	AIN2
	<b>:</b>	<b>:</b>
	<b>:</b>	<b>:</b>
	<b>14</b>	AIN15
	<b>15</b>	AIN16

Address	[7]	[6]	[5]	[4]	[3]	[2]	[1]	[0]
0x06C	ADACEN	AADCEN	PB_MASTER	PB_LRSEL	PB_SYNC	RM_8BIT	ASYNROEN	ACLKRMAS

<b>ADACEN</b>	<b>Audio DAC Function mode</b> 0 Audio DAC function disable (test purpose only) 1 Audio DAC function enable (Default)
<b>AADCEN</b>	<b>Audio ADC Function mode</b> 0 Audio ADC function disable(test purpose only) 1 Audio ADC function enable (Default)
<b>PB_MASTER</b>	<b>Define the operation mode of the ACLKP and ASYNP pin for playback.</b> 0 All type I2S/DSP Slave mode (ACLKP and ASYNP is input) (Default) 1 TW2851 type I2S/DSP Master mode (ACLKP and ASYNP is output)
<b>PB_LRSEL</b>	<b>Select the channel for playback.</b> 0 Left channel audio is used for playback input (Default) 1 Right channel audio is used for playback input
<b>PB_SYNC</b>	<b>Define the digital serial audio data format for playback audio on the ACLKP, ASYNP and ADATP pin.</b> 0 I2S format (Default) 1 DSP format
<b>RM_8BIT</b>	<b>Define output data format per one word unit on ADATR pin.</b> 0 16bit one word unit output (Default) 1 8bit one word unit packed output
<b>ASYNROEN</b>	<b>Define input/output mode on the ASYNR pin.</b> 1 ASYNR pin is input 0 ASYNR pin is output (Default)
<b>ACLKRMAS</b>	<b>Define input/output mode on the ACLKR pin and set up audio 256xfs system processing</b> 0 ACLKR pin is input. External 256xfs clock should be connected to ACLKR pin. This function is single chip Audio slave mode only. 1 ACLKR pin is output. Internal ACKG generates 256xfs clock (Default)

Address	[7]	[6]	[5]	[4]	[3]	[2]	[1]	[0]
0x06D	LAWMD		MIX_DERATIO	MIX_MUTE				

**LAWMD** Select u-Law/A-Law/PCM/SB data output format on ADATR and ADATM pin.

- 0 PCM output (default)
- 1 SB(Signed MSB bit in PCM data is inverted) output
- 2 u-Law output
- 3 A-Law output

**MIX\_DERATIO** Disable the mixing ratio value for all audio.

- 0 Apply individual mixing ratio value for each audio (default)
- 1 Apply nominal value for all audio commonly

**MIX\_MUTE[n]** Enable the mute function for audio channel AINn when n is 0 to 3. It effects only for mixing. When n = 4, it enable the mute function of the playback audio input. It effects only for single chip or the last stage chip

- 0 Normal
- 1 Muted (default)

Address	[7]	[6]	[5]	[4]	[3]	[2]	[1]	[0]
0x06E	MIX_RATIO2				MIX_RATIO1			
0x06F	MIX_RATIO4				MIX_RATIO3			
0x070	0	0	0	0	MIX_RATIOIP			

**MIX\_RATIO<sub>n</sub>** Define the ratio values for audio mixing of channel AINn  
**MIX\_RATIOIP** Define the ratio values for audio mixing of playback audio input

If MRATIO<sub>MD</sub> = 0 (default)

- 0 0.25
- 1 0.31
- 2 0.38
- 3 0.44
- 4 0.50
- 5 0.63
- 6 0.75
- 7 0.88
- 8 1.00 (default)
- 9 1.25
- 10 1.50
- 11 1.75
- 12 2.00
- 13 2.25
- 14 2.50
- 15 2.75

If MRATIO<sub>NMD</sub> = 1, Mixing ratio is MIX\_RATIO<sub>n</sub> / 64

Address	[7]	[6]	[5]	[4]	[3]	[2]	[1]	[0]
0x071	V_ADC_CKPOL	A_ADC_CKPOL	A_DAC_CKPOL	MIX_OUTSEL				

V\_ADC\_CKPOL Test purpose only (Default 0)

A\_ADC\_CKPOL Test purpose only (Default 0)

A\_DAC\_CKPOL Test purpose only (Default 0)

MIX\_OUTSEL Define the final audio output for analog and digital mixing out.

- 0 Select record audio of channel 1
- 1 Select record audio of channel 2
- 2 Select record audio of channel 3
- 3 Select record audio of channel 4
- 4 Select record audio of channel 5
- 5 Select record audio of channel 6
- 6 Select record audio of channel 7
- 7 Select record audio of channel 8
- 8 Select record audio of channel 9
- 9 Select record audio of channel 10
- 10 Select record audio of channel 11
- 11 Select record audio of channel 12
- 12 Select record audio of channel 13
- 13 Select record audio of channel 14
- 14 Select record audio of channel 15
- 15 Select record audio of channel 16
- 16 Select playback audio of the first stage chip
- 17 Select playback audio of the second stage chip
- 18 Select playback audio of the third stage chip
- 19 Select playback audio of the last stage chip
- 20 Select mixed audio (default)
- 21 Select record audio of channel AIN51
- 22 Select record audio of channel AIN52
- 23 Select record audio of channel AIN53
- 24 Select record audio of channel AIN54

Address	[7]	[6]	[5]	[4]	[3]	[2]	[1]	[0]
0x072	AAMPMD	ADET_FILT			ADET_TH4[4]	ADET_TH3[4]	ADET_TH2[4]	ADET_TH1[4]
0x073	ADET_TH2[3:0]			ADET_TH1[3:0]				
0x074	ADET_TH4[3:0]			ADET_TH3[3:0]				

<b>AAMPMD</b>	Define the audio detection method. 0 Detect audio if absolute amplitude is greater than threshold 1 Detect audio if differential amplitude is greater than Threshold (default)
<b>ADET_FILT</b>	Select the filter for audio detection (default 4h) 0 Wide LPF : : 7 Narrow LPF
<b>ADET_THn</b>	Define the threshold value for audio detection of AINn (Default Ah) 0 Low value : : 31 High value

If fs = 8kHz Audio Clock setting mode, Registers

0x072 = 0xC0  
0x073 = 0xAA  
0x074 = 0xAA

are typical setting.

If fs=16kHz/32kHz/44.1kHz/48kHz Audio Clock setting mode, Registers

0x072 = 0xE0  
0x073 = 0xBB  
0x074 = 0xBB

are typical setting.

Address	[7]	[6]	[5]	[4]	[3]	[2]	[1]	[0]
0x075	ACKI[7:0]							
0x076	ACKI[15:8]							
0x077	0	0	ACKI[21:16]					

<b>ACKI</b>	These bits control ACKI Clock Increment in ACKG block. 09B583h for fs = 8kHz is default
-------------	--

Address	[7]	[6]	[5]	[4]	[3]	[2]	[1]	[0]
0x078	ACKN[7:0]							
0x079	ACKN[15:8]							
0x07A	0	0	0	0	0	0	ACKN[17:16]	

<b>ACKN</b>	These bits control ACKN Clock Number in ACKG block.. 000100h for Playback Slave-in lock is default.
-------------	--



Address	[7]	[6]	[5]	[4]	[3]	[2]	[1]	[0]
0x07B	0	0	SDIV					

**SDIV** These bits control SDIV Serial Clock Divider in ACKG block (Default 01h)

Address	[7]	[6]	[5]	[4]	[3]	[2]	[1]	[0]
0x07C	0	0	LRDIV					

**LRDIV** These bits control LRDIV Left/Right Clock Divider in ACKG block (Default 20h)

Address	[7]	[6]	[5]	[4]	[3]	[2]	[1]	[0]
0x07D	APZ	APG			0	ACPL	SRPH	LRPH

**APZ** These bits control Loop in ACKG block (Default 1)

**APG** These bits control Loop in ACKG block (Default 4h)

**ACPL** These bits control Loop closed/open in ACKG block  
 0 Loop closed  
 1 Loop open (recommended on typical application case) (Default)

**SRPH** Reserved. These bits are not used in TW2851 chip.

**LRPH** Reserved. These bits are not used in TW2851 chip.

Address	[7]	[6]	[5]	[4]	[3]	[2]	[1]	[0]
0x0C0	BGNDEN				BGNDCOL	AUTO_BGND	LIM_656	0

**BGNDEN[n]** Enable the background color for channel n for byte-interleave video decoder output.  
 0 Background color is disabled (Default)  
 1 Background color is enabled

**BGNDCOL** Select the background color when BGNDEN = "1" or when AUTO\_BGND = "1" and Video Loss is detected  
 0 Blue color (Default)  
 1 Black color

**AUTO\_BGND** Select the decoder background mode for byte-interleave video decoder output.  
 0 Manual background mode (Default)  
 1 Automatic background mode when No-video is detected

**LIM\_656** Clamp the Y and C value in the video stream  
 0 Maximum of Y is 254, Minimum of Y is 1  
 Maximum of C is 254, Minimum of Y is 1  
 1 Maximum of Y is 235, Minimum of Y is 16  
 Maximum of Y is 240, Minimum of Y is 16

Address	[7]	[6]	[5]	[4]	[3]	[2]	[1]	[0]
0x0C1	0	OUT_CHID	SAV_CHID	TST_EHAV_BLK	0	0	0	0

<b>TST_EHAV_BLK</b>	Testing purpose only 1 Force the Y value to be 0 when HAV is high. 0 Normal Operation
<b>OUT_CHID</b>	Enable the channel ID format in the horizontal blanking period of Record Bypass byte interleaving BT 656 stream 0 Disable the channel ID format (default) 1 Enable the channel ID format The lowest 4 bits of Y and C pixel value during horizontal blanking is Bit 3 Video Loss Bit 2 Analog Mux A/B Bit 1-0 Port ID
<b>SAV_CHID</b>	Enable the channel ID format in the SAV/EAV header in Record Bypass byte interleaving BT656 stream 0 Disable the channel ID format (default) 1 Enable the channel ID format  The SAV/EAV format is FF, 00, 00, XX When SAV_CHID is enabled, the bits in XX is  Bit 7 Detect Video Bit 1:0 Port ID

Address	[7]	[6]	[5]	[4]	[3]	[2]	[1]	[0]
0x0D0	AADC3OFS[9:8]		AADC2OFS[9:8]		AADC1OFS[9:8]		AADC0OFS[9:8]	
0x0D1	AADC0OFS[7:0]							
0x0D2	AADC1OFS[7:0]							
0x0D3	AADC2OFS[7:0]							
0x0D4	AADC3OFS[7:0]							
0x0D5	0	0	0	0	0	0	AADC4OFS[9:8]	
0x0D6	AADC4OFS[7:0]							

Digital ADC input data offset control. Digital ADC input data is adjusted by

$$ADJAADCn = AUDADCn + AADCnOFS$$

Where AUDADCn is 2's formatted Analog Audio ADC output, and AADCnOFS is adjusted offset value by 2's format. All default 10bit data value is 3EFh.

Address	[7]	[6]	[5]	[4]	[3]	[2]	[1]	[0]
0x0D7	0	ADCISEL			AUDADCn[9:8]*		ADJAADCn[9:8]*	
0x0D8	AUDADCn[7:0]*							
0x0D9	ADJAADCn[7:0]*							

<b>AUDADCn</b>	Current Analog Audio n ADC Digital Output Value by 2's format These value show the first input data value in front of Digital Audio Decimation Filtering process.										
<b>ADJAADCn</b>	Current adjusted Audio ADC Digital input data value by 2's format. These value show the first input data value in front of Digital Audio Decimation Filtering process.										
<b>ADCISEL</b>	Select AUDADCn, ADJAADCn Audio input number. AUDADCn and ADJAADCn read value shows following selected Audio input data. <table> <tbody> <tr> <td>0</td> <td>AIN1</td> </tr> <tr> <td>1</td> <td>AIN2</td> </tr> <tr> <td>2</td> <td>AIN3</td> </tr> <tr> <td>3</td> <td>AIN4</td> </tr> <tr> <td>4</td> <td>AIN5</td> </tr> </tbody> </table>	0	AIN1	1	AIN2	2	AIN3	3	AIN4	4	AIN5
0	AIN1										
1	AIN2										
2	AIN3										
3	AIN4										
4	AIN5										

Address	[7]	[6]	[5]	[4]	[3]	[2]	[1]	[0]
0x0DA	0	0	0	I2SO_RSEL				
0x0DB	0	0	0	I2SO_LSEL				
0x0DC	I2SRECSEL53		I2SRECSEL52		I2SRECSEL51		I2SRECSEL50	
0x0DD	A5OUT_OFF	ADATM_I2SOEN	MIX_MUTE_A5	ADET_TH5				

<b>A5OUT_OFF</b>	AIN5 data output control on ADATR record signal. 0 Output AIN51/AIN52/AIN53/AIN54 record data on DATR 1 Not output AIN51/AIN52/AIN53/AIN54 record data on ADATR
<b>ADATM_I2SOEN</b>	Define ADATM pin output 2 word data to make standard I2S output. 0 Output Mixing or Playback data only on ADATM pin as specified by M_RLSWAP register (Default) 1 L/R data on ADATM pin is selected by I2SO_RSEL/I2SO_LSEL registers
<b>MIX_MUTE_A5</b>	Audio input AIN5 mute function control 0 Normal 1 Muted
<b>ADET_TH5</b>	AIN5 threshold value for audio detection
<b>I2SO_RSEL/ I2SO_LSEL</b>	Select L/R output data on ADATM pin when ADATM_I2SOEN=1. Both I2SO_RSEL and I2SO_LSEL select output data by following order. 0 Select record audio of channel 1(AIN0) 1 Select record audio of channel 2(AIN1) 2 Select record audio of channel 3(AIN2) 3 Select record audio of channel 4(AIN3) 4 Select record audio of channel 5(AIN4) 5 Select record audio of channel 6(AIN5) 6 Select record audio of channel 7(AIN6) 7 Select record audio of channel 8(AIN7) 8 Select record audio of channel 9(AIN8) 9 Select record audio of channel 10(AIN9) 10(Ah) Select record audio of channel 11(AIN10) 11(Bh) Select record audio of channel 12(AIN11) 12(Ch) Select record audio of channel 13(AIN12) 13(Dh) Select record audio of channel 14(AIN13) 14(Eh) Select record audio of channel 15(AIN14) 15(Fh) Select record audio of channel 16(AIN15) 16(10h) Select playback audio of the first stage chip (PB1) 17(11h) Select playback audio of the second stage chip (PB2) 18(12h) Select playback audio of the third stage chip (PB3) 19(13h) Select playback audio of the last stage chip (PB4) 20(14h) Select mixed audio 21(15h) Select record audio of channel 51(AIN51) (default) 22(16h) Select record audio of channel 52(AIN52) 23(17h) Select record audio of channel 53(AIN53) 24(18h) Select record audio of channel 54(AIN54) Others No audio output

I2SRECSEL5n

Select output data of port n in the position below

- 0 AIN51
- 1 AIN52
- 2 AIN53
- 3 AIN54

Address	[7]	[6]	[5]	[4]	[3]	[2]	[1]	[0]
0x0DE								MIX_RATIO5

MIX\_RATIO5

Define the ratio values for audio mixing of channel AIN4 using MIX\_RATIO4 to the ratio values for audio mixing of playback audio input

If MRATIOMD = 0 (default)

- 0 0.25
- 1 0.31
- 2 0.38
- 3 0.44
- 4 0.50
- 5 0.63
- 6 0.75
- 7 0.88
- 8 1.00 (default)
- 9 1.25
- 10 1.50
- 11 1.75
- 12 2.00
- 13 2.25
- 14 2.50
- 15 2.75

If MRATIONMD = 1, Mixing ratio is MIX\_RATIO4 / 64

Address	[7]	[6]	[5]	[4]	[3]	[2]	[1]	[0]
0x0DF	ATHROUGH H	ASYNSERI AL	ACLKR128	ACLKR64	AFS384	AIN5MD	0	0

ATHROUGH Default 0

ASYNSERIAL Default 0

ACLKR128 ACLKR clock output mode for special 16x8bit (total 128bit) data interface.

0 ACLKR output is normal (Default).

1 the number of ACLKR clock per fs is 128. This function is effective with RM\_8BIT=1 8bit mode (special purpose).

ACLKR64 ACLKR clock output mode for special 4 word output interface. ACLKRMAS<sub>TER</sub>=1 mode only.

0 ACLKR output is normal (Default)

1 the number of ACLKR clock per fs is 64.

AFS384 Special Audio fs Sampling mode.

0 Audio fs Sampling mode is normal 256xfs if AIN5 = 0. (Default)

1 Audio fs Sampling mode is 384xfs mode. In this mode, AIMANU=1, A1NUM=0, A2NUM=1, A3NUM=2, A4NUM = 3, A5NUM=4 setting are needed.

AIN5MD Audio Input process mode

0 AIN1/AIN2/AIN3/AIN4 4 audio input mode. This mode is 256xfs if AFS384 = 0. In this mode, AIN5 is not used.

1 AIN1/AIN2/AIN3/AIN4/AIN5 5 audio input mode. This mode is 320xfs mode if AFS384 = 0.

Address	[7]	[6]	[5]	[4]	[3]	[2]	[1]	[0]
0x0E0	MRATIO <sub>MD</sub>	ADACTEST	0	0	0	0	0	0

MRATIO<sub>MD</sub> 1 Use a more exponential way to interpret the MRATIO. Perform the following transformation before using the ratio

0 ~ 3 => 4 ~ 7

4 ~ 7 => 8 ~ 14

8 ~ 11 => 16 ~ 28

12 ~ 15 => 32 ~ 44

0 Use the MRATIO as the ratio

ADACTEST Test feature for ADAC. Set to 0.

Address	[7]	[6]	[5]	[4]	[3]	[2]	[1]	[0]
0x0E3	0	0	ACLKRPOL	ACLKPPOL	AFAUTO	AFMD		

<b>ACLKRPOL</b>	<b>ACLKR input signal polarity inverse.</b> 0 Not inverted (Default) 1 Inversed
<b>ACLKPPOL</b>	<b>ACLKP input signal polarity inverse.</b> 0 Not inverted (Default) 1 Inversed
<b>AFAUTO</b>	<b>ACKI[21:0] control automatic set up with AFMD registers</b> This mode is only effective when <b>ACLKRMAS</b> =1 0 ACKI[21:0] registers set up ACKI control 1 ACKI control is automatically set up by AFMD register values
<b>AFMD</b>	<b>AFAUTO control mode</b> 0 8kHz setting (Default) 1 16kHz setting 2 32kHz setting 3 44.1kHz setting 4 48kHz setting

Address	[7]	[6]	[5]	[4]	[3]	[2]	[1]	[0]
0x0E4	I2S8MODE	MASCKMD	PBINSWAP	ASYNRDLY	ASYNPDLY	ADATPDLY	INLAWMD	

<b>I2S8MODE</b>	<b>8bit I2S Record output mode.</b> 0 L/R half length separated output (Default). 1 One continuous packed output equal to DSP output format.
<b>MASCKMD</b>	<b>Audio Clock Master ACLKR output wave format.</b> 0 High period is one 27MHz clock period (default). 1 Almost duty 50-50% clock output on ACLKR pin. If this mode is selected, two times bigger number value need to be set up on the ACKI register. If AFAUTO=1, ACKI control is automatically set up even if MASCKMD=1.
<b>PBINSWAP</b>	<b>Playback ACLKP/ASYNP/ADATP input data MSB-LSB swapping.</b> 0 Not swapping 1 Swapping.
<b>ASYNRDLY</b>	<b>ASYNR input signal delay.</b> 0 No delay 1 Add one 27MHz period delay in ASYNR signal input
<b>ASYNPDLY</b>	<b>ASYNP input signal delay.</b> 0 no delay 1 add one 27MHz period delay in ASYNP signal input
<b>ADATPDLY</b>	<b>ADATP input data delay by one ACLKP clock.</b> 0 No delay (Default).This is for I2S type 1T delay input interface. 1 Add 1 ACLKP clock delay in ADATP input data. This is for left-justified type 0T delay input interface.
<b>INLAWMD</b>	<b>Select u-Law/A-Law/PCM/SB data input format on ADATP pin.</b> 0 PCM input (Default) 1 SB (Signed MSB bit in PCM data is inverted) input 2 u-Law input 3 A-Law input

Address	[7]	[6]	[5]	[4]	[3]	[2]	[1]	[0]
0x0E5	0	0	0	0	0	0	AINTPOFF	A5DETENA

<b>AINTPOFF</b>	<b>Test feature for ADAC. Set to 0.</b>
<b>A5DETENA</b>	<b>Enable state register updating and interrupt request of audio AIN5 detection for each input</b> 0 Disable state register updating and interrupt request 1 Enable state register updating and interrupt request



Address	[7]	[6]	[5]	[4]	[3]	[2]	[1]	[0]
0x0E7	HASYNC		OFDLY		DECOUTMD	0	0	0

<b>HASYNC</b>	<b>1</b>	The length of EAV to SAV is set up and fixed by HBLEN register
	<b>0</b>	The length of SAV to EAV is setup and fixed by HACTIVE registers
<b>OFDLY</b>		FIELD output delay
	<b>0h</b>	0H line delay FIELD output (601 mode only)
	<b>1h~6h</b>	1H ~ 6H line delay FIELD output
	<b>7h</b>	Reserved
<b>DECOUTMD</b>		Default 1

Address	[7]	[6]	[5]	[4]	[3]	[2]	[1]	[0]
0x0E8	HBLN							

<b>HBLN</b>		These bits are effective when HASYNC bit is set to 1. These bits setup the length of EAV to SAV code when HASYNC bit is 1. Normal value is (Total pixel per line - HACTIVE) value.
		NTSC/PAL-M(60Hz)      8Ah = 858 - 720
		PAL/SECAM(50Hz)      90h = 864 - 720
		If register 0x00E[3] (ATREG for CH1) is set to 0, this value changes into 8Ah or 90h at audio video format detection initial time automatically according to CH1 video detection status.

Address	[7]	[6]	[5]	[4]	[3]	[2]	[1]	[0]
0x0E9	CKLM		YDLY		0	0	0	0

<b>CKLM</b>		Color Killer mode.
	<b>0</b>	Normal (Default)
	<b>1</b>	Fast (For special application)
<b>TDLY</b>		Luma delay fine adjustment. This 2's complement number provides -4 to +3 unit delay control (Default 3h)

Address	[7]	[6]	[5]	[4]	[3]	[2]	[1]	[0]
0x0EA	0	0	ADECRST	0	VDEC4RST	VDEC3RST	VDEC2RST	VDEC1RST

<b>ADECRST</b>		A 1 written to this bit resets the audio portion to its default state but all register content remains unchanged. This bit is self-cleared.
<b>VDECnRST</b>		A 1 written to this bit resets the VINn path Video Decoder portion to its default state but all register content remain unchanged. This bit is self cleared.

Address	[7]	[6]	[5]	[4]	[3]	[2]	[1]	[0]
0x0EB	MISSCNT				HSWIN			

**MISSCNT**                      These bits set the threshold for horizontal sync miss count threshold (Default 4h)

**HSWIN**                        These bits determine the VCR mode detection threshold (Default 4h)

Address	[7]	[6]	[5]	[4]	[3]	[2]	[1]	[0]
0x0EC	PCLAMP							

**PCLAMP**                      These bits set the clamping position from the PLL sync edge (Default 2Ah)

Address	[7]	[6]	[5]	[4]	[3]	[2]	[1]	[0]
0x0ED	VLCKI		VLCKO		VMODE	DETV	AFLD	VINT

**VLCKI**                        Vertical lock in time  
**0**                      Fastest (Default)  
**:**  
**3**                      Slowest.

**VLCKO**                        Vertical lock out time  
**0**                      Fastest (Default)  
**:**  
**3**                      Slowest

**VMODE**                      This bit controls the vertical detection window  
**1**                      Search mode  
**0**                      Vertical countdown mode (Default)

**DETV**                        **1**                      Recommended for special application only  
**0**                      Normal Vsync logic (Default)

**AFLD**                        Auto field generation control  
**0**                      Off (Default)  
**1**                      On

**VINT**                        Vertical integration time control  
**1**                      Short  
**0**                      Normal (Default)

Address	[7]	[6]	[5]	[4]	[3]	[2]	[1]	[0]
0x0EE	BSHT				VSHT			

**BSHT**                        Burst PLL center frequency control (Default 0h)

**VSHT**                        Vsync output delay control in the increment of half line length (Default 0h)

Address	[7]	[6]	[5]	[4]	[3]	[2]	[1]	[0]
0x0EF	CKILLMAX		CKILLMIN					

**CKILLMAX**                      These bits control the amount of color killer hysteresis. The hysteresis amount is proportional to the value (Default 1h)

**CKILLMIN**                      These bits control the color killer threshold. Larger value gives lower killer level (Default 28h)

Address	[7]	[6]	[5]	[4]	[3]	[2]	[1]	[0]
0x0F0	COMBMD	HTL		VTL				

**COMBMD**                      0      Adaptive mode (Default)  
    1      Fixed comb

**HTL**                              Adaptive Comb filter threshold control 1 (Default 4h)

**VTL**                              Adaptive Comb filter threshold control 2 (Default Ch)

Address	[7]	[6]	[5]	[4]	[3]	[2]	[1]	[0]
0x0F1	HPLC	EVCNT	PALC	SDET	0	BYPASS	0	0

**HPLC**                              Reserved for internal use (Default 0)

**EVCNT**                              1      Even field counter in special mode  
    0      Normal operation (Default)

**PALC**                              Reserved for future use (Default 0)

**SDET**                              ID detection sensitivity. A '1' is recommended (Default 1)

**BYPASS**                              It controls the standard detection and should be set to '1' in normal use (Default 1)

Address	[7]	[6]	[5]	[4]	[3]	[2]	[1]	[0]
0x0F2	HPM		ACCT		SPM		CBW	

HPM	Horizontal PLL acquisition time. 0 Normal 1 Auto2 2 Auto1 (Default) 3 Fast
ACCT	ACC time constant 0 No ACC 1 Slow 2 Medium (Default) 3 Fast
SPM	Burst PLL control 0 Slowest 1 Slow (Default) 2 Fast 3 Fastest
CBW	Chroma low pass filter bandwidth control. Refer to filter curves (Default 1)

Address	[7]	[6]	[5]	[4]	[3]	[2]	[1]	[0]
0x0F3	NKILL	PKILL	SKILL	CBAL	FCS	LCS	CCS	BST

NKILL	1	Enable noisy signal color killer function in NTSC mode (Default)
	0	Disabled
PKILL	1	Enable automatic noisy color killer function in PAL mode (Default)
	0	Disabled
SKILL	1	Enable automatic noisy color killer function in SECAM Mode (Default)
	0	Disabled
CBAL	0	Normal output (Default)
	1	Special output mode.
FCS	1	Force decoder output value determined by CCS
	0	Disabled (Default)
LCS	1	Enable pre-determined output value indicated by CCS when video loss is detected
	0	Disabled (Default)
CCS	When FCS is set high or video loss condition is detected when LCS is set high, one of two colors display can be selected.	
	1	Blue color
	0	Black (Default)
BST	1	Enable blue stretch
	0	Disabled (Default)

Address	[7]	[6]	[5]	[4]	[3]	[2]	[1]	[0]
0x0F4	0	0	MONITOR					
0x0F5	HREF*							

These registers are for test purpose only. The MONITOR is used to select the HREF status of a certain video decoder port in Reg0x0F5 HREF

MONITOR Value	Select video decoder port for register 0x0F5
00h	VIN0 Video Decoder Path HREF[9:2] value
10h	VIN1 Video Decoder Path HREF[9:2] value
20h	VIN2 Video Decoder Path HREF[9:2] value
30h	VIN3 Video Decoder Path HREF[9:2] value

Address	[7]	[6]	[5]	[4]	[3]	[2]	[1]	[0]
0x0F6	0		CVSTD1*					CVFMT1
0x0F7	0		CVSTD2*					CVFMT2
0x0F8	0		CVSTD3*					CVFMT3
0x0F9	0		CVSTD4*					CVFMT4

CVSTDn  
CVFMTn

Address	[7]	[6]	[5]	[4]	[3]	[2]	[1]	[0]
0x0FA		IDX1						NSEN1/SSEN1/PSEN1/WKTH1
0x0FB		IDX2						NSEN2/SSEN2/PSEN2/WKTH2
0x0FC		IDX3						NSEN3/SSEN3/PSEN3/WKTH3
0x0FD		IDX4						NSEN4/SSEN4/PSEN4/WKTH4

NSENn/SSENn/PSENn/WKTHn shared the same 6 bits in the register. IDXn is used to select which of the four parameters is being controlled. The write sequence is a two steps process unless the same register is written. A write of {ID,000000} selects one of the four registers to be written. A subsequent write will actually write into the register. (Default 0h)

IDXn	0	Controls the NTSC color carrier detection sensitivity (NSENn) (Default 1Ah)
	1	Controls the SECAM ID detection sensitivity (SSENn) (Default 20h)
	2	Controls the PAL ID detection sensitivity (PSENn) (Default 1Ch)
	3	Controls the weak signal detection sensitivity (WKTHn) (Default 2Ah)

Address	[7]	[6]	[5]	[4]	[3]	[2]	[1]	[0]
0x0FE								DEV_ID *      REV_ID *

\* Read only

DEV\_ID      The TW2851 product ID code is 01000

REV\_ID      The revision number is 0h

**Page 1: 0x100 ~ 0x1FE**

Address	[7]	[6]	[5]	[4]	[3]	[2]	[1]	[0]
0x100	0	0	LIM_PB_656	656_PB_EC_BYPASS	PB_CH_NO_VIDEO*			

\* Read only

**LIM\_PB\_656** Specify the Clamping mode for PB input data at BT 656 mode  
**1** maximum 235, minimum 16  
**0** maximum 254, minimum 1

**656\_PB\_EC\_BYPASS** Bypass the error correction of BT 656  
**1** Bypass error correction  
**0** Do not bypass error correction when the parity check is wrong

**PB\_CH\_NO\_VIDEO[n]** NO\_VIDEO Status of Playback channel n (Read Only)

Address	[7]	[6]	[5]	[4]	[3]	[2]	[1]	[0]
0x101	PB_PORT_SEL3*		PB_PORT_SEL2*		PB_PORT_SEL1*		PB_PORT_SELO*	

\* Read only

**PB\_PORT\_SELn** The playback channel n mux selection of the physical playback input port number (read only)  
**0** Channel n has input from Playback port 0  
**1** Channel n has input from Playback port 1  
**2** Channel n has input from Playback port 2  
**3** Channel n has input from Playback port 3

Address	[7]	[6]	[5]	[4]	[3]	[2]	[1]	[0]
0x102	PB1_VS_POL	PB1_HS_POL	PB1_TYPE	PBO_WIDTH	PBO_VS_POL	PBO_HS_POL	PBO_TYPE	

<b>PB1_VS_POL</b>	<b>Playback Port 1 VSYNC signal polarity control</b> 1 Reverse the polarity 0 Do not reverse the polarity
<b>PB1_HS_POL</b>	<b>Playback Port 1 HSYNC signal polarity control</b> 1 Reverse the polarity 0 Do not reverse the polarity
<b>PB1_TYPE</b>	<b>Playback Port Type Control 1 – Refer to Table 3 for PB1_TYPE setting with associated with PBO_TYPE</b> 0 BT 656 mode 1 BT 601 mode
<b>PBO_WIDTH</b>	<b>Playback Port 0 Data Width when used as component input mode (PBO_TYPE == 2'b11)</b> 1 24 bits (R/V at PB2[7:0], G/Y at PB1[7:0], B/V at PB0[7:0]) 0 16 bit mode (R/V at {PB1[1:0], PBO[7:5]}, G/Y at PB1[7:2], B/V at PBO[4:0])
<b>PBO_VS_POL</b>	<b>Playback Port 0 VSYNC signal polarity control</b> 1 Reverse the polarity 0 Do not reverse the polarity
<b>PBO_HS_POL</b>	<b>Playback Port 0 HSYNC signal polarity control</b> 1 Reverse the polarity 0 Do not reverse the polarity
<b>PBO_TYPE</b>	<b>Playback Port Type Control 0 – Refer to Table 3 for PBO_TYPE setting associated with PB1_TYPE</b> 0 BT 656 1 BT 601 2 BT 1120 3 Component (RGB/YUV) input



Address	[7]	[6]	[5]	[4]	[3]	[2]	[1]	[0]
0x103	PB0_PROG	PB0_RGB	PB_FLD_DET_MD		PB_FLD_POL			

PB0\_PROG

Port PB0 input Progressive

- 1 Port PB0 input is forced to progressive
- 0 Port PB0 input is interlaced

PB0\_RGB

- 1 Input is in RGB format
- 0 Input is in YUV format

PB\_FLD\_DET\_MODE[m]

LD Detection Mode when input port is 601 format for Port m

- 1 Field ID is derived by sample the HSYNC signal at the leading edge of VSYNC
- 0 Field ID is derived by checking the distance between the leading edge of HSYNC and VSYNC. If the distance is larger than the VS\_HS\_LAG\_TH specified in register 0x104 or 0x105, then this video field is an odd field. Otherwise it is an even field.

PB\_FLD\_POL[m]

Field Polarity Control for port m

- 1 Reverse the input field polarity
- 0 Do not reverse the input field polarity

Address	[7]	[6]	[5]	[4]	[3]	[2]	[1]	[0]
0x104	PB0_VS_HS_LAG_TH							
0x105	PB1_VS_HS_LAG_TH							

PB\_VS\_HS\_LAG\_TH

Use the VS to HS distance to determine the field ID. When this distance is larger than this threshold, the current video field is an odd field (field ID = 1'b0). Else it is even field (field ID = 1'b1). Used 8'hFF when PB\_FLD\_DET\_MODE in 0x103 is set to 0.

Address	[7]	[6]	[5]	[4]	[3]	[2]	[1]	[0]
0x106	PB0_HA_ST[7:0]							
0x107	PB0_HA_LENGTH[7:0]							
0x108	0	PB0_HA_LENGTH[10:8]			0	PB0_HA_ST[10:8]		

PB0\_HA\_ST

Specify the starting pixel of each line if PB port 0 is in BT 601 mode

PB0\_HA\_LEN

Specify the horizontal active length if PB port 0 is in BT 601 mode

Address	[7]	[6]	[5]	[4]	[3]	[2]	[1]	[0]
0x109	PBO_VA1_ST[7:0]							
0x10A	PBO_VA2_ST[7:0]							
0x10B	PBO_VA_LEN[7:0]							
0x10C	0	0	PBO_VA_LEN[9:8]		PBO_VA2_ST[9:8]		PBO_VA1_ST[9:8]	

**PBO\_VAx\_ST** Specify the starting line if PB port 0 is in BT 601 mode  
**PBO\_VA1\_ST:** The starting line of even field  
**PBO\_VA2\_ST:** The starting line of odd field

**PBO\_VA\_LEN** Specify the vertical active length if PB port 0 is in BT 601 mode

Address	[7]	[6]	[5]	[4]	[3]	[2]	[1]	[0]
0x10D	PB1_HA_ST[7:0]							
0x10E	PB1_HA_LEN[7:0]							
0x10F	0	PB1_HA_LEN[10:8]			0	PB1_HA_ST[10:8]		

**PB1\_HA\_ST** Specify the starting pixel of each line if PB port 1 is in BT 601 mode

**PB1\_HA\_LEN** Specify the horizontal active length if PB port 1 is in BT 601 mode

Address	[7]	[6]	[5]	[4]	[3]	[2]	[1]	[0]
0x110	PB1_VA1_ST[7:0]							
0x111	PB1_VA2_ST[7:0]							
0x112	PB1_VA_LEN[7:0]							
0x113	0	0	PB1_VA_LEN[9:8]		PB1_VA2_ST[9:8]		PB1_VA1_ST[9:8]	

**PB1\_VAx\_ST** Specify the starting line if PB port 1 is in BT 601 mode  
**PB1\_VA1\_ST:** The starting line of even field  
**PB1\_VA2\_ST:** The starting line of odd field

**PB1\_VA\_LEN** Specify the vertical active length if PB port1 is in BT 601 mode

Address	[7]	[6]	[5]	[4]	[3]	[2]	[1]	[0]
0x120	PBO_MAN_STRB_EN				PBO_MAN_PIC_TYPE			
0x130	PB1_MAN_STRB_EN				PB1_MAN_PIC_TYPE			
0x140	PB2_MAN_STRB_EN				PB2_MAN_PIC_TYPE			
0x150	PB3_MAN_STRB_EN				PB3_MAN_PIC_TYPE			

**PBm\_MAN\_STRB\_EN** Enable manual strobe mode for PB port m  
**1** Enable  
**0** Disable

**PBm\_MAN\_PIC\_TYPE** Specify the picture type used in manual strobe mode for PB port m

Address	[7]	[6]	[5]	[4]	[3]	[2]	[1]	[0]
0x121		PB0_MAN_CH1_ID			PB0_MAN_CH0_ID			
0x122		PB0_MAN_CH3_ID			PB0_MAN_CH2_ID			
0x131		PB1_MAN_CH1_ID			PB1_MAN_CH0_ID			
0x132		PB1_MAN_CH3_ID			PB1_MAN_CH2_ID			
0x141		PB2_MAN_CH1_ID			PB2_MAN_CH0_ID			
0x142		PB2_MAN_CH3_ID			PB2_MAN_CH2_ID			
0x151		PB3_MAN_CH1_ID			PB3_MAN_CH0_ID			
0x152		PB3_MAN_CH3_ID			PB3_MAN_CH2_ID			

**PBm\_MAN\_CHn\_ID** Specify the channel ID to be used at PB port m channel n in Manual Strobe mode

PBm\_MAN\_CHn\_ID[3:2] chip ID  
PBm\_MAN\_CHn\_ID[1:0] channel ID

Address	[7]	[6]	[5]	[4]	[3]	[2]	[1]	[0]
0x123	0	PB0_AUTO_STRB_EN	PB0_FORCE_LIVE	PB0_MAN_STRB_FLD	PB0_MAN_ANA			
0x133	0	PB1_AUTO_STRB_EN	PB1_FORCE_LIVE	PB1_MAN_STRB_FLD	PB1_MAN_ANA			
0x143	0		PB2_FORCE_LIVE	PB2_MAN_STRB_FLD	PB2_MAN_ANA			
0x153	0		PB3_FORCE_LIVE	PB3_MAN_STRB_FLD	PB3_MAN_ANA			

**PBm\_AUTO\_STRB\_EN**

Enable playback port m automatic strobe using the channel ID embedded in the VBI. Only PB0 and PB1 has channel ID decoder. PB2 and PB3 do not support audio CHID.

- 1 Enable to use the channel ID embedded in the VBI to strobe. In this mode, the Strobe signal is sent out automatically without CPU issuing a strobe signal.
- 0 Disable: Use the channel ID specified by the register 0x120 ~ 0x122, 0x130 ~ 0x132, 0x140 ~ 0x142, 0x150 ~ 0x152 to strobe.

**PBm\_FORCE\_LIVE**

Force the playback to strobe on whatever input video stream.

- 1 When this bit is set to 1, the strobe is always sent out. It will behave like a LIVE input. When this mode is on, the PBm\_MAN\_PIC\_TYPE has to be set to 0x01.
- 0 When this bit is set to 0, the strobe will be sent out only if there is a match if PB\_CHNUM with the channel ID from the VBI, or the channel ID specified in the registers in 0x120 ~ 0x122, 0x130 ~ 0x132, 0x140 ~ 0x142, 0x150 ~ 0x152.

Address	[7]	[6]	[5]	[4]	[3]	[2]	[1]	[0]
0x124	PB0_HDELAY[7:0]							
0x125	PB0_HACTIVE[7:0]							
0x126	0	PB0_HACTIVE[10:8]			0	PB0_HDELAY[10:8]		
0x134	PB1_HDELAY[7:0]							
0x135	PB1_HACTIVE[7:0]							
0x136	0	PB1_HACTIVE[10:8]			0	PB1_HDELAY[10:8]		
0x144	PB2_HDELAY[7:0]							
0x145	PB2_HACTIVE[7:0]							
0x146	0	PB2_HACTIVE[10:8]			0	PB2_HDELAY[10:8]		
0x154	PB3_HDELAY[7:0]							
0x155	PB3_HACTIVE[7:0]							
0x156	0	PB3_HACTIVE[10:8]			0	PB3_HDELAY[10:8]		

**PBn\_HDELAY** Specify the starting pixel number for cropping port n. Pixels before this pixel number are cropped. Note that this is before the further cropping based on picture type.

**PBn\_HACTIVE** Specify the active horizontal length for cropping port n. Pixels beyond the range of this horizontal length are cropped. Note that this is before the further cropping based on picture type.

Address	[7]	[6]	[5]	[4]	[3]	[2]	[1]	[0]
0x127	PB0_VDELAY[7:0]							
0x128	PB0_VACTIVE[7:0]							
0x129	PB0_AUTO_STROBE_CH_EN				PB0_VACTIVE[9:8]		PB0_VDELAY[9:8]	
0x137	PB1_VDELAY[7:0]							
0x138	PB1_VACTIVE[7:0]							
0x139	PB1_AUTO_STROBE_CH_EN				PB1_VACTIVE[9:8]		PB1_VDELAY[9:8]	
0x147	PB2_VDELAY[7:0]							
0x148	PB2_VACTIVE[7:0]							
0x149					PB2_VACTIVE[9:8]		PB2_VDELAY[9:8]	
0x157	PB3_VDELAY[7:0]							
0x158	PB3_VACTIVE[7:0]							
0x159					PB3_VACTIVE[9:8]		PB3_VDELAY[9:8]	

**PBn\_VDELAY** Specify the starting line number for cropping port n. Lines before this line number is cropped. Note that this is before the further cropping based on the picture type

**PBn\_VACTIVE** Specify the active vertical length cropping port n. Lines beyond the range of this vertical length are cropped. Note that this is before further cropping based on the picture type.

Address	[7]	[6]	[5]	[4]	[3]	[2]	[1]	[0]
0x129	PBO_AUTO_STROBE_CH_EN			PBO_VACTIVE[9:8]		PBO_VDELAY[9:8]		
0x139	PB1_AUTO_STROBE_CH_EN			PB1_VACTIVE[9:8]		PB1_VDELAY[9:8]		
0x149				PB2_VACTIVE[9:8]		PB2_VDELAY[9:8]		
0x159				PB3_VACTIVE[9:8]		PB3_VDELAY[9:8]		

**PBn\_AUTO\_STROBE\_CH\_EN[m]**

Specify whether to turn on the auto strobe for port n, on channels m. Only PB0 and PB1 have channel ID decoder. PB2 and PB3 do not support audio CHID.

Address	[7]	[6]	[5]	[4]	[3]	[2]	[1]	[0]
0x12A	0	PB0_CHID_FLD_OS	PB0_DID_EN	PB0_AID_EN	PB0_FLT_EN	PB0_RIC_EN	PB0_AUTO_CHID_DET	
0x13A	0	PB1_CHID_FLD_OS	PB1_DID_EN	PB1_AID_EN	PB1_FLT_EN	PB1_RIC_EN	PB1_AUTO_CHID_DET	

**PBm\_CHID\_FLD\_OS** The PB port m CHID line offset of even field relative to odd field.

- 2 One line more than odd field
- 1 Same offset as odd field
- 0 One line less than odd field

**PBm\_DID\_EN** Enable digital channel ID detection for the PB port m

- 1 Turn on digital channel ID decoding
- 0 Turn off digital channel ID decoding

**PBm\_AID\_EN** Enable the Analog channel ID detection for PB port m

- 1 Turn on analog channel ID detection
- 0 Turn off analog channel ID detection

**PBm\_RIC\_EN** Select the run-in clock mode for analog channel ID

- 1 Run-in clock mode
- 0 No run-in clock mode

**PBm\_FLT\_EN** Select the LPF filter mode for playback input

- 0 Bypass mode
- 1 Enable the LPF filter

**PBm\_AUTO\_CHID\_DET** Select the detection mode of Analog channel ID for playback input port m

- 0 Manual detection mode for Analog channel ID
- 1 Automatic detection mode for Analog channel ID

Address	[7]	[6]	[5]	[4]	[3]	[2]	[1]	[0]
0x12B	PB0_CHID_LINE_SIZE			PB0_CHID_V_OFST				
0x13B	PB1_CHID_LINE_SIZE			PB1_CHID_V_OFST				

**PBm\_CHID\_LINE\_SIZE** Control the line width for Analog Channel ID for playback input port m in manual detection mode (PBm\_AUTO\_CHID\_DET = 0)

0 1 line  
 1 2 lines  
 :  
 7 8 lines (Default)

**PBm\_CHID\_V\_OFST** Control the vertical starting offset from field transition for analog channel ID

0 No offset  
 :  
 8 (default)  
 :  
 31

Address	[7]	[6]	[5]	[4]	[3]	[2]	[1]	[0]
0x12C	PB0_CHID_H_OFST							
0x13C	PB1_CHID_H_OFST							

**PBm\_CHID\_H\_OFST** Define the horizontal starting offset of analog channel ID in manual detection mode (PBm\_AUTO\_CHID\_DET = 0)

Address	[7]	[6]	[5]	[4]	[3]	[2]	[1]	[0]
0x12D	0	0	PB0_VAV_CHK	PB0_ANA_CHID_BW				
0x13D	0	0	PB1_VAV_CHK	PB1_ANA_CHID_BW				

**PBm\_VAV\_CHK** Enable the channel ID detection in vertical active period

0 Enable the channel ID detection for VBI period only (default)  
 1 Enable the channel ID detection for VBI and active period

**PBm\_ANA\_CHID\_BW** Define the pixel width for each bit of analog channel ID

0 1 pixel  
 :  
 31 32 pixels

Address	[7]	[6]	[5]	[4]	[3]	[2]	[1]	[0]
0x12E	PB0_CHID_MID_VAL							
0x13E	PB1_CHID_MID_VAL							

**PBm\_CHID\_MID\_VAL** Define the slicer threshold level to detect bit “0” or bit “1” from analog channel ID (default 128)

Address	[7]	[6]	[5]	[4]	[3]	[2]	[1]	[0]
0x15F	0	0	0	0	0	0	PB_NOVID_MD	

**PB\_NOVID\_MD** Select the No-Video flag generation mode

- 0 Faster
- 1 Fast
- 2 Slow
- 3 Slower (default)

Address	[7]	[6]	[5]	[4]	[3]	[2]	[1]	[0]
0x160	0	PB_STOP0	PB_HSCL_BYPO	PB_ANA0	PB_CHNUM0			
0x170	0	PB_STOP1	PB_HSCL_BYP1	PB_ANA1	PB_CHNUM1			
0x180	0	0	PB_HSCL_BYP2	PB_ANA2	PB_CHNUM2			
0x190	0	0	PB_HSCL_BYP3	PB_ANA3	PB_CHNUM3			

**PB\_STOPn** Disable the auto strobe operation for playback channel n

- 0 Normal Operation (default)
- 1 Stop the auto strobe operation for playback channel n

**PB\_HSCL\_BYPn** Bypass the horizontal scaler for playback channel n

- 0 Normal operation
- 1 Bypass the horizontal scaler

**PB\_ANAn** The analog input selection of channel n

- 0 Select VINA
- 1 Select VINB

**PB\_CHNUMn** The playback channel ID selection

- PB\_CHNUMn[3:2] CHIP ID
- PB\_CHNUMn[1:0] Port ID

Address	[7]	[6]	[5]	[4]	[3]	[2]	[1]	[0]
0x161							PB_2X_EN0	PB_FLD_POLO
0x171							PB_2X_EN1	PB_FLD_POL1
0x181							PB_2X_EN2	PB_FLD_POL2
0x191							PB_2X_EN3	PB_FLD_POL3

**PB\_2X\_ENn** Scale up 2X horizontally for PB channel n

**PB\_FLD\_POLn** Reverse the field signal polarity of channel n

Address	[7]	[6]	[5]	[4]	[3]	[2]	[1]	[0]
0x162	0	PB_SCALE_TARGET_HSIZE0						
0x163	0	0	PB_SCALE_TARGET_VSIZE0					
0x164	0	PB_SCALE_SRC_HSIZE0						
0x165	0	0	PB_SCALE_SRC_VSIZE0					
0x172	0	0	PB_SCALE_TARGET_HSIZE1					
0x173	0	0	PB_SCALE_TARGET_VSIZE1					
0x174	0	0	PB_SCALE_SRC_HSIZE1					
0x175	0	0	PB_SCALE_SRC_VSIZE1					
0x182	0	0	PB_SCALE_TARGET_HSIZE2					
0x183	0	0	PB_SCALE_TARGET_VSIZE2					
0x184	0	0	PB_SCALE_SRC_HSIZE2					
0x185	0	0	PB_SCALE_SRC_VSIZE2					
0x192	0	0	PB_SCALE_TARGET_HSIZE3					
0x193	0	0	PB_SCALE_TARGET_VSIZE3					
0x194	0	0	PB_SCALE_SRC_HSIZE3					
0x195	0	0	PB_SCALE_SRC_VSIZE3					

**PB\_SCALE\_TARGET\_HSIZE<sub>n</sub>**

Target horizontal size of channel n after scaling. The unit is 16 pixels.

**PB\_SCALE\_TARGET\_VSIZE<sub>n</sub>**

Target vertical size of channel n after scaling. The unit is 8 lines.

**PB\_SCALE\_SRC\_HSIZE<sub>n</sub>**

Source horizontal size of channel n before scaling. The unit is 16 pixels.

**PB\_SCALE\_SRC\_VSIZE<sub>n</sub>**

Source vertical size of channel n before scaling. The unit is 8 lines.



Address	[7]	[6]	[5]	[4]	[3]	[2]	[1]	[0]
0x1A0	PB_STATUS_PORT_SEL		PB_STATUS_TYPE_SEL			PB_STATUS_MOTION_INDEX		

**PB\_STATUS\_PORT\_SEL**

Select the port number from which the status is read back at register 0x1A2 through 0x1AF

00 PB port 0  
 01 PB port 1  
 1X Reserved

**PB\_STATUS\_TYPE\_SEL**

Select the channel ID type of the status read back at register 0x1A8 through 0x1AF

000 Auto CHID  
 001 Detection CHID  
 010 User CHID  
 100 Motion ID 0  
 101 Motion ID 1  
 110 Motion ID 2  
 111 Motion ID 3

**PB\_STATUS\_MOTION\_INDEX**

Select the bit index range of playback motion channel ID read back at 0x1A8 Through 0x1AF

000 Motion ID bit [63:0]  
 001 Motion ID bit [127:64]  
 010 Motion ID bit [191:128]

Address	[7]	[6]	[5]	[4]	[3]	[2]	[1]	[0]
0x1A1					PB_CH3_AUTO_VLD*	PB_CH2_AUTO_VLD*	PB_CH1_AUTO_VLD*	PB_CH0_AUTO_VLD*

**PB\_CHn\_AUTO\_VLD** Playback Channel n auto channel ID valid status (read only)

Address	[7]	[6]	[5]	[4]	[3]	[2]	[1]	[0]
0x1A2	DET_CHID_VLD*		USR_CHID_VLD*		MOTION_CHID_VLD*			

**DET\_CHID\_VLD** The detection channel ID valid status of port m, where m is selected by PB\_STATUS\_PORT\_SEL in 0x1A0 (read only)

**USER\_CHID\_VLD** The user channel ID valid status of port m, where m is selected By PB\_STATUS\_PORT\_SEL in 0x1A0 (read only)

**MOTION\_CHID\_VLD** The motion channel ID valid status of port m, where m is selected by PB\_STATUS\_PORT\_SEL in 0x1A0 (read only)

Address	[7]	[6]	[5]	[4]	[3]	[2]	[1]	[0]
0x1A3	PB_CHID_LINE_SIZE_DET*				PB_ANA_CHID_BW_DET			

**PB\_CHID\_LINE\_SIZE\_DET**

The detected VBI line size of port m, where m is selected by PB\_STATUS\_PORT\_SEL in 0x1A0 (read only)

**PB\_ANA\_CHID\_BW\_DET**

The detected VBI pixel width of port m, where m is selected by PB\_STATUS\_PORT\_SEL in 0x1A0 (read only)

Address	[7]	[6]	[5]	[4]	[3]	[2]	[1]	[0]
0x1A4								PB_PIC_TYPE*

**PB\_PIC\_TYPE**

The detected VBI picture type of port m, where m is selected by PB\_STATUS\_PORT\_SEL in 0x1A0 (read only)

Address	[7]	[6]	[5]	[4]	[3]	[2]	[1]	[0]
0x1A5	0	0	0	0	PB_CHID_TYPE			

**PB\_CHID\_TYPE**

The detected VBI channel ID type of port m, where m is selected by PB\_STATUS\_PORT\_SEL in 0x1A0 (read only)

Address	[7]	[6]	[5]	[4]	[3]	[2]	[1]	[0]
0x1A8	CHID_STATUS0*							
0x1A9	CHID_STATUS1*							
0x1AA	CHID_STATUS2*							
0x1AB	CHID_STATUS3*							
0x1AC	CHID_STATUS4*							
0x1AD	CHID_STATUS5*							
0x1AE	CHID_STATUS6*							
0x1AF	CHID_STATUS7*							

This set of registers read back the channel ID detected in the VBI. These registers are all Read only. The PB\_STATUS\_PORT\_SEL will select the corresponding playback port status.

**PB\_STATUS\_TYPE\_SEL = 0**

CHID\_STATUS0: AUTO\_CHANNEL\_ID0

CHID\_STATUS1: AUTO\_CHANNEL\_ID1

CHID\_STATUS2: AUTO\_CHANNEL\_ID2

CHID\_STATUS3: AUTO\_CHANNEL\_ID3

CHID\_STATUS4: Bit 7:4: Vertical Location of Channel n

Bit 3:0: Horizontal Location of Channel n

CHID\_STATUS5: Bit 7:4: Playback strobe of Channel n

Bit 3:0: Playback analog path of Channel n

CHID\_STATUS6: Bit 7:4: Reserved

Bit 3:0: Field Mode of Channel n

CHID\_STATUS7: Reserved

**PB\_STATUS\_TYPE\_SEL = 1**

CHID\_STATUS0: DET\_CHANNEL\_ID[7:0] of Chip ID 0  
 CHID\_STATUS1: DET\_CHANNEL\_ID[15:8] of Chip ID 0  
 CHID\_STATUS2: DET\_CHANNEL\_ID[7:0] of Chip ID 1  
 CHID\_STATUS3: DET\_CHANNEL\_ID[15:8] of Chip ID 1  
 CHID\_STATUS4: DET\_CHANNEL\_ID[7:0] of Chip ID 2  
 CHID\_STATUS5: DET\_CHANNEL\_ID[15:8] of Chip ID 2  
 CHID\_STATUS6: DET\_CHANNEL\_ID[7:0] of Chip ID 3  
 CHID\_STATUS7: DET\_CHANNEL\_ID[15:8] of Chip ID 3

PB\_STATUS\_TYPE\_SEL = 2

CHID\_STATUS0: USER\_CHANNEL\_ID0[7:0]  
 CHID\_STATUS1: USER\_CHANNEL\_ID0[15:8]  
 CHID\_STATUS2: USER\_CHANNEL\_ID1[7:0]  
 CHID\_STATUS3: USER\_CHANNEL\_ID1[15:8]  
 CHID\_STATUS4: USER\_CHANNEL\_ID2[7:0]  
 CHID\_STATUS5: USER\_CHANNEL\_ID2[15:8]  
 CHID\_STATUS6: USER\_CHANNEL\_ID3[7:0]  
 CHID\_STATUS7: USER\_CHANNEL\_ID3[15:8]

PB\_STATUS\_TYPE\_SEL = 4      n is specified by PB\_STATUS\_MOTION\_INDEX

CHID\_STATUS0: MOTION\_CHANNEL\_ID0[64\*n+7:64\*n]  
 CHID\_STATUS1: MOTION\_CHANNEL\_ID0 [64\*n+15 : 64 \*n+8]  
 CHID\_STATUS2: MOTION\_CHANNEL\_ID0[64\*n+23 : 64 \*n+16]  
 CHID\_STATUS3: MOTION\_CHANNEL\_ID0[64\*n+31:64 \*n+24]  
 CHID\_STATUS4: MOTION\_CHANNEL\_ID0[64\*n+39:64 \*n+32]  
 CHID\_STATUS5: MOTION\_CHANNEL\_ID0[64\*n+47:64 \*n+40]  
 CHID\_STATUS6: MOTION\_CHANNEL\_ID0[64\*n+55:64 \*n+48]  
 CHID\_STATUS7: MOTION\_CHANNEL\_ID0[64\*n+63:64 \*n+56]

PB\_STATUS\_TYPE\_SEL = 5      n is specified by PB\_STATUS\_MOTION\_INDEX

CHID\_STATUS0: MOTION\_CHANNEL\_ID1[64\*n+7:64\*n],  
 CHID\_STATUS1: MOTION\_CHANNEL\_ID1[64\*n+15:64\*  
                           n+8]  
 CHID\_STATUS2: MOTION\_CHANNEL\_ID1[64\*n+23:64\* n+16]  
 CHID\_STATUS3: MOTION\_CHANNEL\_ID1[64\*n+31:64\* n+24]  
 CHID\_STATUS4: MOTION\_CHANNEL\_ID1[64\*n+39:64\* n+32]  
 CHID\_STATUS5: MOTION\_CHANNEL\_ID1[64\*n+47:64\* n+40]  
 CHID\_STATUS6: MOTION\_CHANNEL\_ID1[64\*n+55:64\* n+48]  
 CHID\_STATUS7: MOTION\_CHANNEL\_ID1[64\*n+63:64\* n+56]

PB\_STATUS\_TYPE\_SEL = 6      n is specified by PB\_STATUS\_MOTION\_INDEX

CHID\_STATUS0: MOTION\_CHANNEL\_ID2[64\*n+7:64\*n]  
 CHID\_STATUS1: MOTION\_CHANNEL\_ID2[64\*n+15:64\* n+8]  
 CHID\_STATUS2: MOTION\_CHANNEL\_ID2[64\*n+23:64\* n+16]  
 CHID\_STATUS3: MOTION\_CHANNEL\_ID2[64\*n+31:64\* n+24]  
 CHID\_STATUS4: MOTION\_CHANNEL\_ID2[64\*n+39:64\* n+32]  
 CHID\_STATUS5: MOTION\_CHANNEL\_ID2[64\*n+47:64\* n+40]  
 CHID\_STATUS6: MOTION\_CHANNEL\_ID2[64\*n+55:64\* n+48]  
 CHID\_STATUS7: MOTION\_CHANNEL\_ID2[64\*n+63:64\* n+56]

PB\_STATUS\_TYPE\_SEL = 7      n is specified by PB\_STATUS\_MOTION\_INDEX

CHID\_STATUS0: MOTION\_CHANNEL\_ID3[64\*n+7:64\*n],  
 CHID\_STATUS1: MOTION\_CHANNEL\_ID3[64\*n+15:64\* n+8]  
 CHID\_STATUS2: MOTION\_CHANNEL\_ID3[64\*n+23:64\* n+16]  
 CHID\_STATUS3: MOTION\_CHANNEL\_ID3[64\*n+31:64\* n+24]  
 CHID\_STATUS4: MOTION\_CHANNEL\_ID3[64\*n+39:64\* n+32]  
 CHID\_STATUS5: MOTION\_CHANNEL\_ID3[64\*n+47:64\* n+40]  
 CHID\_STATUS6: MOTION\_CHANNEL\_ID3[64\*n+55:64\* n+48]  
 CHID\_STATUS7: MOTION\_CHANNEL\_ID3[64\*n+63:64\* n+56]

Address	[7]	[6]	[5]	[4]	[3]	[2]	[1]	[0]
0x1C0	CVBS_SCL_HACTIVE[7:0]							
0x1C1	CVBS_SCL_VACTIVE[7:0]							
0x1C2				CVBS_SCL_VACTIVE[8]				CVBS_SCL_HACTIVE[9:8]

**CVBS\_SCL\_HACTIVE**      The horizontal active pixel number for display CVBS path downscaler

**CVBS\_SCL\_VACTIVE**      The vertical active line number for display CVBS path downscaler

Address	[7]	[6]	[5]	[4]	[3]	[2]	[1]	[0]
0x1C3	CVBS_VSCALE[7:0]							
0x1C4	CVBS_VSCALE[15:8]							
0x1C5	CVBS_ODD_SKEW				CVBS_EVEN_SKEW			
0x1C6	CVBS_HSCALE[7:0]							
0x1C7	CVBS_HSCALE[15:8]							

**CVBS\_VSCALE** The vertical scaling factor for display CVBS path downscaler. 0x1FFF is scaling factor of 1.

$CVBS\_VSCALE = \text{Input line number (CVBS\_SCL\_VACTIVE)} * 8191 / (\text{Output line number} + 1)$

**\*\*Note:** line number means the number of lines in a field

**CVBS\_HSCALE** The horizontal factor for display CVBS path downscaler. 0x1FFF is scaling factor of 1,

$CVBS\_HSCALE = \text{Input pixel number (CVBS\_SCL\_HACTIVE)} * 8191 / (\text{Output pixel number} + 1)$

**CVBS\_ODD\_SKEW** Additional vertical offset on odd fields

**CVBS\_EVEN\_SKEW** Additional vertical offset on even fields

Address	[7]	[6]	[5]	[4]	[3]	[2]	[1]	[0]
0x1C8	CVBS_LIM656	CVBS_V_OFST	CVBS_VSYNC_POL	CVBS_HSYNC_POL	CVBS_HSFLT		CVBS_VSFLT	

**CVBS\_LIM656** 1 Limit the CVBS display pixel outputs (YUV) to between 16 and 235 (Default)  
0 Limit the CVBS display pixel outputs (YUV) to between 1 and 254

**CVBS\_V\_OFST** 1 Enable using different offset for EVEN/ODD field during vertical scaling (Default)  
0 Use the same offset for EVEN/ODD field during vertical scaling

**CVBS\_VSYNC\_POL** 1 Reverse the VS polarity for CVBS display (Default)  
0 Do not reverse the VS polarity for CVBS display

**CVBS\_HSYNC\_POL** 1 Reverse the HS polarity for CVBS display (Default)  
0 Do not reverse the HS polarity for CVBS display

**CVBS\_HSFLT** Select the CVBS display horizontal downscaler anti-aliasing filter mode  
0 Full bandwidth (Default)  
1 2 MHz bandwidth  
2 1.5 MHz bandwidth  
3 1 MHz bandwidth

**CVBS\_VSFLT** Select the CVBS display vertical downscaler anti-aliasing filter mode  
0 Full bandwidth (Default)

1 0.25 line-rate bandwidth  
2,3 0.18 line-rate bandwidth

Address	[7]	[6]	[5]	[4]	[3]	[2]	[1]	[0]
0x1C9	0	0	0	0	CVBS_FLD_POL	CVBS_T_FDLY	CVBS_T_VSCL	CVBS_T_CPALDLY

**CVBS\_FLD\_POL**      1      Reverse the Display CVBS field polarity  
                          0      Do not reverse the field polarity

**CVBS\_T\_FDLY**      Set display CVBS scaler field delay mode for testing

**CVBS\_T\_VSCL**      Set display CVBS vertical scaler scaling factor to be 1 for testing

**CVBS\_T\_CPALDLY**    Set display CVBS scaler chroma delay in PAL mode

Address	[7]	[6]	[5]	[4]	[3]	[2]	[1]	[0]
0x1CA	CVBS_TEST					CVBS_SOFT_RST	CVBS_HSCL_BP	CVBS_PALDLY

**CVBS\_TEST**      0001    Enable display CVBS scaler test pattern with data valid from the pattern generator  
                          0010    Enable display CVBS scaler test pattern with data valid from the display path

**CVBS\_SOFT\_RST**    Display CVBS scaler software reset

**CVBS\_HSCL\_BP**    Bypass display CVBS horizontal scaler

**CVBS\_PALDLY**    Set PAL delay mode

Address	[7]	[6]	[5]	[4]	[3]	[2]	[1]	[0]
0x1CB	C_V_START							
0x1CC	C_V_END [7:0]							
0x1CD	C_LINE_INS							C_V_END[8]

**C\_V\_START**      Set the starting line number of active video shown in PAL mode

**C\_V\_END**      Set the end line number of active video shown in PAL mode

**C\_LINE\_INS**      Enable inserting blanking lines at the beginning and end in PAL mode

Address	[7]	[6]	[5]	[4]	[3]	[2]	[1]	[0]
0x1D0	INTERRUPT_VECT0							
0x1D1	INTERRUPT_VECT1							
0x1D2	INTERRUPT_VECT2							
0x1D3	INTERRUPT_VECT3							
0x1D4	INTERRUPT_VECT4							
0x1D5	INTERRUPT_VECT5							
0x1D6	INTERRUPT_VECT6							
0x1D7	INTERRUPT_VECT7							
0x1D8	INTERRUPT_VECT_MASK0							
0x1D9	INTERRUPT_VECT_MASK1							
0x1DA	INTERRUPT_VECT_MASK2							
0x1DB	INTERRUPT_VECT_MASK3							
0x1DC	INTERRUPT_VECT_MASK4							
0x1DD	INTERRUPT_VECT_MASK5							
0x1DE	INTERRUPT_VECT_MASK6							
0x1DF	INTERRUPT_VECT_MASK7							
0x1E0	INTERRUPT_STATUS							

**INTERRUPT\_VECTn**      Read    Read the interrupt status of the specific interrupt source  
Write    Write a '1' to that bit will clear the specific interrupt source. This clear bit will make the INTERRUPT\_VECT to become '0'

**INTERRUPT\_VECT\_MASKn**

1      Set to '1' will allow the INTERRUPT\_VECT source to show up at the output IRQ pin if the vector bit is a '1'

0      Set to '0' will disable the output to IRQ, so the MCU will ignore that source

**INTERRUPT\_STATUS[x]**

1      An INTERRUPT\_STATUS[x] of '1' means there is some source in INTERRUPT\_VECTx set to 1. The MCU can read this register before it read each of the INTERRUPT\_VECTx.

The specific interrupt vector is organized as follows:

INTERRUPT_VECT0[3:0]	Video Decoder Motion Detection, ANA_SW = 0
INTERRUPT_VECT0[7:4]	Video Decoder Motion Detection, ANA_SW = 1
INTERRUPT_VECT1[3:0]	Video Decoder Night Detection, ANA_SW = 0
INTERRUPT_VECT1[7:4]	Video Decoder Night Detection, ANA_SW = 1
INTERRUPT_VECT2[3:0]	Video Decoder Black Detection, ANA_SW = 0
INTERRUPT_VECT2[7:4]	Video Decoder Black Detection, ANA_SW = 1
INTERRUPT_VECT3[3:0]	Video Decoder NO VIDEO detection, ANA_SW = 0
INTERRUPT_VECT3[7:4]	Video Decoder NO VIDEO detection, ANA_SW = 1
INTERRUPT_VECT4[3:0]	Unused
INTERRUPT_VECT4[7:4]	Playback port CHID Detection
INTERRUPT_VECT5[3:0]	Playback port NO VIDEO

INTERRUPT_VECT5[7:4]	Detection Playback muxed channel PORT Change Detection
INTERRUPT_VECT6[0]	Display Strobe Done
INTERRUPT_VECT6[1]	Record Strobe Done
INTERRUPT_VECT6[2]	SPOT Strobe Done
INTERRUPT_VECT6[3]	Record Read/Write Switch Queue Done
INTERRUPT_VECT6[4]	SPOT Read/Write Switch Queue Done
INTERRUPT_VECT6[5]	PS2 Mouse Interrupt
INTERRUPT_VECT6[6]	OSG Bitmap Done (or Wait)
INTERRUPT_VECT6[7]	DDC Channel Interrupt
INTERRUPT_VECT7[0]	Display VGA Vstart
INTERRUPT_VECT7[1]	Display CVBS Vstart
INTERRUPT_VECT7[2]	Record Vstart
INTERRUPT_VECT7[3]	SPOT Vstart
INTERRUPT_VECT7[4]	Unused
INTERRUPT_VECT7[5]	Unused
INTERRUPT_VECT7[6]	Unused
INTERRUPT_VECT7[7]	Unused

## Page 2: 0x200 ~ 0x2FE

Address	[7]	[6]	[5]	[4]	[3]	[2]	[1]	[0]
0x200	0	0	RP_INP_FLD_POL	RP_CC_EN		0	RP_CLK_SEL	

RP_INP_FLD_POL	Reverse the field polarity for record path only
RP_CC_EN[1]	<b>1</b> Record Cascade Output Enable <b>0</b> Record Cascade Output Disable This feature is not available in TW2851 rev B2. This bit is always set to 0.
RP_CC_EN[0]	<b>1</b> Record Cascade Input Enable <b>0</b> Record Cascade Input Disable This feature is not available in TW2851 rev B2. This bit is always set to 0.
RP_CLK_SEL	Record Path Clock Selection <b>0</b> Reserved <b>1</b> 27 MHz for 1 port 656, 13.5 MHz for 2 port 656 or 601 <b>2</b> 54 MHz for 1 port 656, 27 MHz for 2 port 656 or 601 <b>3</b> 108 MHz for 1 port 656, 54 MHz for 2 port 656, 601, or 1120



Address	[7]	[6]	[5]	[4]	[3]	[2]	[1]	[0]
0x201	RP_BLANK_COLR		RP_BGND_COLR		0	RP_BLNK_DIS	0	0

- RP\_BLANK\_COLR** The blank color of the video window that does not have active video source or forced to show the blank color
- 0 Dark Gray
  - 1 Intermediate Gray
  - 2 Bright Gray
  - 3 Blue
- RP\_BGND\_COLR** The background color outside of the video window configured picture.
- 0 Dark Gray
  - 1 Intermediate Gray
  - 2 Bright Gray
  - 3 Blue
- RP\_BLNK\_DIS**
- 0 Shows blank color specified by RP\_BLANK\_COLR when NO\_VIDEO signal is detected
  - 1 shows the last image captured when the NO\_VIDEO is detected

Address	[7]	[6]	[5]	[4]	[3]	[2]	[1]	[0]
0x202	0	RP_1120		RP_601	RP_2_656	RP_LIM_656		

- RP\_1120**
- 1 Record Port output is in 1440x960 resolution
  - 0 Record Port output is in format specified by PIC\_TYPE
- RP\_601**
- 1 Record Port output is in 601 format
  - 0 Record Port output is in 656 format
- RP\_2\_656**
- 1 Record output in 656 format in 2 physical port
  - 0 Record output in single port 656 or 601 format
- RP\_LIM\_656** 656 data value clamping selection for Y
- RP\_LIM\_656[2]
- 1 Maximum is 235
  - 0 Maximum is 254
- RP\_LIM\_656[1:0]
- 4 Minimum is 1
  - 5 Minimum is 16,
  - 6 Minimum is 24
  - 7 Minimum is 32
- For C
- RP\_LIM\_656
- 0~1 Maximum 254, Minimum 1
  - 2 ~ 7 Maximum 240, Minimum 16

Note that the interface configuration changes should always be followed by a system reset in order to make the change effective.

Address	[7]	[6]	[5]	[4]	[3]	[2]	[1]	[0]
0x203	RP_H_OFFSET							
0x204	0	RP_V_OFFSET						
0x205	RP_H_SIZE[7:0]							
0x206	RP_V_SIZE[7:0]							
0x207	0	0	0	0	0	RP_V_SIZE[8]	RP_H_SIZE[9:8]	

**RP\_H\_OFFSET**            The horizontal offset of the first active pixel in the output 656/601 format

**RP\_V\_OFFSET**            The vertical offset of the first active line in the output 656/601 format

**RP\_H\_SIZE**                The horizontal active length used to show the video pictures

**RP\_V\_SIZE**                The vertical active height used to show the video pictures

Address	[7]	[6]	[5]	[4]	[3]	[2]	[1]	[0]
0x208	RP_SQ_CMD	RP_SQ_WR	RP_SQ_RW_DONE*	0	0	0	0	RP_CONFIG_DONE

**RP\_SQ\_CMD**                The command bit to start a Record Path Switch Queue read / write operation. Set to 1 to start a command. This bit will self clear.

**RP\_SQ\_WR**                Read/Write Flag for Record Path Switch Queue operation  
**1**            Write to Switch Queue  
**0**            Read from Switch Queue

**RP\_SQ\_RW\_DONE**            Read Only

**RP\_CONFIG\_DONE**            After any configuration changes are made to the record path control registers, this bit should be set to resume the record path operation.

Address	[7]	[6]	[5]	[4]	[3]	[2]	[1]	[0]
0x209	RP_SQ_DATA[7:0]							
0x20A	RP_SQ_DATA[15:8]							
0x20B	RP_SQ_DATA[23:16]							
0x20C	RP_SQ_DATA[31:24]							

RP\_SQ\_DATA0 ~ 3 are used to read/write the data from/to the record path switch queue entry when a switch queue read/write operation is performed.

In write operation, these 4 registers are written first. Then a command is issued using RP\_SQ\_CMD in 0x208 to move the data into the switching queue.

In read operation, a read command is issued using RP\_SQ\_CMD in 0x208 to move the data from switch queue into these 4 registers. The MCU can then read the entry from these registers.

The definition of each bit used in the switch queue entry is as follows.

RP_SQ_DATA[1:0]	Port ID for channel 0 (upper left window)
RP_SQ_DATA[3:2]	Chip ID for channel 0
RP_SQ_DATA[5:4]	Port ID for Channel 1 (upper right window)
RP_SQ_DATA[7:6]	Chip ID for Channel 1
RP_SQ_DATA[9:8]	Port ID for Channel 2 (Lower left window)
RP_SQ_DATA[11:10]	Chip ID for Channel 2
RP_SQ_DATA[13:12]	Port ID for Channel 3 (Lower right window)
RP_SQ_DATA[15:14]	Chip ID for Channel 3
RP_SQ_DATA[19:16]	Channel 0 ~ 3 disable bit. Bit 16 set to 1, Channel 0 is disabled. Bit 17 set to 1, Channel 1 is disabled Bit 18 set to 1, Channel 2 is disabled Bit 19 set to 1, Channel 3 is disabled
RP_SQ_DATA[22:20]	Picture Type, as shown in Figure 15
RP_SQ_DATA[23]	Strobe field type for field mode picture type. 1 Odd field 0 Even field
RP_SQ_DATA[25:24]	Field/Frame based OSD0 selection for Record Output Port 0. There will be 4 sets of OSD0 configuration information. These 2 bits selects one of the 4 sets for record output port 0. According to the setting of these 2 bits, the OSD result can change from field to field or frame to frame.
RP_SQ_DATA[27:26]	Field/Frame based OSD1 selection for Record Output Port 1. There will be 4 sets of OSD1 configuration information. These 2 bits selects one of the 4 sets for record output port 1. According to the setting of these 2 bits, the OSD result can change from field to field or frame to frame.
RP_SQ_DATA[31:28]	Reserved

Address	[7]	[6]	[5]	[4]	[3]	[2]	[1]	[0]
0x20D	RP_SQ_ADDR[7:0]							
0x20E	RP_SQ_SIZE[7:0]							
0x20F	0	RP_SQ_SIZE[10:8]			0	RP_SQ_ADDR[10:8]		

**RP\_SQ\_ADDR**      The switch queue entry address to perform the switch queue read / write command. This address is automatically incremented after the command is performed

**RP\_SQ\_SIZE**      The switch queue size.  
 1-2047:            1-2047  
 2048:              0

Address	[7]	[6]	[5]	[4]	[3]	[2]	[1]	[0]
0x210	RP_CH_EN_0	0	RP_FUNC_MD_0	RP_ANA_0	0	RP_BLNK_0	RP_MIR_V_0	RP_MIR_H_0
0x211	RP_CH_EN_1	0	RP_FUNC_MD_1	RP_ANA_1	0	RP_BLNK_1	RP_MIR_V_1	RP_MIR_H_1
0x212	RP_CH_EN_2	0	RP_FUNC_MD_2	RP_ANA_2	0	RP_BLNK_2	RP_MIR_V_2	RP_MIR_H_2
0x213	RP_CH_EN_3	0	RP_FUNC_MD_3	RP_ANA_3	0	RP_BLNK_3	RP_MIR_V_3	RP_MIR_H_3

**RP\_CH\_EN**      Channel Enable Control for each of channel 0 through 3  
 1      Enable channel  
 0      Disable channel

**RP\_FUNC\_MD**      When the Record Path is not in Switch mode, this bit specifies the record capture mode  
 1      Strobe Mode  
 0      Live Mode

**RP\_ANA**      Specify the analog input selection of each of the channel.  
 0      VINA  
 1      VINB

**RP\_BLNK**      Force the channel to display blank color  
 1      Blank  
 0      Normal video

**RP\_MIR\_V**      Control to mirror the image vertically for each channel  
 0      Do not mirror vertically  
 1      Mirror vertically

**RP\_MIR\_H**      Control to mirror the image horizontally for each channel  
 0      Do not mirror horizontally  
 1      Mirror horizontally

Address	[7]	[6]	[5]	[4]	[3]	[2]	[1]	[0]
0x214	0	0	0	0	RP_STROBE_3	RP_STROBE_2	RP_STROBE_1	RP_STROBE_0

**RP\_STROBE**      Strobe command for each channel. Once set to 1, the corresponding channel will capture one field/frame and then clear this bit.

Address	[7]	[6]	[5]	[4]	[3]	[2]	[1]	[0]
0x215	0	RP_STRB_FLD	RP_CH_CYCLE		RP_SM_EN	RP_PIC_TYPE		

RP_STRB_FLD	In non-switch mode, this bit controls which field to capture in field mode ( pic_type 0, 2, 4, 6, 7) 0 Capture Even field 1 Capture Odd field
RP_CH_CYCLE	In non-switch mode, this RP_CH_CYCLE controls how many channels to interleave when the pic_type is 0, 1, 6, and 7.  PIC_TYPE 0, 1 0 Capture and interleave channel 0, 1, 2, 3 1 Capture channel 0 2 Capture and interleave channel 0, 1 3 Capture and interleave channel 0, 1, 2  PIC_TYPE 6, 7 1 Capture channel 0, 1 2 Capture and interleave channel 0, 1, 2, 3
RP_SM_EN	1 Record Path is in Switch Queue Mode 0 Record Path is in Live or Strobe Mode
RP_PIC_TYPE	When Record Path is not in Switch Queue Mode, RP_PIC_TYPE specifies the pic_type used in LIVE/Strobe mode

Address	[7]	[6]	[5]	[4]	[3]	[2]	[1]	[0]
0x216	RP_MOTN_ID_EN	RP_DIG_ID_EN	RP_ANA_ID_EN	RP_ANA_RIC_EN	RP_AUTO_ID_EN	RP_AUTO_RPT_EN	RP_DET_ID_EN	RP_USR_ID_EN

RP_MOTN_ID_EN	1 Turn on motion information encoding 0 Do not turn on motion information encoding
RP_DIG_ID_EN	1 Turn on the digital channel ID encoding 0 Turn off the digital channel ID encoding
RP_ANA_ID_EN	1 Turn on the analog channel ID encoding 0 Turn off the analog channel ID encoding
RP_ANA_RPT_EN	1 Turn on the analog auto channel ID repeat line 0 Turn off the analog auto channel ID repeat line
RP_AUTO_ID_EN	1 Turn on the auto channel ID encoding 0 Turn off the auto channel ID encoding
RP_DET_ID_EN	1 Turn on the detection ID encoding 0 Turn off the detection ID encoding
RP_USR_ID_EN	1 Turn on the user information encoding 0 Turn off the user information encoding

Address	[7]	[6]	[5]	[4]	[3]	[2]	[1]	[0]
0x217	RP_ANA_CHID_H_OFST							

**RP\_ANA\_CHID\_H\_OFST**

The horizontal starting offset for Analog Channel ID

Address	[7]	[6]	[5]	[4]	[3]	[2]	[1]	[0]
0x218	RP_ANA_CHID_HIGH							
0x219	RP_ANA_CHID_LOW							

**RP\_ANA\_CHID\_HIGH** Pixel values bigger than this setting are interpreted as "1" for Analog Channel ID (default: 235)

**RP\_ANA\_CHID\_LOW** Pixel values smaller than this setting are interpreted as "0" for Analog Channel ID (default: 16)

Address	[7]	[6]	[5]	[4]	[3]	[2]	[1]	[0]
0x21A	RP_CHID_V_OFSTO	0		RP_CHID_V_OFST				
0x21B	RP_CHID_V_OFSTE	RP_USR_ID_PT_SEL	RP_ANA_CHID_BW					

**RP\_CHID\_V\_OFSTO** Control the vertical starting offset on top of RP\_CHID\_V\_OFST in odd field for Analog Channel ID

**RP\_CHID\_V\_OFSTE** Control the vertical starting offset on top of RP\_CHID\_V\_OFST in even field for Analog Channel ID

**RP\_CHID\_V\_OFST** Vertical starting offset for Analog Channel ID. The actual vertical line offset is  $RP\_CHID\_V\_OFST + RP\_CHID\_V\_OFSTO$  or  $RP\_CHID\_V\_OFST + RP\_CHID\_V\_OFSTE$

**RP\_ANA\_CHID\_BW** Control the pixel width of each bit for Analog Channel ID  
 0 1 pixel  
 : :  
 31 32 pixels (default)

**RP\_USER\_ID\_PT\_SEL** This bit is used to select the user channel ID registers in 0x220 ~ 0x227 information is to be used for either record port 0 or 1  
 0 0x220 ~ 0x227 are used for record port 0  
 1 0x220 ~ 0x227 are used for record port 1

Address	[7]	[6]	[5]	[4]	[3]	[2]	[1]	[0]
0x21C		RP_SMALL_FR	RP_BI_CLK	RP_BYPASS	RP_GEN_CTL			

**RP\_GEN\_CTL** Internal test function

**RP\_BYPASS** Enable bypass from video decoder to record output pin with byte-interleaving format  
 0 Disable bypass  
 1 Enable bypass

**RP\_BI\_CLK** Use 27 MHz CLK0Y and CLK0YB for Byte Interleaving Output. This bit is valid only when RP\_BYPASS is set to 1.  
 0 27 MHz

## 1 54 MHz

## RP\_SMALL\_FR Internal test function

Address	[7]	[6]	[5]	[4]	[3]	[2]	[1]	[0]
0x21D	RP_CHNUM1				RP_CHNUM0			
0x21E	RP_CHNUM3				RP_CHNUM2			
0x21F								RP_GEN_FLDPOL

**RP\_CHNUM** The Channel Number to display in non-switch mode  
 [3:2] CHIP ID  
 [1:0] PORT ID

**RP\_GEN\_FLDPOL** Reverse the field polarity of the internal pattern generator for RP path.

Address	[7]	[6]	[5]	[4]	[3]	[2]	[1]	[0]
0x220	RP_USER_CHID[7:0]							
0x221	RP_USER_CHID[15:8]							
0x222	RP_USER_CHID[23:16]							
0x223	RP_USER_CHID[31:24]							
0x224	RP_USER_CHID[39:32]							
0x225	RP_USER_CHID[47:40]							
0x226	RP_USER_CHID[55:48]							
0x227	RP_USER_CHID[63:56]							

**RP\_USER\_CHID** Used to set the USER Channel ID for record path. Depending on the RP\_USER\_ID\_PT\_SEL (0x21B bit 5), these can be used to read/write the user channel ID for record port 0, or record port 1. Always set RP\_USER\_ID\_PT\_SEL before any read/write to these registers

Address	[7]	[6]	[5]	[4]	[3]	[2]	[1]	[0]
0x228	RP_HALF_LINE[7:0]							
0x229	RP_HALF_LINE[9:8]			RP_HS_P_OS				
0x22A	RP_HS_WIDTH							

**RP\_HALF\_LINE** This defines in number of clock cycles from VS edge to the location of field change, in case it is change in middle of a line

**RP\_HS\_P\_OS** HSYNC starting location, in number of clock cycles

**RP\_HS\_WIDTH** HSYNC width, in number of clock cycles

Address	[7]	[6]	[5]	[4]	[3]	[2]	[1]	[0]
0x22B								RP_TOP_VS_END
0x22C								RP_BOT_VS_END
0x22D	RP_T_VS_POS							RP_TOP_VS_OS
0x22E	RP_B_VS_PS							RP_BOT_VS_OS

RP_TOP_VS_END	VSYNC trailing edge location of top field, in number of lines
RP_BOT_VS_END	VSYNC trailing edge location of bottom field, in number of lines
RP_TOP_VS_OS	VSYNC leading edge location of top field, in number of lines
RP_BOT_VS_OS	VSYNC leading edge location of bottom field, in number of lines
RP_T_VS_POS	Enable the top field vsync edge at the middle of a line
RP_B_VS_POS	Enable the bottom field vsync edge at the middle of a line

Address	[7]	[6]	[5]	[4]	[3]	[2]	[1]	[0]
0x22F			RP_HS_POL	RP_VS_POL	RP_FLD_POL	RP_VAV_POL	RP_HAV_POL	RP_656_ERRCHK

RP_HS_POL	Output HSYNC polarity control
RP_VS_POL	Output VSYNC polarity control
RP_FLD_POL	Output FIELD polarity control
RP_VAV_POL	Output VAV polarity control
RP_HAV_POL	Output HAV polarity control
RP_656_ERRCHK	Enable 656 SAV/EAV error check



Address	[7]	[6]	[5]	[4]	[3]	[2]	[1]	[0]
0x230	DP_BLANK_COLR				DP_BGND_COLR			

## DP\_BLANK\_COLR[3]

- 1 Blue
- 0 Gray, the gray level is selected by DP\_BLANK\_COLR[2:0]

## DP\_BLANK\_COLR[2:0]

- 0 ~ 3 Black
- 4 Gray darkest
- 5 Gray darker
- 6 Gray lighter
- 7 Gray lightest

## DP\_BGND\_COLR[3]

- 1 Blue
- 0 Gray, the gray level is selected by DP\_BGND\_COLR[2:0]

## DP\_BGND\_COLR[2:0]

- 0 ~ 3 Black
- 4 Gray darkest
- 5 Gray darker
- 6 Gray lighter
- 7 Gray lightest

Address	[7]	[6]	[5]	[4]	[3]	[2]	[1]	[0]
0x231	DP_LIM_656		DP_CVBS_VSPOL			DP_FIELD_ID	DP_WINWIDTH	

## DP\_LIM\_656

## 656 Data Clamping

For Y:

- DP\_LIM\_656[2]
- 0 Maximum limit to 254
- 1 Maximum limit to 235

## DP\_LIM\_656[1:0]

- 0 Minimum set to 1
- 1 Minimum set to 16
- 2 Minimum set to 24
- 3 Minimum set to 32

For C

## DP\_LIM\_656

- 0 Maximum 254, Minimum 1
- 1~7 Maximum 240, Minimum 16

## DP\_CVBS\_VSPOL

- 0 Do not reverse the VS polarity for CVBS
- 1 Reverse the VS polarity for CVBS

## DP\_FIELD\_ID

- 1 Force the output to de-interlacer to top field
- 0 Do not force field ID to top field

## DP\_WINWIDTH

- 1 1440 pixels maximum per line
- 0 720 pixels maximum per line

Address	[7]	[6]	[5]	[4]	[3]	[2]	[1]	[0]
0x232	DP_SOFRST	DP_DI_FLDPOL	0	0	0	0	0	0

**DP\_SOFRST**                      1      Reset Display Path  
    0      Do not reset the display path

**DP\_DI\_FLDPOL**                1      Reverse the field polarity to the VGA de-interlacer  
    0      Do not reverse the field polarity to the de-interlacer

Address	[7]	[6]	[5]	[4]	[3]	[2]	[1]	[0]
0x237	DP_CAS_IN_EN							

**DP\_CAS\_IN\_EN**                Enable the display cascade input

Address	[7]	[6]	[5]	[4]	[3]	[2]	[1]	[0]
0x238							1	0

Reserved

Address	[7]	[6]	[5]	[4]	[3]	[2]	[1]	[0]
0x23A	DP_BORDER_BLINK							

**DP\_BORDER\_BLINK**        1      Turn on border blinking for the corresponding window 0  
                         ~ 7  
    0      Turn off border blinking

Address	[7]	[6]	[5]	[4]	[3]	[2]	[1]	[0]
0x23B						DP_VGA_FLDPOL	DP_CVBS_FLDPOL	DP_VD_FLDPOL

**DP\_VGA\_FLDPOL**                Reverse the field polarity for the display VGA output

**DP\_CVBS\_FLDPOL**              Reverse the field polarity for the display CVBS output

**DP\_VD\_FLDPOL**                Reverse the field polarity of the incoming video stream

Address	[7]	[6]	[5]	[4]	[3]	[2]	[1]	[0]
0x23C	DP_FREEZEOPT[7:0]							
0x23D	DP_ADAPT_EN[7:0]							

**DP\_FREEZEOPT**                0      Display field only when freeze command is issued or  
                         underflow condition occurs  
                         1      Display frame when freeze command is issued or  
                         underflow condition occurs

**DP\_ADAPT\_EN**                0      Display field/frame according to DP\_FREEZEOPT  
                         1      Overwrite DP\_FREEZEOPT and display frame when  
                         no\_motion is asserted

Address	[7]	[6]	[5]	[4]	[3]	[2]	[1]	[0]
0x23E	NON_REALTIME[7:0]							
0x23F	FRCE_BLNK_SEL	FRCE_BLNK_GRY_LVL						NON_REALTIME[8]

**NON\_REALTIME[n]**      0      Display non-real-time video source at display window n, n = 0 ~ 8. n equals 8 specifies the display cascade input.  
                                  1      Display real-time Video Sources at display window n, n = 0 ~ 8. n equals 8 specifies the display cascade input.

**FRCE\_BLNK\_GRY\_LVL**      These bit only work when the DP\_BLNKm Register bit is set (0x250[0], 0x258[0], ....., etc.)

0xx      Black  
 100      25% Gray  
 101      40% Gray  
 110      75% Gray  
 111      100% Gray

**FRCE\_BLNK\_SEL** This bit only work when the DP\_BLNKm Register bit is set (0x250[0], 0x258[0], ... , etc.)

0      Gray  
 1      Blue

Address	[7]	[6]	[5]	[4]	[3]	[2]	[1]	[0]
0x240	DP_VGA_HDELAY[7:0]							
0x241	DP_VGA_HACTIVE[7:0]							
0x242		DP_VGA_HACTIVE[10:8]				DP_VGA_HDELAY[10:8]		
0x243	DP_VGA_VDELAY[7:0]							
0x244	DP_VGA_VACTIVE[7:0]							
0x245		DP_VGA_VACTIVE[10:8]				DP_VGA_VDELAY[10:8]		

**DP\_VGA\_HDELAY**      VGA Cropping HDELAY

**DP\_VGA\_HACTIVE**      VGA Cropping HACTIVE

**DP\_VGA\_VDELAY**      VGA Cropping VDELAY

**DP\_VGA\_VACTIVE**      VGA Cropping VACTIVE

Address	[7]	[6]	[5]	[4]	[3]	[2]	[1]	[0]
0x24C	DP_BORDER_COLR			0	DP_PBVD_SEL			

**DP\_BORDER\_COLR**      Select the color of the display window border

**DP\_PBVD\_SEL**      Select the source of display window 0 ~ 3 to be from PB\_CHO ~ PB\_CH3 or from video decoders VDO ~ VD3

0      PB  
 1      VD

Address	[7]	[6]	[5]	[4]	[3]	[2]	[1]	[0]
---------	-----	-----	-----	-----	-----	-----	-----	-----

0x24D	DP_CHNAB_SEL
-------	--------------

**DP\_CHNAB\_SEL**      Select the Analog Switch A/B for each window 0 ~ 7

Address	[7]	[6]	[5]	[4]	[3]	[2]	[1]	[0]
0x24E	DP_BORDER_EN							

**DP\_BORDER\_EN**      Enable display window borders for each window 0 ~ 7

Address	[7]	[6]	[5]	[4]	[3]	[2]	[1]	[0]
0x24F	DP_STRB_REQ							

**DP\_STRB\_REQ**      Strobe Request to each of the 8 windows. Self clear after the strobe is done

Address	[7]	[6]	[5]	[4]	[3]	[2]	[1]	[0]
0x250	DP_CH_EN0	DP_FREEZE0	DP_STRB_FLD0		DP_FUNC_MD0		DP_RD_V_2X0	DP_BLNK0
0x258	DP_CH_EN1	DP_FREEZE1	DP_STRB_FLD1		DP_FUNC_MD1		DP_RD_V_2X1	DP_BLNK1
0x260	DP_CH_EN2	DP_FREEZE2	DP_STRB_FLD2		DP_FUNC_MD2		DP_RD_V_2X2	DP_BLNK2
0x268	DP_CH_EN3	DP_FREEZE3	DP_STRB_FLD3		DP_FUNC_MD3		DP_RD_V_2X3	DP_BLNK3
0x270	DP_CH_EN4	DP_FREEZE4	DP_STRB_FLD4		DP_FUNC_MD4		DP_RD_V_2X4	DP_BLNK4
0x278	DP_CH_EN5	DP_FREEZE5	DP_STRB_FLD5		DP_FUNC_MD5		DP_RD_V_2X5	DP_BLNK5
0x280	DP_CH_EN6	DP_FREEZE6	DP_STRB_FLD6		DP_FUNC_MD6		DP_RD_V_2X6	DP_BLNK6
0x288	DP_CH_EN7	DP_FREEZE7	DP_STRB_FLD7		DP_FUNC_MD7		DP_RD_V_2X7	DP_BLNK7

<b>DP_CH_ENm</b>	<b>1</b>	Enable window m
	<b>0</b>	Disable window m
<b>DP_FREEZE<sub>m</sub></b>	<b>1</b>	Freeze window m
	<b>0</b>	Do not freeze window m
<b>DP_STRB_FLD<sub>m</sub></b>	<b>0</b>	Strobe at Odd Field
	<b>1</b>	Strobe at Even Field
	<b>2/3</b>	Strobe at Frame
<b>DP_FUNC_MD<sub>m</sub></b>	<b>0</b>	LIVE Mode
	<b>1</b>	Strobe Mode
	<b>2/3</b>	Reserved
<b>DP_RD_V_2X<sub>m</sub></b>	<b>1</b>	Scale Up 2X vertically (For CIF becoming D1)
	<b>0</b>	Do not scale up 2X
<b>DP_BLNK<sub>m</sub></b>	<b>1</b>	Force the window m to display blank color
	<b>0</b>	Show normal video in the window m

Address	[7]	[6]	[5]	[4]	[3]	[2]	[1]	[0]
0x251					DP_OVWR_V2X0	DP_MIR_H_0	DP_MIR_V_0	
0x259					DP_OVWR_V2X1	DP_MIR_H_1	DP_MIR_V_1	
0x261					DP_OVWR_V2X2	DP_MIR_H_2	DP_MIR_V_2	
0x269					DP_OVWR_V2X3	DP_MIR_H_3	DP_MIR_V_3	
0x271					DP_OVWR_V2X4	DP_MIR_H_4	DP_MIR_V_4	
0x279					DP_OVWR_V2X5	DP_MIR_H_5	DP_MIR_V_5	
0x281					DP_OVWR_V2X6	DP_MIR_H_6	DP_MIR_V_6	
0x289					DP_OVWR_V2X7	DP_MIR_H_7	DP_MIR_V_7	

**DP\_OVWR\_V2X** Force V2X write, instead of following pic\_type. I.e., write even line to top field, and odd line to bottom field.

**DP\_MIR\_H\_n**      **1**      Mirror horizontally  
**0**      Do not mirror horizontally

**DP\_MIR\_V\_n**      **1**      Mirror vertically  
**0**      Do not mirror vertically

Address	[7]	[6]	[5]	[4]	[3]	[2]	[1]	[0]
0x252					DP_PICHL0[7:0]			
0x253					DP_PICHR0[7:0]			
0x254					DP_PICVT0			
0x255					DP_PICVB0			
0x256		0		DP_PICHR0[8]				DP_PICHL0[8]
0x25A					DP_PICHL1[7:0]			
0x25B					DP_PICHR1[7:0]			
0x25C					DP_PICVT1			
0x25D					DP_PICVB1			
0x25E		1		DP_PICHR1[8]				DP_PICHL1[8]
0x262					DP_PICHL2[7:0]			
0x263					DP_PICHR2[7:0]			
0x264					DP_PICVT2			
0x265					DP_PICVB2			
0x266		2		DP_PICHR2[8]				DP_PICHL2[8]
0x26A					DP_PICHL3[7:0]			
0x26B					DP_PICHR3[7:0]			
0x26C					DP_PICVT3			
0x26D					DP_PICVB3			
0x26E		3		DP_PICHR3[8]				DP_PICHL3[8]
0x272					DP_PICHL4[7:0]			
0x273					DP_PICHR4[7:0]			
0x274					DP_PICVT4			
0x275					DP_PICVB4			
0x276		4		DP_PICHR4[8]				DP_PICHL4[8]
0x27A					DP_PICHL5[7:0]			
0x27B					DP_PICHR5[7:0]			
0x27C					DP_PICVT5			
0x27D					DP_PICVB5			
0x27E		5		DP_PICHR5[8]				DP_PICHL5[8]
0x282					DP_PICHL6[7:0]			
0x283					DP_PICHR6[7:0]			
0x284					DP_PICVT6			

Address	[7]	[6]	[5]	[4]	[3]	[2]	[1]	[0]
0x285	DP_PICVB6							
0x286	6		DP_PICHR6[8]				DP_PICHL6[8]	
0x28A	DP_PICHL7[7:0]							
0x28B	DP_PICHR7[7:0]							
0x28C	DP_PICVT7							
0x28D	DP_PICVB7							
0x28E	7		DP_PICHR7[8]				DP_PICHL7[8]	

- DP\_PICHLm**            The left edge horizontal location of window m in unit of 16 pixels
- DP\_PICHRm**            The right edge horizontal location of window m in unit of 16 pixels
- DP\_PICVTm**            The upper edge vertical location of window m in unit of 8 lines
- DP\_PICVBm**            The lower edge vertical location of window m in unit of 8 lines
- DP\_PRIIm**            The window m priority when they overlap with each other. 0 has the top priority, while 7 has the least priority

Address	[7]	[6]	[5]	[4]	[3]	[2]	[1]	[0]
0x257			DP_WR_CH_EN[8]				DP_WR_EN	
0x267	DP_WR_CH_EN[7:0]							

- DP\_WR\_EN**            Enable write to the display buffer. This bit is combined with DP\_WR\_CH\_EN ({0x257[4], 0x267[7:0]}) for the per window control. I.e., use DP\_WR\_CH\_EN to select which windows will be controlled, and then use DP\_WR\_EN to do the actual enable / disable.
- DP\_WR\_CH\_EN** {0x257[4], 0x267[7:0]} controls per-window display write buffer control. These bit work together with 0x257[0].

Address	[7]	[6]	[5]	[4]	[3]	[2]	[1]	[0]
0x27F	DP_BASE_ADDR							

- DP\_BASE\_ADDR**            The base address of the display buffer. In unit of 128 Kbytes  
The DDR address generated with DP\_BASE\_ADDR is {DP\_BASE\_ADDR, 17'h0}

Address	[7]	[6]	[5]	[4]	[3]	[2]	[1]	[0]
0x28F	DP_TEST							

- DP\_TEST**            Default 0

Address	[7]	[6]	[5]	[4]	[3]	[2]	[1]	[0]
0x290	0	0	SP_INP_FLD_POL	SP_CC_EN				

- SP\_INP\_FLD\_POL** Reverse the field polarity for spot path only
- SP\_CC\_EN[1]**  
**1** SPOT Cascade Output Enable  
**0** SPOT Cascade Output Disable
- SP\_CC\_EN[0]**  
**1** SPOT Cascade Input Enable. The SPOT clock is the clock from SPOT cascade input clock.  
**0** SPOT Cascade Input Disable. The SPOT clock is a 27 MHz clock generated internally.

Address	[7]	[6]	[5]	[4]	[3]	[2]	[1]	[0]
0x291	SP_BLANK_COLR		SP_BGND_COLR		SP_BLANK_MODE		SP_BORDER_EN	0

- SP\_BLANK\_COLR** The blank color of the video window that does not have active video source or forced to show the blank color  
**0** Dark Gray  
**1** Intermediate Gray  
**2** Bright Gray  
**3** Blue
- SP\_BGND\_COLR** The background color outside of the video window configured picture.  
**0** Dark Gray  
**1** Intermediate Gray  
**2** Bright Gray  
**3** Blue
- SP\_BLANK\_MODE**  
**0** Show blank color as specified by SP\_BLANK\_COLR When the NO\_VIDEO is detected  
**1** Shows the last image captured when the NO\_VIDEO is detected  
**2** Display blank color specified by SP\_BLANK\_COLR with border blinking when NO\_VIDEO is detected (valid only if SP\_BORDER\_EN is on)  
**3** Display the last image captured with border blinking when the NO\_VIDEO is detected (valid only if SP\_BORDER\_EN is on)
- SP\_BORDER\_EN**  
**1** Enable displaying SPOT border  
**0** Disable displaying SPOT border

Address	[7]	[6]	[5]	[4]	[3]	[2]	[1]	[0]
0x292	SP_BORDER_COLR			0	0	SP_LIM_656		

**SP\_LIM\_656**                      656 data value clamping selection  
For Y

**SP\_LIM\_656[2]**  
1        Maximum is 235  
0        Maximum is 254

**SP\_LIM\_656[1:0]**  
0        Minimum is 1  
1        Minimum is 16,  
2        Minimum is 24  
3        Minimum is 32

For C

**SP\_LIM\_656**  
0~1     Maximum 254, Minimum 1  
2 ~ 7    Maximum 240, Minimum 16

**SP\_BORDER\_COLR**

0        Black  
1        Dark gray  
2        Light gray  
3        White

Address	[7]	[6]	[5]	[4]	[3]	[2]	[1]	[0]
0x293	SP_H_OFFSET							
0x294	0	SP_V_OFFSET						
0x295	SP_H_SIZE[7:0]							
0x296	SP_V_SIZE[7:0]							
0x297	0	0	0	0	0	SP_V_SIZE[8]	SP_H_SIZE[9:8]	

**SP\_H\_OFFSET**                      The horizontal offset of the first active pixel in the output 656/601 format

**SP\_V\_OFFSET**                      The vertical offset of the first active line in the output 656/601 format

**SP\_H\_SIZE**                         The horizontal active length used to show the video pictures

**SP\_V\_SIZE**                         The vertical active height used to show the video pictures



Address	[7]	[6]	[5]	[4]	[3]	[2]	[1]	[0]
0x298	SP_SQ_CMD	SP_SQ_WR	SP_SQ_RW_DONE*	0	0	0	0	SP_CONFIG_DONE

<b>SP_SQ_CMD</b>	The command bit to start a SPOT Path Switch Queue read / write operation. Set to 1 to start a command. This bit will self clear.
<b>SP_SQ_WR</b>	Read/Write Flag for SPOT Path Switch Queue operation <b>1</b> Write to Switch Queue <b>0</b> Read from Switch Queue
<b>SP_SQ_RW_DONE</b>	Read Only
<b>SP_CONFIG_DONE</b>	After any configuration changes are made to the control registers, this bit should be set to resume the SPOT path operation.

Address	[7]	[6]	[5]	[4]	[3]	[2]	[1]	[0]
0x299	SP_SQ_DATA[7:0]							
0x29A	SP_SQ_DATA[15:8]							
0x29B	SP_SQ_DATA[23:16]							

SP\_SQ\_DATA are used to read/write the data from/to the SPOT path switch queue entry when a switch queue read/write operation is performed.

In write operation, these 4 registers are written first. Then a command is issued using SP\_SQ\_CMD in 0x298 to move the data into the switching queue.

In read operation, a read command is issued using SP\_SQ\_CMD in 0x298 to move the data from switch queue into these 4 registers. The MCU can then read the entry from these registers.

The definition of each bit used in the switch queue entry is as follows.

SP_SQ_DATA[1:0]	Port ID for channel 0 (upper left window)
SP_SQ_DATA[3:2]	Chip ID for channel 0
SP_SQ_DATA[5:4]	Port ID for Channel 1 (upper right window)
SP_SQ_DATA[7:6]	Chip ID for Channel 1
SP_SQ_DATA[9:8]	Port ID for Channel 2 (Lower left window)
SP_SQ_DATA[11:10]	Chip ID for Channel 2
SP_SQ_DATA[13:12]	Port ID for Channel 3 (Lower right window)
SP_SQ_DATA[15:14]	Chip ID for Channel 3
SP_SQ_DATA[19:16]	Channel 0 ~ 3 disable bit. Bit 16 set to 1, Channel 0 is disabled. Bit 17 set to 1, Channel 1 is disabled Bit 18 set to 1, Channel 2 is disabled Bit 19 set to 1, Channel 3 is disabled
SP_SQ_DATA[22:20]	Picture Type, as shown in Figure ??.
SP_SQ_DATA[23]	Strobe field type for field mode picture type. <b>1</b> Odd field <b>0</b> Even field

Address	[7]	[6]	[5]	[4]	[3]	[2]	[1]	[0]
0x29D								SP_SQ_ADDR
0x29E								SP_SQ_SIZE

**SP\_SQ\_ADDR** The switch queue entry address to perform the switch queue read / write command. This address is automatically incremented after the command is performed

**SP\_SQ\_SIZE** The switch queue size.  
 1 - 15: 1-15  
 16: 0

Address	[7]	[6]	[5]	[4]	[3]	[2]	[1]	[0]
0x2A0	SP_CH_EN_0	SP_FREEZE_0	SP_FUNC_MD_0	SP_ANA_0	0	SP_BLNK_0	SP_MIR_V_0	SP_MIR_H_0
0x2A1	SP_CH_EN_1	SP_FREEZE_1	SP_FUNC_MD_1	SP_ANA_1	0	SP_BLNK_1	SP_MIR_V_1	SP_MIR_H_1
0x2A2	SP_CH_EN_2	SP_FREEZE_2	SP_FUNC_MD_2	SP_ANA_2	0	SP_BLNK_2	SP_MIR_V_2	SP_MIR_H_2
0x2A3	SP_CH_EN_3	SP_FREEZE_3	SP_FUNC_MD_3	SP_ANA_3	0	SP_BLNK_3	SP_MIR_V_3	SP_MIR_H_3

**SP\_CH\_EN** Channel Enable Control for each of channel 0 through 3  
 1 Enable channel  
 0 Disable channel

**SP\_FREEZE** 1 Freeze the video  
 0 Disable freeze

**SP\_FUNC\_MD** When the SPOT Path is not in Switch mode, this bit specifies the SPOT mode of  
 1 Strobe Mode  
 0 Live Mode

**SP\_ANA** Specify the analog input selection of each of the channel.  
 0 VINA  
 1 VINB

**SP\_BLNK** Force the channel to display blank color  
 1 Blank Color  
 0 Normal video

**SP\_MIR\_V** Control to mirror the image vertically for each channel  
 0 Do not mirror vertically  
 1 Mirror vertically

**SP\_MIR\_H** Control to mirror the image horizontally for each channel  
 0 Do not mirror horizontally  
 1 Mirror horizontally

Address	[7]	[6]	[5]	[4]	[3]	[2]	[1]	[0]
0x2A4	0	0	0	0	SP_STROBE_3	SP_STROBE_2	SP_STROBE_1	SP_STROBE_0

**SP\_STROBE** Strobe command for each channel. Once set to 1, the corresponding channel will capture one field/frame and then clear this bit.

Address	[7]	[6]	[5]	[4]	[3]	[2]	[1]	[0]
0x2A5	0	SP_STRB_FLD	SP_CH_CYCLE		SP_SM_EN	SP_PIC_TYPE		

- SP\_STRB\_FLD** In non-switch mode, this bit controls which field to capture in field mode ( pic\_type 0, 2, 4, 6, 7)  
**0** Capture Even field  
**1** Capture Odd field
- SP\_CH\_CYCLE** In non-switch mode, this SP\_CH\_CYCLE controls how many channels to interleave when the pic\_type is 0, 1, 6, and 7.
- PIC\_TYPE 0, 1**  
**0** Capture and interleave channel 0, 1, 2, 3  
**1** Capture channel 0  
**2** Capture and interleave channel 0, 1  
**3** Capture and interleave channel 0, 1, 2
- PIC\_TYPE 6, 7**  
**1** Capture channel 0, 1  
**2** Capture and interleave channel 0, 1, 2, 3
- SP\_SM\_EN** **1** SPOT Path is in Switch Queue Mode  
**0** SPOT Path is in Live or Strobe Mode
- SP\_PIC\_TYPE** When SPOT Path is not in Switch Queue Mode, SP\_PIC\_TYPE specifies the pic\_type used in LIVE/Strobe mode

Address	[7]	[6]	[5]	[4]	[3]	[2]	[1]	[0]
0x2A6	SP_MOTN_ID_EN	SP_DIG_ID_EN	SP_ANA_ID_EN	SP_ANA_RIC_EN	SP_AUTO_ID_EN	SP_AUTO_RPT_EN	SP_DET_ID_EN	SP_USR_ID_EN

- SP\_MOTN\_ID\_EN** **1** Turn on motion information encoding  
**0** Do not turn on motion information encoding
- SP\_DIG\_ID\_EN** **1** Turn on the digital channel ID encoding  
**0** Turn off the digital channel ID encoding
- SP\_ANA\_ID\_EN** **1** Turn on the analog channel ID encoding  
**0** Turn off the analog channel ID encoding
- SP\_ANA\_RPT\_EN** **1** Turn on the analog auto channel ID repeat line  
**0** Turn off the analog auto channel ID repeat line
- SP\_AUTO\_ID\_EN** **1** Turn on the auto channel ID encoding  
**0** Turn off the auto channel ID encoding
- SP\_DET\_ID\_EN** **1** Turn on the detection ID encoding  
**0** Turn off the detection ID encoding
- SP\_USR\_ID\_EN** **1** Turn on the user information encoding  
**0** Turn off the user information encoding

Address	[7]	[6]	[5]	[4]	[3]	[2]	[1]	[0]
0x2A7	SP_ANA_CHID_H_OFST							

**SP\_ANA\_CHID\_H\_OFST**

The horizontal starting offset for Analog Channel ID

Address	[7]	[6]	[5]	[4]	[3]	[2]	[1]	[0]
0x2A8	SP_ANA_CHID_HIGH							
0x2A9	SP_ANA_CHID_LOW							

**SP\_ANA\_CHID\_HIGH** Pixel values bigger than this setting are interpreted as "1" for Analog Channel ID (default: 235)

**SP\_ANA\_CHID\_LOW** Pixel values smaller than this setting are interpreted as "0" for Analog Channel ID (default: 16)

Address	[7]	[6]	[5]	[4]	[3]	[2]	[1]	[0]
0x2AA	SP_CHID_V_OFSTO		0	SP_CHID_V_OFST				
0x2AB	SP_CHID_V_OFSTE		0	SP_ANA_CHID_BW				

**SP\_CHID\_V\_OFSTO** Control the vertical starting offset on top of SP\_CHID\_V\_OFST in odd field for Analog Channel ID

**SP\_CHID\_V\_OFSTE** Control the vertical starting offset on top of SP\_CHID\_V\_OFST in even field for Analog Channel ID

**SP\_CHID\_V\_OFST** Vertical starting offset for Analog Channel ID. The actual vertical line offset is  $SP\_CHID\_V\_OFST + SP\_CHID\_V\_OFSTO$  or  $SP\_CHID\_V\_OFST + SP\_CHID\_V\_OFSTE$

**SP\_ANA\_CHID\_BW** Control the pixel width of each bit for Analog Channel ID  
 0 1 pixel  
 : :  
 31 32 pixels (default)

Address	[7]	[6]	[5]	[4]	[3]	[2]	[1]	[0]
0x2AC	0	0	0	0	0	0	0	SP_GEN_EN

**SP\_GEN\_EN** Internal Test Function  
 Default 0

Address	[7]	[6]	[5]	[4]	[3]	[2]	[1]	[0]
0x2AD	SP_CHNUM1				SP_CHNUM0			
0x2AE	SP_CHNUM3				SP_CHNUM2			

**SP\_CHNUM** The Channel Number to display in non-switch mode  
 SP\_CHNUMx[3:2]: CHIP ID  
 SP\_CHNUMx[1:0]: PORT ID

Address	[7]	[6]	[5]	[4]	[3]	[2]	[1]	[0]
0x2B0	SP_USER_CHID[7:0]							
0x2B1	SP_USER_CHID[15:8]							
0x2B2	SP_USER_CHID[23:16]							
0x2B3	SP_USER_CHID[31:24]							
0x2B4	SP_USER_CHID[39:32]							
0x2B5	SP_USER_CHID[47:40]							
0x2B6	SP_USER_CHID[55:48]							
0x2B7	SP_USER_CHID[63:56]							

**SP\_USER\_CHID** Used to set the USER Channel ID for SPOT path.

Address	[7]	[6]	[5]	[4]	[3]	[2]	[1]	[0]
0x2B8	SP_HALF_LINE[7:0]							
0x2B9	SP_HALF_LINE[9:8]			SP_HS_P_OS				
0x2BA	SP_HS_WIDTH							

**SP\_HALF\_LINE** This defines in number of clock cycles from VS edge to the location of field change, in case it is change in middle of a line

**SP\_HS\_P\_OS** HSYNC starting location, in number of clock cycles

**SP\_HS\_WIDTH** HSYNC width, in number of clock cycles

Address	[7]	[6]	[5]	[4]	[3]	[2]	[1]	[0]
0x2BB	0	0	0	SP_TOP_VS_END				
0x2BC	0	0	0	SP_BOT_VS_END				
0x2BD	SP_T_VS_POS	0	0	SP_TOP_VS_OS				
0x2BE	SP_B_VS_POS	0	0	SP_BOT_VS_OS				

**SP\_TOP\_VS\_END** VSYNC trailing edge location of top field, in number of lines

**SP\_BOT\_VS\_END** VSYNC trailing edge location of bottom field, in number of lines

**SP\_TOP\_VS\_OS** VSYNC leading edge location of top field, in number of lines

**SP\_BOT\_VS\_OS** VSYNC leading edge location of bottom field, in number of lines

**SP\_T\_VS\_POS** Enable the top field vsync edge at the middle of a line.

**SP\_B\_VS\_POS** Enable the bottom field vsync edge at the middle of a line

Address	[7]	[6]	[5]	[4]	[3]	[2]	[1]	[0]
0x2BF			SP_HS_POL	SP_VS_POL	SP_FLD_POL	SP_VAV_POL	SP_HAV_POL	SP_656_ERRCHK

SP_HS_POL	Output HSYNC polarity control
SP_VS_POL	Output VSYNC polarity control
SP_FLD_POL	Output FIELD polarity control
SP_VAV_POL	Output VAV polarity control
SP_HAV_POL	Output HAV polarity control
SP_656_ERRCHK	Enable 656 SAV/EAV error check

Address	[7]	[6]	[5]	[4]	[3]	[2]	[1]	[0]
0x2C0								SP_16

SP\_16                      16 Window Display Mode

Address	[7]	[6]	[5]	[4]	[3]	[2]	[1]	[0]
0x2C1	SP_16_WINNUM1				SP_16_WINNUM0			
0x2C2	SP_16_WINNUM3				SP_16_WINNUM2			

SP\_16\_WINNUM            The window location of the 16 window configuration. The 16 windows are arranged as shown in the Figure 58.

Address	[7]	[6]	[5]	[4]	[3]	[2]	[1]	[0]
0x2C8	DP_HALF_LINE[7:0]							
0x2C9	DP_HALF_LINE[9:8]		DP_HS_P_OS					
0x2CA	DP_HS_WIDTH							

DP_HALF_LINE	This defines in number of clock cycles from VS edge to the location of field change, in case it is change in middle of a line
DP_HS_P_OS	HSYNC starting location, in number of clock cycles
DP_HS_WIDTH	HSYNC width, in number of clock cycles

Address	[7]	[6]	[5]	[4]	[3]	[2]	[1]	[0]
0x2CB								DP_TOP_VS_END
0x2CC								DP_BOT_VS_END
0x2CD	DP_T_VS_POS							DP_TOP_VS_OS
0x2CE	DP_B_VS_POS							DP_BOT_VS_OS

DP_TOP_VS_END	VSYNC trailing edge location of top field, in number of lines
DP_BOT_VS_END	VSYNC trailing edge location of bottom field, in number of lines
DP_TOP_VS_OS	VSYNC leading edge location of top field, in number of lines
DP_BOT_VS_OS	VSYNC leading edge location of bottom field, in number of lines
DP_T_VS_POS	Enable the top field vsync edge at the middle of a line.
DP_B_VS_POS	Enable the bottom field vsync edge at the middle of a line

Address	[7]	[6]	[5]	[4]	[3]	[2]	[1]	[0]
0x2CF			DP_HS_POL	DP_VS_POL	DP_FLD_POL	DP_VAV_POL	DP_HAV_POL	DP_656_ERRCHK

DP_HS_POL	Output HSYNC polarity control
DP_VS_POL	Output VSYNC polarity control
DP_FLD_POL	Output FIELD polarity control
DP_VAV_POL	Output VAV polarity control
DP_HAV_POL	Output HAV polarity control
DP_656_ERRCHK	Enable 656 SAV/EAV error check

Address	[7]	[6]	[5]	[4]	[3]	[2]	[1]	[0]
0x2D0	VE_FSCSEL		0	VE_FLD	VE_VS	0	1	VE_PAL_NTSC

VE_FSCSEL	Set the sub-carrier frequency for video encoder
0	3.57954545 MHz (default)
1	4.43361875 MHz
2	3.57561149 MHz
3	3.58205625 MHz
VE_FLD	Define the field detection type
0	Use field from input field signal (default)
1	Detect field from combination of HSENC and VSENC signals
VE_VS	Define the vertical sync (VSYNC) detection type
0	Use signal from input VSYNC
1	Detect VSYNC from combination of HSENC and FLDEN
VE_PAL_NTSC	Define the PAL or NTSC
0	NTSC
1	PAL

Address	[7]	[6]	[5]	[4]	[3]	[2]	[1]	[0]
0x2D1	VE_HSDEL[9:8]		VE_FLDPOL	VE_VSPOL	VE_HSPOL	VE_PED	VE_FDRST	VE_PHALT

<b>VE_FLDPOL</b>	<b>Control the field polarity</b> 0 Even field is high (default) 1 Odd field is high
<b>VE_VSPOL</b>	<b>Control the vertical sync polarity</b> 0 Active low (default) 1 Active high
<b>VE_HSPOL</b>	<b>Control the horizontal sync polarity</b> 0 Active low (default) 1 Active high
<b>VE_PED</b>	<b>Set 7.5 IRE for pedestal level</b> 0 IRE for pedestal level 1 7.5 IRE for pedestal level (default)
<b>VE_FDRST</b>	<b>Reset the phase alternation every 8 field</b> 0 No reset mode (default) 1 Reset the phase alternation every 8 field
<b>VE_PHALT</b>	<b>Set the phase alternation</b> 0 Disable phase alternation for line-by-line (default) 1 Enable phase alternation for line-by-line

Address	[7]	[6]	[5]	[4]	[3]	[2]	[1]	[0]
0x2D1	VE_HSDEL[9:8]		VE_FLDPOL	VE_VSPOL	VE_HSPOL	VE_PED	VE_FDRST	VE_PHALT
0x2D2	VE_HSDEL[7:0]							
0x2D3	VE_VSOFF		VE_VSDEL					

<b>VE_HSDEL</b>	<b>Control the pixel delay of horizontal sync from active video by <math>\frac{1}{2}</math> pixels/Step</b> 0 No delay : 256 64 pixels delay (default) : 1023 255 pixels delay
<b>VE_VSDEL</b>	<b>Control the line delay of vertical sync from active video by 1 line/step</b> 0 No delay : 32 32 lines delay (default) : 63 63 lines delay
<b>VE_VSOFF</b>	<b>Compensate the field offset for the first active video line</b> 0 Apply same VE_VSDEL for odd and even field (default) 1 Apply (VE_VSDEL+1) for odd and VE_VSDEL for even field 2 Apply VE_VSDEL for odd and (VE_VSDEL + 1) for even field 3 Apply VE_VSDEL for odd and (VE_VSDEL+2) for even field



Address	[7]	[6]	[5]	[4]	[3]	[2]	[1]	[0]
0x2D4				VE_ACTIVE_VDEL				
0x2D5	VE_ACTIVE_HDEL							

**VE\_ACTIVE\_VDEL** Control the line delay of active video by 1 line/step

0 -12 lines delay  
:  
12 0 line delay (default)  
:  
25 13 lines delay

**VE\_ACTIVE\_HDEL** Control the pixel delay of active video by 1 pixel/step

0 -32 pixels delay  
:  
32 0 pixel delay  
:  
63 31 pixels delay

Address	[7]	[6]	[5]	[4]	[3]	[2]	[1]	[0]
0x2D6	0	0	0		0		VE_ACTIVE_MD	VE_CCIR_STD

**VE\_ACTIVE\_MD** 0 Select the active delay mode for digital BT. 656 output control the active delay for both analog encoder and digital output (default)  
1 Control the active delay for only analog encoder

**VE\_T\_656\_STD** Select the ITU-R BT. 656 standard format for 60 Hz system  
0 240 lines for odd and even field  
1 244 lines for odd and 243 lines for even field (Standard)

Address	[7]	[6]	[5]	[4]	[3]	[2]	[1]	[0]
0x2D7	0	VE_OSD_SEL0	VE_SEL0		VE_CBW0		VE_YBW0	
0x2D8	0	VE_OSD_SEL1	VE_SEL1		VE_CBW1		VE_YBW1	

**VE\_OSD\_SEL** Select video encoder output with OSD  
1 Turn on OSD  
0 Turn off OSD

**VE\_SEL** Select the source of the video encoder  
0 Select display CVBS output  
1 Select SPOT CVBS output  
2 Select RECORD CVBS output  
3 Reserved

**VE\_CBW** Control the chrominance bandwidth of video encoder  
0 0.8 MHz  
1 1.15 MHz  
2 1.35 MHz (default)  
3 1.35 MHz

**VE\_YBW** Control the luminance bandwidth of video encoder  
0 Narrow bandwidth  
1 Narrower bandwidth  
2 Wide bandwidth (default)  
3 Middle bandwidth

Address	[7]	[6]	[5]	[4]	[3]	[2]	[1]	[0]
0x2D9		VE_CBGEN1	VE_CKILL1			VE_CBGEN0	VE_CKILL0	

**VE\_CBGEN** Enable the test pattern output  
**0** Normal operation  
**1** Internal color bar with 100% amplitude and 100% saturation

**VE\_CKILL** Enable the color kill function  
**0** Normal operation (default)  
**1** Color is killed

Address	[7]	[6]	[5]	[4]	[3]	[2]	[1]	[0]
0x2DF	AUX_DDR_DATA							

**AUX\_DDR\_DATA** The data register used to read/write the internal 64 bytes FIFO used to burst to/from the DDR

Address	[7]	[6]	[5]	[4]	[3]	[2]	[1]	[0]
0x2E0	AUX_DDR_ADDR[7:0]							
0x2E1	AUX_DDR_ADDR[15:8]							
0x2E2	AUX_DDR_ADDR[23:16]							

**AUX\_DDR\_ADDR** The address registers used to burst read/write to/from DDR

Address	[7]	[6]	[5]	[4]	[3]	[2]	[1]	[0]	
0x2E3	AUX_DDR_LENGTH[7:0]								
0x2E4	AUX_WAIT_POL	AUX_DDR_LENGTH[10:8]			AUX_FIFO_EMPTY*	AUX_FIFO_FULL*	AUX_DDR_RD	AUX_DDR_WR	

- AUX\_DDR\_LENGTH** Specify the length of the CPU burst read/write to/from DDR. The Maximum length is 1204 bytes
- AUX\_WAIT\_POL** Reverse the polarity of the AUX WAIT signal
- AUX\_FIFO\_EMPTY** The internal 64 bytes FIFO emptiness status flag  
**1** The 64 bytes internal FIFO is empty and available for writing data to burst to DDR  
**0** The 64 bytes internal FIFO is not empty, meaning the previous move from FIFO to DDR is not completed yet. The CPU should wait until this bit is set before writing a new 64 bytes.
- AUX\_FIFO\_FULL** The internal 64 bytes FIFO has data available for CPU to read  
This bit allows the CPU to poll after a AUX\_DDR\_RD command is issued, or after every 64 bytes of data are read. With this bit set, the CPU is safe to read up to 64 bytes, or up to the last burst length derived from the AUX\_DDR\_LENGTH  
**1** The 64 bytes internal FIFO has some data Available for CPU to read  
**0** The 64 bytes internal FIFO does not have data for CPU to read yet
- AUX\_DDR\_WR** The AUX DDR Write Command. This bit is self-cleared
- AUX\_DDR\_RD** The AUX DDR Read Command. This bit is self-cleared.

Address	[7]	[6]	[5]	[4]	[3]	[2]	[1]	[0]
0x2E5		DDR_RD_CLK_SEL			DDR_DQS_RD_DLY		DDR_RD_TO_WR_NOP	

- DDR\_RD\_CLK\_SEL** Select the DQS or ~DQS as read clock to latch the DQ
- DDR\_DQS\_RD\_DLY** Select the DQS valid read data cycle delay number
- DDR\_RD\_TO\_WR\_NOP** DDR read to write adds additional nop cycles. Default 0

Address	[7]	[6]	[5]	[4]	[3]	[2]	[1]	[0]
0x2E6								DDR_DQS_SEL0
0x2E7								DDR_DQS_SEL1
0x2E8		OSG_DDR_TIMER						DDR_CLK90_SEL

**DDR\_DQS\_SEL0** Select DDR\_DQS\_SEL/32 clock phase delay

**DDR\_DQS\_SEL1** Select DDR\_DQS\_SEL/32 clock phase delay

**DDR\_CLK90\_SEL** Select the phase of 90 degree CLK generated from DLL.  
The phase is DDR\_CLK90\_SEL/32

**OSG\_DDR\_TIMER** Timer to slow down the OSG write to avoid excessive peak bandwidth

Address	[7]	[6]	[5]	[4]	[3]	[2]	[1]	[0]
0x2E9	DDR_DLL_TEST_SEL		DDR_DLL_DEBUG_SEL					DDR_DLL_TAP_S

**DDR\_DLL\_DEBUG\_SEL** Debug select to the DLL Debug Output

**DDR\_DLL\_TEST\_SEL** Select the DLL test output signal

**DDR\_DLL\_TAP\_S** Select the DLL TAPS

Address	[7]	[6]	[5]	[4]	[3]	[2]	[1]	[0]
0x2EA	DDR_T_RC				DDR_T_RAS			
0x2EB	DDR_T_RFC							DDR_T_RP
0x2EC		DDR_T_RCD						DDR_T_WR

**DDR\_T\_RC** DDR t\_rc timing

**DDR\_T\_RAS** DDR t\_ras timing

**DDR\_T\_RFC** DDR t\_rfc timing

**DDR\_T\_RP** DDR t\_rp timing

**DDR\_T\_RCD** DDR t\_rcd timing

**DDR\_T\_WR** DDR t\_wr timing

Address	[7]	[6]	[5]	[4]	[3]	[2]	[1]	[0]
0x2ED		DDR_REFRESH			DDR_INIT_BYPASS		DDR_B_LENGTH	

**DDR\_REFRESH** DDR refresh timing control

**DDR\_INIT\_BYPASS** DDR initialization bypass (for simulation purpose only)

**DDR\_B\_LENGTH** DDR burst length

Address	[7]	[6]	[5]	[4]	[3]	[2]	[1]	[0]
0x2EE			DDR_CAS_LAT		DDR_SAMSUNG	0		DDR_SIZE

DDR\_CAS\_LAT                      DDR CAS Latency

DDR\_SAMSUNG                    Internal test mode

DDR\_SIZE

Address	[7]	[6]	[5]	[4]	[3]	[2]	[1]	[0]
0x2EF	DDR_WTR	DDR_B_TYPE	DDR_DV_ST	DDR_EN_DLL				

DDR\_WTR                            1      DDR Write to Read Turn Around cycle needed  
     0      No Write to Read Turn Around cycle needed

DDR\_B\_TYPE                        External DDR Burst Type, for initialization use

DDR\_DV\_ST                         Configure external DDR driving strength, for initialization use

DDR\_EN\_DLL                        Enable the DLL in the external DDR memory, for initialization use

Address	[7]	[6]	[5]	[4]	[3]	[2]	[1]	[0]
0x2F0	SOFT_RSTN	DLL_RST						

SOFT\_RSTN                         Software resetn signal for the whole chip. This bit does not reset the configuration registers.

0      Reset  
 1      Release Reset

DLL\_RST                            1      Reset DLLs  
     0      Release Reset DLLs

Address	[7]	[6]	[5]	[4]	[3]	[2]	[1]	[0]
0x2F1								CHIP_ID

CHIP\_ID                             Set the chip ID in cascade mode.

Address	[7]	[6]	[5]	[4]	[3]	[2]	[1]	[0]
0x2F5		SP_CC_CLK_SEL		RP_CC_CLK_SEL	0	0	0	0

SP\_CC\_CLK\_SEL                    [1]    Reverse the SPOT output sampling across clock domain from SCLK to CLKOS  
     [0]    Reverse the SPOT input sampling across clock domain from CLKIS to SCLK

RP\_CC\_CLK\_SEL                    [1]    Reverse the RECORD output sampling across clock domain from RCLK to CLKOY  
     [0]    Reverse the RECORD input sampling across clock domain from CLKIY to RCLK

Address	[7]	[6]	[5]	[4]	[3]	[2]	[1]	[0]
0x2F8	DP_CLK_CSCD_SEL		DP_CLK_CSCD_PD	CLKOX_SEL				

**DP\_CLK\_CSCD\_SEL** Select the clock source of the internal Display Cascade module clock

- 0 54 MHz
- 1 27 MHz
- 2 108 MHz
- 3 PPLL clock output

**DP\_CLK\_CSCD\_PD** Power down the display cascade clock

**CLKOX\_SEL** Select the source of the display output CLKOX pin

- 0 From cascade clock as determined by DP\_CLK\_CSCD\_SEL
- 1 From 27 MHz Clock Source

Address	[7]	[6]	[5]	[4]	[3]	[2]	[1]	[0]
0x2FB	CLKOY1_POL	CLKOY0_POL	CLKOS_POL	CLKOX_POL				

**CLKOY1\_POL** Reverse the clock polarity of output CLKOY1 pin

**CLKOY0\_POL** Reverse the clock polarity of output CLKOY0 pin

**CLKOS\_POL** Reverse the clock polarity of the CLKOS pin

**CLKOX\_POL** Reverse the clock polarity of the CLKOX pin

Address	[7]	[6]	[5]	[4]	[3]	[2]	[1]	[0]
0x2FC				CLKIX_POL	CLKPB_POL			

**CLKIX\_POL** Reverse the CLKIX polarity

**CLKPB\_POL** Reverse the CLKPB polarity

Address	[7]	[6]	[5]	[4]	[3]	[2]	[1]	[0]
0x2FD	CLKOS_DLY				CLKOX_DLY			

**CLKOS\_DLY** Select the delay of CLKOS

**CLKOX\_DLY** Select the delay of CLKOX

Address	[7]	[6]	[5]	[4]	[3]	[2]	[1]	[0]
0x2FE	CLKOY1_DLY				CLKOY0_DLY			

**CLKOY1\_DLY** Select the delay of CLKOY1

**CLKOY0\_DLY** Select the delay of CLKOY0

**Page 3: 0x300 ~ 0x3FE**

Address	[7]	[6]	[5]	[4]	[3]	[2]	[1]	[0]
0x301	0	BP_SCL_2S	BP_SCL_2Y	BP_SCL_2X	0	BP_SCL_1S	BP_SCL_1Y	BP_SCL_1X
0x302	0	BP_SCL_4S	BP_SCL_4Y	BP_SCL_4X	0	BP_SCL_3S	BP_SCL_3Y	BP_SCL_3X

BP_SCL_nX	Bypass the down scaler of display path for port n
1	Bypass
0	Do not bypass
BP_SCL_nY	Bypass the down scaler of record path for port n
1	Bypass
0	Do not bypass
BP_SCL_nS	Bypass the down scaler of SPOT path for port n
1	Bypass
0	Do not bypass

Address	[7]	[6]	[5]	[4]	[3]	[2]	[1]	[0]
0x303	0	1	PTRN_LIM_656	PTRN_SMALL	PTRN_CHIP_ID		PTRN_PAL	PTRN_EN

PTRN_LIM_656	Limit the pixel value generated by the internal pattern generator after the video decoder.
1	Limit Y to 235 maximum, 16 minimum
0	Do not limit
PTRN_SMALL	Internal pattern generator generates small frame. For simulation only
PTRN_CHIP_ID	Specify the chip ID of this chip
PTRN_PAL	1 Internal pattern generator generates PAL pattern 0 Internal pattern generator generates NTSC pattern
PTRN_EN	Enable Internal pattern generator to replace the video stream from video decoder
1	Enable the pattern generator
0	Use the video decoder input

Address	[7]	[6]	[5]	[4]	[3]	[2]	[1]	[0]
0x304	0	0	0	0	PTRN_VIDEO_LOSS			

PTRN_VIDEO_LOSS	Generate the video loss signal from the internal pattern generator
1	Video Loss
0	Video detected

Address	[7]	[6]	[5]	[4]	[3]	[2]	[1]	[0]
0x305	0	BP_NR_2S	BP_NR_2Y	BP_NR_2X	0	BP_NR_1S	BP_NR_1Y	BP_NR_1X
0x306	0	BP_NR_4S	BP_NR_4Y	BP_NR_4X	0	BP_NR_3S	BP_NR_3Y	BP_NR_3X

**BP\_NR\_nX** Bypass the noise reduction of display path for port n  
**1** Bypass  
**0** Do not bypass

**BP\_NR\_nY** Bypass the noise reduction of record path for port n  
**1** Bypass  
**0** Do not bypass

**BP\_NR\_nS** Bypass the noise reduction of SPOT path for port n  
**1** Bypass  
**0** Do not bypass

Address	[7]	[6]	[5]	[4]	[3]	[2]	[1]	[0]
0x340	VDLOSS_TH1				VDLOSS_TH0			
0x341	VDLOSS_TH3				VDLOSS_TH2			

**VDLOSS\_THn** Adjust the video loss signal presented to the backend modules from video decoder 0, 1, 2, and 3.  
**0** The backend video loss signal is the same as the video decoder video loss signal.  
**1 - 14** The backend video loss signal is asserted only when video decoder video loss signal is asserted for more than **VDLOSS\_THx** fields.  
**15** The backend video loss signal is never asserted regardless of the Video decoder video loss signal.

Address	[7]	[6]	[5]	[4]	[3]	[2]	[1]	[0]
0x350	NR2_SML_THD	NR2_FR2	NR2_FR1	NR2_FR0	NR1_SML_THD	NR1_FR2	NR1_FR1	NR1_FR0
0x351	NR4_SML_THD	NR4_FR2	NR4_FR1	NR4_FR0	NR3_SML_THD	NR3_FR2	NR3_FR1	NR3_FR0

**NRn\_FR0** Force port n noise reduction to level 0 - Disable noise reduction

**NRn\_FR1** Force port n noise reduction to level 1 - weak

**NRn\_FR2** Force port n noise reduction to level 2 - strong

**NRn\_SML\_THD** Default 0

Address	[7]	[6]	[5]	[4]	[3]	[2]	[1]	[0]
0x352	0	0	0	0	NR4_RST_DET	NR3_RST_DET	NR2_RST_DET	NR1_RST_DET

**NRn\_RST\_DET** Reset the noise reduction detection for port n



Address	[7]	[6]	[5]	[4]	[3]	[2]	[1]	[0]
0x356	NR_DET_OUT_THD							NR_DET_REF_VAR

NR\_DET\_OUT\_THD      Default 6

NR\_DET\_REF\_VAR      Default 1

Address	[7]	[6]	[5]	[4]	[3]	[2]	[1]	[0]
0x357	NR_DET_NOISE_1L							
0x358	NR_DET_NOISE_1H							
0x359	NR_DET_NOISE_2L							
0x35A	NR_DET_NOISE_2H							
0x35B	NR_DET_NOISE_CL							
0x35C	NR_DET_NOISE_CH							
0x35D	NR_DET_SKIP_L							
0x35E	NR_DET_SKIP_H							

NR\_DET\_NOISE\_1L      Lower bound of pixel distance for noise level 1  
Default: 3

NR\_DET\_NOISE\_1H      Higher bound of pixel distance for noise level 1  
Default: 10

NR\_DET\_NOISE\_2L      Lower bound of pixel distance for noise level 2  
Default: 5

NR\_DET\_NOISE\_2H      Higher bound of pixel distance for noise level 2  
Default: 15

NR\_DET\_NOISE\_CL      Lower bound of pixel distance for chroma noise level  
Default: 4

NR\_DET\_NOISE\_CH      Higher bound of pixel distance for chroma noise level  
Default: 10

NR\_DET\_SKIP\_L      Pixels with value below this threshold will not be processed  
Default: 25

NR\_DET\_SKIP\_H      Pixels with value above this threshold will not be processed  
Default: 240

Address	[7]	[6]	[5]	[4]	[3]	[2]	[1]	[0]
0x35F	NRDET4_LVL*		NRDET3_LVL*		NRDET2_LVL*		NRDET1_LVL*	

\*Read only

NRDEtn\_LVL      Detected noise level for channel n  
0      Disable noise  
1      Weak noise reduction  
2      Strong noise reduction

Address	[7]	[6]	[5]	[4]	[3]	[2]	[1]	[0]
---------	-----	-----	-----	-----	-----	-----	-----	-----

0x380									HSCL_DISP_TARG_1
0x390									HSCL_DISP_TARG_2
0x3A0									HSCL_DISP_TARG_3
0x3B0									HSCL_DISP_TARG_4

**HSCL\_DISP\_TARG\_n** The display down scaler target horizontal size for port n. The unit is in multiple of 16 pixels

Address	[7]	[6]	[5]	[4]	[3]	[2]	[1]	[0]	
0x381									VSCL_DISP_TARG_1
0x391									VSCL_DISP_TARG_2
0x3A1									VSCL_DISP_TARG_3
0x3B1									VSCL_DISP_TARG_4

**VSCL\_DISP\_TARG\_n** The display down scaler target vertical size for port n. The unit is in multiple of 8 lines

Address	[7]	[6]	[5]	[4]	[3]	[2]	[1]	[0]	
0x382									HSCL_REC_TARG_1
0x392									HSCL_REC_TARG_2
0x3A2									HSCL_REC_TARG_3
0x3B2									HSCL_REC_TARG_4

**HSCL\_REC\_TARG\_n** The record down scaler target horizontal size for port n. The unit is in multiple of 16 pixels

Address	[7]	[6]	[5]	[4]	[3]	[2]	[1]	[0]	
0x383									VSCL_REC_TARG_1
0x393									VSCL_REC_TARG_2
0x3A3									VSCL_REC_TARG_3
0x3B3									VSCL_REC_TARG_4

**VSCL\_REC\_TARG\_n** The record down scaler target vertical size for port n. The unit is in multiple of 8 lines

Address	[7]	[6]	[5]	[4]	[3]	[2]	[1]	[0]	
0x384									HSCL_SPOT_TARG_1
0x394									HSCL_SPOT_TARG_2
0x3A4									HSCL_SPOT_TARG_3
0x3B4									HSCL_SPOT_TARG_4

**HSCL\_SPOT\_TARG\_n** The SPOT down scaler target horizontal size for port n. The unit is in multiple of 16 pixels

Address	[7]	[6]	[5]	[4]	[3]	[2]	[1]	[0]
0x385								VSCL_SPOT_TARG_1
0x395								VSCL_SPOT_TARG_2
0x3A5								VSCL_SPOT_TARG_3
0x3B5								VSCL_SPOT_TARG_4

**VSCL\_SPOT\_TARG\_n** The SPOT down scaler target vertical size for port n. The unit is in multiple of 8 lines

Address	[7]	[6]	[5]	[4]	[3]	[2]	[1]	[0]
0x387								HSCL_DISP_SRC_1
0x397								HSCL_DISP_SRC_2
0x3A7								HSCL_DISP_SRC_3
0x3B7								HSCL_DISP_SRC_4

**HSCL\_DISP\_SRC\_n** The display down scaler source horizontal size for port n. The unit is in multiple of 16 pixels

Address	[7]	[6]	[5]	[4]	[3]	[2]	[1]	[0]
0x388								VSCL_DISP_SRC_1
0x398								VSCL_DISP_SRC_2
0x3A8								VSCL_DISP_SRC_3
0x3B8								VSCL_DISP_SRC_4

**VSCL\_DISP\_SRC\_n** The display down scaler source vertical size for port n. The unit is in multiple of 8 lines

Address	[7]	[6]	[5]	[4]	[3]	[2]	[1]	[0]
0x389								HSCL_REC_SRC_1
0x399								HSCL_REC_SRC_2
0x3A9								HSCL_REC_SRC_3
0x3B9								HSCL_REC_SRC_4

**HSCL\_REC\_SRC\_n** The record down scaler source horizontal size for port n. The unit is in multiple of 16 pixels

Address	[7]	[6]	[5]	[4]	[3]	[2]	[1]	[0]
0x38A								VSCL_REC_SRC_1
0x39A								VSCL_REC_SRC_2
0x3AA								VSCL_REC_SRC_3
0x3BA								VSCL_REC_SRC_4

**VSCL\_REC\_SRC\_n** The record down scaler source vertical size for port n. The unit is in multiple of 8 lines

Address	[7]	[6]	[5]	[4]	[3]	[2]	[1]	[0]
0x38B								HSCL_SPOT_SRC_1
0x39B								HSCL_SPOT_SRC_2
0x3AB								HSCL_SPOT_SRC_3
0x3BB								HSCL_SPOT_SRC_4

**HSCL\_SPOT\_SRC\_n** The SPOT down scaler source horizontal size for port n. The unit is in multiple of 16 pixels

Address	[7]	[6]	[5]	[4]	[3]	[2]	[1]	[0]
0x38C								VSCL_SPOT_SRC_1
0x39C								VSCL_SPOT_SRC_2
0x3AC								VSCL_SPOT_SRC_3
0x3BC								VSCL_SPOT_SRC_4

**VSCL\_SPOT\_SRC\_n** The SPOT down scaler source vertical size for port n. The unit is in multiple of 8 lines

Address	[7]	[6]	[5]	[4]	[3]	[2]	[1]	[0]
0x386						FLDPOL_1S	FLDPOL_1Y	FLDPOL_1X
0x396						FLDPOL_2S	FLDPOL_2Y	FLDPOL_2X
0x3A6						FLDPOL_3S	FLDPOL_3Y	FLDPOL_3X
0x3B6						FLDPOL_4S	FLDPOL_4Y	FLDPOL_4X

**FLDPOL\_nX** The display downscaler field polarity control for port n

**FLDPOL\_nY** The record downscaler field polarity control for port n

**FLDPOL\_nS** The SPOT downscaler field polarity control for port n

## Page 4: 0x400 ~ 0x4FE

Address	[7]	[6]	[5]	[4]	[3]	[2]	[1]	[0]
0x480							VGA_RD_DIS	VGA_RST

**VGA\_RST** Software Reset for VGA / De-Interlacer / Brightness Control / RGB control, timing generation modules. When this bit is set, the VGA sync is lost.

**VGA\_RD\_DIS** Software Disable of the video buffer read side of the VGA path. When this bit is set, the VGA output become blanks, and the VGA sync is not lost. This bit can be set when the display configuration change is performed.

Address	[7]	[6]	[5]	[4]	[3]	[2]	[1]	[0]
0x488	GAMMA_ADDR[7:0]							
0x489							GAMMA_ADDR[9:8]	
0x48A	GAMMA_WDATA[7:0]							
0x48B							GAMMA_WDATA[9:8]	
0x48C	GAMMA_RDATA[7:0]*							
0x48D							GAMMA_RDATA[9:8]*	
0x48E	GAMMA_RD_START							

**GAMMA\_ADDR**      Gamma table address

**GAMMA\_WDATA**      Gamma table write data. The indirect write starts after writing 0x48B

**GAMMA\_RDATA**      Gamma table read data (Read Only)

**GAMMA\_RD\_START**      Command to start a read by writing register 0x48E. Data written to 0x48E does not matter.

Address	[7]	[6]	[5]	[4]	[3]	[2]	[1]	[0]	
0x490	M2DI_LOW_ANGLE_CNTL								M2DI_USE_BOB

**M2DI\_LOW\_ANGLE\_CNTL**      Disable a specific criterion to disqualify low angle. Default 0

**M2DI\_USE\_BOB**      Use BOB instead of low angle. Default 0

Address	[7]	[6]	[5]	[4]	[3]	[2]	[1]	[0]
0x491	0	0	0	1	1	0	0	1
0x492	0	0	1	1	1	1	0	0
0x493	1	1	0	0	1	0	0	0
0x494	1	0	1	1	0	1	0	0
0x495	0	0	0	0	0	0	0	1
0x496	0	0	0	0	1	0	1	0
0x497	0	0	0	0	1	0	1	0

Reserved

Address	[7]	[6]	[5]	[4]	[3]	[2]	[1]	[0]
0x498	M2DI_FRM_WIDTH[7:0]							
0x499	M2DI_FRM_PITCH[7:0]							
0x49A	M2DI_FRM_PITCH[10:8]				M2DI_FRM_WIDTH[10:8]			
0x49B	M2DI_FRM_HEIGHT[7:0]							
0x49C	M2DI_FRM_HEIGHT[9:8]							

**M2DI\_FRM\_WIDTH**      The frame width of the incoming video in pixels

**M2DI\_FRM\_PITCH**      The frame width allocated in the memory including the unused portion at the end of each line

**M2DI\_FRM\_HEIGHT**      The frame height of the incoming video in lines

Address	[7]	[6]	[5]	[4]	[3]	[2]	[1]	[0]
0x4A0	UPS_BG_COLR							

UPS\_BG\_COLR

Background color used for UPS

Y = {UPS\_BG\_COLR[7:6], 6'b0}

Cb = {UPS\_BG\_COLR[5:3], 5'b0}

Cr = {UPS\_BG\_COLR[2:0], 5'b0}

Address	[7]	[6]	[5]	[4]	[3]	[2]	[1]	[0]
0x4A1	UPS_HST							
0x4A2	UPS_VST							
0x4A3	UPS_HACTIVE_O[7:0]							
0x4A4	UPS_VACTIVE_O[7:0]							
0x4A5	UPS_VACTIVE_O[10:8]				UPS_HACTIVE_O[10:8]			

UPS\_HST

Specify the video starting horizontal location in the output video frame

UPS\_VST

Specify the video starting vertical location in the output video frame

UPS\_HACTIVE\_O

Specify the video width shown in the output video frame after scaling

UPS\_VACTIVE\_O

Specify the video height shown in the output video frame after scaling

Address	[7]	[6]	[5]	[4]	[3]	[2]	[1]	[0]
0x4A8	UPS_HACTIVE_IN[7:0]							
0x4A9	UPS_VACTIVE_IN[7:0]							
0x4AA	UPS_VACTIVE_IN[10:8]				UPS_HACTIVE_IN[10:8]			

UPS\_HACTIVE\_IN

Specify the upscaler input horizontal video width

UPS\_VACTIVE\_IN

Specify the upscaler input vertical video height

Address	[7]	[6]	[5]	[4]	[3]	[2]	[1]	[0]
0x4AB	UPS_HSCALE[7:0]							
0x4AC	UPS_HSCALE[12:0]							
0x4AD	UPS_VSCALE[7:0]							
0x4AE	UPS_VSCALE[10:8]							

UPS\_HSCALE

Horizontal scaling factor. 0x1000 represents scaling factor of 1

UPS\_VSCALE

Vertical scaling factor. 0x400 represents scaling factor of 1

Address	[7]	[6]	[5]	[4]	[3]	[2]	[1]	[0]
0x4AF	VGA_BLACKOUT							

VGA\_BLACKOUT

1 Black out the VGA output  
0 Normal display

Address	[7]	[6]	[5]	[4]	[3]	[2]	[1]	[0]
0x4B0	VGA_SHWIN			VGA_SHCOR				
0x4B1	VGA_OVERSHOOT				VGA_SHARP			

VGA_SHWIN[1]	Sharpening filter window size selection
0	2 pixels
1	4 pixels
VGA_SHWIN[0]	Sharpening filter min/max window size selection
0	2 pixels
1	4 pixels
VGA_SHCOR	Sharpening Coring Setting
VGA_OVERSHOOT	Sharpening overshoot setting
VGA_SHARP	Sharpening gain

Address	[7]	[6]	[5]	[4]	[3]	[2]	[1]	[0]
0x4B2	VGA_BLACK							
0x4B3	VGA_Y_GAIN							
0x4B4	VGA_Y_OFFSET							
0x4B5	VGA_CR_GAIN							
0x4B6	VGA_CB_GAIN							

VGA_BLACK	The black level used for contrast control. Any incoming pixel less than this value is assume to be black. The contrast control does not amplify the black pixels.
VGA_Y_GAIN	The contrast control. A setting of 64 represents gain of 1 (neutral)
VGA_Y_OFFSET	The brightness control. A value of 128 represents offset of 0 (neutral)
VGA_CR_GAIN	Cr gain control. A value of 64 represents gain of 1 (neutral)
VGA_CB_GAIN	Cb gain control. A value of 64 represents gain of 1 (neutral)

Address	[7]	[6]	[5]	[4]	[3]	[2]	[1]	[0]
0x4B7	VGA_BKLV	VGA_WHTLV	VGA_HUEADJ					
0x4B8	VGA_BWLST[7:0]							
0x4B9	VGA_BWLEND[7:0]							
0x4BA	VGA_BWLEND[11:8]				VGA_BWLST[11:8]			
0x4BB	VGA_BWFGAIN				VGA_BWHGAIN			
0x4BC	VGA_BTILT							
0x4BD	VGA_WTILT							
0x4BE	VGA_BLIMIT							
0x4BF	VGA_WLIMIT							

VGA_HUEADJ	HUE Control
VGA_WHTLV	0 235 as white 1 255 as white
VGA_BKLV	0 0 as black 1 16 as black
VGA_BWLST	The first line of the black / white detection window for BW stretch
VGA_BWLEND	The last line of the black / white detection window for BW stretch
VGA_BWHGAIN	Tap for pixel recursive filtering before black / white line minmax detection
VGA_BWFGAIN	Tap for field recursive filtering before black / white field minmax detection
VGA_BTILT	Black Tilt point for BW stretch
VGA_WTILT	White Tilt point for BW stretch
VGA_BLIMIT	The darkest pixel value after BW stretch
VGA_WLIMIT	The brightest pixel value after BW stretch



Address	[7]	[6]	[5]	[4]	[3]	[2]	[1]	[0]
0x4C8	VGA_R_GAIN							
0x4C9	VGA_R_OFFSET							
0x4CA	VGA_G_GAIN							
0x4CB	VGA_G_OFFSET							
0x4CC	VGA_B_GAIN							
0x4CD	VGA_B_OFFSET							

VGA_R_GAIN	Red color gain control. A setting of 64 represents gain of 1 (neutral)
VGA_R_OFFSET	Red color offset control. A setting of 128 represents offset of 0 (neutral)
VGA_G_GAIN	Green color gain control. A setting of 64 represents gain of 1 (neutral)
VGA_G_OFFSET	Green color offset control. A setting of 128 represents offset of 0 (neutral)
VGA_B_GAIN	Blue color gain control. A setting of 64 represents gain of 1 (neutral)
VGA_B_OFFSET	Blue color offset control. A setting of 128 represents offset of 0 (neutral)

Address	[7]	[6]	[5]	[4]	[3]	[2]	[1]	[0]
0x4D0	VGA_HTOTAL[7:0]							
0x4D1	VGA_VTOTAL[7:0]							
0x4D2	VGA_VTOTAL[10:8]				VGA_HTOTAL[10:8]			
0x4D3	VGA_HSTART[7:0]							
0x4D4	VGA_HACTIVE[7:0]							
0x4D5	VGA_HACTIVE[10:8]				VGA_HSTART[10:8]			
0x4D6	VGA_VSTART[7:0]							
0x4D7	VGA_VACTIVE[7:0]							
0x4D8	VGA_VACTIVE[10:8]				VGA_VSTART[10:8]			
0x4D9	VGA_TRACK_EN	VGA_AUTO_ADJ		VGA_LOCK_EN	VGA_TIM_WIN			

**VGA\_HTOTAL** VGA pixel size per line, including horizontal blanking. Note the following condition needs to be met.

$$\text{VGA\_HTOTAL} - \text{VGA\_HSTART} - \text{VGA\_HACTIVE} > 6$$

**VGA\_VTOTAL** VGA line size per frame, including the vertical blanking. Note the following condition needs to be met.

$$\text{VGA\_VTOTAL} - \text{VGA\_VSTART} - \text{VGA\_VACTIVE} > 2$$

**VGA\_HSTART** VGA active pixel starting location relative to the leading edge of HSYNC, in # of pixels.

$$\text{VGA\_HSTART} = \text{VGA\_HS\_WIDTH} + \text{H Back Porch} - 6$$

**VGA\_HACTIVE** VGA active pixel width per line, in # of pixels

**VGA\_VSTART** VGA active line starting location relative to the leading edge of VSYNC, in # of lines

$$\text{VGA\_VSTART} = \text{VGA\_VS\_WIDTH} + \text{V Back Porch}$$

**VGA\_VACTIVE** VGA active line height per frame, in # of lines

**VGA\_TRACK\_EN** Enable frame tracking.  
**0** Does not do frame tracking. Always use free running control  
**1** Enable frame tracking

**VGA\_AUTO\_ADJ** **0** Hardware does not adjust to do frame tracking  
**1** Hardware adjust the configuration to do frame tracking

**VGA\_LOCK\_EN** **0** Free running  
**1** Lock to incoming video timing

**VGA\_TIM\_WIN** In frame tracking, this parameter specifies the maximum number of lines inserted in the vertical blanking to track the incoming frame

Address	[7]	[6]	[5]	[4]	[3]	[2]	[1]	[0]
0x4DA							VGA_HS_POL	VGA_VS_POL
0x4DB	VGA_HS_WIDTH							
0x4DC	VGA_VS_WIDTH							

VGA\_VS\_POL            1     Negative (Low active)  
                               0     Positive (High active)

VGA\_HS\_POL            1     Negative (Low active)  
                               0     Positive (High active)

VGA\_HS\_WIDTH         VGA HSYNC width in # of pixels

VGA\_VS\_WIDTH         VGA VSYNC height in # of lines

Address	[7]	[6]	[5]	[4]	[3]	[2]	[1]	[0]
0x4E0						USE_GAMMAB	USE_GAMMAG	USE_GAMMAR
0x4E1	DITHER_BP	S_DM				S_BC		

USE\_GAMMAR            Enable red color gamma table

USE\_GAMMAG           Enable green color gamma table

USE\_GAMMAB           Enable blue color gamma table

S\_BC                    Output Pixel Width for each of R, G, B value  
                               0: 8:8:8 (default)  
                               1: 6:6:6  
                               2: 5:6:5  
                               3: 5:5:5  
                               4: 4:4:4  
                               5: 3:3:3  
                               6: 3:3:2

S\_DM                    Dithering mode configuration. This specifies the number of lower bits for dithering.

DITHER\_BP             Bypass dithering

Address	[7]	[6]	[5]	[4]	[3]	[2]	[1]	[0]
0x4E2	FP_PX_MODE	FP_DE_AH	FP_HS_AH	FP_VS_AH	FP_CK_AH			
0x4E3			FP_SEL_LG		FP_SIG_OFF	FP_CKTPS		

FP_PX_MODE	1	Set dual channel LVDS output
	0	Set single channel LVDS output
FP_DE_AH	1	Panel DE signal active high
	0	Panel DE signal active low
FP_HS_AH	1	Panel HS signal active high
	0	Panel HS signal active low
FP_VS_AH	1	Panel VS signal active high
	0	Panel VS signal active low
FP_CK_AH	Reverse the FPCLK polarity	
	1	Data is sampled at the falling edge
	0	Data is sampled at the rising edge
FP_SEL_LG	0	Select the LVDS mapping of the Samsung type
	1	Select the LVDS mapping of the LG type
	1	Reserved
	2	Reserved
FP_SIG_OFF	0	Do not turn off the panel
	1	Turn off the panel
FP_CKTPS	Reserved	

Address	[7]	[6]	[5]	[4]	[3]	[2]	[1]	[0]
0x4E4	FP_PWR_CLK_DV							
0x4E5	FP_CLK_PWDN	FP_CLKSEL			FP_MAN_PWR	FP_EDPMS	FP_PCR	

**FP\_PWR\_CLK\_DV** MSB of the internal 23 bit divide down counter. The 27 MHz clock is divided by this counter to serve as the clock for Power State Transition timer.

**FP\_CLK\_PWDN** 1 Force the internal panel clock to power down

**FP\_CLKSEL** Default 1

**FP\_MAN\_PWR** Show current power management state. These power states determine the states of FPPWC, FPBIAS, and FP Interfaces such as FPVS, FPDE, FPCLK and all data signals.

	FPPWC	FPBIAS	FP Interfaces
00: off	"0"	"0"	"0"
01: Standby	"1"	"0"	"0"
10: Suspend	"1"	"0"	"1" or "0"
11: On	"1"	"1"	"1" or "0"

The transition between power states does not occur right away. It takes place after the timer expiration defined in 0x4E6 ~ 0x4E8

**FP\_EDPMS** If FP\_MAN\_PWR is "0" and FP\_EDPMS is "1", it enables auto power sequencing.

VSYNC loss & HSYNC loss	Off
VSYNC loss & HSYNC active	Standby
VSYNC active & HSYNC loss	Suspend
VSYNC active & HSYNC active	On

**FP\_PCR** Force the power state to sequence to this state, and stay in this state

0	Off
1	Standby
2	Suspend
3	On

Address	[7]	[6]	[5]	[4]	[3]	[2]	[1]	[0]
0x4E6	FP_ITV12				FP_ITV01			
0x4E7	FP_ITV32				FP_ITV23			
0x4E8	FP_ITV21				FP_ITV10			
0x4E9	FP_PWM_CLK_SEL	FP_PWM						
0x4EB								FP_PWM_AL

FP_ITV01	Timer counts for On state to Suspend state transition
FP_ITV12	Timer counts for Suspend state to Standby state transition
FP_ITV23	Timer counts for Standby state to Power Off state
FP_ITV32	Timer counts for Power Off state to Standby state
FP_ITV10	Timer count for Suspend state to On State
FP_ITV21	Timer count for Standby state to Suspend state
FP_PWM_CLK_SEL	1 PWM clock set to 27 MHz 0 PWM clock set to 13.5 MHz
FP_PWM	Pulse width of PWM is FP_PWM + 1
FP_PWM_AL	PWM Output Polarity 1 Reverse PWM signal output polarity 0 Do not reverse PWM signal output polarity

Address	[7]	[6]	[5]	[4]	[3]	[2]	[1]	[0]
0x4F0		VGA_BYP_OSD	VGA_BYP_DI	VGA_DATA0	VGA_BYP_HUE	VGA_BYP_YUV	VGA_BYP_SHARP	VGA_BYP_BW
0x4F2	VGA_BWGEN_PTRN		VGA_BWGEN_EN					VGA_CGEN_EN

VGA_BYP_OSD	1	Bypass OSD for the VGA path
	0	Do not bypass OSD
VGA_BYP_DI	1	Bypass DI operation
	0	Does not bypass DI
VGA_DATA0	1	Blank out the whole screen
	0	Normal operation
VGA_BYP_HUE	1	Bypass Hue Control
	0	Does not bypass Hue Control
VGA_BYP_YUV	1	Bypass YUV contrast / gain control
	0	Does not bypass YUV contrast / gain control
VGA_BYP_SHARP	1	Bypass sharpness control
	0	Does not bypass sharpness control
VGA_BYP_BW	1	Bypass black / white stretch control
	0	Does not bypass black / white stretch control
VGA_BWGEN_PTRN	Test pattern for internal use	
	0	Black / White Pattern
	1	Color Pattern
	2	Color Bar
	3	Y Single line
	4	Y block
	5	BW pattern
	6/7	Black
VGA_BWGEN_EN	Pattern Generation Enable for Internal Test only	
VGA_CGEN_EN	Pattern Generation Enable for Internal use only	

Address	[7]	[6]	[5]	[4]	[3]	[2]	[1]	[0]
0x4F3	VGA_DEBUG_DATA[7:4]				VGA_DEBUG_DATA[3:0] * / VGA_DEBUG_SEL			

VGA_DEBUG_SEL	Write only. Set this to select the read back of register 0x4F0
VGA_DEBUG_DATA	The setting of VGA_DEBUG_SEL determines the read back of this register.
	1 BWYMIN
	2 BWYMAX
	3 BWFMIN
	4 BWFMAX
	Others Not valid

**Page 5: 0x500 ~ 0x51F**

Address	[7]	[6]	[5]	[4]	[3]	[2]	[1]	[0]
0x508	VDOX_BT1120_SEL	VDOX_FLD_POL	VDOX_1120_CROP	VDOX_HVS_MD	VDOX_DIG_OSD_BP			DISP_CVBS_EN

DISP_CVBS_EN	1	Enable Display CVBS Path
	0	Enable display digital output (either BT1120 or 8-bit cascade)
VDOX_DIG_OSD_BP	1	Bypass the digital display path OSD
	0	Enable the OSD on the display digital output
VDOX_HVS_MD	1	Output HAV/VAV signal at the HSYNC VSYNC port
	0	Output regular HSYNC/VSYNC signal
VDOX_1120_CROP	1	BT1120 mode crop window enabled
	0	BT1120 mode crop window disabled
VDOX_FLD_POL	1	Reverse the field polarity for display digital output
	0	Do not reverse the field polarity for display digital output
VDOX_BT1120_SEL	1	Select display digital output as the BT1120 output
	0	Select display digital output as the 8-bit Cascade output

Address	[7]	[6]	[5]	[4]	[3]	[2]	[1]	[0]
0x509	VDOX_BT1120_TOP_OS[7:0]							
0x50A	VDOX_BT1120_BOT_OS[7:0]							
0x50B	VDOX_BT1120_L_OS[7:0]							
0x50C	VDOX_BT1120_R_OS[7:0]							
0x50D				VDOX_BT1120_R_OS[8]				VDOX_BT1120_BOT_OS[8]

**VDOX\_BT1120\_TOP\_OS** Top offset defining the vertical starting location of active video in the BT1120 (1920x1080) frame

**VDOX\_BT1120\_BOT\_OS** Bottom offset defining the vertical ending location of active video in the BT1120 (1920x1080) frame

**VDOX\_BT1120\_L\_OS** Left offset defining the horizontal starting location of active video in the BT1120 (1920x1080) frame

**VDOXD\_BT1120\_R\_OS** Right offset defining the horizontal ending location of active video in the BT1120 (1920x1080) frame



Address	[7]	[6]	[5]	[4]	[3]	[2]	[1]	[0]
0x50F	VDOX_VAV_ODD_OFS							
0x510	VDOX_VAV_EVEN_OFS							

**VDOX\_VAV\_ODD\_OFS** The line number between the beginning of the ODD field and the beginning of VAV of display digital output (BT1120 or cascade)

**VDOX\_VAV\_EVEN\_OFS** The line number between the beginning of the EVEN field and the beginning of VAV of display digital output (BT1120 or cascade)

Address	[7]	[6]	[5]	[4]	[3]	[2]	[1]	[0]
0x511	VDOX_VS_POL	VDOX_HS_POL	VDOX_VS_ETP_EN	VDOX_VS_ELP_EN	VDOX_VS_OTP_EN	VDOX_VS_OLP_EN		

**VDOX\_VS\_POL** Select the VS polarity of display digital output.  
**1** Low active  
**0** High active

**VDOX\_HS\_POL** Select the HS polarity of display digital output  
**1** Low active  
**0** High active

**VDOX\_VS\_ETP\_EN** Enable the pixel offset of even field VS trailing edge relative to HS specified with VDOX\_VS\_POFS

**VDOX\_VS\_ELP\_EN** Enable the pixel offset of even field VS leading edge relative to HS specified with VDOX\_VS\_POFS

**VDOX\_VS\_OTP\_EN** Enable the pixel offset of odd field VS trailing edge relative to HS specified with VDOX\_VS\_POFS

**VDOX\_VS\_OLP\_EN** Enable the pixel offset of odd field VS leading edge relative to HS specified with VDOX\_VS\_POFS

Address	[7]	[6]	[5]	[4]	[3]	[2]	[1]	[0]
0x512	VDOX_VS_POFS[11:8]				VDOX_VSYNC_WIDTH			
0x513	VDOX_VS_POFS[7:0]							

**VDOX\_VS\_POFS** The pixel offset of VS edge relative to HS for the display digital output timing

**VDOX\_VSYNC\_WIDTH** The VSYNC width in unit of lines for the display digital output timing

Address	[7]	[6]	[5]	[4]	[3]	[2]	[1]	[0]
0x514	VDOX_VS_E_LOFS				VDOX_VS_O_LOFS			

**VDOX\_VS\_E\_LOFS** The even field line offset of the VS relative to the edge of field change for the display digital output timing

**VDOX\_VS\_O\_LOFS** The odd field line offset of the VS relative to the edge of field change for the display digital output timing

Address	[7]	[6]	[5]	[4]	[3]	[2]	[1]	[0]
---------	-----	-----	-----	-----	-----	-----	-----	-----

0x515							VDOX_HS_WIDTH[8]	0
0x516	VDOX_HS_WIDTH[7:0]							
0x517	0							

**VDOX\_HS\_WIDTH**      The HSYNC Width in number of pixels for the display digital output timing

Address	[7]	[6]	[5]	[4]	[3]	[2]	[1]	[0]
0x518	VDOX_HACTIVE[11:8]						VDOX_VACTIVE[9:8]	
0x519	VDOX_VACTIVE[7:0]							
0x51A	VDOX_HACTIVE[7:0]							

**VDOX\_HACTIVE**      The active pixels per line for the display digital output timing

**VDOX\_VACTIVE**      The active lines per field for the display digital output timing

Address	[7]	[6]	[5]	[4]	[3]	[2]	[1]	[0]
0x51B			VDOX_OVT[9:8]				VDOX_EVT[9:8]	
0x51C	VDOX_EVT[7:0]							
0x51D	VDOX_OVT[7:0]							

**VDOX\_EVT**      The total line number of even field including vertical blanking for the display digital output timing

**VDOX\_OVT**      The total line number of odd field including vertical blanking for the display digital output timing

Address	[7]	[6]	[5]	[4]	[3]	[2]	[1]	[0]
0x51E					VDOX_HT [11:8]			
0x51F	VDOX_HT [7:0]							

**VDOX\_HT**      The total pixel number per line including horizontal blanking for the display digital output timing

**Page 6: 0x600 ~ 0x620, 0x640 ~ 0x65F, 0x690 ~ 0x6FE**

Address	[7]	[6]	[5]	[4]	[3]	[2]	[1]	[0]
0x616	MD3_MASK_SEL		MD2_MASK_SEL		MD1_MASK_SEL		MD0_MASK_SEL	

**MDn\_MASK\_SEL** Decide the read out of MD\_MASKS in 0x690 ~ 0x6EF

0 Read the detected motion of port n VINA  
 1 Read the detected motion of port n VINB  
 2 Read the mask of port n VINA  
 3 Read the mask of port n VINB

MDn\_MASK\_SEL also decide the write MD\_MASKS in 0x690 ~ 0x6EF

0 Write the mask for port n VINA  
 1 Write the mask for port n VINB

Address	[7]	[6]	[5]	[4]	[3]	[2]	[1]	[0]
0x617	MD_BASE_ADDR[4:0]							
0x618					MD_BASE_ADDR[8:5]			

**MD\_BASE\_ADDR** The base address of the motion detection buffer. This address is in unit of 64K bytes. The generated DDR address will be {MD\_BASE\_ADDR, 16'h0000}. The default value should be 9'h0CF

Address	[7]	[6]	[5]	[4]	[3]	[2]	[1]	[0]
0x619							MD_PALNT	MD_TEST_EN

**MD\_PALNT** Same as video decoder PALNT, need to be pull from bit 0 of 0x000, 0x010, 0x020, and 0x030 (To be fixed)

**MD\_TEST\_EN** Enable test pattern (not implemented)

Address	[7]	[6]	[5]	[4]	[3]	[2]	[1]	[0]
0x61A			MD_DIS	MD_DUAL_EN	MD_STRB	MD_STRB_EN	BD_CELLSSENS	
0x61B	MD_TMPSENS				MD_PIXEL_OS			
0x61C	MD_REFFLD	MD_FIELD		MD_LVSSENS				
0x61D	MD_CELSENS		MD_SPEED					
0x61E	MD_SPSSENS				BD_LVSSENS			
0x61F	ND_TMPSENS				ND_LVSSENS			

Register 0x61A ~ 0x61F are used to control the motion detection of 8 inputs (A / B inputs of 4 video decoders). In order to select the specific input to control, set the corresponding bit of MDCH\_SEL in 0x676.

**MD\_DIS** Disable the motion and blind detection.

0 Enable motion and blind detection (default)  
 1 Disable motion and blind detection

**MD\_DUAL\_EN** Enable pseudo 8 channel for motion detection

<b>MD_STRB</b>	Request to start motion detection on manual trigger mode 0 None Operation (default) 1 Request to start motion detection
<b>MD_STRB_EN</b>	Select the trigger mode of motion detection 0 Automatic trigger mode of motion detection (default) 1 Manual trigger mode for motion detection
<b>BD_CELSENS</b>	Define the threshold of cell for blind detection. 0 Low threshold (More sensitive) (default) : 3 High threshold (Less sensitive)
<b>MD_TMPSENS</b>	Control the temporal sensitivity of motion detector. 0 More Sensitive (default) : 15 Less Sensitive
<b>MD_PIXEL_OS</b>	Adjust the horizontal starting position for motion detection 0 0 pixel (default) : 15 15 pixels
<b>MD_REFFLD</b>	Control the updating time of reference field for motion detection. 0 Update reference field every field (default) 1 Update reference field according to MD_SPEED
<b>MD_FIELD</b>	Select the field for motion detection. 0 Detecting motion for only odd field (default) 1 Detecting motion for only even field 2 Detecting motion for any field 3 Detecting motion for both odd and even field
<b>MD_LVSENS</b>	Control the level sensitivity of motion detector. 0 More sensitive (default) : 31 Less sensitive
<b>MD_CELSENS</b>	Define the threshold of sub-cell number for motion detection. 0 Motion is detected if 1 sub-cell has motion (More sensitive) (default) 1 Motion is detected if 2 sub-cells have motion 2 Motion is detected if 3 sub-cells have motion 3 Motion is detected if 4 sub-cells have motion (Less sensitive)
<b>MD_SPEED</b>	Control the velocity of motion detector. Large value is suitable for slow motion detection. In MD_DUAL_EN = 1, MD_SPEED should be limited to 0 ~ 31. 0 1 field intervals (default) 1 2 field intervals : 61 62 field intervals 62 63 field intervals 63 Not supported
<b>MD_SPSENS</b>	Control the spatial sensitivity of motion detector. 0 More Sensitive (default)

:  
 15      Less Sensitive  
  
**BD\_LVSENS**      Define the threshold of level for blind detection.  
 0      Low threshold (More sensitive) (default)  
 :  
 15      High threshold (Less sensitive)  
  
**ND\_TMPSENS**      Define the threshold of temporal sensitivity for night detection.  
 0      Low threshold (More sensitive) (default)  
 :  
 15      High threshold (Less sensitive)  
  
**ND\_LVSENS**      Define the threshold of level for night detection.  
 0      Low threshold (More sensitive) (default)  
 :  
 15      High threshold (Less sensitive)

Address	[7]	[6]	[5]	[4]	[3]	[2]	[1]	[0]
0x620	0	0	BLINK_PERIOD					

**BLINK\_PERIOD**      Define the blinking time from on to off and off to on

Address	[7]	[6]	[5]	[4]	[3]	[2]	[1]	[0]
0x640			OSG_MEM_WIDTH					

**OSG\_MEM\_WIDTH**      The OSG memory structure width in units of 64 pixels (128 bytes)

Address	[7]	[6]	[5]	[4]	[3]	[2]	[1]	[0]
0x641	OSG_WRBASE_ADDR							

**OSG\_WRBASE\_ADDR**      The base address used for writing data into OSG memory space. This base address can be set statically to treat all the OSG memory space into a big one, or it can be set dynamically to match each of the OSG base address at the write side. The unit is in 64 Kbytes. The DDR address generated from this register is {1'b1, OSG\_WRBASE\_ADDR[7:0], 16'h0}

Address	[7]	[6]	[5]	[4]	[3]	[2]	[1]	[0]
0x642	0		OSG_COLR_CON	0	1	1	OSG_OPMODE	

<b>OSG_COLR_CON</b>	<b>1</b>	Turn on color conversion before writing into the memory. There is a 4-entry color conversion table used to match with the pixel value. If it matches, the pixel is converted to a specified corresponding output pixel value.
	<b>0</b>	Turn off the color conversion function
<b>OSG_OPMODE</b>	<b>0</b>	Bitmap Write Mode – CPU fill all the pixel bitmaps
	<b>1</b>	Block Move Mode – Move one block of memory content from one location to another location
	<b>2</b>	Block Fill Mode
	<b>3</b>	Reserved

Address	[7]	[6]	[5]	[4]	[3]	[2]	[1]	[0]
0x645	OSG_SRC_SH[10:8]			OSG_SRC_SV[10:8]				
0x646	OSG_SRC_SV[7:0]							
0x647	OSG_SRC_SH[7:0]							
0x648	OSG_DST_EH[10:8]			OSG_DST_EV[10:8]				
0x649	OSG_DST_EV[7:0]							
0x64A	OSG_DST_EH[7:0]							
0x64B	OSG_DST_SH[10:8]			OSG_DST_SV[10:8]				
0x64C	OSG_DST_SV[7:0]							
0x64D	OSG_DST_SH[7:0]							

<b>OSG_SRC_SV</b>	The start line of the source block
<b>OSG_SRC_SH</b>	The starting pixel of the source block.
<b>OSG_DST_EV</b>	The end line of the destination block
<b>OSG_DST_EH</b>	The end pixel of the destination block
<b>OSG_DST_SV</b>	The starting line of the destination block
<b>OSG_DST_SH</b>	The starting pixel of the destination block.

Address	[7]	[6]	[5]	[4]	[3]	[2]	[1]	[0]
0x64E	SELOSG				0	OSG_INDRD	OSG_INDWR	0

<b>OSG_INDWR</b>	Write 1 to start indirect write command for on-chip table selected by OSG_SELOSG. Write only
<b>OSG_INDRD</b>	Write 1 to start indirect read command from on-chip table selected by OSG_SELOSG. Write only
<b>OSG_SELOSG</b>	0: Color conversion table. Others: reserved.

Address	[7]	[6]	[5]	[4]	[3]	[2]	[1]	[0]
0x64F	OSG_IDLE		OSG_BMWR_BUSY				OSG_OP_START	

<b>OSG_OP_START</b>	Command bit to start the BLOCK MOVE, BLOCK FILL, or BITMAP WRITE function. Self clear after done. This bit can be used as status bit for whether the OSG is ready for a new operation. If it is 0, means the previous operation is done. Note: do not write 0 to this bit. It may cause unexpected result.
<b>OSG_BMWR_BUSY</b>	Read only flag to specify whether the BITMAP WRITE fifo has 256 byte space available to write. If this bit is 0, the MCU can feel free to write up to 256 bytes without checking this bit again.
<b>OSG_IDLE</b>	Read only flag to specify OSG state machine is idle. This bit is usually the opposite of the OSG_OP_START (0x64F[0]), unless OSG_OP_START was set at incorrect time during OSG_IDLE is not 1.  0      OSG operation is in progress 1      OSG operation is idle

Address	[7]	[6]	[5]	[4]	[3]	[2]	[1]	[0]
0x650	OSG_IND_ADDR							

**OSG\_IND\_ADDR**      The indirect access address used to access the internal tables.

Address	[7]	[6]	[5]	[4]	[3]	[2]	[1]	[0]
0x651	OSG_IND_WRDATA							

**OSG\_IND\_WRDATA**      The indirect write data for writing the color table.

Address	[7]	[6]	[5]	[4]	[3]	[2]	[1]	[0]
0x652	OSG_UP_DATA[15:0] or OSG_UP_DATA[7:0]							

**OSG\_UP\_DATA**      The BITMAP WRITE data register. Note that in the 16-bit data bus mode, this address is used to write 16 bits, instead of 8 bits.

Address	[7]	[6]	[5]	[4]	[3]	[2]	[1]	[0]
0x654	OSG_FILL_COLR[7:0] (Y2)							
0x655	OSG_FILL_COLR[15:8] (Cr)							
0x656	OSG_FILL_COLR[23:16] (Y1)							
0x657	OSG_FILL_COLR[31:24] (Cb)							

OSG\_FILL\_COLR[31:24] U pixel value for block fill  
 OSG\_FILL\_COLR[23:16] Y1 pixel value for block fill  
 OSG\_FILL\_COLR[15:8]      V pixel value for block fill  
 OSG\_FILL\_COLR[7:0]      Y2 pixel value for block fill

Address	[7]	[6]	[5]	[4]	[3]	[2]	[1]	[0]
0x658	OSG_RLC_EN			OSG_RLC_32B	OSG_RLC_CNT			

**OSG\_RLC\_EN**      Enable proprietary hardware RLC decompression while uploading the bitmap into the OSG buffer. With this feature turned on, the

uploading bitmap from MCU through the host interface is in RLC compressed format. The RLC compressed result is decompressed by the hardware automatically. This reduces the bandwidth consumption on the host interface.

<b>OSG_RLC_32B</b>	<b>1</b>	Use 32 bit data for compression pattern match
	<b>0</b>	Use 16 bit data for compression pattern match
<b>OSG_RLC_CNT</b>		Indicate how many bits are used for the repetition count.
	<b>0</b>	The repetition count is 16 bits
	<b>1 - 15</b>	The repetition count is 1 - 15 bits

The proprietary compression format is as follows:

F, D/C, F, D/C, .....

<b>Where F (1 bit):</b>	<b>0</b> : indicate the following is pixel data
	<b>1</b> : indicate the following is repetition count
<b>D :</b>	Pixel Data in either 16 bits or 32 bits, as specified by OSG_RLC_32B)
<b>C :</b>	Repetition count (how many times the D data is repeated. The number of bits of this repetition count is controlled by the OSG_RLC_CNT.

Note: count of 0 means  $2^{**}N$  repetition, where N is OSG\_RLC\_CNT

Address	[7]	[6]	[5]	[4]	[3]	[2]	[1]	[0]
0x65B								CUR_EN

<b>CUR_EN</b>	Enable the 5 OSD cursors. Only one of the 5 should be turned on.
<b>Bit 0:</b>	Display VGA OSD
<b>Bit 1:</b>	Display CVBS OSD
<b>Bit 2:</b>	Record 0 OSD
<b>Bit 3:</b>	Record 1 OSD
<b>Bit 4:</b>	SPOT OSD



Address	[7]	[6]	[5]	[4]	[3]	[2]	[1]	[0]
0x65C	CUR_REV	CUR_BLINK	CUR_HOLLOW_OFF	CUR_CUSTOM_LD				CUR_SEL

<b>CUR_REV</b>	Reverse the cursor color (black become white, white become black)
<b>CUR_BLINK</b>	Enable blink of mouse pointer. 0 Disable cursor blinking (default) 1 Enable cursor blinking
<b>CUR_HOLLOW_OFF</b>	Control interior pixel color of the cursor. 0 Hollow cursor shape (only the border pixels are shown) (default) 1 Filled with solid color specified by the cursor pixel
<b>CUR_CUSTOM_LD</b>	Load the customized cursor shape from DDR memory into the on chip SRAM
<b>CUR_SEL</b>	Select the cursor type 0 Small cursor 1 Normal cursor 2 Customized cursor implemented with SRAM 3 Reserved

Address	[7]	[6]	[5]	[4]	[3]	[2]	[1]	[0]
0x65D			CUR_Y[10:8]				CUR_X[10:8]	
0x65E	CUR_X[7:0]							
0x65F	CUR_Y[7:0]							

<b>CUR_X</b>	Control the horizontal location of mouse pointer. 0 0 Pixel position (default) : : 1440 1440 Pixel position
<b>CUR_Y</b>	Control the vertical location of mouse pointer. 0 0 Line position (default) : : 900 900 Line position

Registers 0x690 ~ 0x6EF are used to control the mask of input A / B of each video decoder. To access the corresponding inputs, set the corresponding MDn\_MASK\_SEL in 0x616.

Address	[7]	[6]	[5]	[4]	[3]	[2]	[1]	[0]
0x690								MDO_MASK0[7:0]
0x691								MDO_MASK0[15:8]
0x692								MDO_MASK1[7:0]
0x693								MDO_MASK1[15:8]
0x694								MDO_MASK2[7:0]
0x695								MDO_MASK2[15:8]
0x696								MDO_MASK3[7:0]
0x697								MDO_MASK3[15:8]
0x698								MDO_MASK4[7:0]
0x699								MDO_MASK4[15:8]
0x69A								MDO_MASK5[7:0]
0x69B								MDO_MASK5[15:8]
0x69C								MDO_MASK6[7:0]
0x69D								MDO_MASK6[15:8]
0x69E								MDO_MASK7[7:0]
0x69F								MDO_MASK7[15:8]
0x6A0								MDO_MASK8[7:0]
0x6A1								MDO_MASK8[15:8]
0x6A2								MDO_MASK9[7:0]
0x6A3								MDO_MASK9[15:8]
0x6A4								MDO_MASK10[7:0]
0x6A5								MDO_MASK10[15:8]
0x6A6								MDO_MASK11[7:0]
0x6A7								MDO_MASK11[15:8]

Address	[7]	[6]	[5]	[4]	[3]	[2]	[1]	[0]
0x6A8								MD1_MASK0[7:0]
0x6A9								MD1_MASK0[15:8]
0x6AA								MD1_MASK1[7:0]
0x6AB								MD1_MASK1[15:8]
0x6AC								MD1_MASK2[7:0]
0x6AD								MD1_MASK2[15:8]
0x6AE								MD1_MASK3[7:0]
0x6AF								MD1_MASK3[15:8]
0x6B0								MD1_MASK4[7:0]
0x6B1								MD1_MASK4[15:8]
0x6B2								MD1_MASK5[7:0]
0x6B3								MD1_MASK5[15:8]
0x6B4								MD1_MASK6[7:0]
0x6B5								MD1_MASK6[15:8]
0x6B6								MD1_MASK7[7:0]
0x6B7								MD1_MASK7[15:8]
0x6B8								MD1_MASK8[7:0]
0x6B9								MD1_MASK8[15:8]
0x6BA								MD1_MASK9[7:0]
0x6BB								MD1_MASK9[15:8]
0x6BC								MD1_MASK10[7:0]
0x6BD								MD1_MASK10[15:8]

Address	[7]	[6]	[5]	[4]	[3]	[2]	[1]	[0]
0x6BE	MD1_MASK11[7:0]							
0x6BF	MD1_MASK11[15:8]							

Address	[7]	[6]	[5]	[4]	[3]	[2]	[1]	[0]
0x6C0	MD2_MASK0[7:0]							
0x6C1	MD2_MASK0[15:8]							
0x6C2	MD2_MASK1[7:0]							
0x6C3	MD2_MASK1[15:8]							
0x6C4	MD2_MASK2[7:0]							
0x6C5	MD2_MASK2[15:8]							
0x6C6	MD2_MASK3[7:0]							
0x6C7	MD2_MASK3[15:8]							
0x6C8	MD2_MASK4[7:0]							
0x6C9	MD2_MASK4[15:8]							
0x6CA	MD2_MASK5[7:0]							
0x6CB	MD2_MASK5[15:8]							
0x6CC	MD2_MASK6[7:0]							
0x6CD	MD2_MASK6[15:8]							
0x6CE	MD2_MASK7[7:0]							
0x6CF	MD2_MASK7[15:8]							
0x6D0	MD2_MASK8[7:0]							
0x6D1	MD2_MASK8[15:8]							
0x6D2	MD2_MASK9[7:0]							
0x6D3	MD2_MASK9[15:8]							
0x6D4	MD2_MASK10[7:0]							
0x6D5	MD2_MASK10[15:8]							
0x6D6	MD2_MASK11[7:0]							
0x6D7	MD2_MASK11[15:8]							

Address	[7]	[6]	[5]	[4]	[3]	[2]	[1]	[0]
0x6D8	MD3_MASK0[7:0]							
0x6D9	MD3_MASK0[15:8]							
0x6DA	MD3_MASK1[7:0]							
0x6DB	MD3_MASK1[15:8]							
0x6DC	MD3_MASK2[7:0]							
0x6DD	MD3_MASK2[15:8]							
0x6DE	MD3_MASK3[7:0]							
0x6DF	MD3_MASK3[15:8]							
0x6E0	MD3_MASK4[7:0]							
0x6E1	MD3_MASK4[15:8]							
0x6E2	MD3_MASK5[7:0]							
0x6E3	MD3_MASK5[15:8]							
0x6E4	MD3_MASK6[7:0]							
0x6E5	MD3_MASK6[15:8]							
0x6E6	MD3_MASK7[7:0]							
0x6E7	MD3_MASK7[15:8]							
0x6E8	MD3_MASK8[7:0]							
0x6E9	MD3_MASK8[15:8]							
0x6EA	MD3_MASK9[7:0]							
0x6EB	MD3_MASK9[15:8]							

Address	[7]	[6]	[5]	[4]	[3]	[2]	[1]	[0]
0x6EC	MD3_MASK10[7:0]							
0x6ED	MD3_MASK10[15:8]							
0x6EE	MD3_MASK11[7:0]							
0x6EF	MD3_MASK11[15:8]							

**MDx\_MASK** Define the motion Mask/Detection cell for VIN x. MD\_MASK[15] is right end and MD\_MASK[0] is left end of column.

In writing mode

- 0 Non-masking cell for motion detection (default)
- 1 Masking cell for motion detection

In reading mode when MDn\_MASK\_SEL= "0"

- 0 Motion is not detected for cell
- 1 Motion is detected for cell

In reading mode when MDn\_MASK\_SEL= "1"

- 0 Non-masked cell
- 1 Masked cell

Address	[7]	[6]	[5]	[4]	[3]	[2]	[1]	[0]
0x6F0	MD_STRB_DET*							

\*Read only bit

**MD\_STRBn**                    1      MD strobe has been performed at channel n  
    0      MD strobe has not yet been performed at channel n

Address	[7]	[6]	[5]	[4]	[3]	[2]	[1]	[0]
0x6F1	NOVID_DET_0B*	MD_DET_0B*	BD_DET_0B*	ND_DET_0B*	NOVID_DET_0A*	MD_DET_0A*	BD_DET_0A*	ND_DET_0A*
0x6F2	NOVID_DET_1B*	MD_DET_1B*	BD_DET_1B*	ND_DET_1B*	NOVID_DET_1A*	MD_DET_1A*	BD_DET_1A*	ND_DET_1A*
0x6F3	NOVID_DET_2B*	MD_DET_2B*	BD_DET_2B*	ND_DET_2B*	NOVID_DET_2A*	MD_DET_2A*	BD_DET_2A*	ND_DET_2A*
0x6F4	NOVID_DET_3B*	MD_DET_3B*	BD_DET_3B*	ND_DET_3B*	NOVID_DET_3A*	MD_DET_3A*	BD_DET_3A*	ND_DET_3A*

\*Read only bits

**NOVID\_DET\_mA**                    NO\_VIDEO Detected from port m, analog path A (read only)

**NOVID\_DET\_mB**                    NO\_VIDEO Detected from port m, analog path B (read only)

**MD\_DET\_mA**                        Motion Detected from port m, analog path A (read only)

**MD\_DET\_mB**                        Motion Detected from port m, analog path B (read only)

**BD\_DET\_mA**                        Blind Detected from port m, analog path A (read only)

**BD\_DET\_mB**                        Blind Detected from port m, analog path B (read only)

**ND\_DET\_mA**                        Night Detected from port m, analog path A (read only)

**ND\_DET\_mB**                        Night Detected from port m, analog path B

**Page 9: 0x9C0 ~ 0x9DF**

Address	[7]	[6]	[5]	[4]	[3]	[2]	[1]	[0]
0x9C0	DDC_FREQ_DIV[7:0]							
0x9C1	DDC_FREQ_DIV[15:8]							

**DDC\_FREQ\_DIV**

DDC I2C Clock Generator generates DDC\_CLK from an internal 54 MHz clock divided by DDC\_FREQ\_DIV.

Address	[7]	[6]	[5]	[4]	[3]	[2]	[1]	[0]
0x9C2	DDC_WR_DATA							

**DDC\_WR\_DATA****DDC I2C Write Data Register**

At the start operation, the content is as follows

Slave_Device_Addr	DDC_WR_DATA[7:1]
R/W Command	DDC_WR_DATA[0]
	1 Read
	0 Write

Address	[7]	[6]	[5]	[4]	[3]	[2]	[1]	[0]
0x9C3	DDC_RD_DATA							

**DDC\_RD\_DATA****DDC I2C Read Data Register**

Address	[7]	[6]	[5]	[4]	[3]	[2]	[1]	[0]
0x9C4	DDC_COMMAND							

**DDC\_COMMAND****DDC Control Command (Read/Write)**

7	I2C Start
6	I2C Stop
5	Read the value from the slave device register. Once acknowledged, the data will be in DDC_RD_DATA register
4	Write the value in DDC_WR_DATA onto DDC_DATA bus
3	Send an ACK to the DDC_DATA bus when read
2	Clock Count Enable
1	Interrupt Enable
0	Interrupt Acknowledge

Address	[7]	[6]	[5]	[4]	[3]	[2]	[1]	[0]
0x9C5	DDC_STATUS							

DDC\_STATUS

DDC Status Register (read only)

Bit 7 RXACK  
 Bit 6 I2C\_BUSY  
 Bit 5 Active Low  
 Bit 4 0  
 Bit 3 0  
 Bit 2 0  
 Bit 1 I2C Read/Write  
 Bit 0 Interrupt Acknowledge

Address	[7]	[6]	[5]	[4]	[3]	[2]	[1]	[0]
0x9C7	0							

Reserved

Should be kept 0

Address	[7]	[6]	[5]	[4]	[3]	[2]	[1]	[0]
0x9CF	DDC_RST							

DDC\_RST

DDC Software Reset whenever CPU issues a write to this address

Address	[7]	[6]	[5]	[4]	[3]	[2]	[1]	[0]
0x9D0	PS2_MaxNoSig			PS2_MaxByte		PS2_WR_EN	PS2_EN	

PS2\_MaxNoSig

Specify the length of time used to flag no signal when PS2\_CK is not toggled.

PS2\_MaxByte

Maximum number of bytes used in PS2 read operation from PS2\_D

PS2\_WR\_EN

PS2 Data Write Enable to write data in PS2\_WR\_DATA onto PS2\_D

PS2\_EN

PS2 Enable

Address	[7]	[6]	[5]	[4]	[3]	[2]	[1]	[0]
0x9D1	PS2_WR_DATA							

PS2\_WR\_DATA

Before writing this register, make sure the 0x9D0 control is written with PS2\_WR\_EN = 1 and PS2\_EN = 1.

Once writing into this register, the PS2 interface start sending PS2\_WR\_DATA onto PS2\_D bus.

Address	[7]	[6]	[5]	[4]	[3]	[2]	[1]	[0]
0x9D2	PS2_RD_DATA[7:0]							
0x9D3	PS2_RD_DATA[15:8]							
0x9D4	PS2_RD_DATA[23:16]							
0x9D5	PS2_RD_DATA[31:24]							

PS2\_RD\_DATA

Data read back from PS2 port. If PS2\_WR\_EN = 0, and PS2\_EN = 1, and the PS2 Interrupt is asserted, the data on PS2\_D bus are available in these registers. The maximum number of valid bytes is determined by PS2\_MaxByte in 0x9D0

Address	[7]	[6]	[5]	[4]	[3]	[2]	[1]	[0]
0x9DF	PS2_RST							

PS2\_RST

PS2 Software Reset whenever CPU issues a write to this address

### Page M: 0xM21 ~ 0xM3F, 0xM60 ~ 0xM8F, where M = 5 ~ 9

M=5: VGA OSD, M=6: Display CVBS OSD, M=7: REC0\_OSD, M=8: REC1\_OSD, M=9: SPOT\_OSD

Address	[7]	[6]	[5]	[4]	[3]	[2]	[1]	[0]
0x521 0x621 0x721 0x821 0x921	0	0					OSD_FLD_POL	OSD_VSYNC_POL

OSD\_FLD\_POL

The Polarity control for the OSD to interpret the field signal

OSD\_VSYNC\_POL

The polarity control for the OSD to interpret the VS when signal

Address	[7]	[6]	[5]	[4]	[3]	[2]	[1]	[0]
0x530 0x630 0x730 0x830 0x930								OSD_BLINK_EN
0x531 0x631 0x731 0x831 0x931	OSD_TEST				OSD_WINSEL[7:0]			

**OSD\_BLINK\_EN**      Enable blinking

**OSD\_TEST**      OSD Test pattern. For internal use only

**OSD\_WINSEL[n]**      Selects which window to configure. This is used with registers  
0xm35,  
0xm37 ~ 0xm3F.  
0 ~ 7      Sub-windows  
8      Main Window



Address	[7]	[6]	[5]	[4]	[3]	[2]	[1]	[0]
0x532 0x632 0x732 0x832 0x932	OSD_GLOBAL_ALPHA1 (Main Window)							
0x533 0x633 0x733 0x833 0x933	OSD_GLOBAL_ALPHA2 (Sub Windows)							

**OSD\_GLOBAL\_ALPHA1** The alpha value for main window

**OSD\_GLOBAL\_ALPHA2** The alpha value for all sub-windows

Address	[7]	[6]	[5]	[4]	[3]	[2]	[1]	[0]
0x534 0x634 0x734 0x834 0x934	0	0	OSD_BLEND_OPT	OSD_WINSUB_ON	OSD_WINMAIN_ON	OSD_P_ALPHA	OSD_MODE[1]	OSD_MODE[0]

**OSD\_BLEND\_OPT** Decide whether single window OSD layer on top or multi-window OSD layer on top when blending

**OSD\_WINSUB\_ON** Turn on sub-window OSD. Each individual sub-window is enabled by **OSD\_WIN\_EN** in 0xm35

**OSD\_WINMAIN\_ON** Turn on the main window OSD

**OSD\_P\_ALPHA** (reserved)

**OSD\_MODE[1:0]** For VGA OSD(0x534)  
 00: 422 UYVY format  
 01: 565 UYV format  
 11: 565 RGB format  
 For other OSD (0x634/0x734/0x834/0x934)  
 Always 422 UYVY format

Address	[7]	[6]	[5]	[4]	[3]	[2]	[1]	[0]
0x535 0x635 0x735 0x835 0x935	OSD_BLINK_TIME		OSD_WINSWITCH	OSD_WINSET			OSD_WIN_EN	

- OSD\_BLINK\_TIME** Enable blinking of the window specified by **OSD\_WINSEL** in 0xm31. This bit is written into the corresponding window when **OSD\_WINSET** is set to 1.
- 0 blink every 8 VSYNC  
1 blink every 16 VSYNC  
2 blink every 32 VSYNC  
3 blink every 64 VSYNC
- OSD\_WINSWITCH** Enable the dynamic field based OSD switching for record / SPOT OSD
- OSD\_WINSET** Write command to write to one of the 9 windows configuration registers. This bit is not self cleared. It requires a clear before setting to 1 again.
- OSD\_WIN\_EN** Enable the window specified by **OSD\_WINSEL** in 0xm31. This bit is written into the corresponding window when the **OSD\_WINSET** is set to 1.

Address	[7]	[6]	[5]	[4]	[3]	[2]	[1]	[0]
0x536 0x636 0x736 0x836 0x936	OSD_RDBASE_ADDR							

- OSD\_RDBASE\_ADDR** The base address of the current OSD. Each OSD can have its own base address. This address is in unit of 64 KB. The derived DDR address will be { 1'b1, OSD\_RDBASE\_ADDR, 16'h0000 }

Address	[7]	[6]	[5]	[4]	[3]	[2]	[1]	[0]
0x537 0x637 0x737 0x837 0x937	OSD_SRC_SH[11:8]				OSD_SRC_SV[11:8]			
0x538 0x638 0x738 0x838 0x938	OSD_SRC_SV[7:0]							
0x539 0x639 0x739 0x839 0x939	OSD_SRC_SH[7:0]							
0x53A 0x63A 0x73A 0x83A 0x93A	OSD_DST_EH[11:8]				OSD_DST_EV[11:8]			
0x53B 0x63B 0x73B 0x83B 0x93B	OSD_DST_EV[7:0]							
0x53C 0x63C 0x73C 0x83C 0x93C	OSD_DST_EH[7:0]							
0x53D 0x63D 0x73D 0x83D 0x93D	OSD_DST_SH[11:8]				OSD_DST_SV[11:8]			
0x53E 0x63E 0x73E 0x83E 0x93E	OSD_DST_SV[7:0]							
0x53F 0x63F 0x73F 0x83F 0x93F	OSD_DST_SH[7:0]							

The following register setting are saved into the corresponding OSD window specified by OSD\_WINSEL in 0xm31 when the OSD\_WINSET bit is set to 1.

OSD_SRC_SV	Starting line of the source block in the OSD memory
OSD_SRC_SH	Starting pixel of the source block in the OSD memory
OSD_DST_EV	Ending line of the OSD on the destination video stream
OSD_DST_EH	End pixel location of the OSD on the destination video stream. This should be the starting location OSD_DST_SH + OSD_WIDTH.
OSD_DST_SV	Starting line of the OSD on the destination video stream
OSD_DST_SH	Starting pixel location of the OSD on the destination video stream.

Address	[7]	[6]	[5]	[4]	[3]	[2]	[1]	[0]
0x564 0x664 0x764 0x864 0x964	BOX1D_ALPHA1				BOX1D_ALPHA0			

**BOX1D\_ALPHA0** The alpha value for the 6 1DBOXs below the bitmap OSG layer (1D box 2 ~ 7)

**BOX1D\_ALPHA1** The alpha value for the 2 1DBOXs above the bitmap OSG layer (1D box 0 ~ 1)

Address	[7]	[6]	[5]	[4]	[3]	[2]	[1]	[0]
0x566 0x666 0x766 0x866 0x966	MOSAIC_COLOR_SEL1				MOSAIC_COLOR_SELO			

**MOSAIC\_COLOR\_SELO** Mosaic color selection for the 6 1D Boxes below the bitmap OSG layer

**MOSAIC\_COLOR\_SEL1** Mosaic color selection for the 2 1D Boxes above the bitmap OSG layer

- 0 White (75% Amplitude 100% Saturation)
- 1 Yellow (75% Amplitude 100% Saturation)
- 2 Cyan (75 % Amplitude 100 Saturation)
- 3 Green (75% Amplitude 100% Saturation)
- 4 Magenta (75% Amplitude 100% Saturation)
- 5 Red (75% Amplitude 100% Saturation)
- 6 Blue (75% Amplitude 100% Saturation)
- 7 0% Black
- 8 100% White
- 9 50% Gray
- 10 25% Gray
- 11 Blue (75% Amplitude 75% Saturation)
- 12 Defined by CLUT0 in 0xm78, 0xm7C, 0xm80
- 13 Defined by CLUT1 in 0xm79, 0xm7D, 0xm81
- 14 Defined by CLUT2 in 0xm7A, 0xm7E, 0xm82
- 15 Defined by CLUT3 in 0xm7B, 0xm7F, 0xm83

Address	[7]	[6]	[5]	[4]	[3]	[2]	[1]	[0]
0x567 0x667 0x767 0x867 0x967	BOX1D_EN							

**BOX1D\_EN** [1] Enable the upper layer with 2 Single Boxes (1D Box 0 ~ 1)  
[0] Enable the lower layer with 6 Single Boxes (1D box 2 ~ 7)

Address	[7]	[6]	[5]	[4]	[3]	[2]	[1]	[0]
0x568 0x668 0x768 0x868					MOSAIC_EN	BOX1D_MIX_EN	BOX1D_BDR_EN	BOX1D_INT_EN

0x968								
0x569 0x669 0x769 0x869 0x969			BOX1D_BDR_COLR			BOX1D_COLR		
0x56A 0x66A 0x76A 0x86A 0x96A			BOX1D_VT[9:8]			BOX1D_HL[10:8]		
0x56B 0x66B 0x76B 0x86B 0x96B	BOX1D_HL[7:0]							
0x56C 0x66C 0x76C 0x86C 0x96C	BOX1D_VT[7:0]							
0x56D 0x66D 0x76D 0x86D 0x96D			BOX1D_VW[9:8]			BOX1D_HW[10:8]		
0x56E 0x66E 0x76E 0x86E 0x96E	BOX1D_HW[7:0]							
0x56F 0x66F 0x76F 0x86F 0x96F	BOX1D_VW[7:0]							

Register 0xm68 ~ 0xm6F are used to control 8 sets of 1D-boxes. In order to access the 1D box to control, use MDCH\_SEL in 0xm76 to enable the corresponding bit before accessing these registers.

<b>MOSAIC_EN[m]</b>	Turn on the MOSAIC pattern in the 1D Box.
<b>BOX1D_MIX_EN</b>	Transparent blending enable
<b>BOX1D_BDR_EN</b>	Enable showing the border line
<b>BOX1D_INT_EN</b>	Enable showing the interior pixel color
<b>BOX1D_BDR_COLR</b>	Define the box boundary color for each box 0 0% White (Default) 1 25% White 2 50% White 3 75% White
<b>BOX1D_COLR</b>	Define the interior pixel colors 0 White (75% Amplitude 100% Saturation) 1 Yellow (75% Amplitude 100% Saturation) 2 Cyan (75 % Amplitude 100 Saturation) 3 Green (75% Amplitude 100% Saturation) 4 Magenta (75% Amplitude 100% Saturation) 5 Red (75% Amplitude 100% Saturation) 6 Blue (75% Amplitude 100% Saturation) 7 0% Black

---

<b>8</b>	<b>100% White</b>
<b>9</b>	<b>50% Gray</b>
<b>10</b>	<b>25% Gray</b>
<b>11</b>	<b>Blue (75% Amplitude 75% Saturation)</b>
<b>12</b>	<b>Defined by CLUT0 in 0xm78, 0xm7C, 0xm80</b>
<b>13</b>	<b>Defined by CLUT1 in 0xm79, 0xm7D, 0xm81</b>
<b>14</b>	<b>Defined by CLUT2 in 0xm7A, 0xm7E, 0xm82</b>
<b>15</b>	<b>Defined by CLUT3 in 0xm7B, 0xm7F, 0xm83</b>

**BOX1D\_HL** Define the horizontal left location of box.

<b>0</b>	<b>Left end (default)</b>
<b>:</b>	<b>:</b>
<b>1439</b>	<b>Right end</b>

**BOX1D\_VT** Define the vertical top location of box.

<b>0</b>	<b>Vertical top (default)</b>
<b>:</b>	<b>:</b>
<b>899</b>	<b>Vertical bottom</b>

**BOX1D\_HW** Define the horizontal size of box.

<b>0</b>	<b>1 Pixel width (default)</b>
<b>:</b>	<b>:</b>
<b>1439</b>	<b>1440 Pixels width</b>

**BOX1D\_VW** Define the vertical size of box.

<b>0</b>	<b>1 Lines height (default)</b>
<b>:</b>	<b>:</b>
<b>899</b>	<b>900 Lines height</b>

Address	[7]	[6]	[5]	[4]	[3]	[2]	[1]	[0]
0x575 0x675 0x775 0x875 0x975		MDBOX_EN					MD_BND_MERG	MDBOX_ALPHA

**MDBOX\_EN** Enable the Motion 2D Box function

**MD\_BND\_MERG** Turn on the 2D Box merge if two adjacent box are both on

**MDBOX\_ALPHA** Select the alpha blending mode for 2D arrayed Box

0 50% (default)

1 50%

2 75%

3 25%

Address	[7]	[6]	[5]	[4]	[3]	[2]	[1]	[0]
0x576 0x676 0x776 0x876 0x976								MDCH_SEL

**MDCH\_SEL** Select one of the 8 1DBOXs to configure using 0xm68 ~ 0xm6F or one of the 8 Motion 2D Boxes to configure using 0xm84 ~ 0xm8F.

Address	[7]	[6]	[5]	[4]	[3]	[2]	[1]	[0]
0x578 0x678 0x778 0x878 0x978								MD_CLUT0_Y
0x579 0x679 0x779 0x879 0x979								MD_CLUT1_Y
0x57A 0x67A 0x77A 0x87A 0x97A								MD_CLUT2_Y
0x57B 0x67B 0x77B 0x87B 0x97B								MD_CLUT3_Y
0x57C 0x67C 0x77C 0x87C 0x97C								MD_CLUT0_CB
0x57D 0x67D 0x77D 0x87D 0x97D								MD_CLUT1_CB
0x57E 0x67E 0x77E 0x87E 0x97E								MD_CLUT2_CB

Address	[7]	[6]	[5]	[4]	[3]	[2]	[1]	[0]
0x57F 0x67F 0x77F 0x87F 0x97F	MD_CLUT3_CB							
0x580 0x680 0x780 0x880 0x980	MD_CLUT0_CR							
0x581 0x681 0x781 0x881 0x981	MD_CLUT1_CR							
0x582 0x682 0x782 0x882 0x982	MD_CLUT2_CR							
0x583 0x683 0x783 0x883 0x983	MD_CLUT3_CR							

MD\_CLUTx\_Y                    Y component for user defined color 0 (default : 0)

MD\_CLUTx\_CB                Cb component for user defined color 0 (default : 0)

MD\_CLUTx\_CR                Cr component for user defined color 0 (default : 0)

Address	[7]	[6]	[5]	[4]	[3]	[2]	[1]	[0]
0x584 0x684 0x784 0x884 0x984					MDBOX_MODE			
0x585 0x685 0x785 0x885 0x985	MDDT_EN	MDMASK_EN	MDBOX_VINV	MDBOX_HINV	MDBOX_MIX	MDCUR_EN		MDBOXm_EN
0x586 0x686 0x786 0x886 0x986	MDDT_COLR				MDMASK_COLR			
0x587 0x687 0x787 0x887 0x987		MDBOX_VOS[10:8]				MDBOX_HOS[10:8]		
0x588 0x688 0x788 0x888 0x988	MDBOX_HOS[7:0]							
0x589 0x689 0x789 0x889 0x989	MDBOX_VOS[7:0]							
0x58A 0x68A 0x78A 0x88A		MDBOX_VW[10:8]				MDBOX_HW[10:8]		



Address	[7]	[6]	[5]	[4]	[3]	[2]	[1]	[0]
0x98A								
0x58B 0x68B 0x78B 0x88B 0x98B	MDBOX_HW[7:0]							
0x58C 0x68C 0x78C 0x88C 0x98C	MDBOX_VW[7:0]							
0x58D 0x68D 0x78D 0x88D 0x98D						MDBOX_BNDEN	MD_BNDRY_COLR	
0x58E 0x68E 0x78E 0x88E 0x98E	MDCUR_HPOS				MDCUR_VPOS			
0x58F 0x68F 0x78F 0x88F 0x98F	MDBOX_HCELL				MDBOX_VCELL			

Register 0xm84 ~ 0xm8F are used to control 8 sets of 2D boxes. In order to select the specific 2D box to control, use MDCH\_SEL in 0xm76 to enable the corresponding bit before accessing these registers.

<b>MDBOX_MODE</b>	Define the operation mode of 2D arrayed box. 0 Table mode (default) 1 Motion display mode
<b>MDDET_EN</b>	Enable the motion cell display when the corresponding mask bit is 0 When MDBOX_MODE = "0" 0 Disable the detection plane of 2D arrayed box (default) 1 Enable the detection cell of 2D arrayed box  When MDBOX_MODE = "1" 0 Display the motion detection result with inner boundary 1 Display the motion detection result with whole cell area
<b>MDMASK_EN</b>	Enable the mask plane of 2D arrayed box 0 Disable the mask plane of 2D arrayed box (default) 1 Enable the mask plane of 2D arrayed box
<b>MDBOX_VINV</b>	Enable the vertical mirroring for 2D arrayed box. 0 Normal operation (default) 1 Enable the vertical mirroring
<b>MDBOX_HINV</b>	Enable the horizontal mirroring for 2D arrayed box. 0 Normal operation (default) 1 Enable the horizontal mirroring
<b>MDBOX_MIX</b>	Enable the alpha blending for 2D arrayed box plane with video data. 0 Disable the alpha blending (default)

	<b>1</b>	Enable the alpha blending with MDBOX_ALPHA setting (0x575)
<b>MDCUR_EN</b>		Used to change the color of a cell to indicate the cell where the cursor is located
<b>MDBOXm_EN</b>		Enable the 2Dbox specified by 0xm76
	<b>0</b>	Disable the 2D box (default)
	<b>1</b>	Enable the 2D box
<b>MDMASK_COLR</b>		Define the color of Mask plane in 2D arrayed box. (default = 0)
<b>MDDET_COLR</b>		Define the color of Detection plane in 2D arrayed box. (default = 0)
	<b>0</b>	White (75% Amplitude 100% Saturation)
	<b>1</b>	Yellow (75% Amplitude 100% Saturation)
	<b>2</b>	Cyan (75 % Amplitude 100 Saturation)
	<b>3</b>	Green (75% Amplitude 100% Saturation)
	<b>4</b>	Magenta (75% Amplitude 100% Saturation)
	<b>5</b>	Red (75% Amplitude 100% Saturation)
	<b>6</b>	Blue (75% Amplitude 100% Saturation)
	<b>7</b>	0% Black
	<b>8</b>	100% White
	<b>9</b>	50% Gray
	<b>10</b>	25% Gray
	<b>11</b>	Blue (75% Amplitude 75% Saturation)
	<b>12</b>	Defined by CLUTO
	<b>13</b>	Defined by CLUT1
	<b>14</b>	Defined by CLUT2
	<b>15</b>	Defined by CLUT3
<b>MDBOX_VOS</b>		Define the vertical top location of 2D arrayed box.
	<b>0</b>	Vertical top end (default)
	:	:
	<b>900</b>	Vertical bottom end
<b>MDBOX_HOS</b>		Define the horizontal left location of 2D arrayed box.
	<b>0</b>	Horizontal left end (default)
	:	:
	<b>720</b>	Horizontal right end
<b>MDBOX_VW</b>		Define the vertical size of 2D arrayed box.
	<b>0</b>	0 Line height (default)
	:	:
	<b>255</b>	255 Line height
<b>MDBOX_HW</b>		Define the horizontal size of 2D arrayed box.
	<b>0</b>	0 Pixel width (default)
	:	:
	<b>255</b>	510 Pixels width
<b>MDBOX_BNDEN</b>		Enable the boundary of 2D arrayed box.
	<b>0</b>	Disable the boundary (default)
	<b>1</b>	Enable the boundary
<b>MD_BNDRY_COLR</b>		Define the color of 2D arrayed box boundary
	<b>0</b>	0 % Black (default)

- 1 25% Gray
- 2 50% Gray
- 3 75% White

Define the displayed color for cursor cell and motion-detected region

- 0,1 75% White (default)
- 2,3 0% Black

- MDCUR\_HPOS Indicate the horizontal location of the cursor cell
- MDCUR\_VPOS Indicate the vertical location of the cursor cell
- MDBOX\_HCELL Indicate the number of columns in the 2D box
- MDBOX\_VCELL Indicate the number of rows in the 2D box

**Page E : 0xE00 ~ 0xEFE**

Address	[7]	[6]	[5]	[4]	[3]	[2]	[1]	[0]
0xE00							0	0

Reserved

Address	[7]	[6]	[5]	[4]	[3]	[2]	[1]	[0]
0xE40	LVDS_LP_SEL		LVDS_CP_SEL			LVDS_EN	LVDS_FAB_TEST	LVDS_LCD_TEST
0xE41	LVDS_SWAP_CH	LVDS_9BIT_DC	LVDS_NS_SEL	LVDS_DC_BAL	LVDS_BITPERPIXEL		LVDS_REV_DATA	LVDS_SEL_LD
0xE42			LVDS_REV_DCB	LVDS_DCB_POL		LVDS_MAP_SEL		
0xE43						LVDS_VOS_SEL	LVDS_I_SEL	

LVDS_LP_SEL		Default 0
LVDS_CP_SEL		Default 0
LVDS_EN	0	LVDS Disabled
	1	LVDS Enabled
LVDS_FAB_TEST	0	Normal Operation
	1	LVDS Test Mode
LVDS_LCD_TEST	0	Normal Operation
	1	LCD Panel Test Mode
LVDS_SWAP_CH	1	Swap LVDS channel 0 and 1
	0	Do not swap LVDS channel 0 and 1
LVDS_9BIT_DC	0	Select 7 cycle DC balance, as used in most National chip
	1	Select 9 cycle DC balance, as used in MAXIM chip
LVDS_NS_SEL	0	Output data mapping same as Maxim or THine LVDS interface protocol
	1	Output data mapping same as National interface protocol
LVDS_DC_BAL	1	DC Balance Enable
	0	DC Balance Disable
LVDS_BITPERPIXEL	0	6 bit data output
	1	8 bit data output
	2	10 bit data output
LVDS_REV_DATA	0	Normal data output format
	1	Reverse data output format
LVDS_SEL_LD		Load/Shift signal polarity selection
	0	Active low
	1	Active high
LVDS_REV_DCB	1	Reverse DC balance bit order
LVDS_DCB_POL	1	Reverse DC balance polarity
LVDS_MAP_SEL		Change the mapping location of DE, VSYNC and HSYNC signals
	000	{DE, VSYNC, HSYNC }
	001	{VSYNC, HSYNC, DE }
	010	{HSYNC, DE, VSYNC }
	100	{DE, HSYNC, VSYNC }
	101	{HSYNC, VSYNC, DE }
	110	{VSYNC, DE, HSYNC }

LVDS\_VOS\_SEL      LVDS Driver Voltage Offset Select

LVDS\_I\_SEL      LVDS Driver Output Swing Select

Address	[7]	[6]	[5]	[4]	[3]	[2]	[1]	[0]
0xEB0	PPLL_F[7:0]							
0xEB1	PPLL_OD			PPLL_R				
0xEB2	EXT_PCLK_SEL				PPLL_OE		PPLL_BP	

PPLL is controlled with the following equation

$$F_{OUT} = (F_{IN} * 2 * F) / (R * N_O)$$

With the following restriction:

- 2 MHz < F<sub>IN</sub> / R < 8 MHz
- 200 MHz < F<sub>OUT</sub> \* N<sub>O</sub> < 400 MHz
- 50 MHz < F<sub>OUT</sub> < 400 MHz

PPLL\_F      The F parameter in the equation  
 PPLL\_R      The R parameter in the equation  
 PPLL\_OD      OD of PLL, determines the N<sub>O</sub> in the equation

0	NOT ALLOWED
1	N <sub>O</sub> = 1
2	N <sub>O</sub> = 2
3	N <sub>O</sub> = 4

EXT\_PCLK\_SEL      Select the external PCLK, rather than using the internal PLL Clock

- 3'b1xx Force pclk to 0
- 3'b000 Select PPLL\_CLK
- 3'b010 Select PPLL\_CLK/2
- 3'b0x1 Select P\_EXT\_PCLK

PPLL\_OE      OE of PCLK PLL

PPLL\_BP      Bypass of PCLK PLL

Address	[7]	[6]	[5]	[4]	[3]	[2]	[1]	[0]
0xEB4	MPLL_F[7:0]							
0xEB5	MPLL_F[8]	MPLL_OD			MPLL_R			
0xEB6						EXT_MCLK_SEL	MPLL_OE	MPLL_BP

MPLL is controlled with the following equation

$$FOUT = (FIN * 2 * F) / (R * NO)$$

With the following restriction:

$$2 \text{ MHz} < FIN / R < 8 \text{ MHz}$$

$$200 \text{ MHz} < FOUT * NO < 400 \text{ MHz}$$

$$50 \text{ MHz} < FOUT < 400 \text{ MHz}$$

MPLL_F	The F parameter in the equation
MPLL_R	The R parameter in the equation
MPLL_OD	OD of PLL, determines the NO in the equation
	0 Not allowed
	1 NO = 1
	2 NO = 2
	3 NO = 4
EXT_MCLK_SEL	1 Select the external MCLK signal rather than from PLL
	0 Select the PLL output as MCLK
MPLL_OE	OE of MPLL
MPLL_BP	Bypass of MPLL

Address	[7]	[6]	[5]	[4]	[3]	[2]	[1]	[0]
0xEB8				SPLL_IREF	SPLL_CPX4		SPLL_LPX4	

SPLL_IREF	System clock PLL current control
	0 Lower current (Default)
	1 Higher current (30% more than setting to 0)
SPLL_CPX4	System clock PLL charge pump select
	0 1 uA
	1 5 uA (Default)
	2 10 uA
	3 15 uA
SPLL_LPX4	System clock PLL loop filter select
	0 80K Ohms
	1 40K Ohms (Default)
	2 30K Ohms
	3 20K Ohms

Address	[7]	[6]	[5]	[4]	[3]	[2]	[1]	[0]
0xEB9		SPLL_PD	MPLL_PD	PPLL_PD	DLL_DBG	SPLL_DBG	MPLL_DBG	PPLL_DBG

PPLL_PD	Power Down of PCLK PLL
MPLL_PD	Power Down of MPLL
SPLL_PD	Power Down of SPLL
xPLL_DBG	Reserved for internal test purpose only
DLL_DBG	Reserved for internal test purpose only

Address	[7]	[6]	[5]	[4]	[3]	[2]	[1]	[0]
0xEBA					AIGAIN1			
0xEBB	0	0	0	0	0	0	0	0
0xEBC	0	0	0	1	0	0	0	0
0xEBD	AIGAIN3				AIGAIN2			
0xEBE	AIGAIN5				AIGAIN4			

**AIGAIN** Select the amplifier's gain for each analog audio input AIN1 ~ AIN5.

0	0.25
1	0.31
2	0.38
3	0.44
4	0.50
5	0.63
6	0.75
7	0.88
8	1.00 (default)
9	1.25
10	1.50
11	1.75
12	2.00
13	2.25
14	2.50
15	2.75

Address	[7]	[6]	[5]	[4]	[3]	[2]	[1]	[0]
0xEC0		VDOX_422	MPPVDO_SEL	RGBOUT_EN	VDOY_H_PD	VDOY_L_PD	VDOS_PD	VDOX_PD
0xEC1	DAC1_GAIN				DAC0_GAIN			
0xEC2	DACR_GAIN				DACG_GAIN			
0xEC3	V_DAC_PD	V_DAC1_PD	V_DAC0_PD	RGB_DAC_PD	DACB_GAIN			
0xEC4	EXT_VADC	EXT_AADC	A_DAC_PD	A_ADC_PD	V_ADC_PD			

VDOX_PD	1	Set VDOX to 0
	0	Enable VDOX Output
VDOS_PD	1	Set VDOS to 0
	0	Enable VDOS Output
VDOY_L_PD	1	Set VDOY[7:0] to 0
	0	Enable VDOY[7:0] Output
VDOY_H_PD	1	Set VDOY[15:8] to 0
	0	Enable VDOY[15:8] Output
RGBOUT_EN	1	Enable RGB Output on PINs shared with LVDS
	0	Disable RGB Output on PINs shared with LVDS
MPPVDO_SEL	1	Set MPP PIN output as Digital B component
	0	Set MPP PIN output as VDOX[15:8]
VDOX_422	1	Select digital display output as 422 interlaced digital video output. The VS/HS/DE is through the VGA_VS / VGA_HS / VGA_DE pins. The Y component is through the MPP_VDO (VDOX[15:8]) pins. The UV component is through VDOX[7:0] pins.
	0	Select RGB output instead.
DACxx_GAIN		The video gain control for CVBS0/1 and RGB DACs.
xxx_PD	1	Power down the ADC / DACs to save power. This applies to V_DAC, V_DAC0, V_DAC1, A_DAC, RGB_DAC, A_ADC, V_ADC
EXT_AADC		Internal Testing feature
EXT_VADC		Internal Testing feature



Address	[7]	[6]	[5]	[4]	[3]	[2]	[1]	[0]
0xEC5					VGA_CLK_POL	VGA_DAC_CLK_POL	DAC0_CLK_POL	DAC1_CLK_POL
0xEC8	0			0			A_DAC_BIAS_SEL	

VGA_CLK_POL	Change the VGA output clock polarity
VGA_DAC_CLK_POL	Change the polarity of the clock used by the VGA DACs
DAC0_CLK_POL	Change the polarity of the clock used by CVBS0 DAC
DAC1_CLK_POL	Change the polarity of the clock used by CVBS1 DAC
A_DAC_BIAS_SEL	Bias Selection
0	Use AVDD33 as the reference voltage
1	Use bandgap voltage as the reference

## AC Timing

TABLE 22. CASCADE CLOCK TIMING PARAMETERS

PARAMETER	SYMBOL	MIN	TYP	MAX	UNITS
Setup from VDI <sub>X</sub> to CLKI <sub>X</sub>	1a	3			ns
Hold from CLKI <sub>X</sub> to VDI <sub>X</sub>	1b	3			ns
Setup from VDI <sub>Y</sub> to CLKI <sub>Y</sub>	2a	3			ns
Hold from CLKI <sub>Y</sub> to VDI <sub>Y</sub>	2b	3			ns
Setup from VDI <sub>S</sub> to CLKI <sub>S</sub>	3a	3			ns
Hold from CLKI <sub>S</sub> to VDI <sub>S</sub>	3b	3			ns

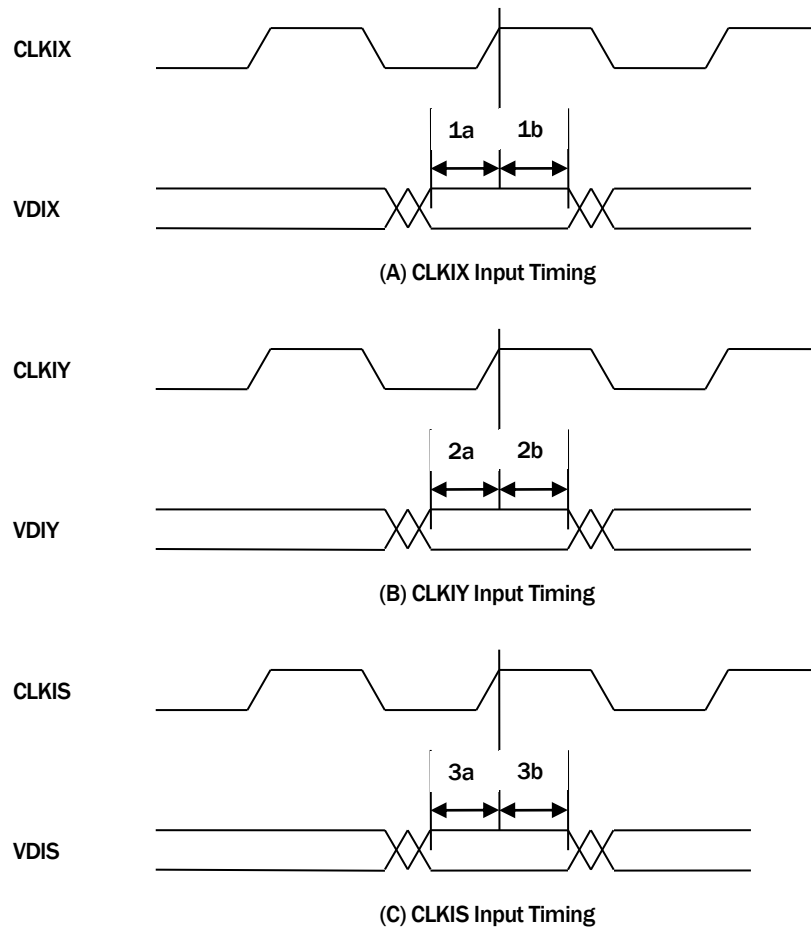
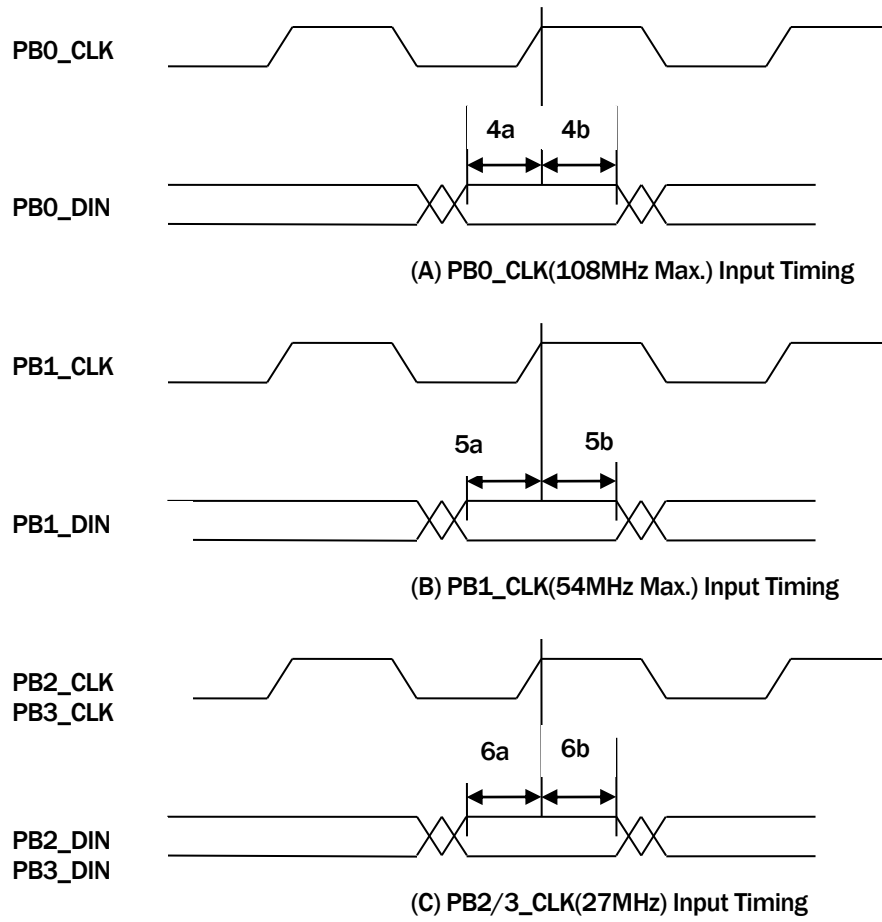

FIGURE 59. CASCADE INTERFACE TIMING DIAGRAM

TABLE 23. PLAYBACK INTERFACE TIMING PARAMETERS

PARAMETER	SYMBOL	MIN	TYP	MAX	UNITS
Setup from PBO_DIN to PBO_CLK	4a	3			ns
Hold from PBO_CLK to PBO_DIN	4b	3			ns
Setup from PB1_DIN to PB1_CLK	5a	3			ns
Hold from PB1_CLK to PB1_DIN	5b	3			ns
Setup from PB2/3_DIN to PB2/3_CLK	6a	3			ns
Hold from PB2/3_CLK to PB2/3_DIN	6b	3			ns



**FIGURE 60. PLAYBACK INTERFACE TIMING DIAGRAM**

TABLE 24. DIGITAL VIDEO OUTPUT TIMING PARAMETERS

PARAMETER	SYMBOL	MIN	TYP	MAX	UNITS
Hold from CLKOX to VDOX	7a	2			ns
Delay from CLKOX to VDOX	7b			7.2	ns
Hold from CLKOY to VDOY	8a	2			
Delay from CLKOY to VDOY	8b			7.2	
Hold from CLKOS to VDOS	9a	5			
Delay from CLKOS to VDOS	9b			31.8	

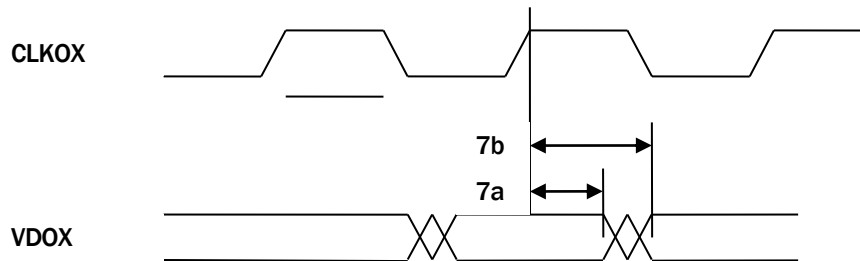

(A) CLKOX(108MHz Max.) Input Timing

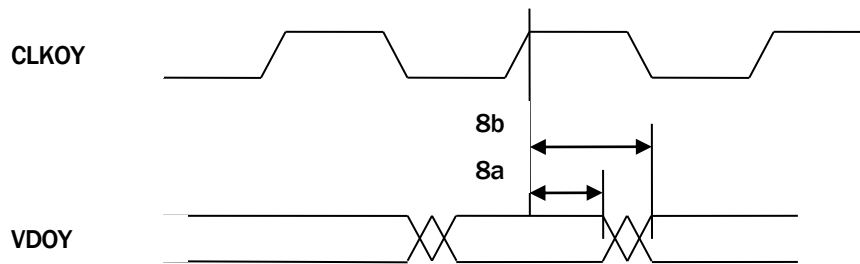

(B) CLKOY(108MHz Max.) Input Timing

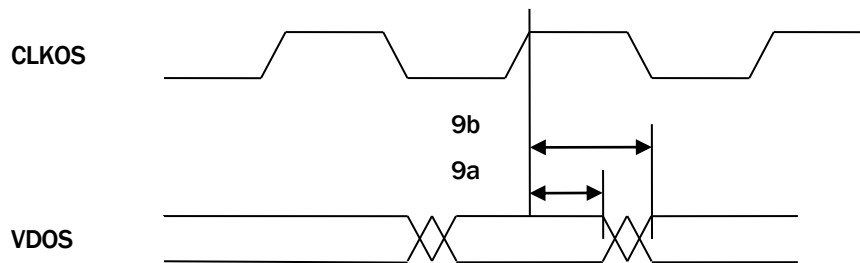

(C) CLKOS(27MHz) Input Timing

FIGURE 61. DIGITAL VIDEO OUTPUT TIMING DIAGRAM

## Parametric Information

### AC/DC Electrical Parameters

TABLE 25. CHARACTERISTICS

PARAMETER	SYMBOL	MIN (NOTE 1)	TYP	MAX (NOTE 1)	UNITS
<b>POWER SUPPLY</b>					
Power Supply – Digital I/O	V <sub>VDDO</sub>	2.97	3.3	3.63	V
	I <sub>VDDO</sub>		120		mA
	P <sub>VDDO</sub>		396		mW
Power Supply – LVDS I/O, SPLL	V <sub>LVDDO</sub> , V <sub>VDDSPLL</sub>	2.97	3.3	3.63	V
	I <sub>LVDDO</sub> , I <sub>VDDSPLL</sub>		5		mA
	P <sub>LVDDO</sub> , P <sub>VDDSPLL</sub>		16.5		mW
Power Supply – SSTL I/O	V <sub>VDDPSSTL</sub>	2.3	2.5	2.7	V
	I <sub>VDDPSSTL</sub>		130		mA
	P <sub>VDDPSSTL</sub>		325		mW
Power Supply – Analog CVBS A/D	V <sub>VDDVADC</sub>	2.97	3.3	3.63	V
	I <sub>VDDVADC</sub>		60		mA
	P <sub>VDDVADC</sub>		198		mW
Power Supply – Analog CVBS D/A	V <sub>VDDVDAC</sub> , V <sub>VDDAVDAC</sub>	2.97	3.3	3.63	V
	I <sub>VDDVDAC</sub>		80		mA
	P <sub>VDDVDAC</sub>		264		mW
Power Supply – Analog RGB D/A	V <sub>VDDDRGB</sub> , V <sub>VDDARGB</sub>	2.97	3.3	3.63	V
	I <sub>VDDRGB</sub>		60		mA
	P <sub>VDDRGB</sub>		198		mW
Power Supply – Audio Decoder A/D, D/A	V <sub>VDDAACD</sub> , V <sub>VDDADAC</sub>	2.97	3.3	3.63	V
	I <sub>VDDAACD</sub> , I <sub>VDDADAC</sub>		20		mA
	P <sub>VDDAACD</sub> , P <sub>VDDADAC</sub>		66		mW
Power Supply – DLL, SSTL Core, Digital Core, MPLL, PPLL	V <sub>VDDDLL</sub> , V <sub>VDDSSSTL</sub> , V <sub>VDDI</sub> , V <sub>VDDMPLL</sub> , V <sub>VDDPPLL</sub>	1.08	1.2	1.32	V
	I <sub>VDD</sub>		320		mA
	P <sub>VDD</sub>		384		mW
Voltage Reference for SSTL PAD	V <sub>VREFSSTL</sub>		1.25		V
	I <sub>VREFSSTL</sub>		2		mA
	P <sub>VREFSSTL</sub>		2.5		mW
Ambient Operating Temperature	T <sub>A</sub>	-40		+85	°C
<b>DIGITAL INPUTS</b>					
Input High Voltage (TTL)	V <sub>IH</sub>	2.0		3.6	V
Input Low Voltage (TTL)	V <sub>IL</sub>	-0.3		0.8	V

PARAMETER	SYMBOL	MIN (NOTE 1)	TYP	MAX (NOTE 1)	UNITS
Input High Current ( $V_{IN} = V_{DD}$ )	$I_{IH}$			10	$\mu A$
Input Low Current ( $V_{IN} = V_{SS}$ )	$I_{IL}$			-10	$\mu A$
Input Capacitance ( $f = 1 \text{ MHz}$ , $V_{IN} = 2.4 \text{ V}$ )	$C_{IN}$		6		pF
<b>DIGITAL OUTPUTS</b>					
Output High Voltage ( $I_{OH} = -4\text{mA}$ )	$V_{OH}$	2.4		VDD33	V
Output Low Voltage ( $I_{OL} = 4\text{mA}$ )	$V_{OL}$			0.4	V
3-State Current	$I_{OZ}$			10	$\mu A$
Output Capacitance	$C_O$		6		pF
<b>ANALOG INPUT</b>					
Analog Pin Input Voltage at VIN1A, VIN1B, VIN2A, VIN2B, VIN3, VIN3B, VIN4A, VIN4B, AIN1, AIN2, AIN3, AIN4, AIN5 Input Range (AC Coupling Required)	$V_i$	0	1.0	2.0	Vpp
Analog Pin Input Capacitance	$C_A$		6		pF
<b>ADCS</b>					
ADC Resolution	ADCR		10		bits
ADC Integral Non-Linearity	AINL		$\pm 1$		LSB
ADC Differential Non-Linearity	ADNL		$\pm 1$		LSB
ADC Clock Rate	$f_{ADC}$	24	27	30	MHz
<b>HORIZONTAL PLL</b>					
Line Frequency (50Hz)	$f_{LN}$		15.625		KHz
Line Frequency (60Hz)	$f_{LN}$		15.734		KHz
Static Deviation	$\Delta f_H$			6.2	%
<b>SUBCARRIER PLL</b>					
Subcarrier Frequency (NTSC-M)	$f_{SC}$		3579545		Hz
Subcarrier Frequency (PAL-BDGI)	$f_{SC}$		4433619		Hz
Subcarrier Frequency (PAL-M)	$f_{SC}$		3575612		Hz
Subcarrier Frequency (PAL-N)	$f_{SC}$		3582056		Hz
Lock In Range	$\Delta f_H$	$\pm 450$			Hz
<b>CRYSTAL SPEC</b>					
Nominal Frequency (Fundamental)			27		MHz
Deviation				$\pm 50$	ppm
Temperature Range	$T_a$	-40		85	$^{\circ}C$
Load Capacitance	CL		20		pF
Series Resistor	RS		80		Ohm

NOTE:

1. Compliance to datasheet limits is assured by one or more methods: production test, characterization and/or design.

# Package Outline Drawing

V352.27x27

352 PLASTIC BALL GRID ARRAY PACKAGE

Rev 0, 3/11

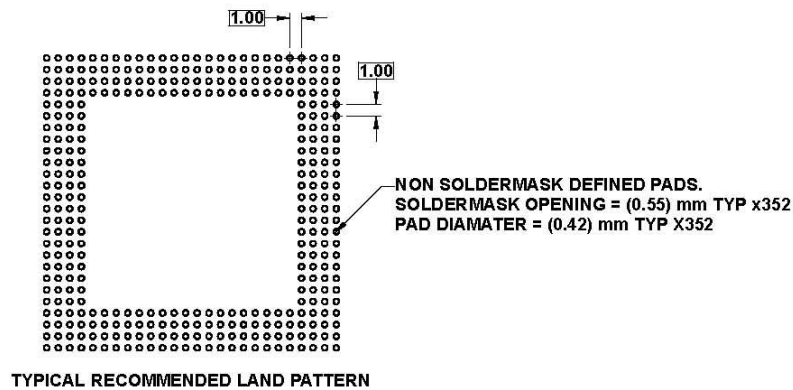
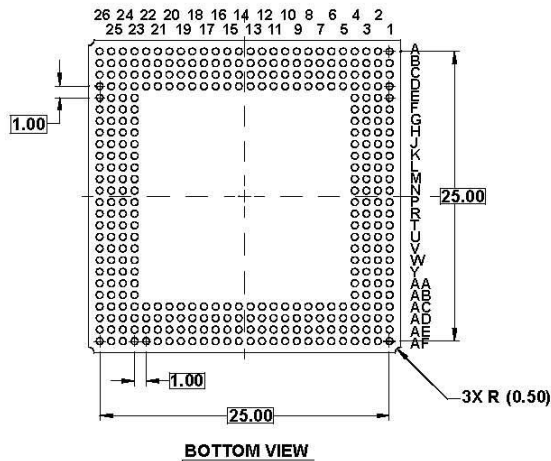
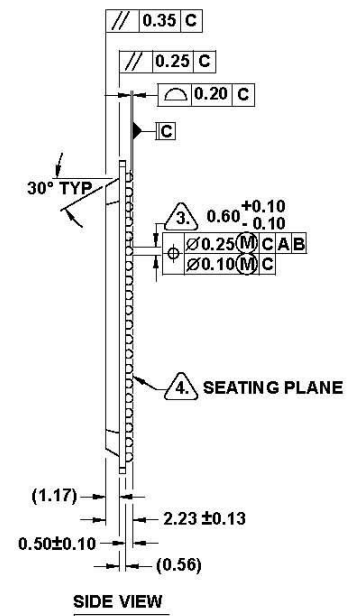
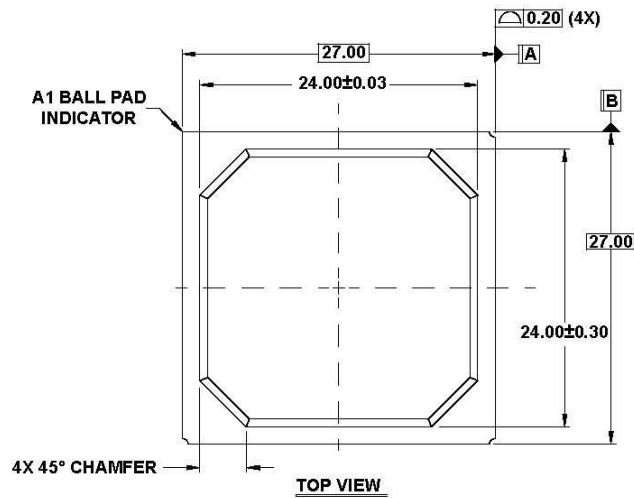

**NOTES:**

1. All dimensions and tolerances conform to ASME Y14.5-1994.
2. Dimensions are in millimeters.
3. Dimension is measured at the maximum solder ball diameter, parallel to primary datum C.
4. Primary datum C and seating plane are defined by the spherical crowns of the solder balls.
5. This drawing confirms to the JEDEC registered outline MS-034 variation AAL-1.
6. Dimensions in ( ) are for reference only

## Life Support Policy

These products are not authorized for use as critical components in life support devices or systems.

## Revision History

REVISION	DATE	CHANGES NOTE
FN7743.0	August 17, 2012	Initial release.

© Copyright Intersil Americas LLC 2012. All Rights Reserved.

All trademarks and registered trademarks are the property of their respective owners.

For additional products, see [www.intersil.com/product\\_tree](http://www.intersil.com/product_tree)

Intersil products are manufactured, assembled and tested utilizing ISO9001 quality systems as noted in the quality certifications found at <http://www.intersil.com/en/support/qualandreliability.html>

---

*Intersil products are sold by description only. Intersil may modify the circuit design and/or specifications of products at any time without notice, provided that such modification does not, in Intersil's sole judgment, affect the form, fit or function of the product. Accordingly, the reader is cautioned to verify that datasheets are current before placing orders. Information furnished by Intersil is believed to be accurate and reliable. However, no responsibility is assumed by Intersil or its subsidiaries for its use; nor for any infringements of patents or other rights of third parties which may result from its use. No license is granted by implication or otherwise under any patent or patent rights of Intersil or its subsidiaries.*

---

For information regarding Intersil Corporation and its products, see <http://www.intersil.com>



Компания «Life Electronics» занимается поставками электронных компонентов импортного и отечественного производства от производителей и со складов крупных дистрибьюторов Европы, Америки и Азии.

С конца 2013 года компания активно расширяет линейку поставок компонентов по направлению коаксиальный кабель, кварцевые генераторы и конденсаторы (керамические, пленочные, электролитические), за счёт заключения дистрибьюторских договоров

Мы предлагаем:

- Конкурентоспособные цены и скидки постоянным клиентам.
- Специальные условия для постоянных клиентов.
- Подбор аналогов.
- Поставку компонентов в любых объемах, удовлетворяющих вашим потребностям.
- Приемлемые сроки поставки, возможна ускоренная поставка.
- Доставку товара в любую точку России и стран СНГ.
- Комплексную поставку.
- Работу по проектам и поставку образцов.
- Формирование склада под заказчика.
- Сертификаты соответствия на поставляемую продукцию (по желанию клиента).
- Тестирование поставляемой продукции.
- Поставку компонентов, требующих военную и космическую приемку.
- Входной контроль качества.
- Наличие сертификата ISO.

В составе нашей компании организован Конструкторский отдел, призванный помогать разработчикам, и инженерам.

Конструкторский отдел помогает осуществить:

- Регистрацию проекта у производителя компонентов.
- Техническую поддержку проекта.
- Защиту от снятия компонента с производства.
- Оценку стоимости проекта по компонентам.
- Изготовление тестовой платы монтаж и пусконаладочные работы.



Тел: +7 (812) 336 43 04 (многоканальный)  
Email: [org@lifeelectronics.ru](mailto:org@lifeelectronics.ru)