

Data	List No.	VS0001	VS0002
Max. Rating:		6.3A. 120/240V.	6.3A. 120/240V.
Insulation Resistance:		>10 ⁶ MΩ	>10 ⁶ MΩ
Termination:		2.8 series tabs/solder tags.	2.8 series tabs/solder tags.
Temperature Range:		-20 to +85°C	-20 to +85°C
Materials: Mouldings:		Glass Filled Nylon. Flammability Rating UL94V-1	Glass Filled Nylon. Flammability Rating UL94V-1
Tags:		Brass, Silver Plated.	Brass, Silver Plated.
Contacts:		Copper Silver Alloy.	Copper Silver Alloy.
Approvals:			
Variants:		Other markings, details on request.	Other markings, details on request.

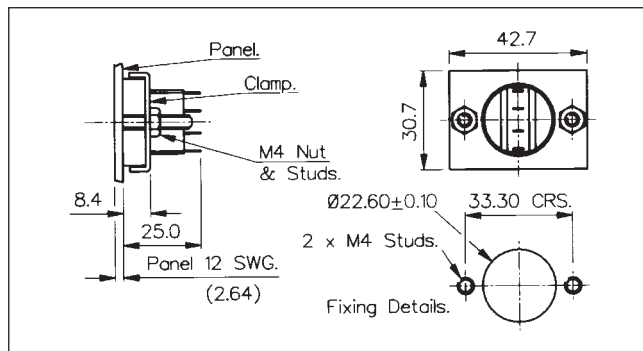

Data	List No.	MP0027	MP0038	MP0025
Terminations:		Solder tags.	Solder tags.	Solder tags.
Switching:		S.P.C.O. Momentary Action (Microswitch).	S.P.C.O. Momentary Action (Microswitch).	S.P.C.O. Momentary Action (Microswitch).
Max. Rating:		5A. 250V. a.c.	5A. 250V. a.c.	5A. 250V. a.c.
Insulation Resistance:		>10 ³ MΩ.	>10 ³ MΩ.	>10 ³ MΩ.
Contact Resistance:		< 10mΩ.	< 10mΩ.	< 10mΩ.
Dielectric Strength:		>2.0kV. a.c.	>2.0kV. a.c.	>2.0kV. a.c.
Operating Temp. Range:		-20°C to + 70°C.	-20°C to + 70°C.	-20°C to + 70°C.
Sealing (Front of panel only):			Protection Classification: IP66 EN60529 1992. (Micro switch not sealed).	
Materials:	Mouldings:	Glass Filled Nylon.	Glass Filled Nylon.	Glass Filled Nylon.
	Tags/ Terminations:	Brass, Tin Plated.	Brass, Tin Plated.	Brass, Tin Plated.
	Switch Body & Button:	Stainless Steel.	Stainless Steel.	Stainless Steel.
Contacts:		Fine Silver.	Fine Silver.	Fine Silver.
Variants:		Non-Rotating Button, details on request.	Non-Rotating Button, details on request.	Non-Rotating Button, details on request.

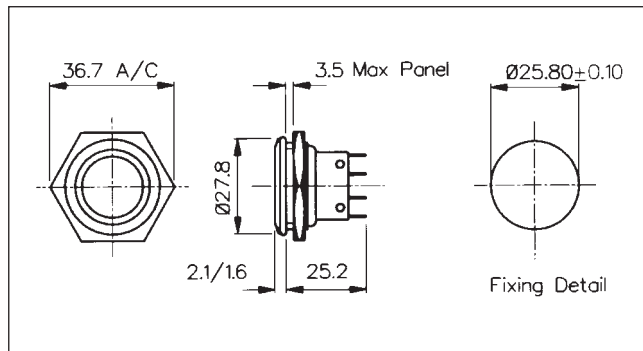
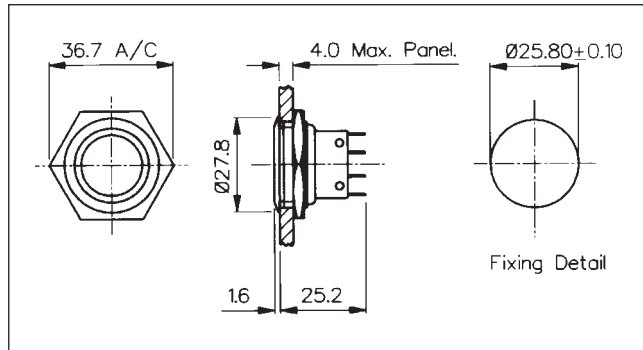
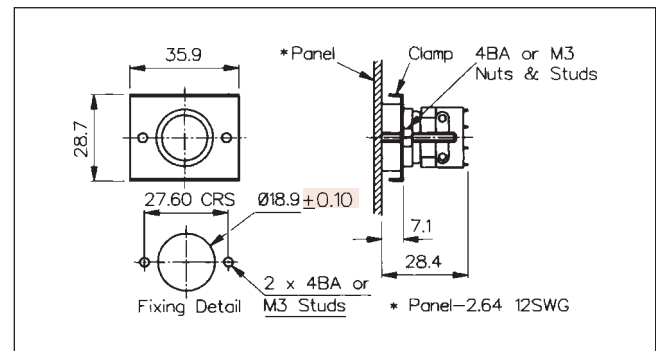
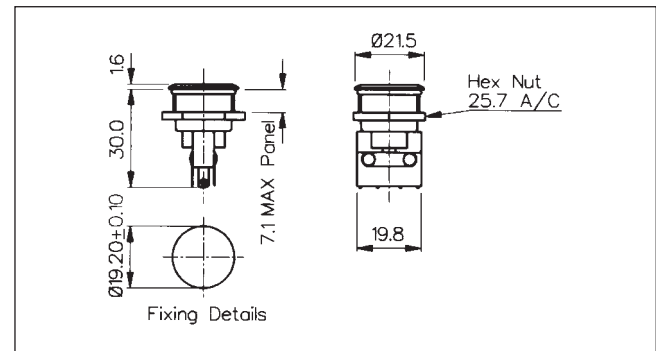
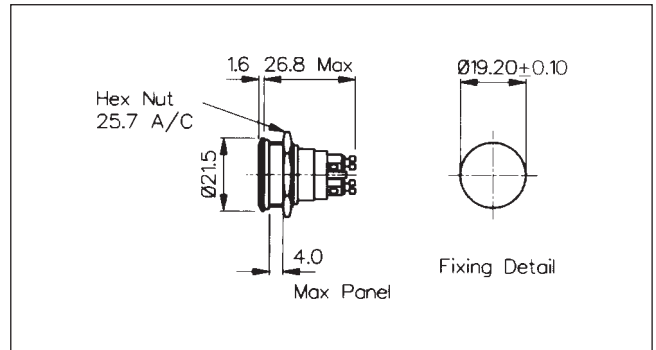

Data	List No.	MP0037	MP0031	MP0034
Terminations:		Screw terminals.	Solder tags.	Solder tags.
Switching:		S.P. Push to make. Slow momentary action.	S.P.C.O. Momentary Action (Microswitch).	S.P.C.O. Momentary Action (Microswitch).
Max. Rating:		1A. 50V.	5A. 250V. a.c.	5A. 250V. a.c.
Insulation Resistance:		>10 ⁵ MΩ.	>10 ³ MΩ.	>10 ³ MΩ.
Contact Resistance:		< 10mΩ.	< 10mΩ.	< 10mΩ.
Dielectric Strength:		>1.0kV. a.c.	>2.0kV. a.c.	>2.0kV. a.c.
Operating Temp. Range:		-20°C to +70°C.	-20°C to +70°C.	-20°C to +70°C.
Sealing (Front panel only):		Protection Classification: IP66 EN60529 1992. (Terminals not sealed).	Protection Classification: IP66 EN60529 1992. (Micro switch not sealed).	
Materials:	Mouldings:	Glass Filled Nylon.	Glass Filled Nylon.	Glass Filled Nylon.
	Tags/Terminals:	Brass, Silver Plated.	Brass, Tin Plated.	Brass, Tin Plated.
	Switch Body & Button:	Stainless Steel.	Stainless Steel.	Stainless Steel.
Contacts/Terms:		Brass, Silver Plated, Silver	Fine Silver.	Fine Silver.
Variants:			Non-Rotating Button, details on request.	Non-Rotating Button, details on request.

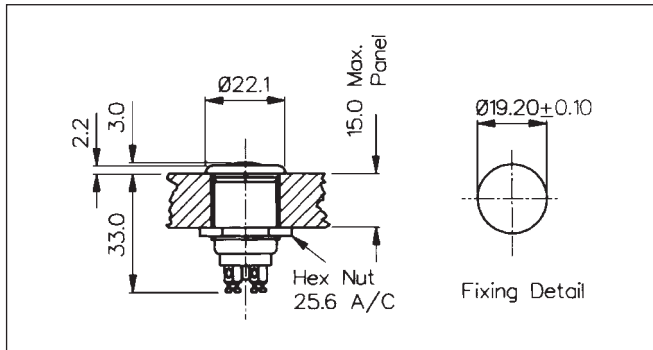

SWITCHES



Data	List No.	MP0013, MP0033		
Terminations:		Screw terminals.		
Switching:		S.P. Push to Make. Slow Momentary Action.		
Max. Rating:		1A. 50V.		
Insulation Resistance:		>10 ⁴ MΩ.		
Contact Resistance:		<15 mΩ.		
Dielectric Strength:		>2.5kV. a.c.		
Operating Temp. Range:		-20°C to + 85°C.		
Sealing:		MP0033 only - internally sealed against ingress of water and dust.		
Materials:	Mouldings:	Glass Filled Nylon.		
	Tags/Terminals:	Brass, Silver Plated.		
	Switch Body & Button:	Body: Brass, Chrome Plated. Button: Stainless Steel.		
Contacts/Terms:		Copper, Silver Plated.		
Variants:				

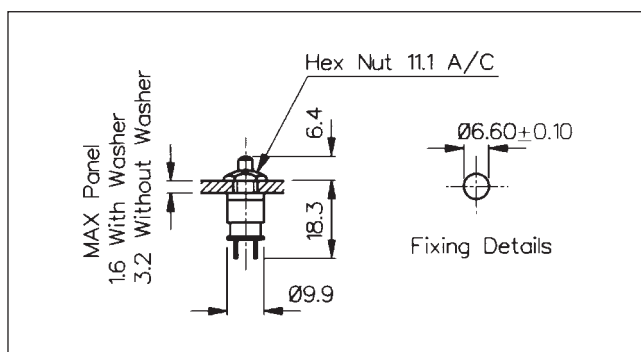
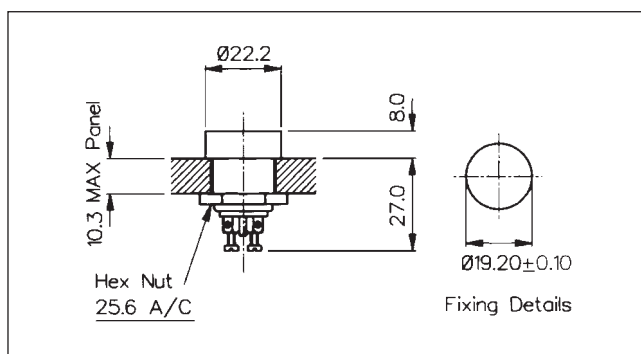
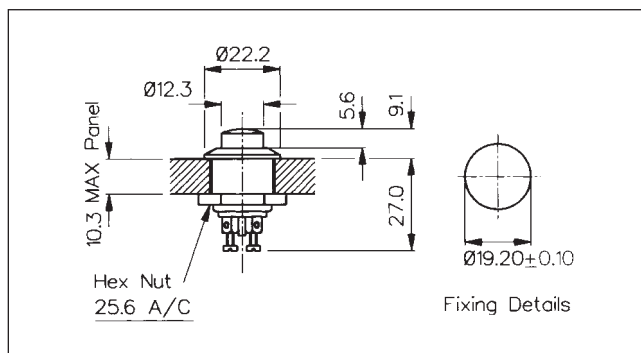

Data	List No.	MP0012/Colour	MP0012/1/Colour	MP0016
Terminations:		Screw terminals.	Screw terminals.	Solder tags.
Switching:		S.P. Push to Make. Slow Momentary Action.	S.P. Push to Make. Slow Momentary Action.	S.P. Push to Make. Slow Momentary Action.
Max. Rating:		0.25A. 250V. a.c., 1A. 110V.a.c., 2A. 12V. a.c./d.c.	0.25A. 250V. a.c., 1A. 110V.a.c., 2A. 12V. a.c./d.c.	1A. 28V. a.c/d.c. (non-inductive).
Contact Resistance:		<15 mΩ.	<15 mΩ.	<15 mΩ.
Insulation Resistance:		>10 ⁴ MΩ.	>10 ⁴ MΩ.	>10 ⁴ MΩ.
Dielectric Strength:		>2.5kV. a.c.	>2.5kV. a.c.	>2kV. a.c.
Operating Temp. Range:		-20°C to + 85°C.	-20°C to + 85°C.	-20°C to + 85°C.
Materials:	Moulding:	Glass Filled Nylon.	Glass Filled Nylon.	Glass Filled Nylon.
	Body:	Brass, Chrome Plated.	Brass, Chrome Plated.	Brass, Nickel Plated.
Contacts/Terms:		Brass, Silver Plated.	Brass, Silver Plated.	Brass, Silver Plated.
Variants:		Button Colour: Standard: /BK - black. (/RD - red details on request).	Button Colour: Standard: /BK - black. (/RD - red details on request).	Button Colour: Standard: black. (/RD - red details on request).



Data	List No.	MP0022/Colour	SX0904/Colour	SM0357, SM0365
Terminations:		Solder tags.	Solder tags.	Solder tags.
Switching:		S.P. Push to Make. Slow Momentary Action.	S.P.C.O. Momentary Action (Microswitch).	SM0357 S.P.C.O. 2 pairs contacts. SM0365 S.P.M.B. push to make. 1 pair contacts.
Max. Rating:		0.25A. 250V. a.c., 0.5A. 110V. a.c., 1A. 0.1 to 28V. a.c./d.c	5A. 250V. a.c.	SM0357 2A. 250V. a.c. SM0365 3A. 250V. a.c
Contact Resistance:		<15 mΩ.	< 10mΩ.	<10 mΩ.
Insulation Resistance:		>10 ⁴ MΩ.	>10 ³ MΩ	>10 ³ MΩ.
Dielectric Strength:		>2.5kV. a.c.	>2.0kV. a.c.	>4.5kV. a.c.
Operating Temp. Range:		-20°C to + 70°C.	-20°C to + 70°C	-20°C to + 70°C.
Sealing:			Protection Classification: IP66 BS5490 : 1992 (Microswitch not sealed).	
Materials:	Mouldings: Tags: Body:	Nylon. Brass, Silver Plated. Nylon.	Glass Filled Nylon. Brass, Tin Plated. Black anodised aluminium.	Phenolic. Brass, Silver Plated. Steel, Zinc Plated.
Contacts:		Nylon. Brass, Silver Plated.	Black anodised aluminium. Fine Silver.	Brass, Silver Plated.
Variants:		Button Colours: Standard: /BK - black (/WH - white details on request). MP0022/TERM - Screw terminals (to agreed orders)	Button Colours: Standard: /BK - black (/RD - red /GN - green details on request). /28 (2.8 mm tabs) to agreed orders.	Screw Terminals add /TERM to List No. (Not SM0357) /63 (6.3mm tabs) to agreed orders.

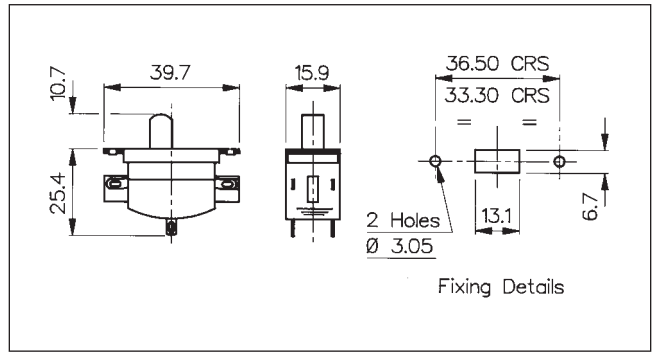
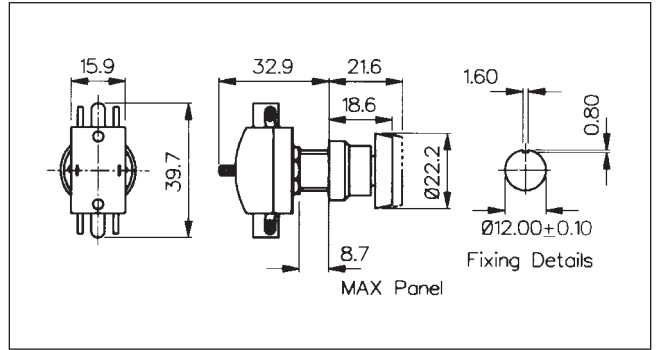

Data	List No.	SM0446/2/INS/RD	SM0596/2
Terminations:		Solder tags.	Solder tags.
Switching:		D.P.C.O. Quick Make /Break. 3 pairs of contacts.	D.P.C.O. Quick Make /Break. 3 pairs of contacts.
Max. Rating:		2A. 250V. a.c.	2A. 250V. a.c.
Contact Resistance:		<10 mΩ.	<10 mΩ.
Insulation Resistance:		>10 ³ MΩ.	>10 ³ MΩ.
Dielectric Strength:		>3.5kV. a.c.	>3.5kV. a.c.
Operating Temp. Range:		-20°C to + 70°C.	-20°C to + 70°C.
Materials:		Mouldings: Body: Phenolic. Button/Ring: Nylon (Red) Tags: Copper, Silver Plated.	Mouldings: Phenolic. Tags: Copper, Silver Plated.
Contacts:		Copper Silver Alloy.	Copper Silver Alloy.
Variants:		SM0446/2 - metal locking ring front of panel.	

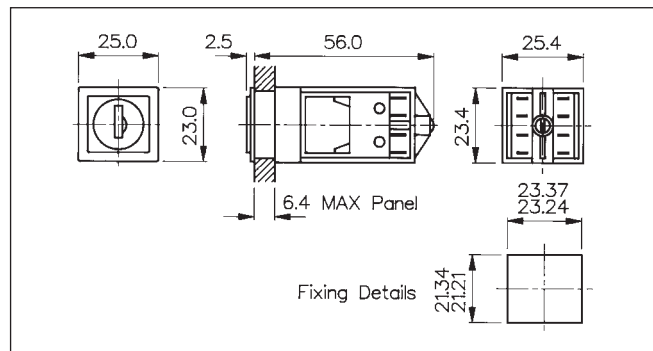
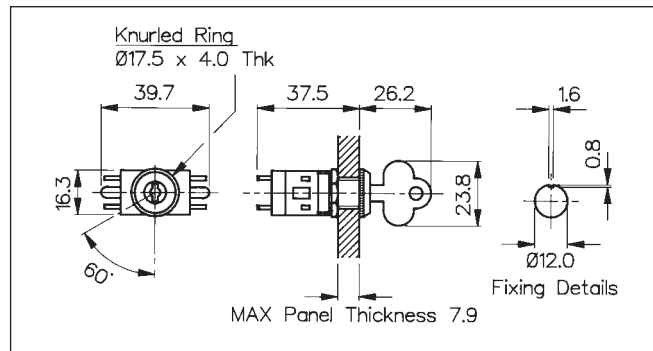
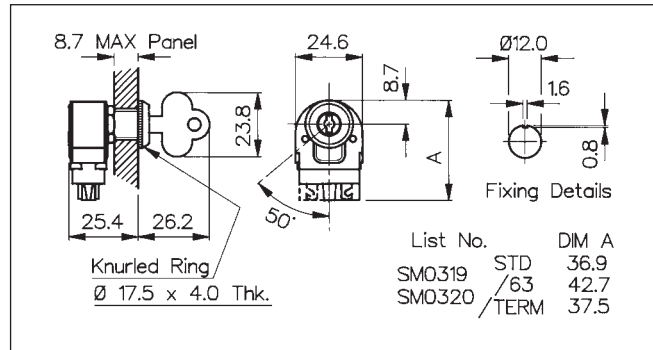

Data	List No.	SM0319, SM0320	SM0324/2	SX0686
Terminations:		Solder tags.	Solder tags.	Solder tags.
Switching:		SM0319 S.P.M.B. Quick Make /Break. SM0320 S.P.C.O. Quick Make /Break. Key removable in anti-clockwise position.	D.P.C.O. (Quick Make/Break). Key removable in anti-clockwise position.	D.P.C.O.
Max. Rating:		SM0319 3A. 250V. a.c. SM0320 2A. 250V. a.c.	2A. 250V. a.c.	5A. 250V. a.c. (non inductive).
Contact Resistance:		<10 mΩ.	<10 mΩ.	<10 mΩ.
Insulation Resistance:		>10 ³ MΩ.	>10 ³ MΩ	>10 ³ MΩ.
Dielectric Strength:		>4.5kV. a.c.	>3.5kV. a.c.	>4kV. a.c.
Operating Temp. Range:		-20°C to + 70°C.	-20°C to + 70°C.	-20°C to + 70°C.
Materials:		Mouldings: Phenolic. Tags: Brass, Silver Plated.	Mouldings: Phenolic. Tags: Copper, Silver Plated.	Mouldings: Glass Filled Nylon. Tags: Brass, Tin Plated.
Contacts:		Brass, Silver Plated.	Copper Silver Alloy.	Fine Silver.
Variants:		add /TERM (Screw Terminals), (Not SM0320)/63 (6.3mm tab) to List No. Key removable in both positions add /D to List No. (Not SM0320)	Key removable in both positions add /D to List No.	2 position 90° key rotation. Key Switches incorporating 5 tumbler cylinders. Supplied with 2 keys. Keys removable anti-clockwise position. SX0686/D key removable both positions. SX0686/SL Biased to anti-clockwise position. SX0686 Identical keys (spares available).
Keys:		Supplied with 1 key (spare keys order P.No. 6083/C).	Supplied with 1 key (spare keys order P.No. 6083/C).	

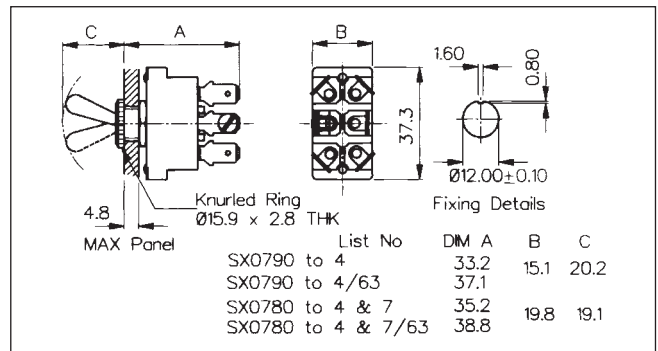
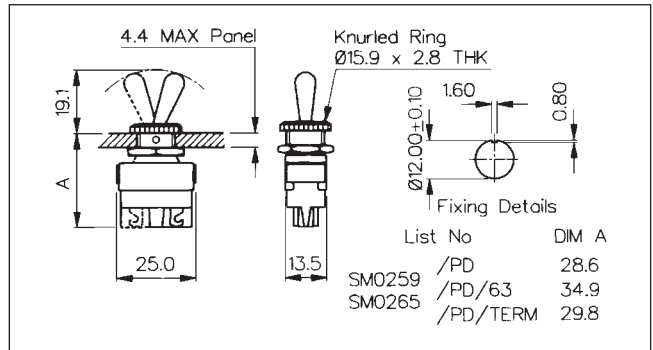

Single Pole List No.	Double Pole List No.	Description	1	2	3
SX0790	SX0780	Change-over. Centre-off.	ON	OFF	ON
SX0791	-	Change-over. Centre-off. One position biased off.	ON	OFF	ON
SX0792	SX0782	Change-over. Centre-off. Two positions biased off.	ON	OFF	ON
SX0793	SX0783	Change-over. Two positions only	ON	-	ON
SX0794	SX0784	ON/OFF Two positions only	OFF	-	ON
-	SX0787	Change-over. Two positions only, biased to one position.	ON	-	ON



Data	List No.	SM0259/PD, SM0265/PD	SX0780, SX0790 Series
Terminations:		Solder tags.	Screw terminals.
Switching:		SM0259/PD S.P.M.B. 1 pair of contacts. (Quick Make/Break). SM0265/PD S.P.C.O. 2 pairs of contacts. (Quick Make/Break).	See table for types. Slow Make, Slow Break.
Max. Rating:		SM0259/PD 3A. 250V. a.c. SM0265/PD 2A. 250V. a.c.	10A. 250V. a.c. 10A. 0-28V. d.c. (non-reactive circuits).
Contact Resistance:		<10 mΩ.	<10 mΩ.
Insulation Resistance:		>10 ³ MΩ.	>10 ³ MΩ.
Dielectric Strength:		>4.5kV. a.c.	>2.5kV. a.c.
Operating Temp. Range:		-20°C to +70°C.	-20°C to +85°C.
Materials:		Mouldings: Phenolic. Tags: Brass, Silver Plated.	Mouldings: Glass filled Polyester Terms: Brass, Silver Plated.
Contacts:		Brass, Silver Plated.	Copper with Silver face.
Variants:		For Screw Terminals add /TERM to List No. (Not SM0265/PD) For 6.3mm tab (to agreed orders) add /63 to List No.	For 6.3 series tabs (to agreed orders) add /63 to List No. (Not SX0791)
Accessories:		SX0550, PNo. 5943/D1 (See Page 192). NX1030 & /B (See Page 192).	

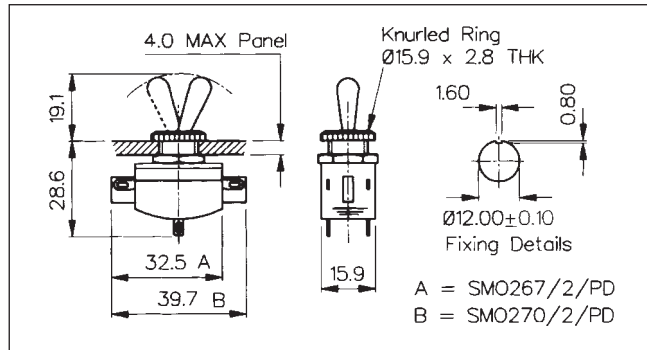

S
W
I
T
C
H
E
S



Data	List No.	SM0267/2/PD, SM0270/2/PD		
Terminations:		Solder tags.		
Switching:		SM0267/2/PD - D.P.M.B. 2 pairs of contacts. SM0270/2/PD - D.P.C.O. 3 pairs of contacts. (Quick Make/Break).		
Max. Rating:		2A 250V a.c.		
Contact Resistance:		<10 mΩ.		
Insulation Resistance:		>10 ³ MΩ.		
Dielectric Strength:		>3.5kV. a.c.		
Operating Temp. Range:		-20°C to +70°C.		
Materials:		Mouldings: Phenolic. Tags: Copper Silver Plated.		
Contacts:		Copper Silver Alloy.		
Accessories:		SX0550, P.No. 5943/D1 (see page 192). NX1030, & /B (see page 192).		

Switch Boots & Plates

SWITCHES

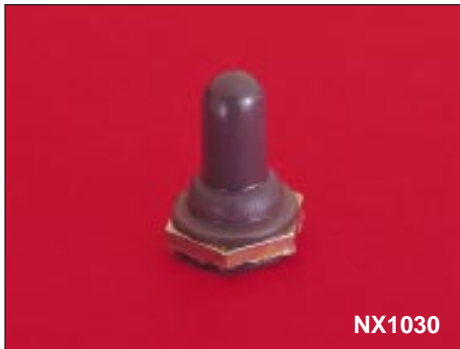

Data	List No.	SX0550, SX0550/Brass	P.No.5943/D1	NX1030, NX1030/B
		Water and dust resistant Black PVC cover for use with all Bulgin /PD switches.	Washer to enable plain round holes to be used in place in normal keyed fixing.	NX1030 Completely covers toggle. NX1030/B Switch toggle protrudes.
Thread:		$15/32$ " x 32 TPI Whit Form, BS84.		$15/32$ " - 32NS - 2B
Operating Temperature:		0° to +60°C.		-70° to +205°C.
Material	Boot:	Black PVC.	Brass, Nickel Plated.	Silicone rubber.
	Insert:	Glass Filled Nylon. SX0550/Brass: Brass, Nickel Plated.		Brass, Nickel Plated.

A full range of Toggle, Rocker & Circuit Breaker Switch Boots & Covers are available from our APM Hexseal Range. See page 194.

Mouser Electronics

Authorized Distributor

Click to View Pricing, Inventory, Delivery & Lifecycle Information:

[Bulgin:](#)

[SM0319/D](#) [SM0319](#) [SM0320/D](#) [SM0319/63](#) [SM0320](#) [SM0324/2](#)

Компания «Life Electronics» занимается поставками электронных компонентов импортного и отечественного производства от производителей и со складов крупных дистрибьюторов Европы, Америки и Азии.

С конца 2013 года компания активно расширяет линейку поставок компонентов по направлению коаксиальный кабель, кварцевые генераторы и конденсаторы (керамические, пленочные, электролитические), за счёт заключения дистрибьюторских договоров

Мы предлагаем:

- Конкурентоспособные цены и скидки постоянным клиентам.
- Специальные условия для постоянных клиентов.
- Подбор аналогов.
- Поставку компонентов в любых объемах, удовлетворяющих вашим потребностям.
- Приемлемые сроки поставки, возможна ускоренная поставка.
- Доставку товара в любую точку России и стран СНГ.
- Комплексную поставку.
- Работу по проектам и поставку образцов.
- Формирование склада под заказчика.
- Сертификаты соответствия на поставляемую продукцию (по желанию клиента).
- Тестирование поставляемой продукции.
- Поставку компонентов, требующих военную и космическую приемку.
- Входной контроль качества.
- Наличие сертификата ISO.

В составе нашей компании организован Конструкторский отдел, призванный помогать разработчикам, и инженерам.

Конструкторский отдел помогает осуществить:

- Регистрацию проекта у производителя компонентов.
- Техническую поддержку проекта.
- Защиту от снятия компонента с производства.
- Оценку стоимости проекта по компонентам.
- Изготовление тестовой платы монтаж и пусконаладочные работы.



Тел: +7 (812) 336 43 04 (многоканальный)

Email: org@lifeelectronics.ru