



SY88083L

1G to 12.5G Limiting Post Amplifier with Digital Offset Correction

Revision 1.0

General Description

The SY88083L limiting post amplifier is designed for use in fiber-optic receivers for continuous mode, multi-rate applications from 1Gbps to 12.5Gbps.

The SY88083L contains a high-bandwidth, high-sensitivity input stage with user-programmable, wide-range SD assert/LOS de-assert threshold levels, which enables optimized system reach. Typically, 4dB of electrical hysteresis is provided to minimize LOS or SD chattering caused by noisy input signals. A logic level control pin is provided to enable user selection of an open-collector, TTL-compatible LOS or SD status indication signal with an external 5k Ω to 10k Ω pull-up resistor.

The SY88083L provides faster SD assert and LOS de-assert times than typical continuous mode devices over the entire differential input voltage range of 10mV_{PP} to 1800mV_{PP}.

The SY88083L input stage also provides a user-selectable digital offset correction (DOC) function to automatically compensate for internal device offsets in the high-speed data path.

The SY88083L provides integrated 50 Ω input and output impedances to optimize the high-speed signal paths and reduce component count. A TTL-compatible JAM input is provided to enable a SQUELCH function by feeding back the LOS or SD signal. The JAM input disables only the post amplifier output.

The SY88083L operates from a single +3.3V power supply, over temperatures ranging from -40°C to +85°C.

Datasheets and support documentation are available on Micrel's web site at: www.micrel.com.

Features

- Multi-rate operation from 1.0625Gbps to 12.5Gbps
- Selectable digital offset correction for internal offset compensation in the high-speed data path
- Wide differential input range (10mV_{PP} to 1800mV_{PP})
- Wide SD de-assert or LOS assert threshold range
 - 4.5mV_{PP} to 30mV_{PP}
 - 4dB typical electrical hysteresis
- Fast SD assert and LOS de-assert times
 - 1 μ s typical; 2 μ s maximum
- Selectable LOS or SD status signal indicator
- TTL-compatible JAM input with internal pull-up
- Low-noise CML data inputs with integrated 50 Ω termination impedance to internal reference V_{REF}
- Low-noise CML data outputs with integrated 50 Ω termination impedance
 - 30ps typical rise/fall times
- Wide range power supply: 3.3V \pm 10%
- Industrial temperature range: -40°C to +85°C
- Available in a tiny 3mm \times 3mm QFN package

Applications

- 10G/8G Fibre Channel
- 10Gigabit Ethernet
- OTN equipment
- SONET OC192; SDH STM64
- WDM/DWDM systems

Markets

- Fibre Channel storage area networks
- Datacom/Enterprise
- High-performance computing
- Telecom
- Wireless base stations

Typical Application Circuit

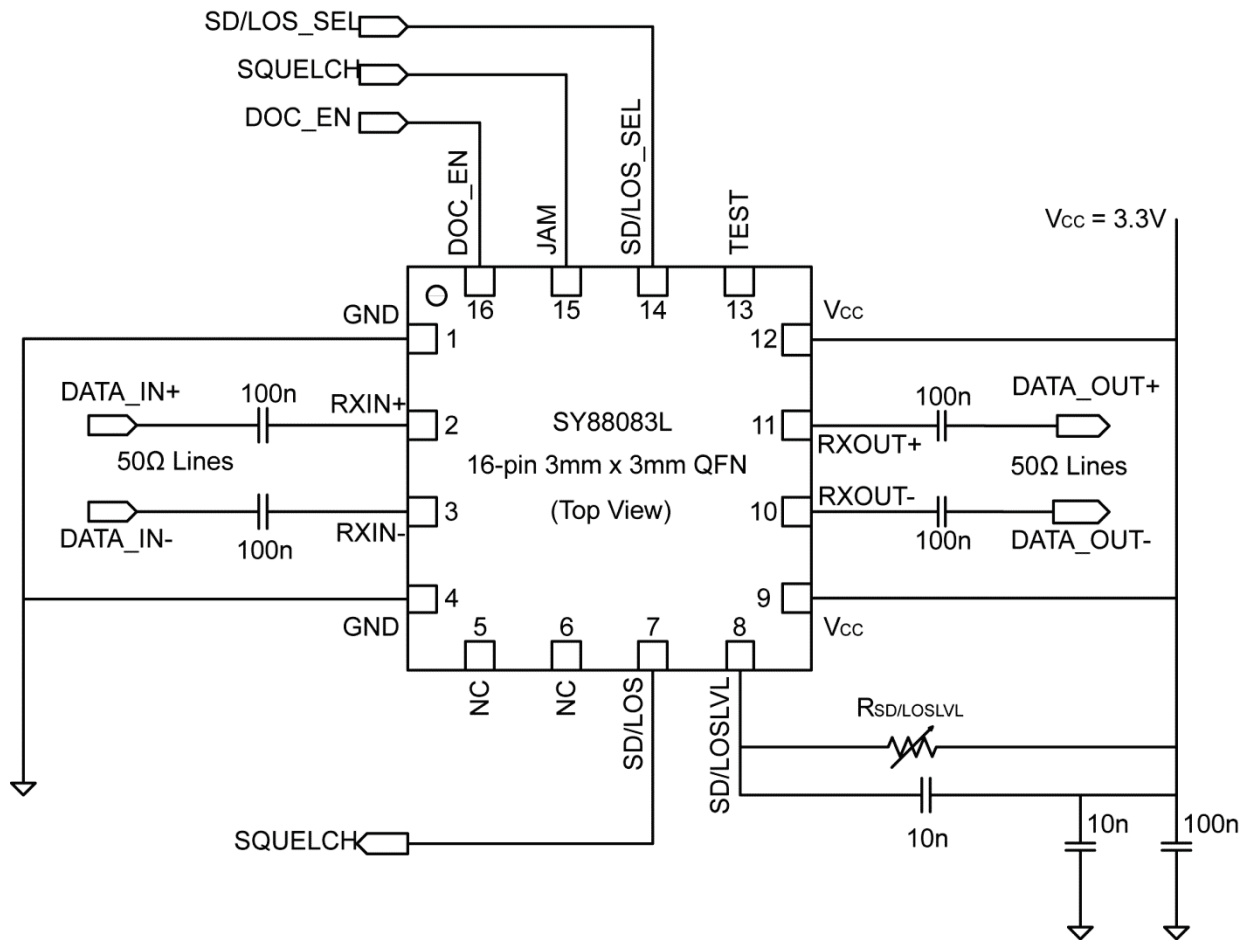

Ordering Information

Part Number	Package Type	Operating Range	Package Marking	Lead Finish
SY88083LMG	3mm × 3mm QFN-16	Industrial	083L with Pb-Free bar-line indicator	NiPdAu Pb-Free
SY88083LMG TR ⁽¹⁾	3mm × 3mm QFN-16	Industrial	083L with Pb-Free bar-line indicator	NiPdAu Pb-Free

Note:

1. Tape and reel.

Pin Configuration

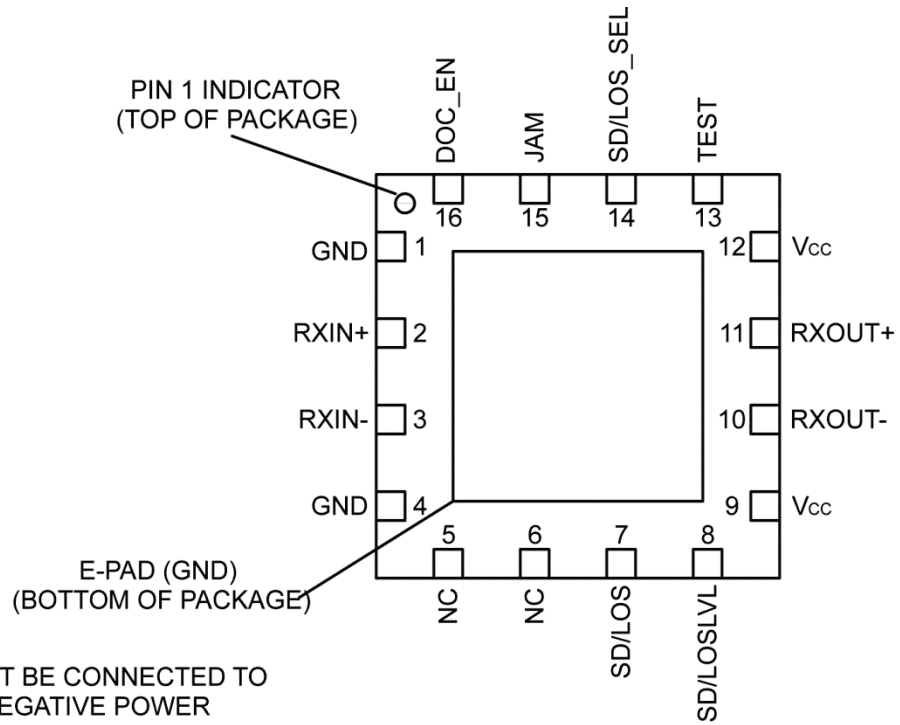

NOTE
E-PAD MUST BE CONNECTED TO
THE PCB NEGATIVE POWER
SUPPLY PLANE USING THE
RECOMMENDED VIA ARRAY

**16-Pin 3mm × 3mm QFN
(Top View)**

Pin Description

Pin Number	Pin Name	Pin Type	Pin Function
1	GND	Negative Supply Rail	Negative Supply Rail. Connect to the PCB negative power supply plane that is also connected to the ePad.
2	RXIN+	High-Speed Data Input	Differential Noninverting Data Input. LVPECL/CML compatible. AC-coupled with 100nF (high-frequency, low-ESR capacitor is recommended). Internally terminated with 50Ω to $V_{CC} - 0.9V$. AC-coupled only.
3	RXIN-	High-Speed Data Input	Differential Inverting Data Input. LVPECL/CML-compatible. AC-coupled with 100nF (high-frequency, low-ESR capacitor is recommended). Internally terminated by 50Ω to $V_{CC} - 0.9V$. AC-coupled only.
4	GND	Negative Supply Rail	Negative Supply Rail. Connect to the PCB negative power supply plane that is also connected to the ePad.
5	NC	No Connect	No Connect. Do not connect to logic circuits or power supply rails.
6	NC	No Connect	No Connect. Do not connect to logic circuits or power supply rails.
7	SD/LOS	Open Collector Logic Output	Output Status Indicator. Loss-of-signal (LOS) or signal detect (SD) open collector output externally terminated with 5kΩ to 10kΩ resistor to V_{CC} . TTL compatible. LOS = High when RXIN± amplitude falls below the threshold set at the SD/LOSLVL pin. SD = Low when RXIN± amplitude falls below the threshold set at the SD/LOSLVL pin.
8	SD/LOSLVL	Analog Input	Analog control input. Sets the trigger threshold for the LOS or SD status indicator signals. If SD/LOS_SEL = High (LOS selected), connect a resistor from the SD/LOSLVL pin (loss of signal threshold level) to V_{CC} to adjust the LOS_Assert threshold for the RXIN± data inputs. If SD/LOS_SEL = Low (SD selected), connect a resistor from the SD/LOSLVL pin (signal detect threshold level) to V_{CC} to adjust the SD_De-assert threshold for the RXIN± data inputs.
9, 12	V_{CC}	Positive Supply Rail	Positive power supply input. Bypass with a 0.1μF capacitor in parallel with a 0.01μF low-ESR capacitor to GND as close as possible to the V_{CC} pin.
10	RXOUT-	High-Speed Data Output	Differential inverting data output. CML compatible and internally terminated by 50Ω to V_{CC} . Can be AC- or DC-coupled to downstream devices.
11	RXOUT+	High-Speed Data Output	Differential noninverting data output. CML compatible and internally terminated by 50Ω to V_{CC} . Can be AC- or DC-coupled to downstream devices.
13	TEST	Test Pin	Factory test pin. For factory use only. Do not connect to logic circuits or power supply rails.
14	SD/LOS_SEL	Logic Level Input	Input control signal. TTL-compatible logic input signal to select LOS or SD as the output signal. Internal ~18kΩ pull-up to V_{CC} . Default = High (NC): LOS selected – normal operation LOS/SD_SEL = Low: SD selected and JAM operation is inverted
15	JAM	Logic Level Input	Input control signal. TTL-compatible input signal that enables or disables the RXOUT± output signals. Internal 27kΩ pull-up resistor to V_{CC} . Can be connected to SD/LOS to form a SQUELCH function. When SD/LOS_SEL = High Default = High and RXOUT± outputs are disabled. Low = RXOUT± outputs are enabled Operation is inverted when SD/LOS_SEL = Low and SD is selected.

Pin Description (Continued)

Pin Number	Pin Name	Pin Type	Pin Function
16	DOC_EN	Logic Level Input	<p>Input Control Signal. TTL-compatible logic input signal that enables or disables the digital offset correction (DOC) circuit.</p> <p>Default: DOC_EN = High = Enable with internal 18kΩ pull-up to V_{CC} if not connected to an external logic low or high signal. DOC_EN = Low disables the digital offset correction function.</p> <p>Toggleing the DOC_EN signal from high to low to high will cause a reset of the DOC circuitry and initiate a new DOC routine to lock in new DOC values.</p> <p>Note: Digital offset correction is not applied to large input signals.</p>
ePad	GND	Negative Supply Rail	Exposed Thermal Pad. Must be soldered to PCB plane connected to the negative supply rail. The recommended via array is needed to remove heat from the device.

Absolute Maximum Ratings⁽²⁾

Supply Voltage (V_{CC})	0V to +4.0V
Input Voltage ($RXIN_{\pm}$)	$V_{CC} - 1.5V$ to V_{CC}
CML Output Voltage (V_{OUT})	$V_{CC} - 1.0V$ to $V_{CC} + 0.5V$
JAM Voltage	0 to V_{CC}
SD/LOSLVL Voltage	$V_{CC} - 1.3V$ to V_{CC}
Lead Temperature (soldering, 20s)	260°C
Storage Temperature (T_s)	-65°C to +150°C

Operating Ratings⁽³⁾

Supply Voltage (V_{CC})	+3.0V to +3.6V
Ambient Temperature (T_A)	-40°C to +85°C
Junction Temperature (T_J)	-40°C to +120°C
Package Thermal Resistance ⁽⁴⁾	
QFN (θ_{JA}) Still-Air	60°C/W
QFN (ψ_{JB})	33°C/W

DC Electrical Characteristics

$V_{CC} = 3.0$ to $3.6V$; $T_A = -40^{\circ}C$ to $+85^{\circ}C$, typical values at $V_{CC} = 3.3V$, $T_A = 25^{\circ}C$.

Symbol	Parameter	Condition	Min.	Typ.	Max.	Units
I_{CC}	Power Supply Current	Note 5		60	75	mA
SD/LOSLVL	SD or LOS Threshold Voltage		$V_{CC} - 1.3$		V_{CC}	V
V_{OH}	$RXOUT_{\pm}$ High Voltage		$V_{CC} - 0.020$	$V_{CC} - 0.005$	V_{CC}	V
V_{OL}	$RXOUT_{\pm}$ Low Voltage		$V_{CC} - 0.400$	$V_{CC} - 0.350$	$V_{CC} - 0.300$	V
$V_{OS_DOC_ON}$	Differential Output Offset	Digital Offset Correction = ON		± 10		mV
Z_0	Single-Ended Output Impedance		45	50	55	Ω
Z_I	Single-Ended Input Impedance		45	50	55	Ω

Notes:

- Permanent device damage may occur if absolute maximum ratings are exceeded. This is a stress rating only and functional operation is not implied at conditions other than those detailed in the operational sections of this datasheet. Exposure to absolute maximum ratings conditions may affect device reliability.
- The datasheet limits are not guaranteed if the device is operated beyond the recommended operating conditions.
- Package thermal resistance assumes that the exposed pad is soldered (or equivalent) to the devices most negative potential on the PCB. ψ_{JB} and θ_{JA} assumes still air and a 4-layer PCB, unless otherwise stated. It also assumes that the recommended via pattern and via sizes on the PCB are used.
- DOC is enabled, outputs $RXOUT_{\pm}$ are loaded with external 50Ω loads, and the outputs are enabled.

TTL DC Electrical Characteristics

$V_{CC} = 3.0$ to $3.6V$; $T_A = -40^{\circ}C$ to $+85^{\circ}C$, typical values at $V_{CC} = 3.3V$, $T_A = 25^{\circ}C$.

Symbol	Parameter	Condition	Min.	Typ.	Max.	Units
V_{IH}	JAM, DOC_EN, SD/LOS_SEL Input High Voltage		2.0			V
V_{IL}	JAM, DOC_EN, SD/LOS_SEL Input Low Voltage				0.8	V
I_{IH}	JAM, DOC_EN, SD/LOS_SEL Input High Current	$V_{IN} = 2.7V$			20	μA
		$V_{IN} = V_{CC}$			100	
I_{IL}	JAM, DOC_EN, SD/LOS_SEL Input Low Current	$V_{IN} = 0.4V$	-0.3			mA
V_{OH}	SD or LOS Output High Level	Sourcing 100 μA	2.4			V
V_{OL}	SD or LOS Output Low Level	Sinking 2mA			0.4	V

AC Electrical Characteristics

$V_{CC} = 3.3V \pm 10\%$, $T_A = -40^\circ\text{C}$ to $+85^\circ\text{C}$. Typical values at $V_{CC} = 3.3V$, $T_A = 25^\circ\text{C}$; $R_{LOAD} = 50\Omega$ to V_{CC} .

Symbol	Parameter	Condition	Min.	Typ.	Max.	Units
t_r, t_f	Output Rise/Fall Time (20% to 80%)	Note 6		30	45	ps
t_{JITTER}	Deterministic	Note 7		10		ps
	Random	Note 8		1		
V_{ID}	Differential Input Voltage Swing	Note 10. See Figure 1.	10		1800	mV _{PP}
V_{OD}	Differential Output Voltage Swing	Note 6	600	700	800	mV _{PP}
t_{LOS_D} ; t_{LOS_A} t_{SD_D} ; t_{SD_A}	LOS De-assert, LOS Assert Time SD De-assert, SD Assert Time	Note 11		1	2	us
LOS_{AM_10k}	Medium LOS Assert Level	$R_{LOSLVL} = 10k\Omega$, Note 9		4.5		mV _{PP}
LOS_{DM_10k}	Medium LOS De-assert Level	$R_{LOSLVL} = 10k\Omega$, Note 9		7.3		mV _{PP}
HYS_{M_10k}	Medium LOS Hysteresis	$R_{LOSLVL} = 10k\Omega$, Note 12	2	4.1	6	dB
LOS_{AH1_1k}	High1 LOS Assert Level	$R_{LOSLVL} = 1k\Omega$, Note 9		18.6		mV _{PP}
LOS_{DH1_1k}	High1 LOS De-assert Level	$R_{LOSLVL} = 1k\Omega$, Note 9		28.3		mV _{PP}
HYS_{H1_1k}	High1 LOS Hysteresis	$R_{LOSLVL} = 1k\Omega$, Note 12	2	3.6	6	dB
LOS_{AH2_100}	High2 LOS Assert Level	$R_{LOSLVL} = 100\Omega$, Note 9		29.7		mV _{PP}
LOS_{DH2_100}	High2 LOS De-assert Level	$R_{LOSLVL} = 100\Omega$, Note 9		44.6		mV _{PP}
HYS_{H2_100}	High2 LOS Hysteresis	$R_{LOSLVL} = 100\Omega$, Note 12	2	3.5	6	dB
$A_{V(Diff)_063C}$	Differential Voltage Gain			44		dB
S_{21_063C}	Single-Ended Small-Signal Gain		32	38		dB
t_{DOC_DELAY}	DOC Delay Time			15		μs
t_{DOC_LOCK}	DOC Lock Time			150		μs

Note:

6. Amplifier is in limiting mode. Input is a 200MHz square wave.
7. Deterministic jitter is measured using 10Gbps K28.5 pattern, $V_{ID} = 20\text{mV}_{PP}$.
8. Random jitter is measured using 10Gbps K28.7 pattern, $V_{ID} = 20\text{mV}_{PP}$.
9. See "Typical Operating Characteristics" for a graph showing how to choose a particular R_{LOSLVL} for a particular LOS assert and its associated de-assert amplitude.
10. Differential input swing amplitude for data rates up to 12.5Gbps
11. In real world applications, the LOS de-assert/assert time can be strongly influenced by the RC time constant of the AC-coupling capacitor and the 50Ω input termination. To keep this time low, use a decoupling capacitor with the lowest value that is allowed by the data rate and the number of consecutive identical bits in the application (typical values are in the range of $0.001\mu\text{F}$ to $0.1\mu\text{F}$).
12. This specification defines electrical hysteresis as $20\log$ (LOS de-assert/LOS assert). The ratio between optical hysteresis and electrical hysteresis is found to vary between 1.5 and 2, depending on the level of received optical power and ROSA characteristics.

Typical Operating Characteristics

$V_{CC} = 3.3V$, $T_A = 25^\circ C$, $R_{LOAD} = 50\Omega$ to V_{CC} , unless otherwise stated.

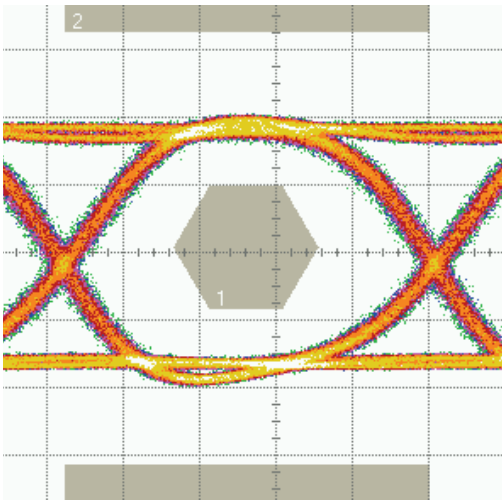
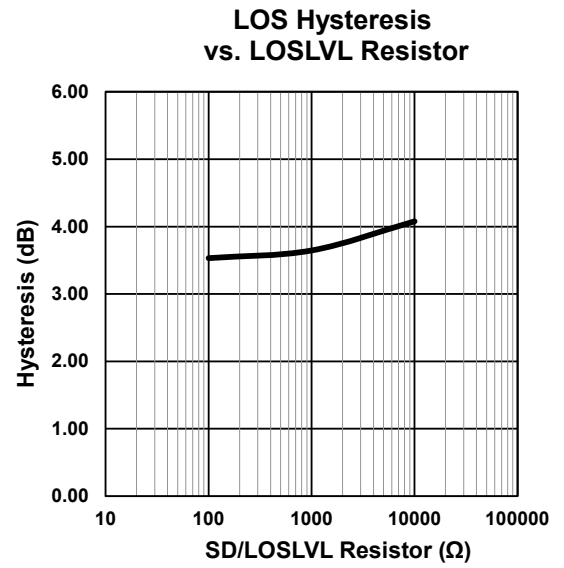
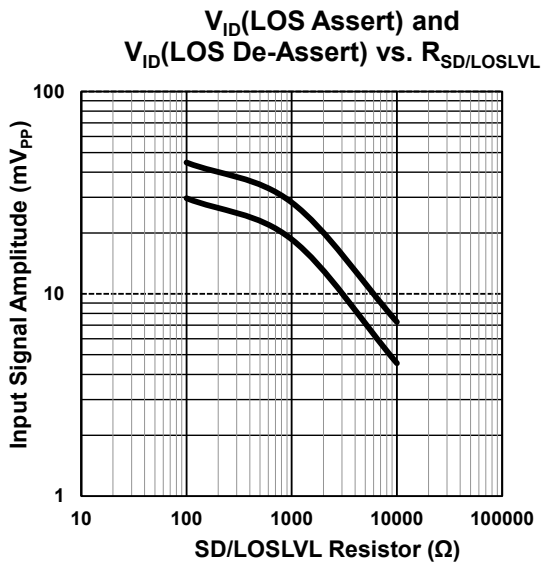

20 ps/div,
Typical 10.3G Output with 10mV_{PP} Input Signal

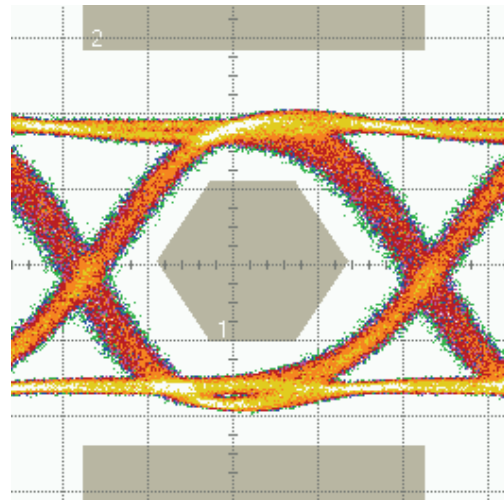

20 ps/div,
Typical 12.5G Output with 10mV_{PP} Input Signal

Functional Block Diagram

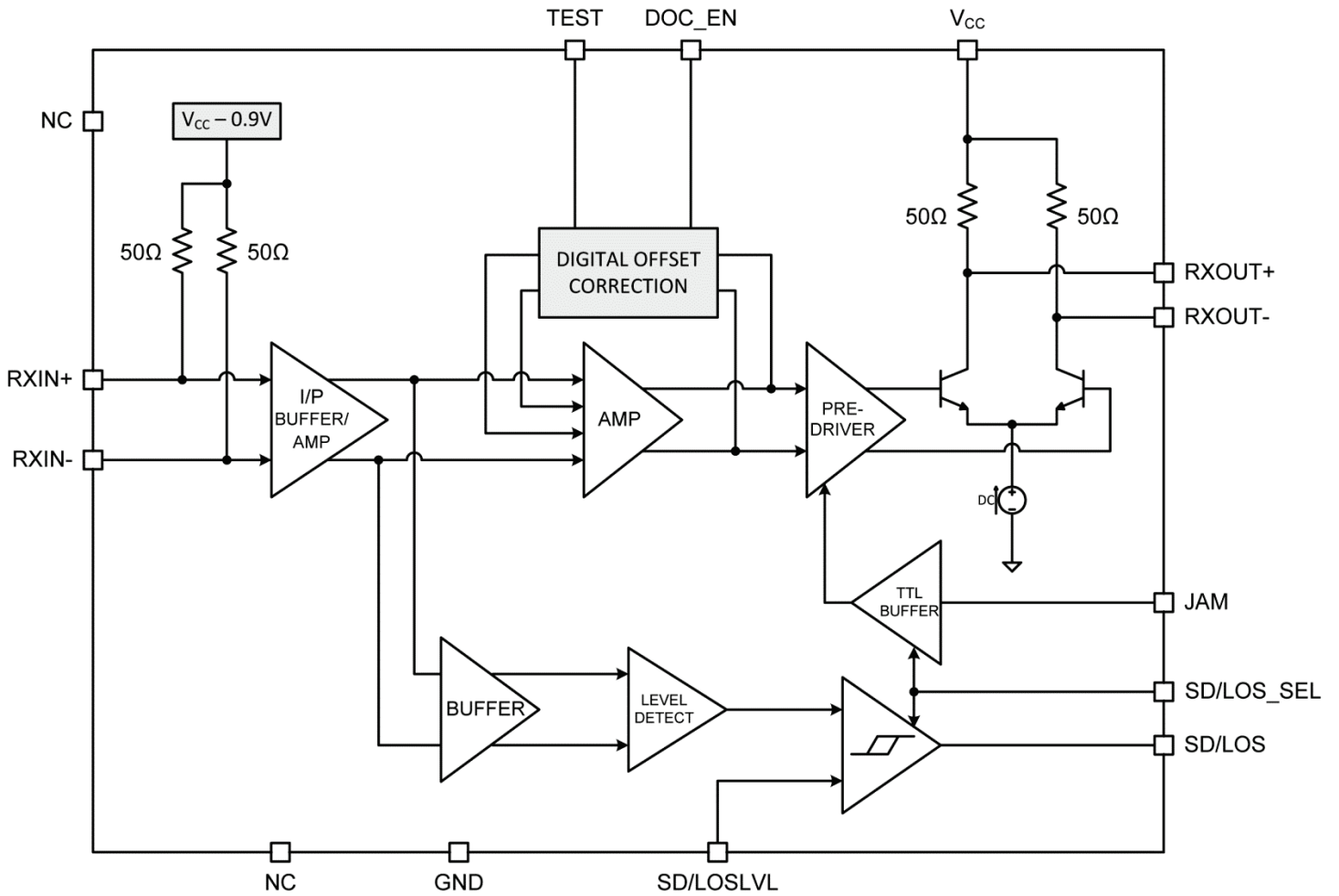

Functional Description

The SY88083L is a high-sensitivity, high-bandwidth limiting post amplifier. It operates from a single +3.3V power supply across the entire industrial temperature range of -40°C to $+85^{\circ}\text{C}$.

Signals with data rates from 1.0625Gbps to 12.5Gbps and amplitudes as small as 10mV_{PP} are supported. [Figure 1](#) shows the allowed input voltage swing.

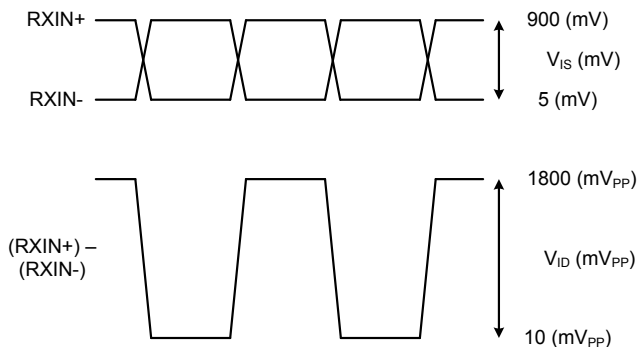

Figure 1. V_{IS} and V_{ID} Definition

The SY88083L has a selectable SD or LOS status output signal that can be fed back to the JAM input to perform the SQUELCH function for output stability if there is no signal at the input. SD/LOSLVL sets the sensitivity of the input amplitude detection.

The SY88083L has a user-selectable, integrated digital offset correction function to cancel internally generated output offsets.

Input Amplifier/Buffer

[Figure 2](#) shows a simplified schematic of the input stage. The high sensitivity of the input amplifier allows signals as small as 10mV_{PP} to be detected and amplified. The input amplifier allows input signals as large as $1800\text{mV}_{\text{PP}}$. Input small signals are amplified with a typical 44dB differential voltage gain.

Output Buffer

The SY88083L CML output buffer is designed to drive 50Ω impedance transmission lines and is internally terminated with 50Ω to V_{CC} . [Figure 3](#) shows a simplified schematic of the output stage.

Signal Detect/Loss-of-Signal (SD/LOS)

The SY88083L generates a user-selectable (SD/LOS_SEL pin) signal detect (SD) or loss-of-signal (LOS) open-collector TTL output, as shown in [Figure 4](#). LOS is used to determine whether the input amplitude is too small to be considered as a valid input. LOS asserts high if the input amplitude falls below the threshold set by

SD/LOSLVL and de-asserts low otherwise. LOS can be fed back to the JAM input to perform the SQUELCH function and to maintain output stability under a LOS condition. JAM de-asserts the true output signal low without removing the input signals. Typically, 4dB LOS hysteresis is provided to prevent chattering.

When SD/LOS_SEL is used to select the SD output on the SD/LOS pin, SD is asserted when the differential input signal amplitude exceeds the level set by the SD/LOSLVL resistor. The JAM operation is inverted when SD is selected.

Signal Detect/Loss-of-Signal Level Setting

A programmable SD/LOS level set pin (SD/LOSLVL) sets the threshold of the input amplitude detection. Connecting an external resistor between V_{CC} and SD/LOSLVL sets the threshold voltage. This voltage ranges from V_{CC} to $V_{\text{CC}} - 1.3\text{V}$. The external resistor creates a voltage divider between V_{CC} and $V_{\text{CC}} - 1.3\text{V}$, as shown in [Figure 5](#).

Hysteresis

The SY88083L provides typically 4dB LOS electrical hysteresis, which is defined as $20\log(V_{\text{IN_LOS_De-Assert}} \div V_{\text{IN_LOS_Assert}})$. Because the relationship of the voltage output of the ROSA to optical power at its input is linear, the optical hysteresis is typically half of the electrical hysteresis reported in the datasheet. In practice the ratio between electrical and optical hysteresis is found to be between 1.5 and 1.8. Thus, 4dB electrical hysteresis corresponds to an optical hysteresis within the range of 2dB to 2.4dB.

Digital Offset Correction (DOC)

The digital offset correction (DOC) circuit compensates for the inherent offsets found in high-gain amplifier circuits and minimizes the offset seen at the outputs. DOC is a user-selectable feature using the DOC_EN pin as defined in the “[Pin Description](#)” table.

Conventional analog offset compensation techniques may be susceptible to drift from long continuous identical digit (CID) patterns. They can also add additional cost due to the extra DAC and manufacturing setup time needed to optimize each individual module. The SY88083L avoids both of these issues and provides a performance/cost optimized solution.

The DOC circuitry automatically detects any internal device offsets and locks the correction values but does not apply offset correction to large input signals.

The DOC is enabled by default unless DOC_EN is pulled low by an external logic level signal. It can be reset by toggling the DOC_EN pin high-to-low-to-high. The DOC reset routine typically completes in $200\mu\text{s}$.

Functional Circuit Structures

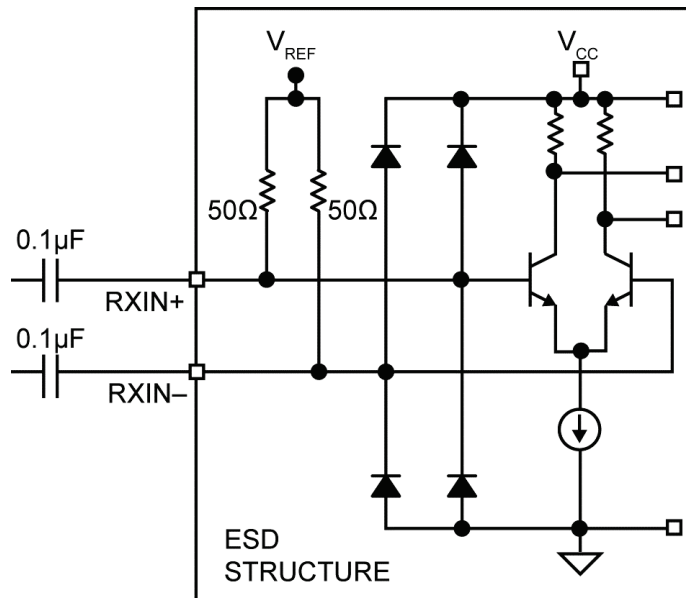

Figure 2. Input Structure

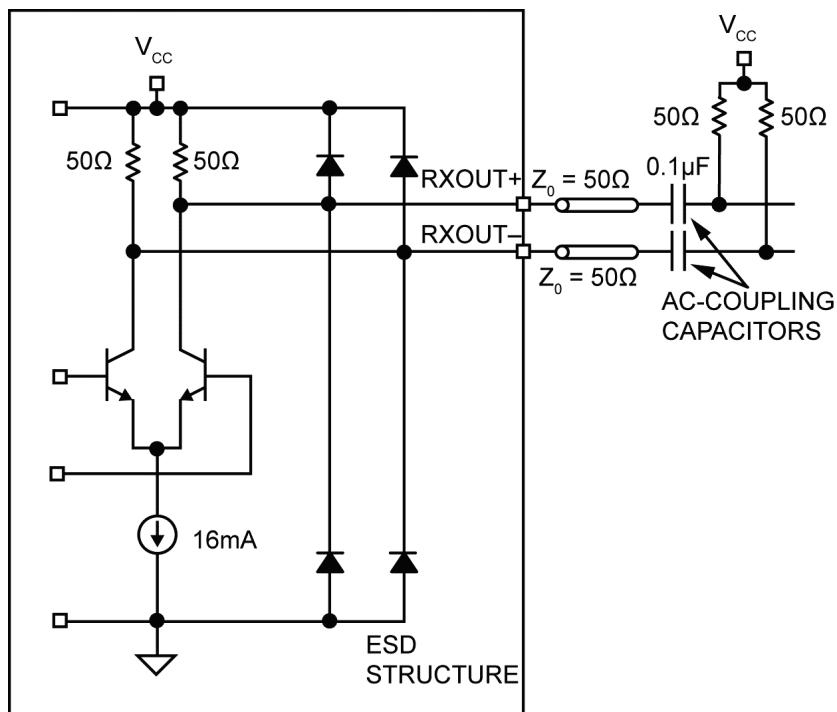

Figure 3. Output Structure

Functional Circuit Structures (Continued)

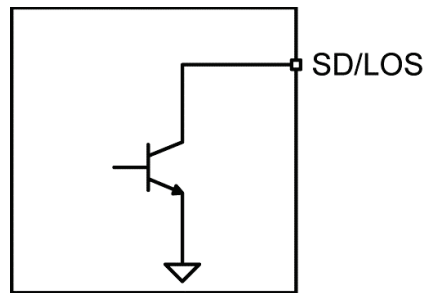

Figure 4. SD/LOS Output Structure

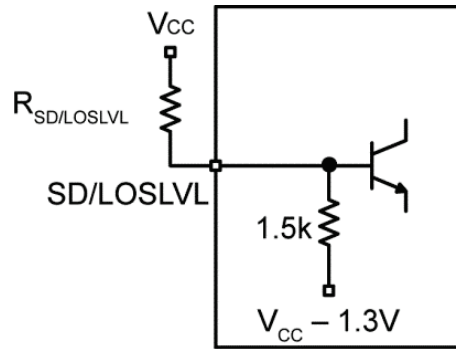
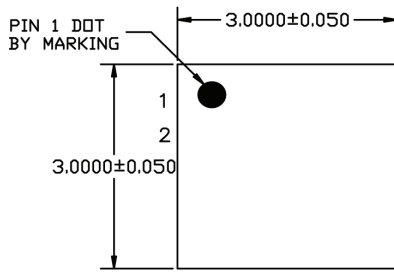

Figure 5. SD/LOSLVL Setting Circuit

Related Product and Support Documentation

Document Number	Title	Application Note Link
AN-45	Notes on Sensitivity and Hysteresis in Micrel Post Amplifiers	www.micrel.com/_PDF/HBW/App-Notes/an-45.pdf
SY88073L_83L_EB	SY88073L/SY88083L Evaluation Board	http://www.micrel.com/_PDF/Eval-Board/SY88073L_83L_EB.pdf

Package Information⁽¹²⁾



TOP VIEW
NOTE: 1, 2, 3

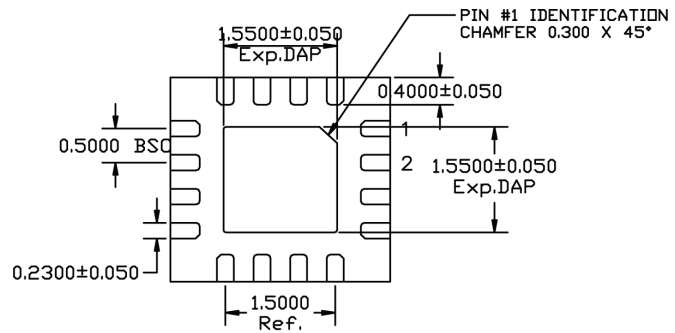

BOTTOM VIEW
NOTE: 1, 2, 3

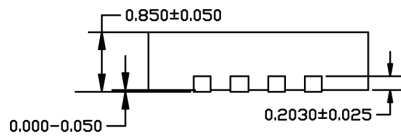

SIDE VIEW
NOTE: 1, 2, 3

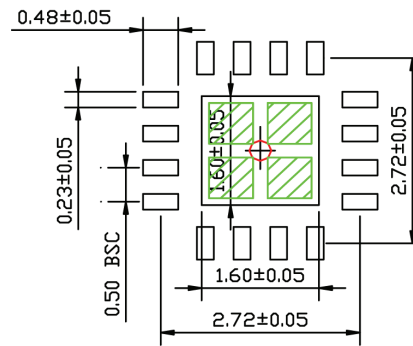

RECOMMENDED LAND PATTERN
NOTE: 4, 5

- NOTE:
1. MAX PACKAGE WARPAGE IS 0.05 MM
 2. MAX ALLOWABLE BURR IS 0.076MM IN ALL DIRECTIONS
 3. PIN #1 IS ON TOP WILL BE LASER MARKED
 4. RED CIRCLE IN LAND PATTERN INDICATE THERMAL VIA. SIZE SHOULD BE 0.30-0.3M IN DIAMETER AND SHOULD BE CONNECTED TO GND FOR MAX THERMAL PERFORMANCE
 5. GREEN RECTANGLES (SHADED AREA) INDICATE SOLDER STENCIL OPENING ON EXPOSED PAD AREA. SIZE SHOULD BE 0.60x0.60 MM IN SIZE, 0.20 MM SPACING.

16-Pin (3mm × 3mm) QFN-16

Note:

13. Package information is correct as of the publication date. For updates and most current information, go to www.micrel.com.

MICREL, INC. 2180 FORTUNE DRIVE SAN JOSE, CA 95131 USA
TEL +1 (408) 944-0800 FAX +1 (408) 474-1000 WEB <http://www.micrel.com>

Micrel makes no representations or warranties with respect to the accuracy or completeness of the information furnished in this data sheet. This information is not intended as a warranty and Micrel does not assume responsibility for its use. Micrel reserves the right to change circuitry, specifications and descriptions at any time without notice. No license, whether express, implied, arising by estoppel or otherwise, to any intellectual property rights is granted by this document. Except as provided in Micrel's terms and conditions of sale for such products, Micrel assumes no liability whatsoever, and Micrel disclaims any express or implied warranty relating to the sale and/or use of Micrel products including liability or warranties relating to fitness for a particular purpose, merchantability, or infringement of any patent, copyright or other intellectual property right.

Micrel Products are not designed or authorized for use as components in life support appliances, devices or systems where malfunction of a product can reasonably be expected to result in personal injury. Life support devices or systems are devices or systems that (a) are intended for surgical implant into the body or (b) support or sustain life, and whose failure to perform can be reasonably expected to result in a significant injury to the user. A Purchaser's use or sale of Micrel Products for use in life support appliances, devices or systems is a Purchaser's own risk and Purchaser agrees to fully indemnify Micrel for any damages resulting from such use or sale.

© 2013 Micrel, Incorporated.

Компания «Life Electronics» занимается поставками электронных компонентов импортного и отечественного производства от производителей и со складов крупных дистрибьюторов Европы, Америки и Азии.

С конца 2013 года компания активно расширяет линейку поставок компонентов по направлению коаксиальный кабель, кварцевые генераторы и конденсаторы (керамические, пленочные, электролитические), за счёт заключения дистрибьюторских договоров

Мы предлагаем:

- Конкурентоспособные цены и скидки постоянным клиентам.
- Специальные условия для постоянных клиентов.
- Подбор аналогов.
- Поставку компонентов в любых объемах, удовлетворяющих вашим потребностям.
- Приемлемые сроки поставки, возможна ускоренная поставка.
- Доставку товара в любую точку России и стран СНГ.
- Комплексную поставку.
- Работу по проектам и поставку образцов.
- Формирование склада под заказчика.
- Сертификаты соответствия на поставляемую продукцию (по желанию клиента).
- Тестирование поставляемой продукции.
- Поставку компонентов, требующих военную и космическую приемку.
- Входной контроль качества.
- Наличие сертификата ISO.

В составе нашей компании организован Конструкторский отдел, призванный помогать разработчикам, и инженерам.

Конструкторский отдел помогает осуществить:

- Регистрацию проекта у производителя компонентов.
- Техническую поддержку проекта.
- Защиту от снятия компонента с производства.
- Оценку стоимости проекта по компонентам.
- Изготовление тестовой платы монтаж и пусконаладочные работы.

