

# High EMI resistance accelerometers

## HV100 and HV200 series

Wilcoxon’s HV series are designed for demanding applications requiring high electrical isolation between the sensor and machine. HV sensors can withstand arcing between the sensor base and its internal electronics to levels as high as 6,000 volts. The sensors offer improved EMI resistance in areas where high electromagnetic interference occurs, such as wind turbines, railway systems and other high-voltage generators. Improvements in EFT and ESD resistance improve survivability during extreme transient events. The HV series are available with a variety of mounting options to ensure compatibility with every application.



### Models available

HV models	Output connector	Integral mounting
HV100	4 pin, M12	M8 x 1.25
HV101		1/4-28 UNF
HV102		M6
HV200	2 pin, MIL-5015	1/4-28 UNF
HV201		M8 x 1.25
HV202		M6

### Key features

- Case-base isolated up to 6 kV
- Ideal for power generation applications
- Rapid shock recovery
- Improved EMI resistance
- Manufactured in an approved ISO 9001 facility

### Certifications



Note: Due to continuous process improvement, specifications are subject to change without notice. This document is cleared for public release.

# High EMI resistance accelerometers

## HV100 and HV200 series

### SPECIFICATIONS

Sensitivity, $\pm 5\%$ , 25°C	100 mV/g
Acceleration range, VDC > 22 V	80 g peak
Amplitude nonlinearity	1%
Frequency response:	
$\pm 5\%$	3 - 5,000 Hz
$\pm 10\%$	1 - 7,000 Hz
$\pm 3$ dB	0.5 - 12,000 Hz
Resonance frequency	25 kHz
Transverse sensitivity, max	5% of axial
Temperature response:	
-40°C	-10%
+120°C	+10%
Temperature range	-40° to +120° C
Power requirement:	
Voltage source	18 - 30 VDC
Current regulating diode	2 - 10 mA
Dielectric withstand voltage between connector and surface:	
6,000 VDC	1 min.
5,000 VAC	1 min.
Electrical noise, equiv. g:	
Broadband 2.5 Hz to 25 kHz	700 $\mu$ g
Spectral 10 Hz	10 $\mu$ g/ $\sqrt{\text{Hz}}$
100 Hz	5 $\mu$ g/ $\sqrt{\text{Hz}}$
1,000 Hz	5 $\mu$ g/ $\sqrt{\text{Hz}}$
Output impedance	100 $\Omega$
Impedance, between connector and base:	
DC	>100 G $\Omega$
100 Hz	>100 M $\Omega$
1.0 kHz	>10 M $\Omega$
10 kHz	>1 M $\Omega$
Bias output voltage	12 VDC
Grounding	case isolated, internally shielded
Vibration limit	500 g peak
Shock limit	5,000 g peak
Electromagnetic sensitivity, equiv. g, max	70 $\mu$ g/gauss
Sealing	hermetic
Base strain sensitivity	<0.0002 g/ $\mu$ strain
Sensing element design	PZT, shear
Sensor case material	stainless steel
Isolation material	ceramic
Recommended cabling	J10 / J9T2A

Connections - HV100 series	
Function	Connector pin
signal	P1
to pin 3 inner shield	P2
common	P3
case	P4
connector shell	case

Connections - HV200 series	
Function	Connector pin
signal	A
common	B
connector shell	case

See page 3 for further specifications, dimensions and drawings.

Note: Due to continuous process improvement, specifications are subject to change without notice. This document is cleared for public release.

# HV100 series

SPECIFICATIONS		HV100	HV101	HV102
<b>Output connector<sup>1</sup></b>		4 pin M12	4 pin M12	4 pin M12
<b>Integral mounting</b>		M8 x 1.25 x 8.4 mm	1/4-28 UNF x 0.33 in.	M6 x 1.00 x 6.2 mm
<b>Mounting torque, recommended</b>		40 in-lb / 4.5 Nm	30 in-lb / 3.4 Nm	30 in-lb / 3.4 Nm
<b>Dimensions:</b>	<b>A</b>	1.93 in. (49.5 mm)	1.93 in. (49.5 mm)	1.93 in. (49.5 mm)
	<b>B</b>	0.325 in. (8.3 mm)	0.325 in. (8.3 mm)	0.325 in. (8.3 mm)
	<b>C</b>	1.21 in. (31.0 mm)	1.21 in. (31.0 mm)	1.21 in. (31.0 mm)
<b>Weight</b>		126 grams (4.44 oz)	126 grams (4.44 oz)	126 grams (4.44 oz)

**Notes:** <sup>1</sup> For best performance, it is recommended that the connector shell be tied to the cable shield.

Recommended connector: R75S

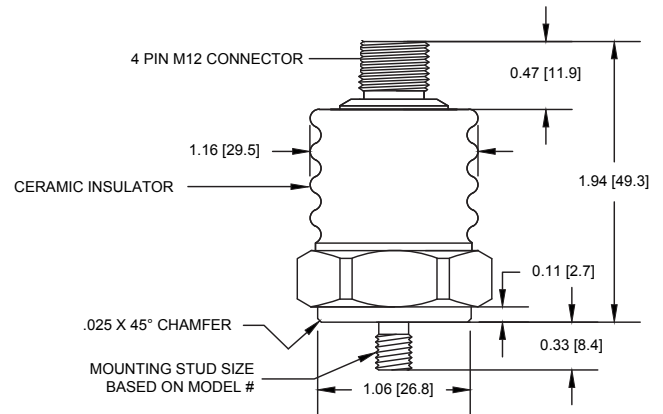
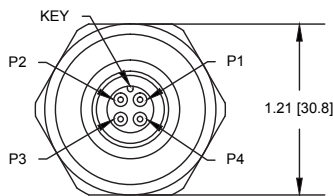

# HV200 series

SPECIFICATIONS		HV200	HV201	HV202
<b>Output connector<sup>1</sup></b>		2 pin MIL-5015	2 pin MIL-5015	2 pin MIL-5015
<b>Integral mounting</b>		1/4-28 UNF x 0.33 in.	M8 x 1.25 x 8.4 mm	M6 x 1.00 x 6.2 mm
<b>Mounting torque, recommended</b>		30 in-lb / 3.4 Nm	40 in-lb / 4.5 Nm	30 in-lb / 3.4 Nm
<b>Dimensions:</b>	<b>A</b>	2.15 in. (55.1 mm)	2.15 in. (55.1 mm)	2.15 in. (55.1 mm)
	<b>B</b>	0.325 in. (8.3 mm)	0.325 in. (8.3 mm)	0.325 in. (8.3 mm)
	<b>C</b>	1.21 in. (31.0 mm)	1.21 in. (31.0 mm)	1.21 in. (31.0 mm)
<b>Weight</b>		122 grams (4.35 oz)	122 grams (4.35 oz)	122 grams (4.35 oz)

**Notes:** <sup>1</sup> For best performance, it is recommended that the connector shell be tied to the cable shield.

Recommended connector: R6Q

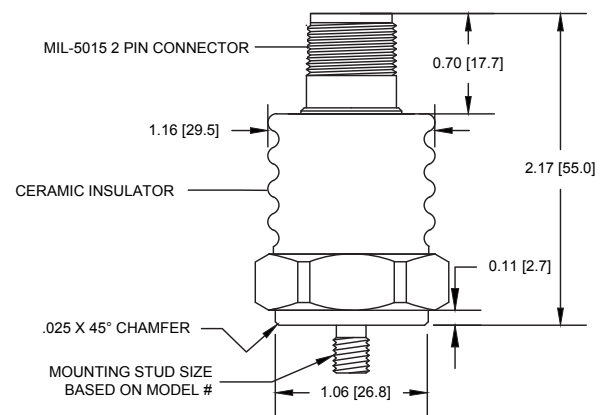
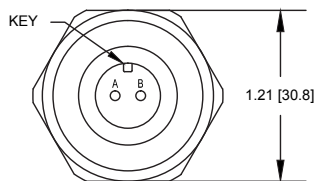

Note: Due to continuous process improvement, specifications are subject to change without notice. This document is cleared for public release.

Компания «Life Electronics» занимается поставками электронных компонентов импортного и отечественного производства от производителей и со складов крупных дистрибьюторов Европы, Америки и Азии.

С конца 2013 года компания активно расширяет линейку поставок компонентов по направлению коаксиальный кабель, кварцевые генераторы и конденсаторы (керамические, пленочные, электролитические), за счёт заключения дистрибьюторских договоров

Мы предлагаем:

- Конкурентоспособные цены и скидки постоянным клиентам.
- Специальные условия для постоянных клиентов.
- Подбор аналогов.
- Поставку компонентов в любых объемах, удовлетворяющих вашим потребностям.
- Приемлемые сроки поставки, возможна ускоренная поставка.
- Доставку товара в любую точку России и стран СНГ.
- Комплексную поставку.
- Работу по проектам и поставку образцов.
- Формирование склада под заказчика.
- Сертификаты соответствия на поставляемую продукцию (по желанию клиента).
- Тестирование поставляемой продукции.
- Поставку компонентов, требующих военную и космическую приемку.
- Входной контроль качества.
- Наличие сертификата ISO.

В составе нашей компании организован Конструкторский отдел, призванный помогать разработчикам, и инженерам.

Конструкторский отдел помогает осуществить:

- Регистрацию проекта у производителя компонентов.
- Техническую поддержку проекта.
- Защиту от снятия компонента с производства.
- Оценку стоимости проекта по компонентам.
- Изготовление тестовой платы монтаж и пусконаладочные работы.



Тел: +7 (812) 336 43 04 (многоканальный)

Email: [org@lifeelectronics.ru](mailto:org@lifeelectronics.ru)