

Transportation Attitude Reference System (TARS Series)

Ruggedized Inertial Measurement Unit (IMU)

000828

Issue 2

Datasheet



DESCRIPTION

The Transportation Attitude Reference System or TARS-IMU is a packaged sensor array designed to report vehicle angular rate, acceleration, and attitude data for demanding applications in industries such as heavy duty, off-highway transportation.

TARS-IMU enables autonomous vehicle characteristics and enhances efficiency and productivity by reporting key data required to automate and monitor movements of vehicle systems and components. The sensor fusion algorithm can be customized for specific vehicle applications through on-board firmware, allowing movement data to be filtered for extraneous environment and vehicle movements.

With two sensor models for different power levels, TARS-IMU accommodates both 5 V and 9 V to 36 V vehicle power systems. While communication is carried to the vehicle through industry standard CAN J1939 connectivity.

As a standard, TARS-IMU is calibrated on aerospace-grade rate tables at the factory to provide calibration consistency between units.

DIFFERENTIATION

- **Flexible.** On-board firmware can tailor TARS-IMU to the specific vehicle and the specific application
- **Durable.** With top-of-the-line sealing (IP67, IP69K) TARS-IMU is ruggedized to withstand harsh or heavy-duty applications
- **Convenient.** TARS-IMU can be pre-configured at the Honeywell factory for immediate installation out of the box, or it can be delivered with customizable firmware that allows manufacturers to use a single part number across vehicles and applications

FEATURES

- High performance IMU reports vehicle angular rate, acceleration and inclination (6 degrees of freedom)
- Ruggedized PBT thermoplastic housing design for the most demanding applications and environments (IP67 and IP69K certified)
- Advanced filtering of raw sensor data to minimize unwanted noise and vibrations, improves positioning accuracy
- Optional metal guard for added protection
- Supports 5 V and 9 V to 36 V vehicle power systems
- Operating temperature of -40°C to 85°C [-40°F to 185°F]
- Reduced power consumption
- Small form-factor

POTENTIAL APPLICATIONS

- Equipment control
- Linkage tracking
- Work monitoring
- Operator assisted control
- Performance and output control
- Linear position
- Bucket control
- Vehicle stability control

VALUE TO CUSTOMERS

- Designed to allow vehicle manufacturers and end users to increase efficiency with the automation of repetitive movements or complex tasks
- Enables precise movement, actuation and guidance over severe terrains and vehicle grades
- Enhances safety through enablement of monitoring and guidance capabilities that improve productivity of operators

SIX DEGREES OF FREEDOM

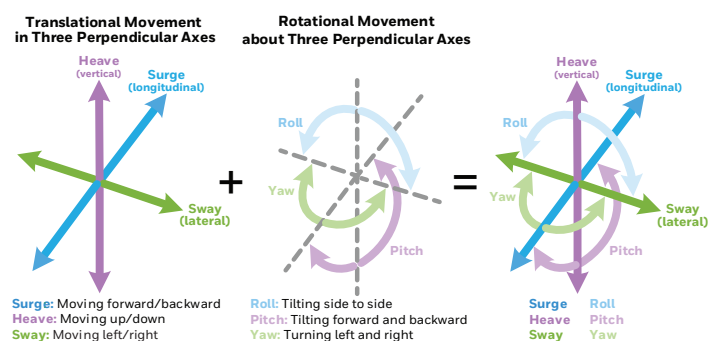

PORTFOLIO

TARS-IMU joins Honeywell's venerated sensor portfolio, and adds to the ever-increasing connected and intelligence driven capabilities that Honeywell offers. TARS-IMU is built to survive the demanding applications in industries like off-highway transportation and beyond.

Transportation Attitude Reference System (TARS Series)

Table 1. Sensor Specifications

Characteristic	Min.	Typ.	Max.	Unit
Gyroscope 3 axis performance				
Angular rate range ¹	-245	–	+245	deg/s
Angular rate resolution	–	7.8125	–	mdps
In-run bias stability	–	1	–	mdps
Rate noise density	–	0.004	–	deg/s/sqrt Hz
Offset (0°C to 50°C)	-0.8	–	+0.8	deg/s
Offset (-40°C to 85°C)	-1.6	–	+1.6	deg/s
Accelerometer 3 axis performance				
Acceleration range ¹	-78.48	–	+78.48	m/s ²
Acceleration resolution	–	0.01	–	m/s ²
In-run bias stability	–	50	–	µg
Acceleration noise density	–	65	–	µg/sqrt Hz
Offset (0°C to 50°C)	–	±0.05	–	m/s ²
Offset (-40°C to 85°C)	–	±0.15	–	m/s ²
Attitude (pitch and roll) performance				
Range ¹	-85	–	+85	deg
Resolution	–	0.058	–	deg
Static error (0°C to 50°C)	–	±0.3	–	deg
Static error (-40°C to 85°C)	–	±0.9	–	deg
Translational acceleration error	–	±0.5	–	deg
Centripetal acceleration error	–	±0.5	–	deg

¹ Sensors are calibrated in the following ranges: ±60 deg/s for gyroscope angular rate, ±9.81 m/s² for acceleration, and ±30 deg for pitch and roll. Calibrated ranges can be extended to maximums shown with deviation to performance specifications.

- Pitch and roll outputs per PGN61481 (Axes marking on the housing is Z-down convention required for pitch and roll outputs per J1939.)
- Acceleration outputs per PGN61485 (Acceleration data is outputted per Z-up convention required by J1939.)
- Angular rate outputs per PGN61482 (Angular rate data is outputted per Z-down convention required by J1939.)

Table 2. Electrical Specifications • TARS-LCASS Catalog Listing

Characteristic	Min.	Nominal	Max.	Unit
Supply voltage	4.5	5	5.5	V
Supply current	–	–	100	mA
Start-up time	500	–	2000	ms
Short circuit protection	CAN output shorted to supply voltage or ground without damage			
Open circuit protection	Single-line interruption and multiple-line interruption			
Reset response	Automatic after voltage dropout			
CAN output characteristics per SAE J1939				
CAN Bus data rate	–	250	–	kBaud
Signal update rate	–	–	100	Hz

Transportation Attitude Reference System (TARS Series)

Table 3. Electrical Specifications • TARS-HCASS Catalog Listing

Characteristic	Min.	Nominal	Max.	Unit
Supply voltage	9	14/28	36	V
Supply current	–	–	100	mA
Reverse voltage	–	–	-36	V
Overvoltage	–	–	36	V
Start-up time	500	–	2000	ms
Short circuit protection	CAN output shorted to supply voltage or ground without damage			
Open circuit protection	Single-line interruption and multiple-line interruption			
Reset response	Automatic after voltage dropout			
CAN output characteristics per SAE J1939				
CAN Bus data rate	–	250	–	kBaud
Signal update rate	–	–	100	Hz

Table 4. Environmental Specifications¹

Characteristic	Parameter
Operating temperature	-40°C to 85°C [40°F to 185°F]
Storage temperature ²	-40°C to 105°C [40°F to 221°F]
Housing	PBT thermoplastic
Random vibration	10 hours at 25 Grms per MIL-STD-810, Method 514.7, Procedure I, Annex D, Category 20, 5 Hz to 500 Hz (flat spectrum)
Mechanical shock	50 g 11 ms half-sine pulse, 3 each direction, 18 total, per MIL-STD-202, Method 213
Chemical compatibility	Diesel fuel, hydraulic oil, ethylene glycol, motor oil, brake fluid, urea nitrogen, liquid lime, NPK fertilizer, ammonium hydroxide, alkaline degreaser, transmission oil, power steering fluid, and axle oil
Moisture resistance	Per MIL-STD-202, Method 106 (10 cycles, 24 hours/cycle)
Thermal shock	250 cycles, -40°C to 85°C, 73 min dwell
Salt spray	5 % salt solution, 96 hours
Ingress protection	IP67, IP69K (DIN40050-1993) with mating connector installed
RoHS	Compliant
REACH	Compliant
UV rating	Housing material meets outdoor suitability requirements per UL746C F1 rating

¹For environmental conditions not covered by product specification, consult with Honeywell Engineering.

²In installed condition; otherwise, maximum storage temperature is 85°C [185°F].

Table 5. EMC Specifications

Characteristic	Standard	Test Level, Frequency
Radiated immunity	ISO 11452-2	125 V/m, 400 MHz to 2.5 GHz
Bulk current injection	ISO 11452-4: 2011	125 mA, 1 MHz to 400 MHz
Radiated emission	ISO 13766	30 MHz to 1 GHz
Mutual coupling	ISO 7637-3	Test pulse A, Test pulse B (-80 V, 80 V)
ESD direct contact discharge	ISO 10605	±8 kV
ESD air discharge	ISO 10605	±15 kV

Transportation Attitude Reference System (TARS Series)

Table 6. Installation Specifications

Characteristic	Parameter
Mating connector	AMPSEAL 16 Series, 776487-1 for 18-16 AWG conductors or 776524-1 for 20-18 AWG conductors
CAN termination	120 Ohm termination resistor, not included in TARS-IMU unit
Weight	170 g approx.
Mounting direction	+Z
Mounting bolt	M8, installation torque 20 Nm ±2 Nm

Table 7. Order Guide

Part Number	Description
TARS-LCASS	TARS Series Inertial Measurement Unit, 5 V, CAN protocol, AMPSEAL 16 termination, standard MEMS chip generation/performance
TARS-HCASS	TARS Series Inertial Measurement Unit, 9 V to 36 V, CAN protocol, AMPSEAL 16 termination, standard MEMS chip generation/performance

Figure 1. Product Nomenclature

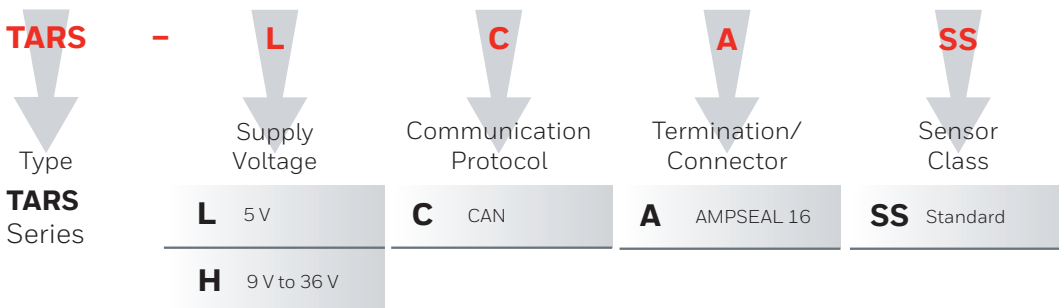
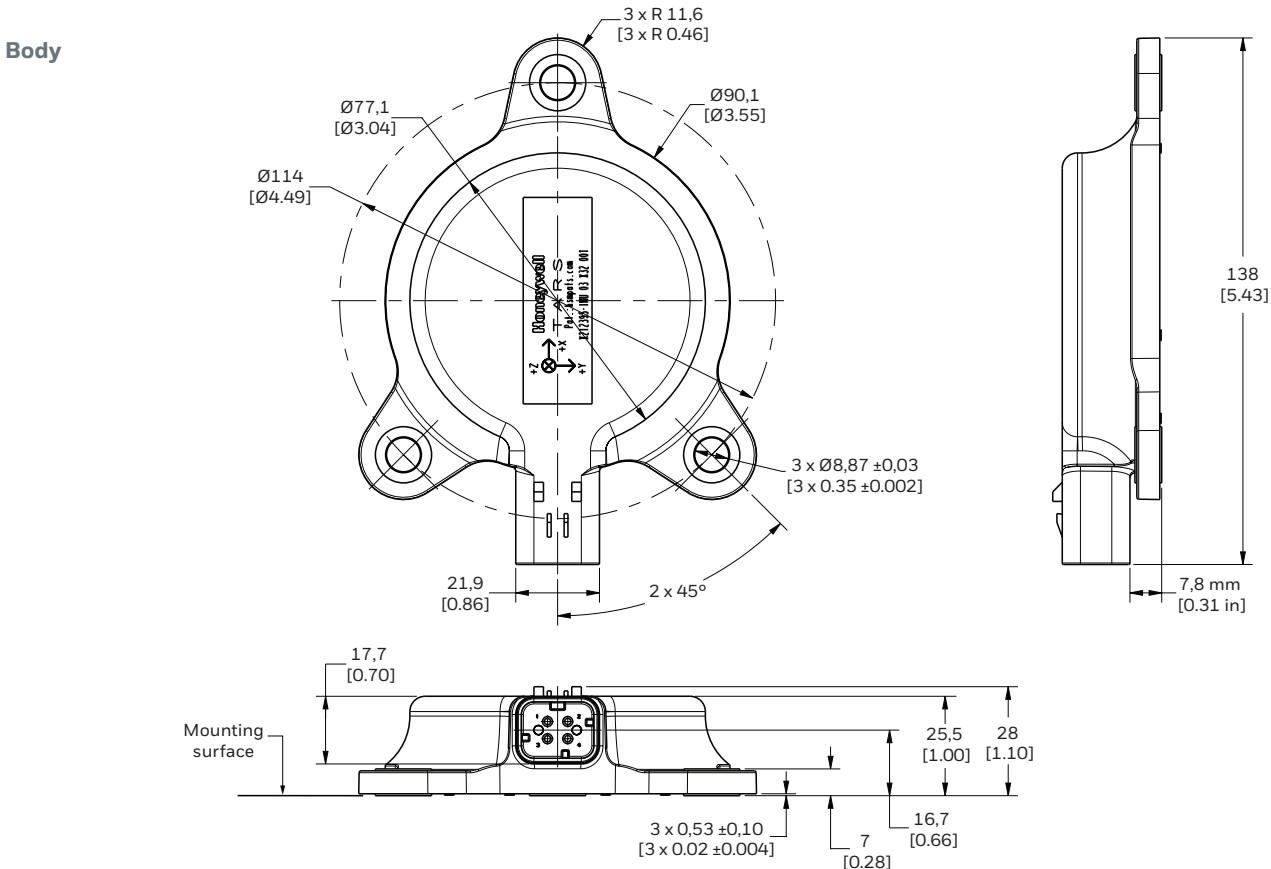

Figure 2. Dimensions (For reference only: mm/[in])



Transportation Attitude Reference System (TARS Series)

Figure 2. Dimensions (continued)

Mounting Holes

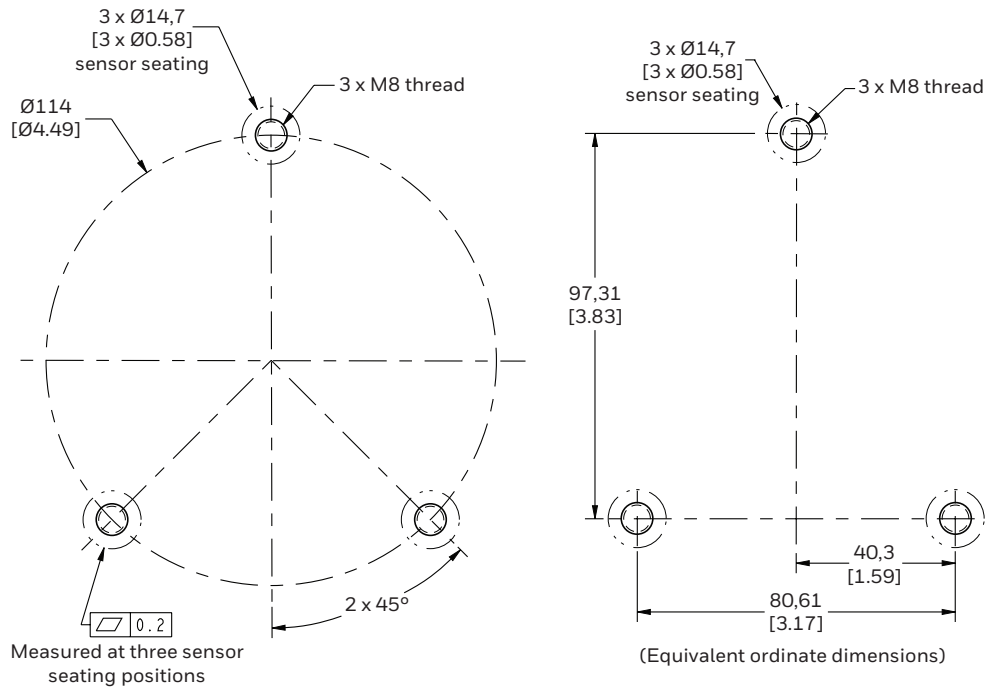

Pinout

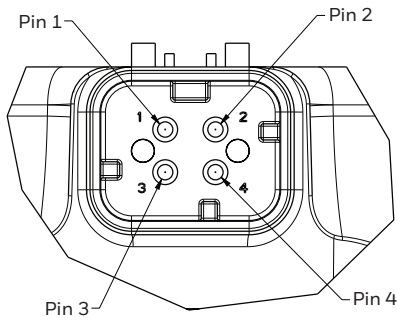

Connector Termination

Pin	Description
1	dc power
2	CAN high
3	Ground
4	CAN low

Marking Information

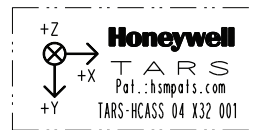

Where

04 Product configuration code

X32 Date code, where:

X: Year code for 2016, Y for 2017, Z for 2018, A for 2019, etc.

32: Week of final test

001 is a consecutive number, different for each product

ADDITIONAL MATERIALS

The following associated literature is available at sensing.honeywell.com:

- Product range guide
- Product installation instructions
- Application notes
- CAD models
- Product images

WARNING **PERSONAL INJURY**

DO NOT USE these products as safety or emergency stop devices or in any other application where failure of the product could result in personal injury.

Failure to comply with these instructions could result in death or serious injury.

WARNING **MISUSE OF DOCUMENTATION**

- The information presented in this product sheet is for reference only. Do not use this document as a product installation guide.
- Complete installation, operation, and maintenance information is provided in the instructions supplied with each product.

Failure to comply with these instructions could result in death or serious injury.

Warranty/Remedy

Honeywell warrants goods of its manufacture as being free of defective materials and faulty workmanship during the applicable warranty period. Honeywell's standard product warranty applies unless agreed to otherwise by Honeywell in writing; please refer to your order acknowledgment or consult your local sales office for specific warranty details. If warranted goods are returned to Honeywell during the period of coverage, Honeywell will repair or replace, at its option, without charge those items that Honeywell, in its sole discretion, finds defective. **The foregoing is buyer's sole remedy and is in lieu of all other warranties, expressed or implied, including those of merchantability and fitness for a particular purpose. In no event shall Honeywell be liable for consequential, special, or indirect damages.**

While Honeywell may provide application assistance personally, through our literature and the Honeywell web site, it is buyer's sole responsibility to determine the suitability of the product in the application.

Specifications may change without notice. The information we supply is believed to be accurate and reliable as of this writing. However, Honeywell assumes no responsibility for its use.

For more information

Honeywell Sensing and Internet of Things services its customers through a worldwide network of sales offices and distributors. For application assistance, current specifications, pricing or the nearest Authorized Distributor, visit sensing.honeywell.com or call:

Asia Pacific	+65 6355-2828
Europe	+44 (0) 1698 481481
USA/Canada	+1-800-537-6945

Honeywell Sensing and Internet of Things

9680 Old Bailes Road
Fort Mill, SC 29707
www.honeywell.com

AMPSEAL™ is a trademark of Tyco Electronics Services GMBH.

000828-2-EN | 2 | 07/18
© 2018 Honeywell International Inc. All rights reserved.

Honeywell

Компания «Life Electronics» занимается поставками электронных компонентов импортного и отечественного производства от производителей и со складов крупных дистрибьюторов Европы, Америки и Азии.

С конца 2013 года компания активно расширяет линейку поставок компонентов по направлению коаксиальный кабель, кварцевые генераторы и конденсаторы (керамические, пленочные, электролитические), за счёт заключения дистрибьюторских договоров

Мы предлагаем:

- Конкурентоспособные цены и скидки постоянным клиентам.
- Специальные условия для постоянных клиентов.
- Подбор аналогов.
- Поставку компонентов в любых объемах, удовлетворяющих вашим потребностям.
- Приемлемые сроки поставки, возможна ускоренная поставка.
- Доставку товара в любую точку России и стран СНГ.
- Комплексную поставку.
- Работу по проектам и поставку образцов.
- Формирование склада под заказчика.
- Сертификаты соответствия на поставляемую продукцию (по желанию клиента).
- Тестирование поставляемой продукции.
- Поставку компонентов, требующих военную и космическую приемку.
- Входной контроль качества.
- Наличие сертификата ISO.

В составе нашей компании организован Конструкторский отдел, призванный помогать разработчикам, и инженерам.

Конструкторский отдел помогает осуществить:

- Регистрацию проекта у производителя компонентов.
- Техническую поддержку проекта.
- Защиту от снятия компонента с производства.
- Оценку стоимости проекта по компонентам.
- Изготовление тестовой платы монтаж и пусконаладочные работы.



Тел: +7 (812) 336 43 04 (многоканальный)

Email: org@lifeelectronics.ru