

ETD-BL-1T-ON- 10S

Time relay with switch-on delay (voltage controlled) and adjustable time

Data sheet
103615_en_03

© PHOENIX CONTACT - 2013-09-16

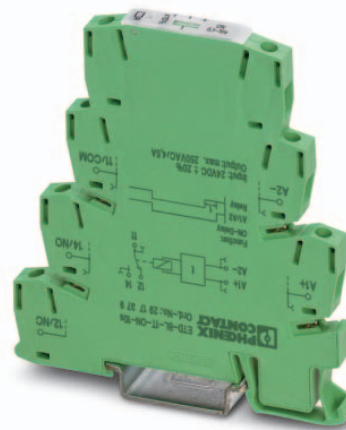

1 Description

Compact timer relay in 6.2 mm housing for controlling time sequences.

The time is set on the front of the device using a labeled thumbwheel, which is recessed to protect against accidental modification. A screwdriver is used to change the settings (blade width 2.5 mm).

The compact timer relays are available with different time ranges as well as with a screw, spring-cage, and push-in connection.

Features

- 6.2 mm narrow housing
- With switch-on delay (voltage controlled)
- Adjustable time
- Easy and accurate time setting
- Supply voltage 24 V DC
- Output: A floating PDT



WARNING: Correct usage in potentially explosive areas

The module is a category 3 item of electrical equipment. Follow the instructions provided here during installation and observe the safety instructions.

Never carry out work when voltage is present.



Make sure you always use the latest documentation.

It can be downloaded from the product at phoenixcontact.net/products.



This data sheet is valid for all products listed on the following page:

2 Ordering data

Description	Type	Order No.	Pcs. / Pkt.
Timer relay with screw connection			
Time range 0.1...10 s	ETD-BL-1T-ON- 10S	2917379	1
Time range 3...300 s	ETD-BL-1T-ON-300S	2917382	1
Time range 0.3...30 min	ETD-BL-1T-ON- 30MIN	2917395	1
Time range 3...300 min	ETD-BL-1T-ON-300MIN	2917405	1
Timer relay with spring-cage connection			
Time range 0.1...10 s	ETD-BL-1T-ON- 10S-SP	2917531	1
Time range 3...300 s	ETD-BL-1T-ON-300S-SP	2917544	1
Time range 0.3...30 min	ETD-BL-1T-ON- 30MIN-SP	2917557	1
Time range 3...300 min	ETD-BL-1T-ON-300MIN-SP	2917560	1
Timer relay with Push-in connection			
Time range 0.1...10 s	ETD-BL-1T-ON- 10S-PT	2901476	1
Time range 3...300 s	ETD-BL-1T-ON-300S-PT	2901477	1
Time range 0.3...30 min	ETD-BL-1T-ON- 30MIN-PT	2901478	1
Time range 3...300 min	ETD-BL-1T-ON-300MIN-PT	2901479	1

3 Technical data

Input data	
Input voltage range	24 V DC (19,2 V DC ...30 V DC)
Time setting range	0.1 s ... 10 s
ETD-BL-1T-ON- 10S	3 s ... 300 s
ETD-BL-1T-ON-300S	0.3 min ... 30 min
ETD-BL-1T-ON- 30MIN	3 min ... 300 min
ETD-BL-1T-ON-300MIN	
ETD-BL-1T-ON- 10S-SP	0.1 s ... 10 s
ETD-BL-1T-ON-300S-SP	3 s ... 300 s
ETD-BL-1T-ON- 30MIN-SP	0.3 min ... 30 min
ETD-BL-1T-ON-300MIN-SP	3 min ... 300 min
ETD-BL-1T-ON- 10S-PT	0.1 s ... 10 s
ETD-BL-1T-ON-300S-PT	3 s ... 300 s
ETD-BL-1T-ON- 30MIN-PT	0.3 min ... 30 min
ETD-BL-1T-ON-300MIN-PT	3 min ... 300 min
Function	ON: With switch-on delay
Setting accuracy	≤ 2.5 % (of scale end value)
Repeat accuracy	≤ 0.5 % (From the measuring range final value)
Nominal current typ.	15 mA (Relay ON) 7 mA (Relay OFF)
Output data	
Contact type	1 floating PDT
Output fuse	6.3 A (fast-blow)
Switching capacity	1500 VA (6 A / 250 V AC)
Control contact	
Control pulse length	min. 50 ms

General data	
Mechanical service life	Approx. 2×10^7 cycles
Service life, electrical	Approx. 2×10^5 cycles at ohmic load, 1000 VA
Operating mode	100% operating factor
Degree of protection	IP20
Pollution degree	2 (according to EN 50178)
Surge voltage category	III, safe isolation (according to EN 50178)
Rated insulation voltage	300 V AC (According to EN 50178)
Impulse withstand voltage	6 kV (According to EN 50178)
Inflammability class according to UL 94	V0
Mounting	on standard DIN rail NS 35 in accordance with EN 60715
Mounting position	Any
Width	6.2 mm
Height	80 mm
Depth	86 mm
Type of housing	Polyamide PA, self-extinguishing
Color	green
Connection data Screw connection	
Conductor cross section, solid	0.14 mm ² ... 2.5 mm ²
Conductor cross section, stranded	0.14 mm ² ... 2.5 mm ²
AWG	30 ... 12
Stripping length	8 mm
Tightening torque	0.6 Nm ... 0.8 Nm / 5 lb in ... 7 lb in
Connection data Spring-cage conn.	
Conductor cross section, solid	0.14 mm ² ... 2.5 mm ²
Conductor cross section, stranded	0.14 mm ² ... 2.5 mm ²
AWG	26 ... 12
Stripping length	8 mm
Connection data Push-in conn.	
Conductor cross section, solid	0.14 mm ² ... 2.5 mm ²
Conductor cross section, stranded	0.14 mm ² ... 2.5 mm ²
AWG	26 ... 14
Stripping length	8 mm
Ambient conditions	
Ambient temperature (operation)	-20 °C ... 65 °C
Ambient temperature (storage/transport)	-25 °C ... 80 °C
Permissible humidity (operation)	15 % ... 85 %
Conformance / approvals	
Conformance	CE-compliant
ATEX	Ⓜ II 3 G Ex nA nC IIC T4 Gc X
UL, USA / Canada	UL/C-UL listed UL 508
GL (not for ETD-BL-...-PT)	GL EMC 1 C

Conformance with EMC Directive 2004/108/EC

Noise immunity
When being exposed to interference, there may be minimal deviations. EN 61000-6-2

Noise emission EN 61000-6-4

Conformance with LV directive 2006/95/EC

Electronic equipm. for electrical power installations according to EN 50178

4 Block diagram

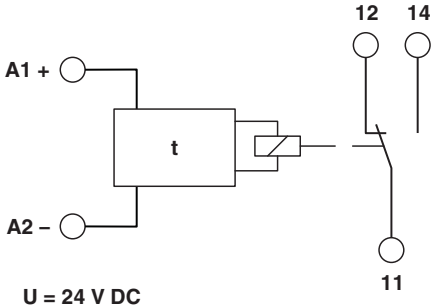

5 Safety regulations and installation notes



WARNING: Risk of electric shock

Never carry out work when voltage is present.

Installation notes



The category 3 device is suitable for installation in the zone 2 potentially explosive area. It fulfills the requirements of EN 60079-0:2009 and EN 60079-15:2010.



NOTE: Installation, operation and maintenance may be carried out only by qualified electricians. Follow the specified installation instructions. When installing and operating the device, the applicable safety directives (including national safety directives), accident prevention regulations, as well as general technical regulations, must be observed. The technical data should be taken from this data sheet and the certificates (conformity assessment, other possible approvals).



NOTE: Do not open the device or make changes to it. Do not repair the device yourself, replace it with an equivalent device. Repairs may only be carried out by the manufacturer. The manufacturer is not liable for any damage due to violation of the described regulations.



NOTE: The IP20 degree of protection (IEC 60529/EN 60529) of the device is intended for a clean and dry environment. Do not subject the device to any load that exceeds the described limits.



WARNING: Explosion hazard

The device has not been designed for use in potentially dust-explosive atmospheres.

Installation in Ex area (zone 2)



NOTE: Please observe the requirements defined for use in potentially explosive atmospheres!



WARNING: Explosion hazard

The device should be installed in a housing (control or distributor box) that fulfills the requirements of EN 60079-15 and at least IP54 (EN 60529) degree of protection.



WARNING: Explosion hazard

When installing and connecting the supply and signal circuits observe the requirements of EN 60079-14. Only devices suitable for operation in Ex zone 2 and the conditions at the application site may be connected to the circuits in zone 2.



WARNING: Explosion hazard

Cables may be connected and disconnected in potentially explosive areas only when power is disconnected.



WARNING: Explosion hazard

The device must be stopped and immediately removed from the Ex area if it is damaged or was subject to an impermissible load or stored incorrectly or if it malfunctions.



You can download the latest documents at www.phoenixcontact.net/products.

6 Structure

- 1 Knurled wheel for setting the time
- 2 LED U/t (green): Supply voltage and adjustable time
- 3 LED R (yellow): Output relay

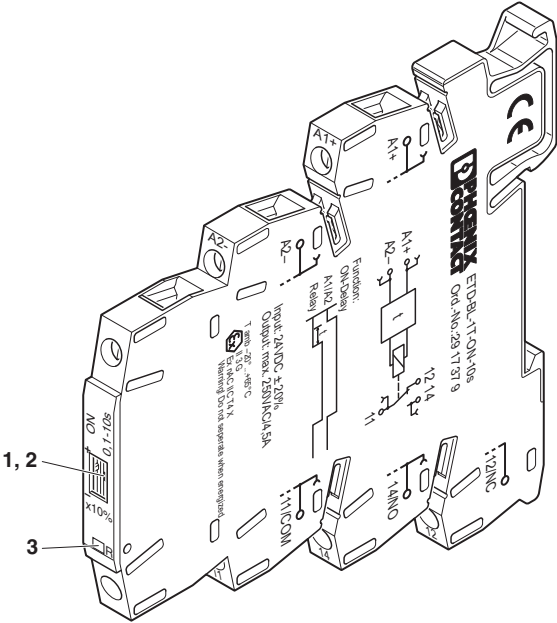

7 Installation



WARNING: Risk of electric shock
 Never carry out work when voltage is present.

The module can be snapped onto all 35 mm DIN rails according to EN 60715.

UL requirement: Use copper cables approved for at least 75°C.

Power supply

The module is supplied with 24 V of DC voltage.

8 Time setting

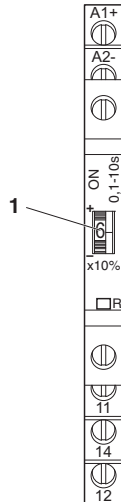

The time can be adjusted variably using a screwdriver (blade width 2.5 mm). The value set on the knurled wheel multiplied by 10 gives the percentage set value of the time end value.

Example:

Time end range of the time relay = 10 s

- 1 Setting on the knurled wheel = 6 $6 \times 10 \% = 60 \%$
 Time end range of the time relay = 10 s 60% of 10 s = 6 s

According to the setting of the knurled wheel (1...10), you can also read the time directly from the "Time setting for different time setting ranges" table.

Time settings for various time setting ranges:

Position Knurled wheel	0.1 - 10 s time [seconds]	3 - 300 s time [seconds]	0.3 - 30 min time [minutes]	3 - 300 min time [minutes]
0	0,1	3	0,3	3
1	1	30	3	30
2	2	60	6	60
3	3	90	9	90
4	4	120	12	120
5	5	150	15	150
6	6	180	18	180
7	7	210	21	210
8	8	240	24	240
9	9	270	27	270
10	10	300	30	300



The following table shows some examples: All intermediate values (e. g. 1.5) can be adjusted. The smallest adjustable time is reached at position "0". No time can be set between "10" and "0". This area is identified with a quickly flashing geed LED.

9 Diagnostics

The LEDs indicate the following error states:

LED U/t (green, backlighting of the knurled wheel)

- Flashes: Voltage is present, the set time is elapsing
- Flashing quickly: Undefined time range between "10" and "0" adjusted
- On: Voltage is present, the set time has elapsed

LED R (yellow)

- On: The output relay has picked up
- Off: The output relay is dropped

10 Connection example

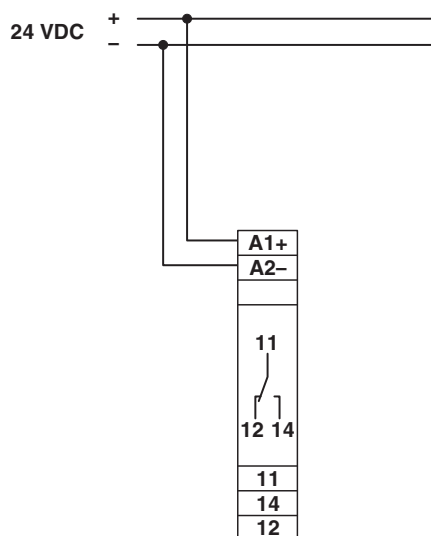

11 Function

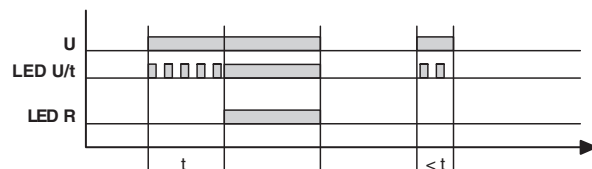

ON: With switch-on delay

When supply voltage U is applied, the set time t starts running (green LED U/t flashes). After time t has elapsed (green LED U/t lights up), the output relay picks up (yellow LED R lights up). This state remains until the supply voltage U is interrupted. If supply voltage U is interrupted before time t elapses, the already elapsed time is deleted (relay does not pick up). The time is restarted the next time the supply voltage U is applied.

Компания «Life Electronics» занимается поставками электронных компонентов импортного и отечественного производства от производителей и со складов крупных дистрибьюторов Европы, Америки и Азии.

С конца 2013 года компания активно расширяет линейку поставок компонентов по направлению коаксиальный кабель, кварцевые генераторы и конденсаторы (керамические, пленочные, электролитические), за счёт заключения дистрибьюторских договоров

Мы предлагаем:

- Конкурентоспособные цены и скидки постоянным клиентам.
- Специальные условия для постоянных клиентов.
- Подбор аналогов.
- Поставку компонентов в любых объемах, удовлетворяющих вашим потребностям.
- Приемлемые сроки поставки, возможна ускоренная поставка.
- Доставку товара в любую точку России и стран СНГ.
- Комплексную поставку.
- Работу по проектам и поставку образцов.
- Формирование склада под заказчика.
- Сертификаты соответствия на поставляемую продукцию (по желанию клиента).
- Тестирование поставляемой продукции.
- Поставку компонентов, требующих военную и космическую приемку.
- Входной контроль качества.
- Наличие сертификата ISO.

В составе нашей компании организован Конструкторский отдел, призванный помогать разработчикам, и инженерам.

Конструкторский отдел помогает осуществить:

- Регистрацию проекта у производителя компонентов.
- Техническую поддержку проекта.
- Защиту от снятия компонента с производства.
- Оценку стоимости проекта по компонентам.
- Изготовление тестовой платы монтаж и пусконаладочные работы.



Тел: +7 (812) 336 43 04 (многоканальный)

Email: org@lifeelectronics.ru