

LGA C Series

15-100 Watts

Total Power: 15-100 Watts
No. of Outputs: Single

Special Features

- 3,6,10,15 and 20 A output current rating
- Wide input voltage range; up to 14 V
- Adjustable output voltage; 0.59-5.1 V
- Excellent transient response
- High efficiency
- Output margining
- Power enable
- Minimal airflow requirement
- Termination voltage capability
- Ultra compact profile and footprint
- RoHS compliant
- Remote sense
- Termination voltage capability

Safety

Designed to meet EN60950

International Standards for
Solderability: J-STD-002B
IEC-60068-2-58



Electrical Specifications

Output		3/6/10 A Models	15/20 A Model
Output voltage	See Page 3	0.59-5.1 V	
Output setpoint accuracy	0.1% trim resistors	±1.0%	
Line regulation		±0.2%	
Load regulation		±0.5%	
Max Current Max Power		15/30/50 W	75/100 W
Overshoot	At turn-on	0%	
Undershoot	At turn-off	0 mV	
Ripple and noise 5 Hz to 20 MHz	See Note 1 $V_{in} = 5 V, V_{out} = 2.5 V$	20/25/30 mV	20/30 mV
Transient response	See Notes 1 and 2 $V_{in} = 5 V, V_{out} = 2.5 V$	100/160/160 mV 15 μ s recovery to within regulation band	160/175 mV 15 μ s recovery to within regulation band
Input			
Input voltage range ³		3-14 Vdc	4.5-14 Vdc
Input current	Enable On at (0 A) Enable Off	50 mA 5 mA	
Start-up time	Power up Enable On/Off	3 ms 2 ms	
General			
Efficiency	$V_{in}=5 V_{out}, V_o=2.5 V,$ $I_{out} = 50\% I_{max}$	92% typ.	93/92% typ.
Switching frequency		1 MHz	800 kHz
Material flammability		UL94V-0	
MTBF	12 V @ 40 °C 100% load Bellcore 332	> 20,000,000 hours	
Coplanarity		150 μ m	

Electrical Specifications (cont'd)

Thermal performance See Technical Reference Note	Operating ambient Non-operating ambient	-40 °C to +85 °C -40 °C to +125 °C
---	--	---------------------------------------

Protection

Short circuit	Hiccup, non-latching
Overvoltage	Hiccup, non-latching

Minimum Recommended System Capacitance	3/6/10 A Model	20 A Model
Input capacitance	1 µF	10 µF
Output capacitance	10 µF	50 µF

Operating Information

Output Power (Max.)	Input Voltage	Output Voltage	Output Current (Min.)	Output Current (Max.)	Efficiency (Typical)	Regulation Line	Regulation Load	Standard Model Numbers
15 W	3-14.0 Vdc	0.59-5.1 Vdc	0 A	3 A	92%	±0.2%	±0.5%	LGA03C-00SADJJ
30 W	3-14.0 Vdc	0.59-5.1 Vdc	0 A	6 A	92%	±0.2%	±0.5%	LGA06C-00SADJJ
50 W	3-14.0 Vdc	0.59-5.1 Vdc	0 A	10 A	92%	±0.2%	±0.5%	LGA10C-00SADJJ
75 W	4.5-14.0 Vdc	0.59-5.1 Vdc	0 A	15 A	93%	±0.2%	±0.5%	LGA15C-01SADJJ
100 W	4.5-14.0 Vdc	0.59-5.1 Vdc	0 A	20 A	91%	±0.2%	±0.5%	LGA20C-01SADJJ

Model Number System with Options



Product Family	Rated Output Current	Performance	Input Voltage	Type of Output	Options	RoHS Compliance
LGA	XX	C	- 00	SADJ	X	J
	Rated Output Current 03 = 3 Amp 06 = 6 Amp 10 = 10 Amp 15 = 15 Amp 20 = 20 Amp	Performance C = Cost Optimized	Input Voltage 00 = 3-14.0 V 01 = 4.5-14.0 V	Type of Output Single Adjustable Output	Options X = Various Options (see Sales Rep)	RoHS Compliance J = Pb free (RoHS 6/6 compliant)

Heatsink Number System with Options



Product Family	Product	Purpose	Height*
LGA	- HTSK	- KIT	- XXX
Land Grid Array	Heatsink	Heatsink and Adhesive	Total Height (LGA20 + Heatsink) 045 = 0.45" 048 = 0.48" 050 = 0.50"

*Height is the total height of the LGA20C-00SADJJ with heatsink attached.

Application Equations

Setting Output Voltage

Default output voltage: 0.591 V

The output voltage may be adjusted with a resistor placed between the "Trim" and "-Sense" pin.

The formula for calculating the value of this resistor is:

$$R_{\text{trim}}(\text{k}\Omega) = \frac{1.182}{V_{\text{out}} - 0.591}$$

See Technical Reference Note for other trimming methods.

Setting Under Voltage Lock Out - 3, 6, 10 A Models

Default Turn-on voltage: 2.9 V (300 mV Hysteresis)

The Turn-on voltage may be adjusted with a resistor placed between the "Enable" and "Ground" pins.

The formula for calculating the value of this resistor is:

$$R_{\text{UVlo}}(\text{k}\Omega) = \frac{14.81 * 6.81}{(6.81 * V_{\text{Turn_on}}) - 18.16}$$

*** ONLY USE WITH OPEN COLLECTOR DEVICE**
*** DO NOT DRIVE PIN WITH A VOLTAGE**

Setting Under Voltage Lock Out - 15 and 20 A Models

Default Turn-on voltage: 4.3 V (300 mV Hysteresis)

The Turn-on voltage may be adjusted with a resistor placed between the "Enable" and "Ground" pins.

The formula for calculating the value of this resistor is:

$$R_{\text{UVlo}}(\text{k}\Omega) = \frac{30.1 * 4.22}{(8.577 * V_{\text{Turn_on}}) - 34.32}$$

*** ONLY USE WITH OPEN COLLECTOR DEVICE**
*** DO NOT DRIVE PIN WITH A VOLTAGE**

Setting Margin Control

To margin the output up, pull the margin control pin high. To margin down, pull the margin control pin low. If the pin is left floating, the feature is disabled. The maximum margining range is $\pm 33\%$ of the output default voltage setting, with maximum output at 5.5 V

$$V_{\text{margin_up}} = 0.1182 * \frac{R_{\text{margin}}}{R_{\text{ofs+}}} * \frac{R_{\text{trim}} + 2\text{k}}{R_{\text{trim}}}$$

$$V_{\text{margin_down}} = 0.1182 * \frac{R_{\text{margin}}}{R_{\text{ofs-}}} * \frac{R_{\text{trim}} + 2\text{k}}{R_{\text{trim}}}$$

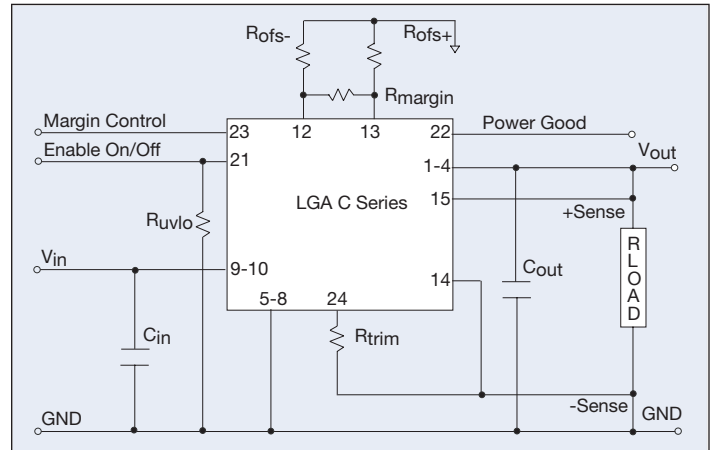

External input fusing is recommended.

Notes:

1. Measured as per recommended minimum system capacitance.
2. $di/dt = 10 \text{ A}/\mu\text{s}$, $12 \text{ Vin} = \text{Norm}$, $T_c = 25^\circ\text{C}$, load change = 50% to 100% I_{max} .
3. Internal input capacitance is rated 16 Vdc maximum.

Mechanical Drawing and Footprint

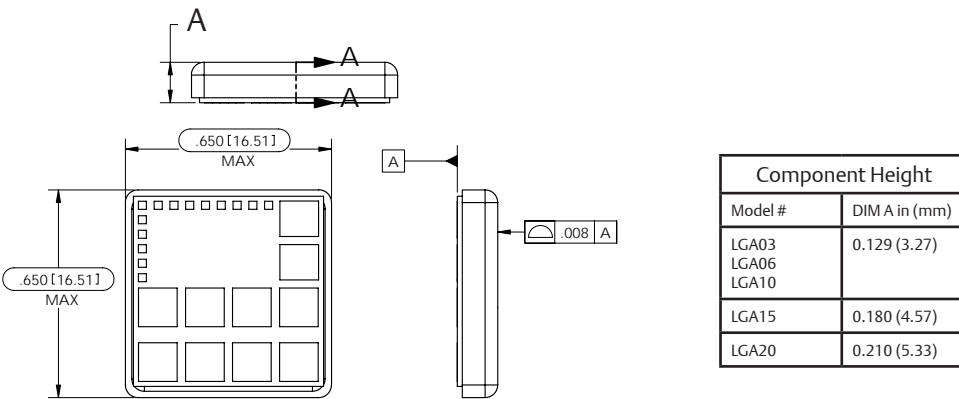

Recommended System Board Footprint

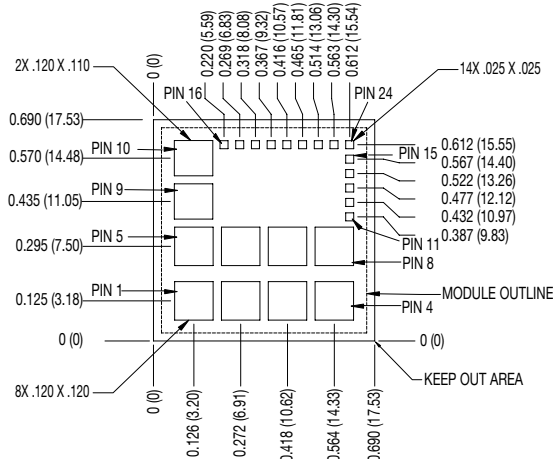

Tolerance Note: ± 0.010 (0.25)

Recommended Solder Paste Stencil

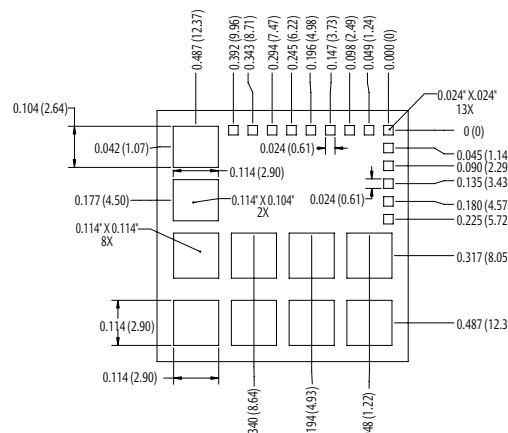

Pin Assignments

Single Output

1	Vout
2	Vout
3	Vout
4	Vout
5	GND
6	GND
7	GND
8	GND
9	Vin
10	Vin
11	NC
12	- Offset
13	+ Offset
14	- Sense
15	+ Sense
16	NC
17	NC
18	NC
19	NC
20	NC
21	Enable
22	Power Good
23	Margin Control
24	Trim

Americas

5810 Van Allen Way
Carlsbad, CA 92008
USA
Telephone: +1 760 930 4600
Facsimile: +1 760 930 0698

Europe (UK)

Waterfront Business Park
Merry Hill, Dudley
West Midlands, DY5 1LX
United Kingdom
Telephone: +44 (0) 1384 842 211
Facsimile: +44 (0) 1384 843 355

Asia (HK)

14/F, Lu Plaza
2 Wing Yip Street
Kwun Tong, Kowloon
Hong Kong
Telephone: +852 2176 3333
Facsimile: +852 2176 3888

For global contact, visit:

www.Emerson.com/EmbeddedPower
techsupport.embeddedpower@emerson.com

While every precaution has been taken to ensure accuracy and completeness in this literature, Emerson Network Power assumes no responsibility, and disclaims all liability for damages resulting from use of this information or for any errors or omissions.

Emerson Network Power.

The global leader in enabling
business-critical continuity.

- AC Power
- Connectivity
- DC Power
- Embedded Computing
- Embedded Power
- Monitoring
- Outside Plant
- Power Switching & Controls
- Precision Cooling
- Racks & Integrated Cabinets
- Services
- Surge Protection

EmersonNetworkPower.com

Emerson Network Power and the Emerson Network Power logo are trademarks and service marks of Emerson Electric Co.
©2011 Emerson Electric Co.

Компания «Life Electronics» занимается поставками электронных компонентов импортного и отечественного производства от производителей и со складов крупных дистрибьюторов Европы, Америки и Азии.

С конца 2013 года компания активно расширяет линейку поставок компонентов по направлению коаксиальный кабель, кварцевые генераторы и конденсаторы (керамические, пленочные, электролитические), за счёт заключения дистрибьюторских договоров

Мы предлагаем:

- Конкурентоспособные цены и скидки постоянным клиентам.
- Специальные условия для постоянных клиентов.
- Подбор аналогов.
- Поставку компонентов в любых объемах, удовлетворяющих вашим потребностям.
- Приемлемые сроки поставки, возможна ускоренная поставка.
- Доставку товара в любую точку России и стран СНГ.
- Комплексную поставку.
- Работу по проектам и поставку образцов.
- Формирование склада под заказчика.
- Сертификаты соответствия на поставляемую продукцию (по желанию клиента).
- Тестирование поставляемой продукции.
- Поставку компонентов, требующих военную и космическую приемку.
- Входной контроль качества.
- Наличие сертификата ISO.

В составе нашей компании организован Конструкторский отдел, призванный помогать разработчикам, и инженерам.

Конструкторский отдел помогает осуществить:

- Регистрацию проекта у производителя компонентов.
- Техническую поддержку проекта.
- Защиту от снятия компонента с производства.
- Оценку стоимости проекта по компонентам.
- Изготовление тестовой платы монтаж и пусконаладочные работы.



Тел: +7 (812) 336 43 04 (многоканальный)

Email: org@lifeelectronics.ru