

REVISIONS				
P	LTN	DESCRIPTION	DATE	APVD
V		REDRAWN /REVISED PER ECO-17-001745	22NOV2017	KS JO

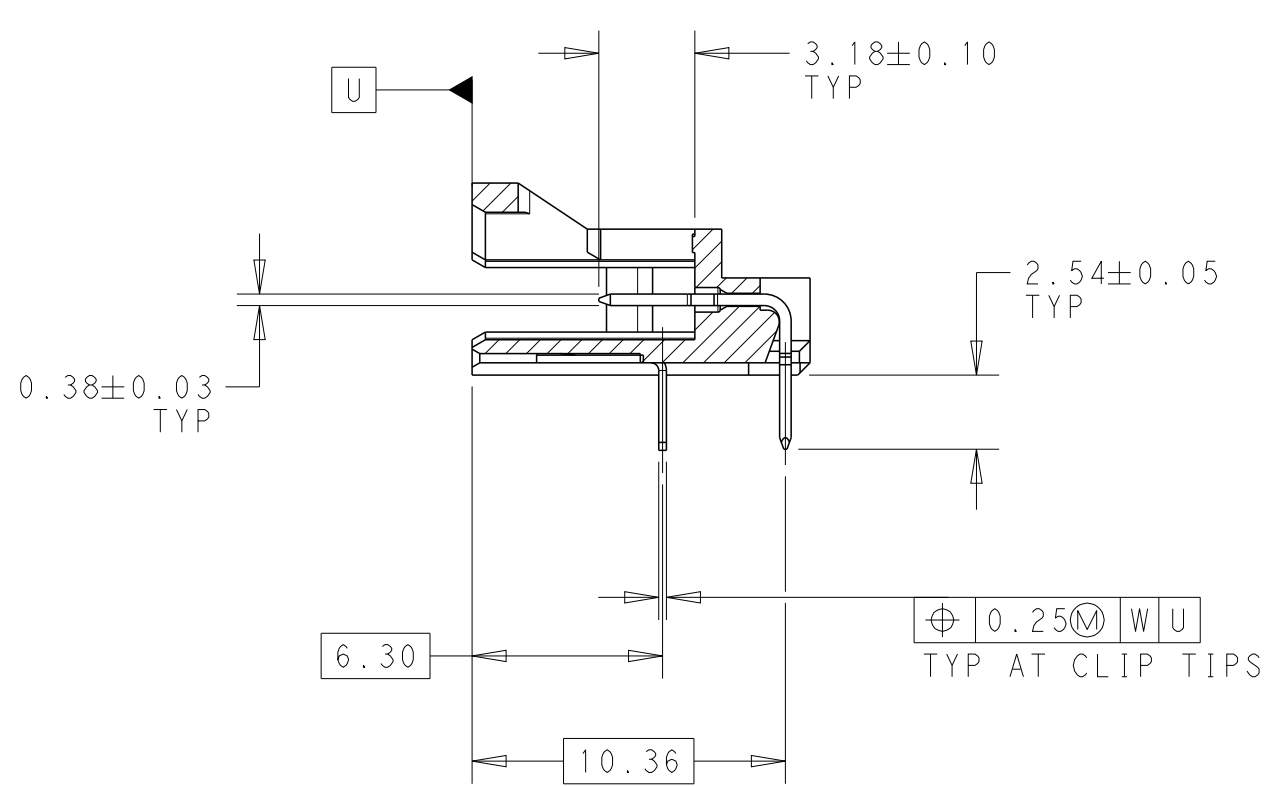

- △ CONTACT AREAS PLATED WITH 0.76µm GOLD, SOLDER TAILS PLATED WITH 3.81µm TIN-LEAD, ALL OVER 1.27µm NICKEL
- 2. NOTE DELETED.
- △ CIRCUIT IDENTIFICATION FEATURE OMITTED ON 4, 5, 6, & 7 POSITION HEADER ASSEMBLIES
- △ DIMENSION APPLIES AT BASE OF SHROUD
- △ THE NOTED DIMENSIONS APPLY AT THE INTERSECTION OF THE POST AND HOUSING
- △ CONTACT AREAS PLATED WITH 0.76µm GOLD, SOLDER TAILS PLATED WITH 3.81µm TIN, ALL OVER 1.27µm NICKEL.
- △ MATERIAL: HOUSING-LCP, COLOR-BLACK  
CONTACT-COPPER ALLOY
- △ FINISH: 0.03µm MIN GOLD ON GOLD PLATED AREA, 3.81µm MATTE TIN-LEAD ON TIN PLATED AREA. UNDER PLATING TO BE 1.27µm NICKEL ON ENTIRE CONTACT
- △ FINISH: 0.03µm MIN GOLD ON GOLD PLATED AREA, 3.81µm MATTE TIN ON TIN PLATED AREA. UNDER PLATING TO BE 1.27µm NICKEL ON ENTIRE CONTACT.
- 10. NOTE DELETED.
- 11. NOTE DELETED.
- 12. NOTE DELETED.
- 13. NOTE DELETED.

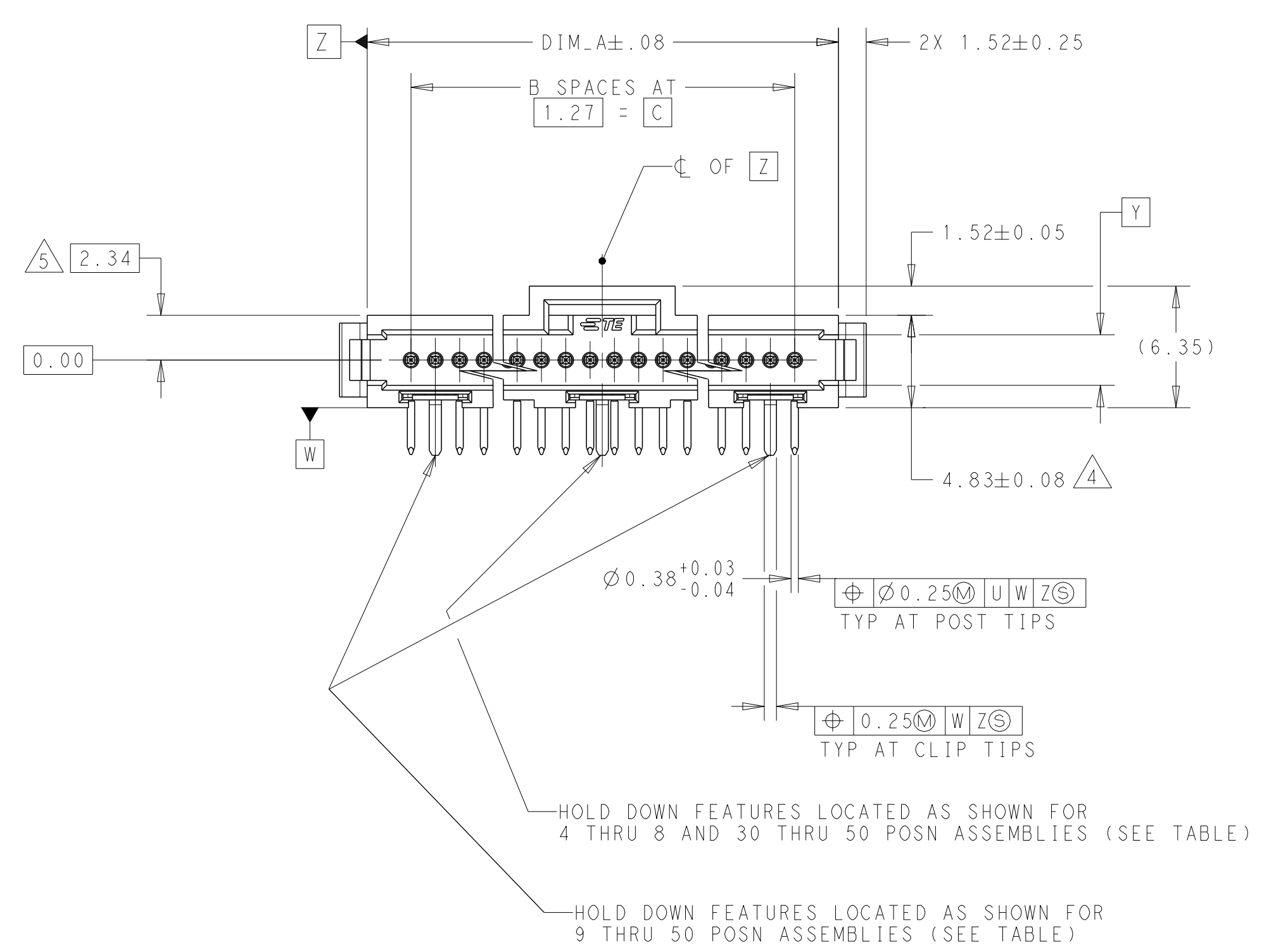
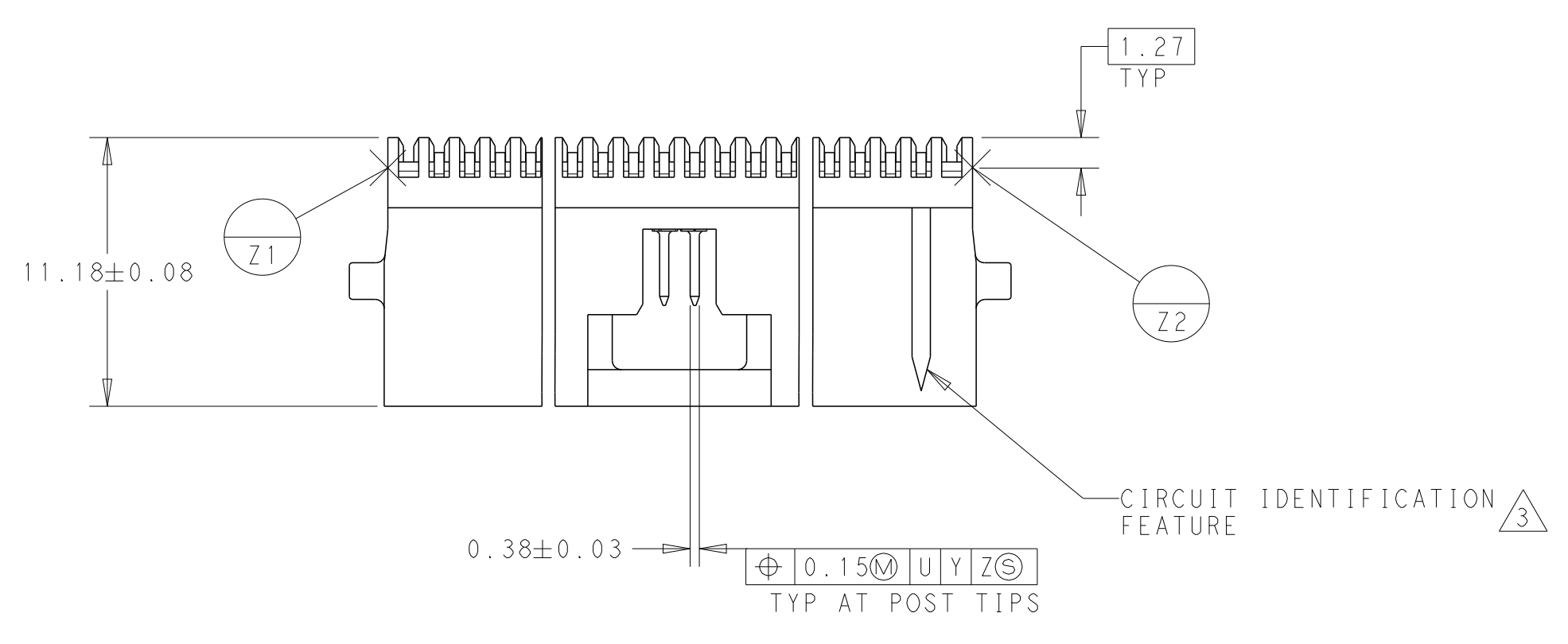
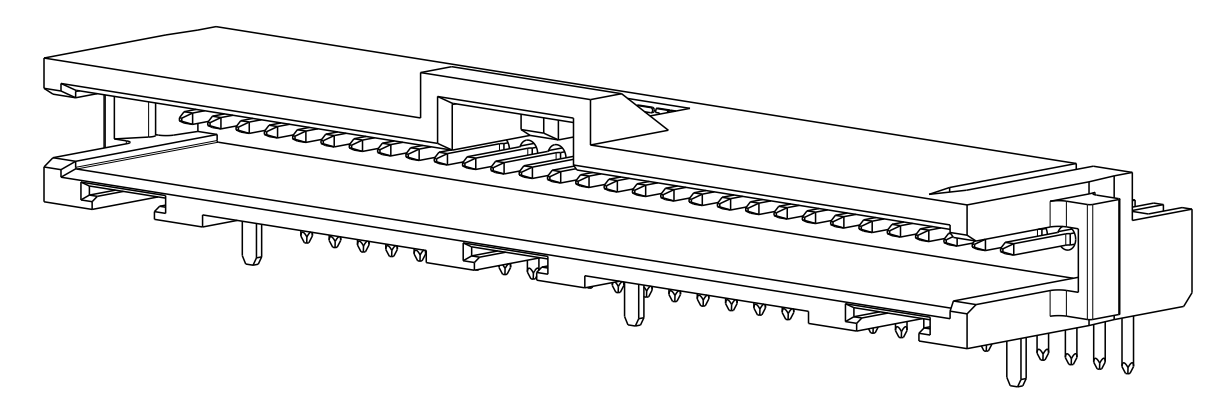
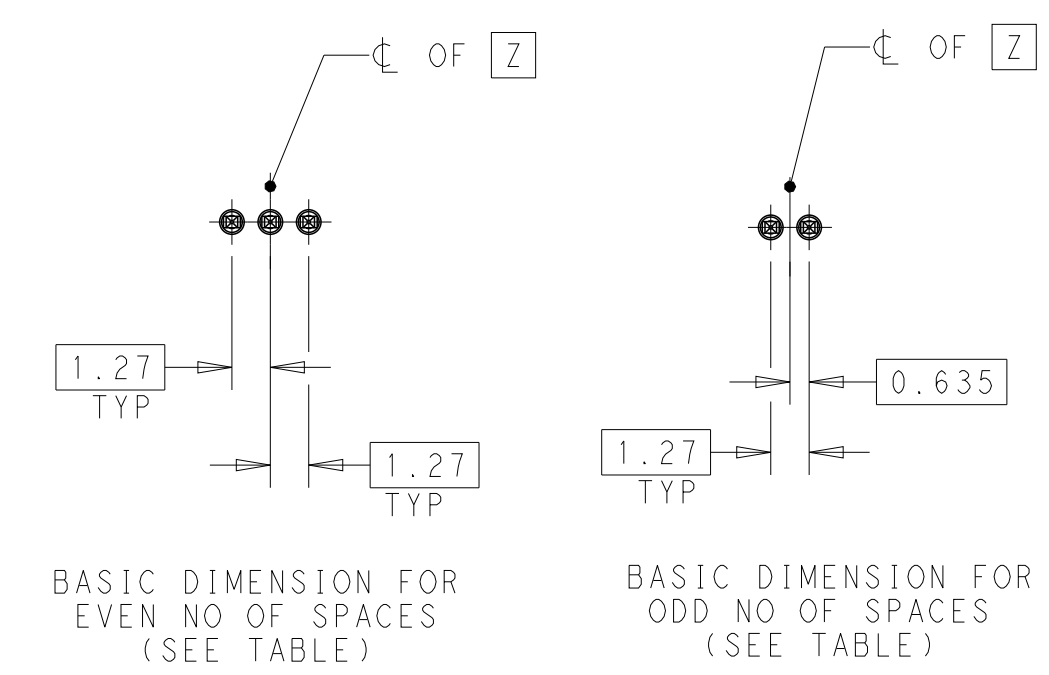
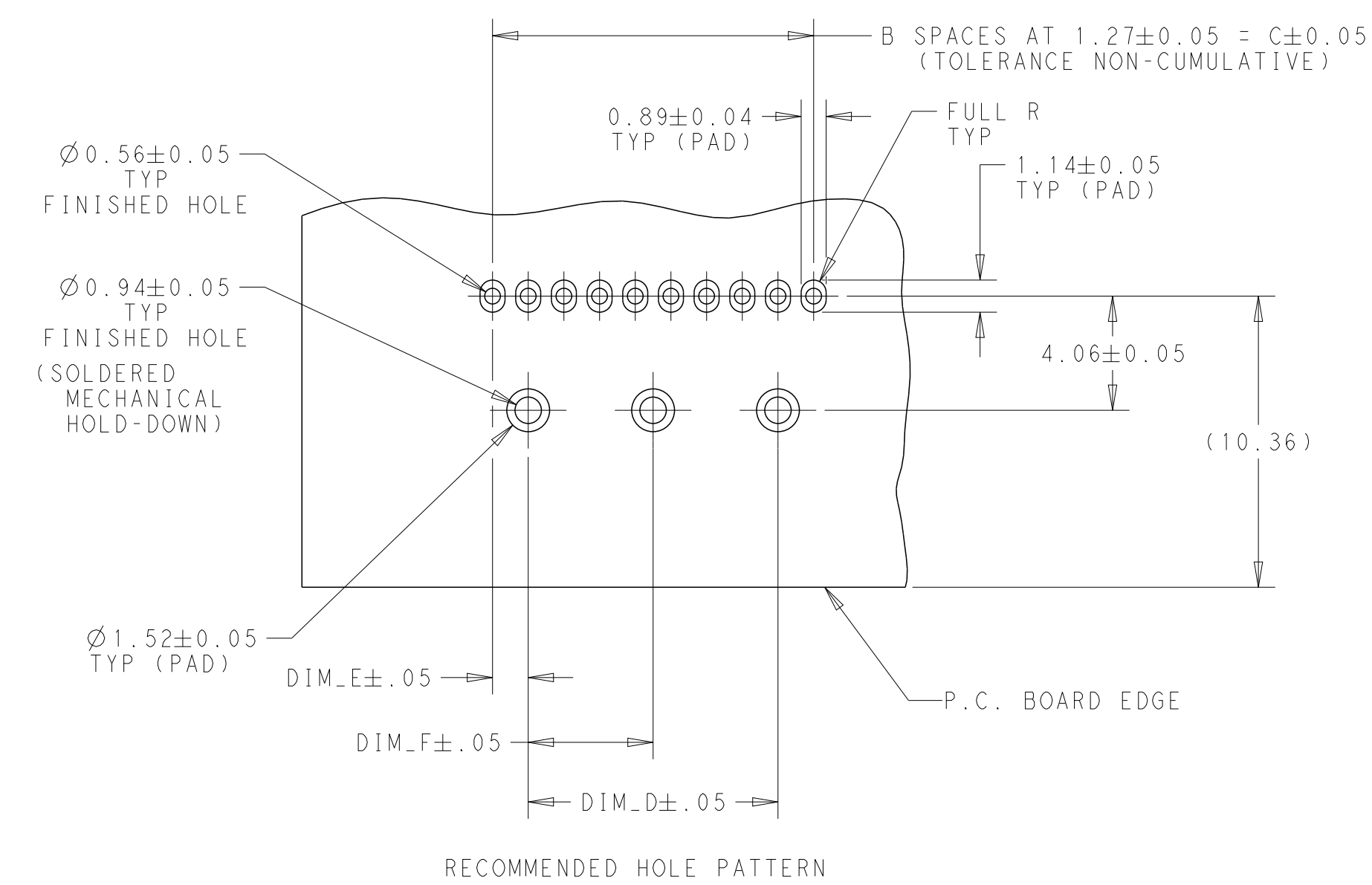

THIS DRAWING IS A CONTROLLED DOCUMENT.		OWN: R. SHRISHAIL 22NOV2017	TE Connectivity
DIMENSIONS: mm		CHK: J. OLSON 22NOV2017	
TOLERANCES UNLESS OTHERWISE SPECIFIED:		APVD: J. OLSON 22NOV2017	NAME: HEADER ASSEMBLY, RIGHT ANGLE, SINGLE ROW, W/SIDE & END LATCHES, AMPMODU SYSTEM 50
0 PLC	±	PRODUCT SPEC	SIZE: 108-1093
1 PLC	±0.3	APPLICATION SPEC	CAGE CODE: 114-25031
2 PLC	±0.13	WEIGHT	DRAWING NO: C=104074
3 PLC	±	RESTRICTED TO	SCALE: 4:1
4 PLC	±		SHEET 1 OF 2
ANGLES	±0.5°		REV V
FINISH	SEE TABLE	CUSTOMER DRAWING	

REVISIONS				
P	LTN	DESCRIPTION	DATE	APPV
-		SEE SHEET 1	-	-

	15.87	1.27	31.75	34.29	27	38.86	28	9-104074-0
	29.84	1.27	59.69	62.23	49	66.80	50	8-104074-9
	26.67	1.27	53.34	55.88	44	60.45	45	8-104074-8
	23.49	1.27	46.99	49.53	39	54.10	40	8-104074-7
	20.95	1.27	41.91	44.45	35	49.02	36	8-104074-6
	15.24	1.27	30.48	33.02	26	37.59	27	8-104074-5
	-	1.27	24.13	26.67	21	31.24	22	8-104074-4
	-	1.27	17.78	20.32	16	24.89	17	8-104074-3
	-	1.27	12.70	15.24	12	19.81	13	8-104074-2
	-	1.27	11.43	13.97	11	18.54	12	8-104074-1
	-	4.44	-	8.89	7	13.46	8	8-104074-0
	-	3.81	-	7.62	6	12.19	7	7-104074-9
	-	3.17	-	6.35	5	10.92	6	7-104074-8
	-	1.90	-	3.81	3	8.38	4	7-104074-7
	17.14	1.27	34.29	36.83	29	41.40	30	7-104074-6
	-	1.27	27.94	30.48	24	35.05	25	7-104074-5
	-	1.27	21.59	24.13	19	28.70	20	7-104074-4
	-	1.27	15.24	17.78	14	22.35	15	7-104074-3
	-	2.54	-	5.08	4	9.65	5	7-104074-2
	-	1.27	8.89	11.43	9	16.00	10	7-104074-1
	15.87	1.27	31.75	34.29	27	38.86	28	7-104074-0
	29.84	1.27	59.69	62.23	49	66.80	50	6-104074-9
	26.67	1.27	53.34	55.88	44	60.45	45	6-104074-8
	23.49	1.27	46.99	49.53	39	54.10	40	6-104074-7
	20.95	1.27	41.91	44.45	35	49.02	36	6-104074-6
	15.24	1.27	30.48	33.02	26	37.59	27	6-104074-5
	-	1.27	24.13	26.67	21	31.24	22	6-104074-4
	-	1.27	17.78	20.32	16	24.89	17	6-104074-3
	-	1.27	12.70	15.24	12	19.81	13	6-104074-2
	-	1.27	11.43	13.97	11	18.54	12	6-104074-1
	-	4.44	-	8.89	7	13.46	8	6-104074-0
	-	3.81	-	7.62	6	12.19	7	5-104074-9
	-	3.17	-	6.35	5	10.92	6	5-104074-8
	-	1.90	-	3.81	3	8.38	4	5-104074-7
	17.14	1.27	34.29	36.83	29	41.40	30	5-104074-6
	-	1.27	27.94	30.48	24	35.05	25	5-104074-5
	-	1.27	21.59	24.13	19	28.70	20	5-104074-4
	-	1.27	15.24	17.78	14	22.35	15	5-104074-3
	-	2.54	-	5.08	4	9.65	5	5-104074-2
	-	1.27	8.89	11.43	9	16.00	10	5-104074-1
FINSH	DIM_F	DIM_E	DIM_D	DIM_C	<sup>B</sup> SPACES	DIM_A	NO OF POSN	PART NUMBER

	15.87	1.27	31.75	34.29	27	38.86	28	4-104074-0
	29.84	1.27	59.69	62.23	49	66.80	50	3-104074-9
	26.67	1.27	53.34	55.88	44	60.45	45	3-104074-8
	23.49	1.27	46.99	49.53	39	54.10	40	3-104074-7
	20.95	1.27	41.91	44.45	35	49.02	36	3-104074-6
	15.24	1.27	30.48	33.02	26	37.59	27	3-104074-5
	-	1.27	24.13	26.67	21	31.24	22	3-104074-4
	-	1.27	17.78	20.32	16	24.89	17	3-104074-3
	-	1.27	12.70	15.24	12	19.81	13	3-104074-2
	-	1.27	11.43	13.97	11	18.54	12	3-104074-1
	-	4.44	-	8.89	7	13.46	8	3-104074-0
	-	3.81	-	7.62	6	12.19	7	2-104074-9
	-	3.17	-	6.35	5	10.92	6	2-104074-8
	-	1.90	-	3.81	3	8.38	4	2-104074-7
	17.14	1.27	34.29	36.83	29	41.40	30	2-104074-6
	-	1.27	27.94	30.48	24	35.05	25	2-104074-5
	-	1.27	21.59	24.13	19	28.70	20	2-104074-4
	-	1.27	15.24	17.78	14	22.35	15	2-104074-3
	-	2.54	-	5.08	4	9.65	5	2-104074-2
	-	1.27	8.89	11.43	9	16.00	10	2-104074-1
	15.87	1.27	31.75	34.29	27	38.86	28	2-104074-0
	29.84	1.27	59.69	62.23	49	66.8	50	1-104074-9
	26.67	1.27	53.34	55.88	44	60.45	45	1-104074-8
	23.49	1.27	46.99	49.53	39	54.10	40	1-104074-7
	20.95	1.27	41.91	44.45	35	49.02	36	1-104074-6
	15.24	1.27	30.48	33.02	26	37.59	27	1-104074-5
	-	1.27	24.13	26.67	21	31.24	22	1-104074-4
	-	1.27	17.78	20.32	16	24.89	17	1-104074-3
	-	1.27	12.70	15.24	12	19.81	13	1-104074-2
	-	1.27	11.43	13.97	11	18.54	12	1-104074-1
	-	4.44	-	8.89	7	13.46	8	1-104074-0
	-	3.81	-	7.62	6	12.19	7	104074-9
	-	3.17	-	6.35	5	10.92	6	104074-8
	-	1.90	-	3.81	3	8.38	4	104074-7
	17.14	1.27	34.29	36.83	29	41.40	30	104074-6
	-	1.27	27.94	30.48	24	35.05	25	104074-5
	-	1.27	21.59	24.13	19	28.70	20	104074-4
	-	1.27	15.24	17.78	14	22.35	15	104074-3
	-	2.54	-	5.08	4	9.65	5	104074-2
	-	1.27	8.89	11.43	9	16.00	10	104074-1
FINSH	DIM_F	DIM_E	DIM_D	DIM_C	<sup>B</sup> SPACES	DIM_A	NO OF POSN	PART NUMBER

THIS DRAWING IS A CONTROLLED DOCUMENT. DWN R. SHRISHAI 22NOV2017  
 CHK J. OLSON 22NOV2017

DIMENSIONS: mm TOLERANCES UNLESS OTHERWISE SPECIFIED:  
 0 PLC ±  
 1 PLC ±0.3  
 2 PLC ±0.13  
 3 PLC ±  
 4 PLC ±  
 ANGLES ±0.5°  
 FINISH SEE TABLE

MATERIAL WEIGHT 114-25031

CUSTOMER DRAWING

APVD J. OLSON 22NOV2017  
 PRODUCT SPEC 108-1093  
 APPLICATION SPEC

NAME HEADER ASSEMBLY, RIGHT ANGLE, SINGLE ROW, W/SIDE & END LATCHES AMPMODU SYSTEM 50

SIZE A1 CAGE CODE - DRAWING NO. 104074 RESTRICTED TO

SCALE 4:1 SHEET 2 OF 2 REV V



Компания «Life Electronics» занимается поставками электронных компонентов импортного и отечественного производства от производителей и со складов крупных дистрибьюторов Европы, Америки и Азии.

С конца 2013 года компания активно расширяет линейку поставок компонентов по направлению коаксиальный кабель, кварцевые генераторы и конденсаторы (керамические, пленочные, электролитические), за счёт заключения дистрибьюторских договоров

Мы предлагаем:

- Конкуренеспособные цены и скидки постоянным клиентам.
- Специальные условия для постоянных клиентов.
- Подбор аналогов.
- Поставку компонентов в любых объемах, удовлетворяющих вашим потребностям.
- Приемлемые сроки поставки, возможна ускоренная поставка.
- Доставку товара в любую точку России и стран СНГ.
- Комплексную поставку.
- Работу по проектам и поставку образцов.
- Формирование склада под заказчика.
- Сертификаты соответствия на поставляемую продукцию (по желанию клиента).
- Тестирование поставляемой продукции.
- Поставку компонентов, требующих военную и космическую приемку.
- Входной контроль качества.
- Наличие сертификата ISO.

В составе нашей компании организован Конструкторский отдел, призванный помогать разработчикам, и инженерам.

Конструкторский отдел помогает осуществить:

- Регистрацию проекта у производителя компонентов.
- Техническую поддержку проекта.
- Защиту от снятия компонента с производства.
- Оценку стоимости проекта по компонентам.
- Изготовление тестовой платы монтаж и пусконаладочные работы.



Тел: +7 (812) 336 43 04 (многоканальный)  
Email: [org@lifeelectronics.ru](mailto:org@lifeelectronics.ru)