



SANYO Semiconductors

DATA SHEET

An ON Semiconductor Company

LB1962MC

Monolithic Digital IC

For Fan Motor

Single-Phase Full-Wave Driver

Overview

Single-phase full-wave drive design and a compact package make these ICs optimal for small fans (especially CPU cooling fans). Low switching noise and effective motor drive are further advantages.

Functions

- Support for 5V/12V dual power supply voltage
- Built-in regenerative circuit allows use of reverse connection protection diode
- Built-in Hall amplifier with hysteresis (supports core without auxiliary electrode)
- Built-in lockup protection and automatic recovery circuits
- Rotation detection output (FG)
- Hall bias pin and start/stop pin allow reduced current drain in standby mode
- Built-in thermal protection circuit

Specifications

Absolute Maximum Ratings at Ta = 25°C

Parameter	Symbol	Conditions	Ratings	Unit
Maximum supply voltage	V _{CC} max		17	V
Maximum output current	I _{OUT} max		0.5	A
Maximum output withstand voltage	V _{OUT} max		17	V
FG maximum output withstand voltage	V _{FG} max		17	V
FG maximum output current	I _{FG} max		5	mA
HB maximum output current	I _B max		10	mA
ST maximum input voltage	V _{ST} max		15	V
Allowable power dissipation	P _d max	Mounted on a specified board *	800	mW
Operating temperature	T _{opr}		-30 to +90	°C
Storage temperature	T _{stg}		-55 to +150	°C

* Specified board: 114.3mm × 76.2mm × 1.6mm, glass epoxy board.

Caution 1) Absolute maximum ratings represent the value which cannot be exceeded for any length of time.

Caution 2) Even when the device is used within the range of absolute maximum ratings, as a result of continuous usage under high temperature, high current, high voltage, or drastic temperature change, the reliability of the IC may be degraded. Please contact us for the further details.

■ Any and all SANYO Semiconductor Co.,Ltd. products described or contained herein are, with regard to "standard application", intended for the use as general electronics equipment. The products mentioned herein shall not be intended for use for any "special application" (medical equipment whose purpose is to sustain life, aerospace instrument, nuclear control device, burning appliances, transportation machine, traffic signal system, safety equipment etc.) that shall require extremely high level of reliability and can directly threaten human lives in case of failure or malfunction of the product or may cause harm to human bodies, nor shall they grant any guarantee thereof. If you should intend to use our products for new introduction or other application different from current conditions on the usage of automotive device, communication device, office equipment, industrial equipment etc. , please consult with us about usage condition (temperature, operation time etc.) prior to the intended use. If there is no consultation or inquiry before the intended use, our customer shall be solely responsible for the use.

■ Specifications of any and all SANYO Semiconductor Co.,Ltd. products described or contained herein stipulate the performance, characteristics, and functions of the described products in the independent state, and are not guarantees of the performance, characteristics, and functions of the described products as mounted in the customer's products or equipment. To verify symptoms and states that cannot be evaluated in an independent device, the customer should always evaluate and test devices mounted in the customer's products or equipment.

SANYO Semiconductor Co., Ltd.

<http://semicon.sanyo.com/en/network>

LB1962MC

Allowable Operating Conditions at Ta = 25°C

Parameter	Symbol	Conditions	Ratings	Unit
Power supply voltage	V _{CC}		3.8 to 16.8	V
ST input High level voltage	ST _H		3 to 14	V
ST input Low level voltage	ST _L		-0.3 to +0.4	V
Hall input common mode voltage	V _{ICM}		0.2 to V _{CC} -1.5	V

Electrical Characteristics at Ta = 25°C, V_{CC} = 5V

Parameter	Symbol	Conditions	Ratings			Unit
			min	typ	max	
Current drain	I _{CC}	In drive mode (CT = "L", ST = "L")		6.5	9.1	mA
		In lockup protection mode (CT = "H", ST = "L")		2.2	3.1	mA
		In standby mode (ST = "H")		110	150	μA
Lockup detection capacitor charge current	I _{CT1}		1.9	2.8	3.7	μA
Capacitor discharge current	I _{CT2}		0.32	0.46	0.60	μA
Capacitor charge/discharge current ratio	R _{CT}	R _{CT} = I _{CT1} /I _{CT2}	5.0	6.0	7.0	
CT charge voltage	V _{CT1}		2.55	2.75	2.95	V
CT discharge voltage	V _{CT2}		1.6	1.8	2.0	V
Output Low level voltage	V _{OL}	I _O = 200mA		0.2	0.3	V
Output High level voltage	V _{OH}	I _O = 200mA	3.9	4.1		V
Hall input sensitivity	V _{HN}	Zero peak value (Including offset and hysteresis)		7	15	mV
FG output pin Low voltage	V _{FG}	I _{FG} = 5mA		0.1	0.3	V
FG output pin leakage current	I _{FGL}	V _{FG} = 15V			30	μA
HB output Low voltage	V _{HBL}	I _{HB} = 5mA		1.0	1.3	V
ST pin input current	I _{ST}	V _{ST} = 5V		75	100	μA

Package Dimensions

unit : mm (typ)

3426A

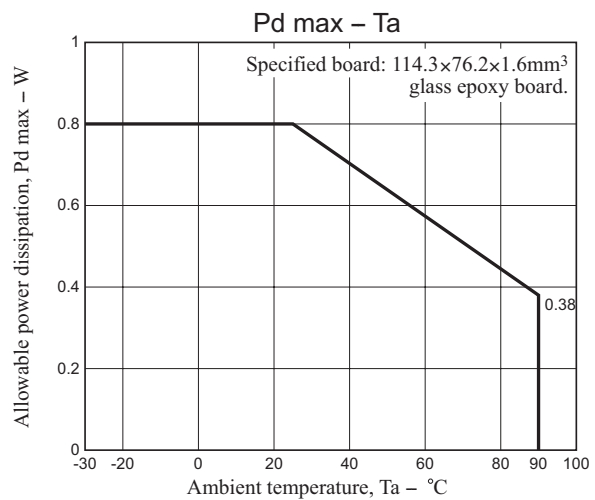
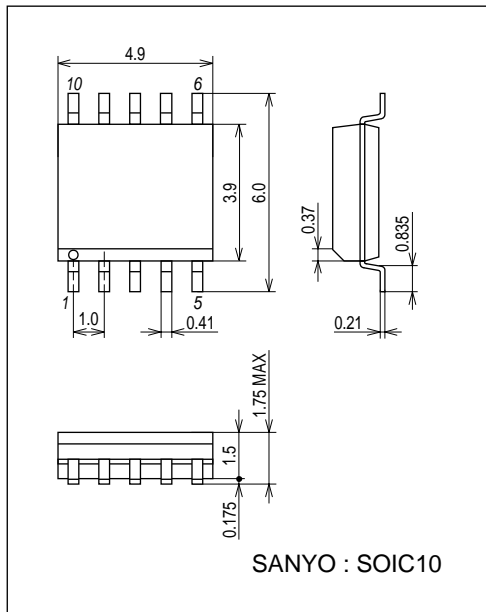

LB1962MC

Pin Assignment

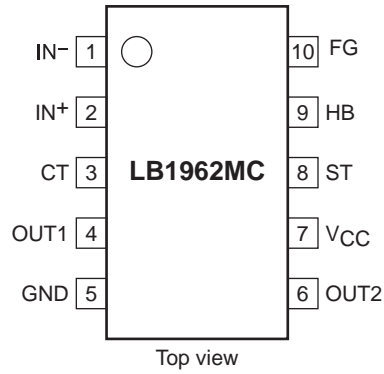

Block Diagram

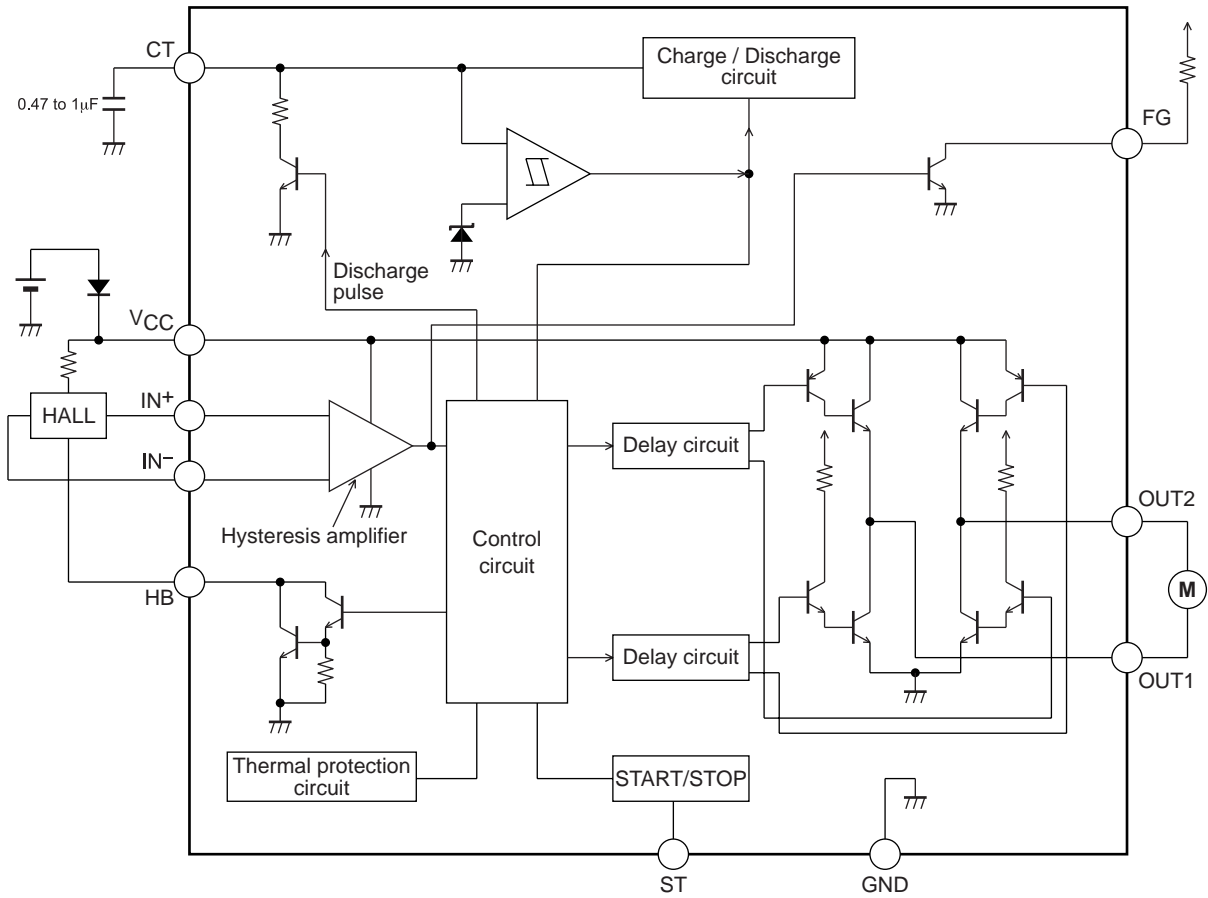

Truth Table

ST	IN-	IN+	CT	OUT1	OUT2	FG	HB	Mode
H	-	-	-	OFF	OFF	OFF	OFF	Standby
L	H	L	L	H	L	L	L	Rotating
	L	H		L	H	H		
-	-	-	H	OFF	OFF	-	L	Lockup protection activated

Latch-type RD output is Low during rotation and High during stop.

Startup

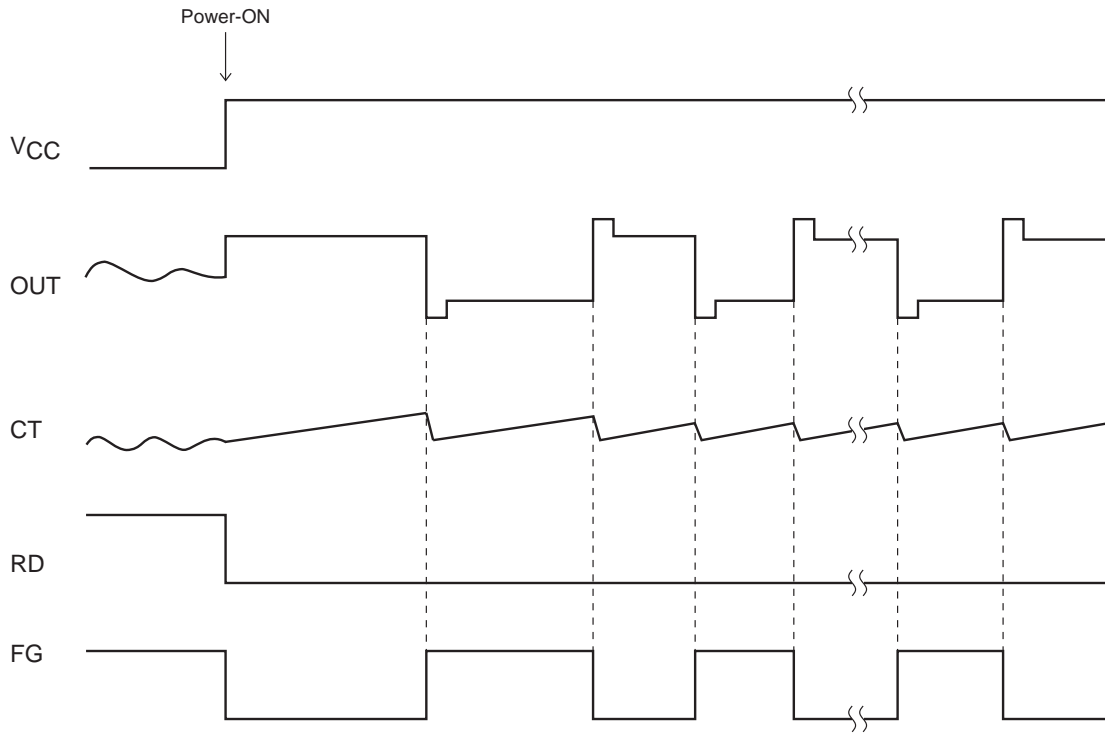

Lockup protection/automatic recovery

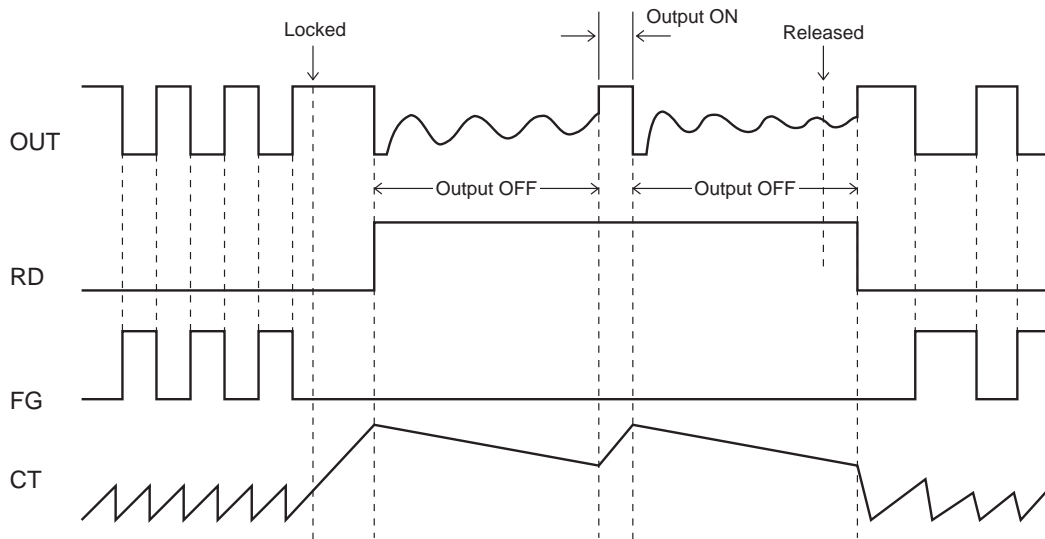

Start/stop

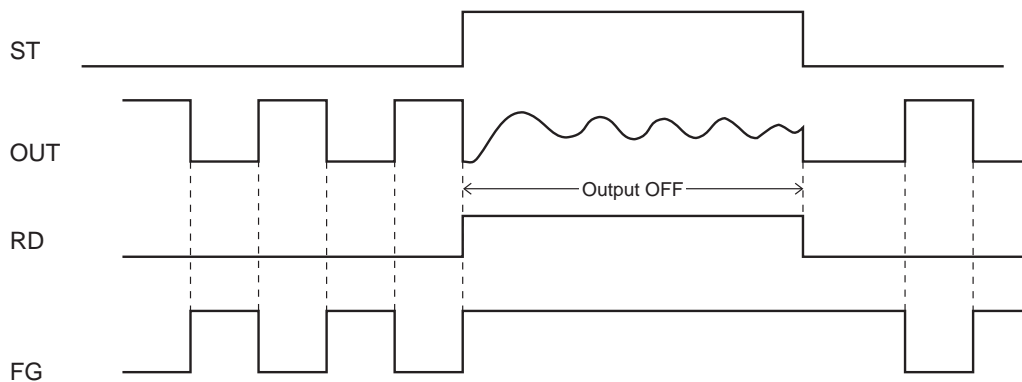

Design Reference**(1) V_{CC} pin**

Power supply pin for control block and motor drive.

Accepts a wide operation voltage range from 3.8 to 16.8V, for 5V/12V dual power supply support.

(2) OUT1, OUT2 pins

Single-phase coil output pins.

Bipolar drive output with upper side inverted and lower side single output. Built-in regenerative circuit regenerates kickback current between lower side NPN outputs when a diode is used for protection against reverse connection.

(3) IN⁻, IN⁺ pins

Hall input signal pins

The Hall signal is amplified into a square wave by the Hall amplifier with hysteresis characteristics of $\pm 3.5\text{mV}$ (typ.).

The Hall input signal amplitude should be 70mV or more.

(4) CT pin

This pin serves for connecting a capacitor between CT and GND.

The capacitor determines the characteristics of the built-in lockup protection circuit for preventing coil burnout in the case of motor restraint. Once normal motor load is restored, the automatic recovery circuit resets itself.

Changing the capacitance alters the lockup detection time.

When a 0.47 mF capacitor is connected between CT and GND

Lockup detection time : approx. 0.5s

Lockup protection time/automatic recovery time : approx. 0.16s (output ON)

approx. 1s (output OFF)

When not using lockup protection function, this pin should be connected to ground.

(5) FG pin

Open-collector output pin for rotation frequency detection.

When IN⁻ = High and IN⁺ = Low, then FG = Low

When IN⁻ = Low and IN⁺ = High, then FG = High

(6) ST pin and HB pin

ST pin : When input to this pin is High, motor drive is stopped (OUT is high impedance).

At this time, RD output indicates lockup protection mode OFF.

HB pin : Hall bias switching pin. At ST pin High input, Hall bias is switched to reduce current drain in fan standby mode.

If not used, both pins should be open.

(7) Thermal protection circuit

When internal temperature T_j of IC reaches 180°C, output current limiter is activated to protect against damage.

LB1962MC

Application Circuit Example

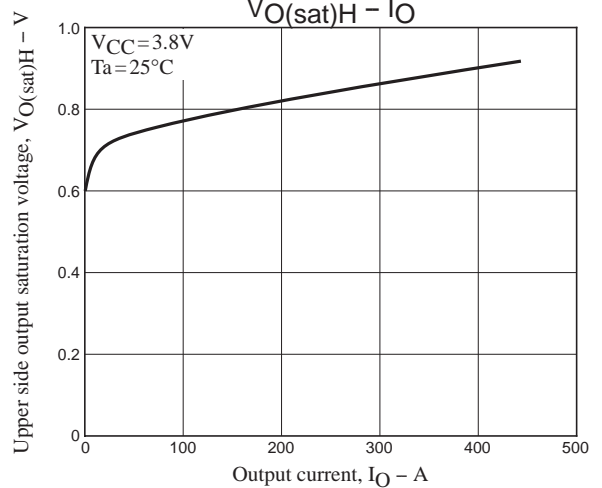
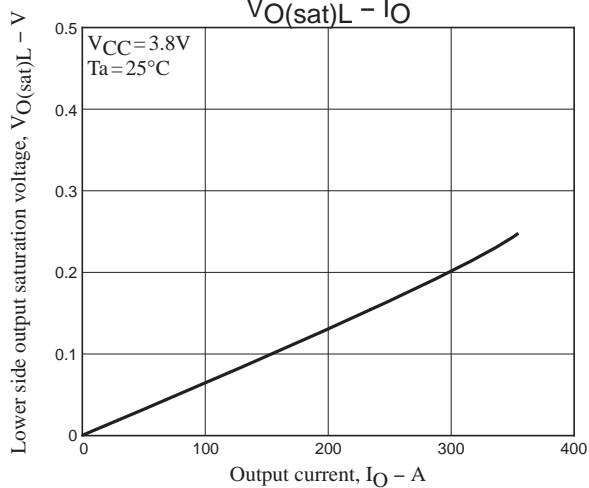
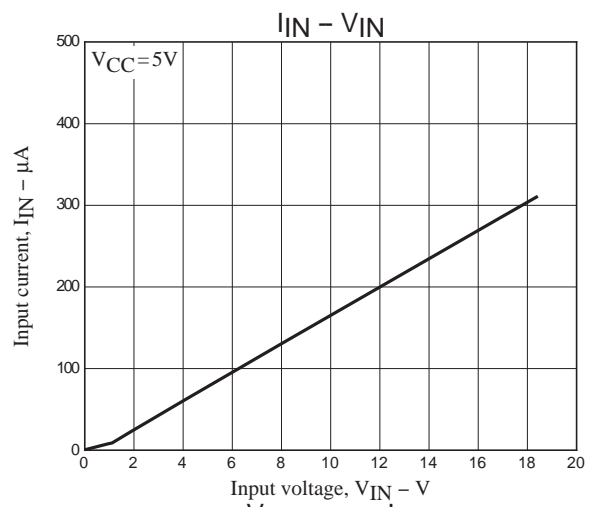
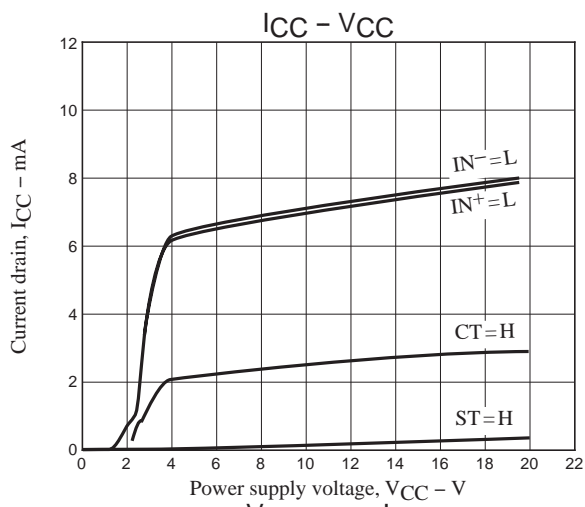
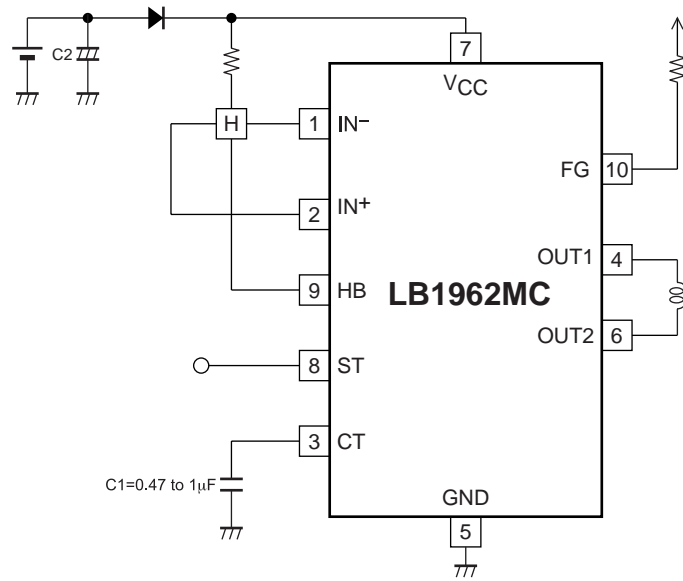

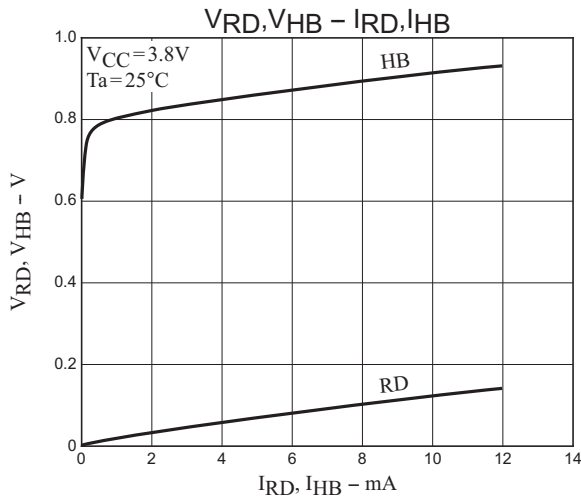

- SANYO Semiconductor Co.,Ltd. assumes no responsibility for equipment failures that result from using products at values that exceed, even momentarily, rated values (such as maximum ratings, operating condition ranges, or other parameters) listed in products specifications of any and all SANYO Semiconductor Co.,Ltd. products described or contained herein.
- Regarding monolithic semiconductors, if you should intend to use this IC continuously under high temperature, high current, high voltage, or drastic temperature change, even if it is used within the range of absolute maximum ratings or operating conditions, there is a possibility of decrease reliability. Please contact us for a confirmation.
- SANYO Semiconductor Co.,Ltd. strives to supply high-quality high-reliability products, however, any and all semiconductor products fail or malfunction with some probability. It is possible that these probabilistic failures or malfunction could give rise to accidents or events that could endanger human lives, trouble that could give rise to smoke or fire, or accidents that could cause damage to other property. When designing equipment, adopt safety measures so that these kinds of accidents or events cannot occur. Such measures include but are not limited to protective circuits and error prevention circuits for safe design, redundant design, and structural design.
- In the event that any or all SANYO Semiconductor Co.,Ltd. products described or contained herein are controlled under any of applicable local export control laws and regulations, such products may require the export license from the authorities concerned in accordance with the above law.
- No part of this publication may be reproduced or transmitted in any form or by any means, electronic or mechanical, including photocopying and recording, or any information storage or retrieval system, or otherwise, without the prior written consent of SANYO Semiconductor Co.,Ltd.
- Any and all information described or contained herein are subject to change without notice due to product/technology improvement, etc. When designing equipment, refer to the "Delivery Specification" for the SANYO Semiconductor Co.,Ltd. product that you intend to use.
- Upon using the technical information or products described herein, neither warranty nor license shall be granted with regard to intellectual property rights or any other rights of SANYO Semiconductor Co.,Ltd. or any third party. SANYO Semiconductor Co.,Ltd. shall not be liable for any claim or suits with regard to a third party's intellectual property rights which has resulted from the use of the technical information and products mentioned above.

This catalog provides information as of July, 2012. Specifications and information herein are subject to change without notice.

Компания «Life Electronics» занимается поставками электронных компонентов импортного и отечественного производства от производителей и со складов крупных дистрибьюторов Европы, Америки и Азии.

С конца 2013 года компания активно расширяет линейку поставок компонентов по направлению коаксиальный кабель, кварцевые генераторы и конденсаторы (керамические, пленочные, электролитические), за счёт заключения дистрибьюторских договоров

Мы предлагаем:

- Конкурентоспособные цены и скидки постоянным клиентам.
- Специальные условия для постоянных клиентов.
- Подбор аналогов.
- Поставку компонентов в любых объемах, удовлетворяющих вашим потребностям.
- Приемлемые сроки поставки, возможна ускоренная поставка.
- Доставку товара в любую точку России и стран СНГ.
- Комплексную поставку.
- Работу по проектам и поставку образцов.
- Формирование склада под заказчика.
- Сертификаты соответствия на поставляемую продукцию (по желанию клиента).
- Тестирование поставляемой продукции.
- Поставку компонентов, требующих военную и космическую приемку.
- Входной контроль качества.
- Наличие сертификата ISO.

В составе нашей компании организован Конструкторский отдел, призванный помогать разработчикам, и инженерам.

Конструкторский отдел помогает осуществить:

- Регистрацию проекта у производителя компонентов.
- Техническую поддержку проекта.
- Защиту от снятия компонента с производства.
- Оценку стоимости проекта по компонентам.
- Изготовление тестовой платы монтаж и пусконаладочные работы.



Тел: +7 (812) 336 43 04 (многоканальный)

Email: org@lifeelectronics.ru