

MACX MCR-EX-SL-2NAM-T(-SP)



NAMUR signal conditioner, Ex-i, 2-channel, with transistor output

Data sheet
103753_en_00

© PHOENIX CONTACT 2014-08-19

1 Description

The 2-channel NAMUR signal conditioner **MACX MCR-EX-SL-2NAM-T(-SP)** has been designed for intrinsically safe operation of proximity sensors (as per EN 60947-5-6 (NAMUR)) as well as switch contacts, with open circuit and resistance circuits, installed in hazardous areas.

The input circuits are monitored for line faults such as wire breaks and short circuits. Line fault detection (LFD) can be activated and deactivated. Errors are indicated by a red flashing LED (as per NAMUR NE 44) and the corresponding transistor output is blocked. Error messages can also be transmitted to the supply and error evaluation module via the DIN rail connector.

The output circuits feature one passive transistor for each channel for the transmission of the switching signal to the control level. The switches make it possible to set the direction separately for every channel (open or closed circuit current behavior). The status of the respective channel is signaled via a yellow LED.

Certified for safety-related applications up to SIL 2 according to IEC/EN 61508.

1.1 Properties

- Two-channel
- Intrinsically safe input for NAMUR proximity switches or contacts, [Ex ia]
- Transistor output, (passive), up to 5 kHz
- Line fault detection (LFD)
- Option of phase reversal
- Safe 3-way electrical isolation
- SIL 2 acc. to IEC/EN 61508
- Installation in zone 2 permitted
- Power supply and error indication possible via DIN rail connector
- Plug-in terminals with screw connection (MACX MCR-EX-SL-2NAM-T) or spring connection (push-in) (MACX MCR-EX-SL-2NAM-T-SP)
- Housing overall width 12.5 mm



WARNING: Explosion hazard

The module is an item of associated electrical equipment for intrinsically safe circuits. It is designed for use in zone 2, if specific conditions are observed.

When installing and operating the device, the applicable safety directives (including national safety directives), accident prevention regulations, as well as general technical regulations must be observed.



WARNING: Explosion hazard

Observe the safety regulations and installation notes on page 6.



Make sure you always use the latest documentation. It can be downloaded at phoenixcontact.net/products.



This data sheet is valid for all products listed on page 3.

Table of contents

1	Description.....	1
1.1	Properties.....	1
2	Ordering data.....	3
3	Technical Data.....	3
4	Safety regulations and installation notes.....	6
4.1	Installation notes	6
4.2	Intrinsic safety	6
4.3	Installation in the hazardous area (zone 2)	6
4.4	Areas with a danger of dust explosions	6
4.5	Safety-related applications (SIL)	6
5	Installation	7
5.1	Connection notes	7
5.2	Electrostatic discharge	7
5.3	Design	7
5.4	Basic circuit diagram	8
5.5	Inputs (intrinsically safe)	8
5.6	Outputs.....	8
5.7	Supply voltage.....	8
5.8	Dimensions	9
5.9	Assembly.....	9
5.10	Connecting the cables.....	10
5.11	Group error message	10
5.12	Startup.....	10
6	Configuration	11
6.1	Line fault detection (switch DIP2/DIP4)	11
6.2	Phase reversal (switch DIP1/DIP3).....	11
6.3	Truth table	12
7	Comparison of safety data	13
8	Safety-related applications (SIL 2)	14
8.1	Circuits	14
8.2	Diagnostics function via the switches DIP2/DIP4.....	14
8.3	Safe state	14
8.4	Response Times	14
8.5	Operating mode of the safety function.....	14
8.6	Failure behavior and required response	14
8.7	Safety integrity requirements	15
8.8	Conditions	15
8.9	Installation and Startup.....	16
8.10	Notes on operation	16
8.11	Startup and restart.....	16
8.12	Recurring checks	16
8.13	Repair.....	17
8.14	Standards (SIL 2)	17
8.15	Abbreviations	18

2 Ordering data

NAMUR signal conditioner

Description	Type	Order no.	Pcs. / Pkt.
NAMUR signal conditioner, Ex-i, 2-channel, with screw connection	MACX MCR-EX-SL-2NAM-T	2865489	1
NAMUR signal conditioner, Ex-i, 2-channel, with spring connection	MACX MCR-EX-SL-2NAM-T-SP	2924090	1

Accessories

Description	Type	Order no.	Pcs. / Pkt.	
DIN rail connector (T-BUS), 5-pos., for bridging the supply voltage, can be snapped onto NS 35 DIN rail in acc. with EN 60715	ME 6.2 TBUS-2 1.5/5-ST-3.81 GN	2869728	10	
Power and error evaluation module, including the corresponding DIN rail connector ME 17.5 TBUS 1.5/5-ST-3.81 GN	Screw connection	MACX MCR-PTB	2865625	1
	Spring connection	MACX MCR-PTB-SP	2924184	1



For additional accessories, please refer to the catalog from Phoenix Contact.

3 Technical Data

Input

Input	Intrinsically safe, designed for protection type Ex-i [Ex ia] IIC/IIIC ⚠ CAT II (250 V against ⚡)
Available input sources	<ul style="list-style-type: none"> – NAMUR proximity switches according to EN 60947-5-6 or – Switch contacts with open circuit (not for safety-related applications, SIL 2) or – Switch contacts with resistance circuit
Switching hysteresis	Approx. 0.2 mA
Off-load voltage	8 V DC ±10%
Switching points in acc. with IEC/EN 60947-5-6	<ul style="list-style-type: none"> I < 1.2 mA (blocking) I > 2.1 mA (conductive)
Line fault detection	Break 0.05 mA < I _N < 0.35 mA Short circuit 100 Ω < R _{Sensor} < 360 Ω Activated/Deactivated by DIP switches

Switching output

Switching output	1 Transistor, passive (per channel) ⚠ CAT II (250 V against ⚡)
Maximum switching voltage	30 V DC
Minimum switching voltage	3 V DC
Maximum switching current	50 mA, short-circuit-proof
Minimum switching current	5 mA, short-circuit-proof
Drop (ΔU)	< 1.4 V
Switching behavior	Can be inverted by DIP switches
Switching frequency	≤ 5 kHz

General data

Supply voltage range	19.2 V DC ... 30 V DC (24 V DC -20% ... +25%)
Current consumption	< 34 mA (24 V DC)
Power dissipation	≤ 1 W
Status indicator	Green LED (PWR, supply voltage) Red LED (LE, line fault) Yellow LED (OUT, switching state)
Housing material	Polyamide PA 66-FR

General data (continued)	
Color	Green
Degree of protection	IP20
Width x height x depth	12.5 mm x 112.5 mm 114.5 x mm (MACX MCR-EX-SL-2NAM-T) 12.5 mm x 116 mm 114.5 x mm (MACX MCR-EX-SL-2NAM-T-SP)
Inflammability class according to UL 94	0 V
Design	Terminal housing for mounting on DIN rails

Electrical isolation	
Input/Output	375 V _{peak} (peak value acc. to EN 60079-11)
Input/Power supply, DIN rail connector	375 V _{peak} (peak value acc. to EN 60079-11)
Input/Output/Power supply, DIN rail connector	300 V _{eff} rated insulation voltage (Surge voltage category II, pollution degree 2, safe electrical isolation as per EN 61010-1)
	Test voltage 2.5 kV AC (50 Hz, 1 min)
Output 1 / Output 2	50 V _{eff} rated insulation voltage (surge voltage category II, pollution degree 2, basic insulation acc. to EN 61010-1)
	Test voltage 1.0 kV AC (50 Hz, 1 min)

Ambient conditions	
Ambient temperature	
Operation	-20 °C ... +60 °C (any mounting position)
Storage/Transport	-40 °C ... +80 °C
Permissible humidity (operation)	10% ... 95% (non-condensing)
Maximum altitude	2000 m above sea level

Connection data	MACX MCR-EX-SL-2NAM-T	MACX MCR-EX-SL-2NAM-T-SP
Connection method	Screw connection	Push-in spring connection
Conductor cross-section		
solid	0.2 mm ² ... 2.5 mm ²	0.2 mm ² ... 1.5 mm ²
flexible	0.2 mm ² ... 2.5 mm ²	0.2 mm ² ... 1.5 mm ²
AWG/kcmil	24 ... 14	24 ... 16
Stripping length	7 mm	8 mm
Tightening torque	0.5 Nm ... 0.6 Nm	–

Conformance	
EMC Directive 2004/108/EC	EN 61000-6-2, EN 61000-6-4, EN 61326-1
Ex Directive (ATEX)	EN 60079-0, EN 60079-11, EN 60079-15

Safety data according to ATEX for intrinsically safe circuits																									
Voltage, maximum V ₀	9.6 V																								
Maximum current I ₀	10.3 mA																								
Maximum power P ₀	25 mW																								
Maximum inner inductance L _i	negligible																								
Maximum inner capacity C _i	11 nF																								
Gas group																									
Maximum external inductance L ₀	<table border="1"> <thead> <tr> <th colspan="4">IIC</th> <th colspan="4">IIB</th> </tr> <tr> <th>100 mH</th> <th>5 mH</th> <th>1 mH</th> <th>10 μH</th> <th>100 mH</th> <th>5 mH</th> <th>1 mH</th> <th>10 μH</th> </tr> </thead> <tbody> <tr> <td>510 nF</td> <td>840 nF</td> <td>1.2 μF</td> <td>3.6 μF</td> <td>2.7 μF</td> <td>4.4 μF</td> <td>6.3 μF</td> <td>26 μF</td> </tr> </tbody> </table>	IIC				IIB				100 mH	5 mH	1 mH	10 μH	100 mH	5 mH	1 mH	10 μH	510 nF	840 nF	1.2 μF	3.6 μF	2.7 μF	4.4 μF	6.3 μF	26 μF
IIC				IIB																					
100 mH	5 mH	1 mH	10 μH	100 mH	5 mH	1 mH	10 μH																		
510 nF	840 nF	1.2 μF	3.6 μF	2.7 μF	4.4 μF	6.3 μF	26 μF																		
Maximum external capacitance C ₀																									
Safety-related maximum voltage V _m	253 V AC (125 V DC)																								

Approvals

ATEX	IBExU 08 ATEX 1100	Ⓢ II (1) G [Ex ia Ga] IIC Ⓢ II (1) D [Ex ia Da] IIIC Ⓢ II 3 G Ex nA IIC T4 Gc X
IECEX approval	IECEX IBE 08.0005X	[Ex ia Ga] IIC [Ex ia Da] IIIC Ex nA IIC T4 Gc
UL, USA/Canada		Ⓢ, C.D.-No 83104549; IS for Class I,II,III, Division 1 and Zone 0; Installation in Class I, Division 2 and Zone 2
Functional safety (SIL)		SIL 2 according to IEC/EN 61508

4 Safety regulations and installation notes

4.1 Installation notes

- The device is an item of associated equipment (category 1) with “intrinsic safety” protection type and can be installed in zone 2 potentially explosive areas as a category 3 device.

It meets the requirements of

EN 60079-0:2012, IEC 60079-0 Ed. 6.0,
EN 60079-11:2012, IEC 60079-11 Ed. 6.0
EN 60079-15:2010, IEC 60079-15 Ed. 4.0

Installation, operation, and maintenance may only be carried out by qualified electricians.

Follow the installation instructions as described.

When installing and operating the device, the applicable regulations and safety directives (including national safety directives), as well as general technical regulations, must be observed.

For the safety data, refer to this document and the certificates (EC examination certificate and other approvals if appropriate).

- Do not open or modify the device. Do not repair the device yourself; replace it with an equivalent device instead. Repairs may only be carried out by the manufacturer.
- The IP20 degree of protection (EN/IEC 60529) of the device is intended for use in a clean and dry environment. Do not subject the device to mechanical or thermal loads that exceed the specified limits.
- The device complies with the EMC regulations for industrial areas (EMC class A). When using the device in residential areas, it may cause radio interference.

4.2 Intrinsic safety

- The device is approved for intrinsically safe (protection type Ex i) circuits up to zone 0 (gas) and zone 20 (dust) in the hazardous area.

Observe the safety values for intrinsically safe equipment and the connecting cables during connection (IEC/EN 60079-14). They must conform to the values specified in the installation manual, in this data sheet, or the EC-type examination certificate.

- When carrying out measurements on the intrinsically safe side, observe the relevant regulations regarding the connection of intrinsically safe equipment. In intrinsically safe circuits, only use those measuring devices that are approved for these circuits.
- If the device has been used in non-intrinsically safe circuits, it must not be used again in intrinsically safe circuits. The device must be clearly marked as non-intrinsically safe.

4.3 Installation in the hazardous area (zone 2)

- Observe the specified conditions for use in potentially explosive areas!
Install the device in a suitable approved housing (with at least IP54 degree of protection) that meets the requirements of EN 60079-15. Observe the requirements of EN 60079-14.
- Always disconnect the power before connecting or disconnecting non-intrinsically safe cables.
- In potentially explosive areas, always disconnect the power before snapping the device on or off the DIN rail connector.
- The device must be stopped and immediately removed from the hazardous area if it is damaged or was subjected to an impermissible load or stored incorrectly or if it malfunctions.

4.4 Areas with a danger of dust explosions

- The device is not designed for installation in zone 22.
- If, however, you wish to use the device in zone 22, it must be installed in a housing that complies with IEC/EN 60079-31. In doing so, observe the maximum surface temperatures. Observe the requirements of IEC/EN 60079-14.
- Connection to the intrinsically safe circuit in areas with a danger of dust explosions (Zone 20, 21 or 22) is only permitted if the equipment connected to this circuit is approved for this zone (e.g. Category 1D, 2D or 3D).

4.5 Safety-related applications (SIL)

When using in safety-related applications, observe the instructions in Section 8, as the requirements differ for safety-related functions.

5 Installation

5.1 Connection notes



WARNING: Electrical danger due to improper installation

Observe the connection notes for safe installation in accordance with EN/UL 61010-1:

- Near the device, provide a switch/circuit breaker that is labeled as the **disconnect device** for this device (or the entire control cabinet).
- Provide **overcurrent safety equipment** ($I \leq 16 \text{ A}$) in the installation.
- To protect the device against mechanical or electrical damage, install it in a suitable **housing** with an appropriate degree of protection according to IEC 60529.
- If **several devices are installed next to each other**, make sure that the device has a housing that features a basic insulation for $300 \text{ V}_{\text{eff}}$. Install additional insulation, if necessary. If the neighboring device is equipped with basic insulation, no additional insulation is required.
- The voltages present at the input, output, and supply are extra-low voltages (**ELV**). Depending on the application, **hazardous voltage** ($> 30 \text{ V AC}$) to ground may occur. For this event, safe electrical isolation from the other connections has been implemented.
- Before performing any **servicing or maintenance work**, ensure that the device is disconnected from all effective power sources.
- Always disconnect the device from the power before switching the **DIP switches**.
- If the device is not used as described in the documentation, the intended protection may be impaired.

5.2 Electrostatic discharge



NOTE: Electrostatic discharge!

The device contains components that can be damaged or destroyed by electrostatic discharge. When handling the device, observe the necessary safety precautions against electrostatic discharge (ESD) according to EN 61340-5-1 and IEC 61340-5-1.

5.3 Design

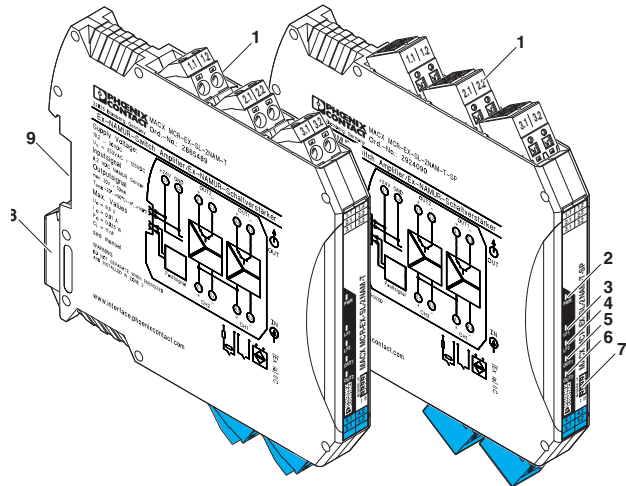

Figure 1 Design MACX MCR-EX-SL-2NAM-T(-SP)

- | | |
|---|---|
| 1 | Plug-in COMBICON screw or push-in connectors with integrated test sockets |
| 2 | LED PWR green Supply voltage |
| 3 | LED LF1 red Line fault, sensor cable 1 |
| 4 | LED LF2 red Line fault, sensor cable 2 |
| 5 | LED OUT1 yellow Switching state, transistor output channel 1 |
| 6 | LED OUT2 yellow Switching state, transistor output channel 2 |
| 7 | Switch DIP1 ... DIP4 |
| 8 | Snap-on foot for fixing to the DIN rail |
| 9 | Connection option for DIN rail connector |

5.4 Basic circuit diagram

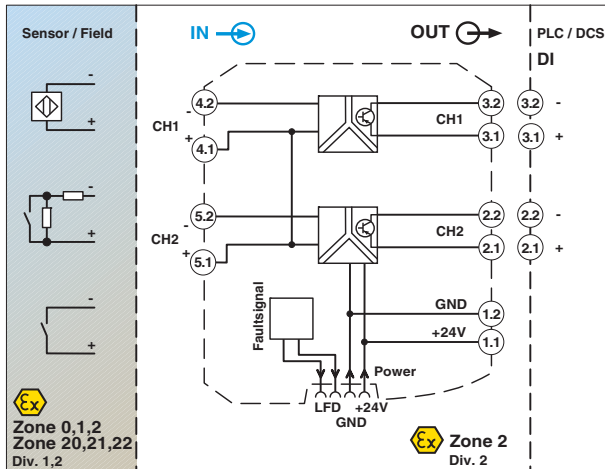

Figure 2 Basic circuit diagram with connection terminals

5.5 Inputs (intrinsically safe)

Connection of NAMUR proximity switches or (resistance) switch contacts

- Channel 1 Terminals 4.1 (+) and 4.2 (-)
- Channel 2 Terminals 5.1 (+) and 5.2 (-)

5.6 Outputs

One passive transistor each

- Channel 1 Terminals 3.1 (+) and 3.2 (-)
- Channel 2 Terminals 2.1 (+) and 2.2 (-)

5.7 Supply voltage

The modules can be supplied with voltage via the connection terminals as well as via the DIN rail connector.

Supply via connection terminals

The supply voltage is fed in through the connection terminals 1.1 (+) and 1.2 (-).

Supply via DIN rail connector

The supply voltage can be fed in via an MACX MCR-EX-SL module or via the power and fault signaling module MACX MCR-PTB(-SP) to the DIN rail connector.



NOTE: Never connect the supply voltage directly to the DIN rail connector. Drawing power from the DIN rail connector is not permitted.

- **Supply via an MACX MCR-EX-SL module**
If the total current consumption of the modules in series does not exceed 400 mA, power can be supplied directly at the connection terminals of the module. Up to 16 modules can be supplied depending on the current consumption of the modules. We recommend connecting a 630 mA fuse (normal-blow or slow-blow) upstream.
- **Supply via the power and fault signaling module MACX MCR-PTB(-SP)**
The supply voltage is supplied via the MACX MCR-PTB(-SP) module to the DIN rail connector. Simple or redundant diode-decoupled power supply is possible. The MACX MCR-PTB(-SP) module is protected by a fuse. Depending on the current consumption of the modules, up to 150 individual modules can be supplied. The module has integrated error evaluation. An auxiliary supply failure or fuse fault is indicated at a relay output and displayed via a flashing LED.

5.8 Dimensions

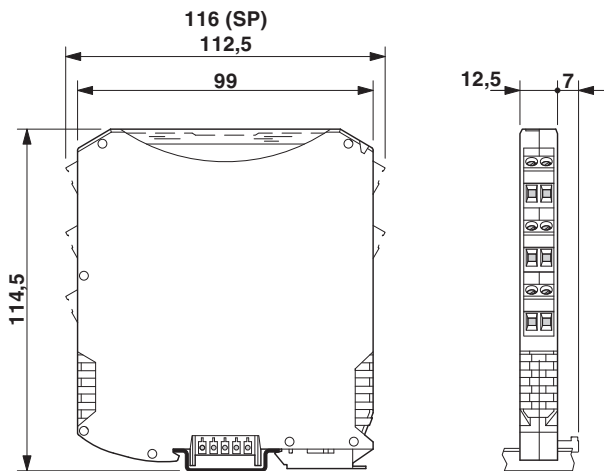

Figure 3 Dimensions (in mm)

5.9 Assembly

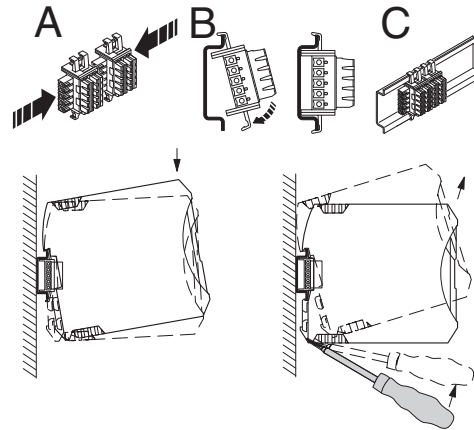

Figure 4 Assembly and Removal

- Mount the module on a 35 mm DIN rail according to EN 60715.
- When using the DIN rail connector, first place it into the DIN rail (see A – C, Figure 4). It is used to bridge the voltage supply and for error messages. Please also observe the direction of the module and DIN rail connector when snapping into position: Snap-on foot below and connector left.
- Install the module in suitable housing to meet the requirements for the protection class.

5.10 Connecting the cables

Screw connection

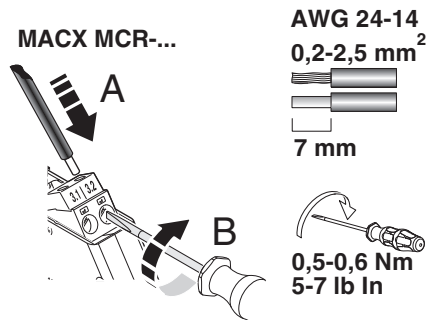

Figure 5 Screw connection

Permissible conductor cross section: 0.2 mm² ... 2.5 mm²

- Strip the wire by approximately 7 mm and crimp ferrules to the end of the wires.
- Insert the conductor into the corresponding connection terminal.
- Use a screwdriver to tighten the screw in the opening above the connection terminal.

Connection torque: 0.6 Nm

Spring connection (push-in connection)

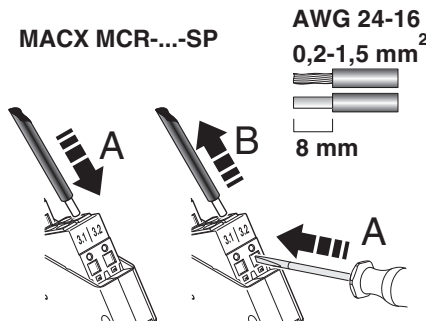

Figure 6 Push-in connection

Permissible conductor cross section: 0.2 mm² ... 1.5 mm²

- Strip the wire by approximately 8 mm and crimp ferrules to the end of the wires.
- Insert the wire into the round opening of the terminal without using a tool.
- Push in the pushbutton with a screwdriver to release.

5.11 Group error message

Line fault messages from NAMUR signal conditioners that are connected via DIN rail connectors are signaled as a group error message from the power and fault signaling module MACX MCR-PTB(-SP) via a relay output and indicated by a flashing LED.

5.12 Startup

- Before startup, check that the NAMUR signal connector Ex is wired correctly, in particular with regard to the wiring and marking of the intrinsically safe circuits.

6 Configuration



NOTE: Always disconnect the device from the power before switching the **DIP switches**.

In the default state upon delivery, all DIP switches are set to the position "I".



Channel 1	Channel 2
DIP1	DIP3 = I Normal phase (operating current behavior)
DIP1	DIP3 = II Inverse phase (closed circuit current behavior)
DIP2	DIP4 = I Line fault detection disabled*
DIP2	DIP4 = II Line fault detection enabled
PWR =	Supply voltage
OUT =	Switching state of the transistor
LF =	Line fault on the sensor cable

* (not permitted for safety-related applications, SIL 2)

6.1 Line fault detection (switch DIP2/DIP4)



WARNING: For safety-related applications, **only** the switch position "**DIP2/DIP4=II**" is **permitted!**

Line fault detection is activated and deactivated by the switches DIP2 (for channel 1) and DIP4 (for channel 2).

If line fault detection is activated, the transistor is disabled if a line fault occurs. The red LED (LF) flashes (NAMUR NE 44).

Operating range according to EN 60947-5-6 for signaling the line fault.

- Line break $0.05 \text{ mA} < I_{IN} < 0.35 \text{ mA}$
- Short circuit $100 \text{ } \Omega < R_{\text{Sensor}} < 360 \text{ } \Omega$

If the module is connected to a power module MACX MCR-PTB(-SP) via a DIN rail connector, a group error message is also sent to the higher-level evaluation unit via floating relay output (see Chapter 5.11).



NOTE: For **switch contacts with open circuit** (Figure 7), line fault detection (DIP2/DIP4 = I) has to be disabled or the corresponding resistance circuit has to be provided directly at the switch contact (Figure 8, e.g. UKK 5-2R/NAMUR (Order No. 2941662) with D-UKK 3/5 (Order No. 2770024)).

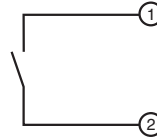

Figure 7 Switch contact with open circuit

(not permitted for safety-related applications, SIL 2)

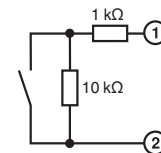

Figure 8 Switch contact with resistance circuit

6.2 Phase reversal (switch DIP1/DIP3)

The phase reversal function is activated and deactivated by the switches DIP1 (for channel 1) and DIP3 (for channel 2).

Channel 1 Channel 2

DIP1	DIP3 = I	Normal phase
DIP1	DIP3 = II	Inverse phase

Transistor	Normal phase (I)	Inverse phase (II)
Conductive if	$I > 2.1 \text{ mA}$	$I < 1.2 \text{ mA}$
Blocking if	$I < 1.2 \text{ mA}$	$I > 2.1 \text{ mA}$

6.3 Truth table



WARNING: For safety-related applications, **only** the switch position "DIP2/DIP4=II" is **permitted!**



WARNING: Apart from NAMUR sensors, **only** switches with resistance circuit are **permitted** at the input for safety-related applications (see Figure 8).

	Sensor in input		Input circuit	DIP switches				Output Transistor	LED OUT yellow	LF LED red	Permitted for safety-related applications
	Switch	NAMUR		State	Channel 1		Channel 2				
			1		2	3	4				
	Open	Blocking	OK	I	I	I	I	Blocking			no
	Closed	Conductive	OK	I	I	I	I	Conductive	X		no
	Open	Blocking	OK	II	I	II	I	Blocking	X		no
	Closed	Conductive	OK	II	I	II	I	Conductive			no
		Blocking	OK	I	II	I	II	Blocking			yes
		Conductive	OK	I	II	I	II	Conductive	X		yes
		Any	Open circuit	I	II	I	II	Blocking		X	yes
		Any	Short circuit	I	II	I	II	Blocking		X	yes
		Blocking	OK	II	II	II	II	Conductive	X		yes
		Conductive	OK	II	II	II	II	Blocking			yes
		Any	Open circuit	II	II	II	II	Blocking		X	yes
		Any	Short circuit	II	II	II	II	Blocking		X	yes

DIP2/DIP4 = I Line fault detection disabled

(not permitted for safety-related applications, SIL 2)

DIP2/DIP4 = II Line fault detection enabled

DIP1/DIP3 = I Normal phase

DIP1/DIP3 = II Inverse phase

LED PWR = Supply voltage

LED OUT = Switching state of the transistor

LED LF = Line fault on the sensor cable

7 Comparison of safety data



WARNING: Explosion hazard

Compare the safety data before connecting a device located in the Ex-i area to the MACX MCR-EX-SL-2NAM-T(-SP).

Provide proof of intrinsic safety according to standard IEC/EN 60079-14 and other national standards and installation specifications, if applicable.

Safety data for the

Field devices: V_i, I_i, P_i, L_i, C_i

Ex i NAMUR signal conditioner: V_o, I_o, P_o, L_o, C_o

The values for V_o, I_o, P_o, L_o , and C_o can be found under "Safety data according to ATEX for intrinsically safe circuits" on page 4.

Example for proof of intrinsic safety (simple circuit)

$$V_i \geq V_o$$

$$I_i \geq I_o$$

$$P_i \geq P_o$$

$$L_i + L_c \leq L_o$$

$$C_i + C_c \leq C_o$$

L_c and C_c depend on the cables/lines used.

8 Safety-related applications (SIL 2)

SIL regulations apply to the following modules:

Designation	Order no.
MACX MCR-EX-SL-2NAM-T	2865489
MACX MCR-EX-SL-2NAM-T-SP	2924090
MACX MCR-SL-2NAM-T	2865036
MACX MCR-SL-2NAM-T-SP	2924281

A hardware assessment (FMEDA report) is available for the aforementioned safety-related NAMUR signal conditioners: Exida_07/06-39_R006_V1R2.

8.1 Circuits

Input

Permitted for safety-related applications:

- NAMUR sensor (according to EN 60947-5-6)
- Switch contact with resistance circuit (1 k Ω serial and 10 k Ω parallel (tolerance $\pm 10\%$))
(Note: The resistance circuit regulates the behavior of a NAMUR sensor)



WARNING: Switch contacts without resistance circuit are **not permitted** for safety-related applications.

Output

The safety-related function at the output is dependent on the position of the switches DIP1 (for channel 1) and DIP3 (for channel 2).

- | | |
|------------------------|--|
| I = Normal operation | In the event of a 0 signal (NAMUR sensor high resistance, therefore lower current in the input circuit), the output (transistor) switches to the "non-conductive" state. |
| II = Inverse operation | In the event of a 1 signal at the input, the output switches to the "non-conductive" state. |

8.2 Diagnostics function via the switches DIP2/DIP4

For safety applications, line fault detection is enabled, i.e., the DIP2/DIP4 switches are in the "II" position.



WARNING: The "DIP2/DIP4 = I" switch position is **not permitted** for safety-related applications.

When line fault detection is enabled, the red LED indicates any faults that occur. If a line fault is detected, the output is disabled ("non-conductive"). This behavior is not dependent on the position of the DIP1 and DIP3 switches.

8.3 Safe state

The "safe state" means that the output is in a non-conductive state, i.e., the transistor is blocking.

8.4 Response Times

Following a state change at the input, the output enters the safe state in ≤ 0.2 ms.

8.5 Operating mode of the safety function

Operating mode according to IEC/EN 61508: "Low demand mode".

8.6 Failure behavior and required response

1. The safe state is entered in the event that a line fault is detected or the supply voltage fails (see Section 8.3).
2. The safe state is reached by removing the connection terminals.

8.7 Safety integrity requirements

Failure rates

- Type A device (according to IEC/EN 61508-2)
- Safety Integrity Level (SIL) 2
- HFT = 0
- MTTR = 24 h
- 1oo1 structure

Non-inverted operation:

λ_{SD}	λ_{SU}	λ_{DD}	λ_{DU}	SFF	DC _S	DC _D
12 FIT	251 FIT	15 FIT	64 FIT	81%	4.5%	18.9%

The MTBF is 269 years.

PFD_{avg} values

T _[PROOF] =	1 year	2 years	5 years
PFD _{avg} =	2.80E-04	5.61E-04	1.40E-03

Inverted operation:

λ_{SD}	λ_{SU}	λ_{DD}	λ_{DU}	SFF	DC _S	DC _D
2 FIT	262 FIT	12 FIT	64 FIT	81%	0%	15.7%

The MTBF is 269 years.

PFD_{avg} values

T _[PROOF] =	1 year	2 years	5 years
PFD _{avg} =	2.80E-04	5.61E-04	1.40E-03

The box marked in white shows that the calculated PFD_{avg} values are within the permissible range for SIL2 in accordance with Table 2 of IEC/EN 61508-1. However, they do not fulfill the requirement to not cover more than 10% of this safety circuit, i.e., to be better than or equal to 1.00 E03.

The boxes marked in gray show that the calculated PFD_{avg} values are within the permissible range for SIL 2 in accordance with Table 2 of IEC/EN 61508-1. They fulfill the requirement to not cover more than 10% of the safety circuit, i.e., to be better than or equal to 1.00E-03.

Failure limit

The operating mode is based on low demand mode. The device covers less than 10% of the PFH/PFD of the entire safety circuit.

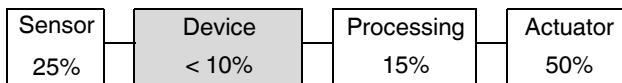

Figure 9 Safety circuit

8.8 Conditions

- The failure rates of the components used remain constant throughout the period of use.
- The propagation of errors by the device in the system is not taken into consideration.
- The repair time (replacement) should be eight hours.
- The failure rates of the external power supply are not taken into consideration.
- Line fault detection is enabled.
- The average temperature at which the device is to be used is +40 °C. In this case, normal industrial conditions are assumed.

The specified error rates are based on an average ambient temperature of +40 °C. For an average ambient temperature of +60 °C, the specified failure rates must be multiplied by a factor of 2.5. This factor is based on guide values.

8.9 Installation and Startup



NOTE: Installation, operation, and maintenance may only be carried out by qualified electricians.

During installation, also follow the installation notes, which pertain to delivery of the device. (PACKB. MACX MCR-EX-SL-2NAM-T(-SP), MNR 9040239). They can also be downloaded at phoenixcontact.net/products.

- Configure the device according to its safety requirements based on the truth table on page 12. Observe the non-approved switch positions for safety-related applications.
- Connect the NAMUR signal conditioner according to the installation manual.
- Check the functionality of the NAMUR signal conditioner with connected sensor or switch contacts with resistance circuit for correct function.
- Start up the safety circuit and check that it operates correctly.

8.10 Notes on operation

During normal operation, the green (PWR) LED is always on. The yellow LEDs (OUT1/OUT2) indicate the switch condition of the output transistor. The red LEDs indicate if there is a line fault when the line fault detection is enabled. The safe state is entered in the event that a line fault is detected or the supply voltage fails.

8.11 Startup and restart

Startup or restart of the device

Behavior: The output enters the state without oscillation (according to the truth table on page 12). A reset is not required.

What happens when a line fault is detected and what must the user do?

Behavior: The fault is indicated by the red LED and the output enters the "non-conductive" state regardless of the input signal and the operating mode (normal or inverse mode). The user has to eliminate the line fault (short circuit or break in the sensor cable).

The device output is not blocked when fault detection is triggered (no lock or reset). Undefined line states that occur during repairs can switch the output. The user must prevent this from happening by disconnecting the supply voltage or removing the connection terminals.

Other options that have the same result and do not present an additional hazard are also permitted.

The line fault is removed.

Behavior: The user has to ensure that a defined state is entered using the truth table on page 12. The device is restarted in the same way as during initial startup. The device then behaves as described under „Startup or restart of the device“.

8.12 Recurring checks

- Check the function of the entire safety circuit according to IEC/EN 61508 and EN 61511. The intervals for checking are specified by the intervals of each individual device within the safety circuit.
It is the operator's responsibility to select the type of checks and the checking intervals in the specified time period.
Checking must be carried out in such a way that the correct function of the safety equipment in conjunction with all components can be verified.

Possible procedure for recurring checks for discovering dangerous and undetected device failures

1. Apply an appropriate signal at the input of the NAMUR signal conditioner in order to obtain the non-conductive state at the output. Check whether the output is non-conductive.
2. Check the conducting status in the same manner.
3. Restore the safety circuit to full functionality.
4. Resume normal operation.

With this test around 99% of the possible "du" ("dangerous undetected") errors in the NAMUR signal conditioner are discovered.

If the function test result is negative, the device must be taken out of operation and the process put into a safe state by other measures.

8.13 Repair

The devices have a long service life, are protected against malfunctions, and are maintenance-free. However, if a device should fail, send it back to Phoenix Contact. The type of malfunction and possible cause has to be stated.

Please use the original packaging or other suitable safe packaging when sending devices back for repairs.

Phoenix Contact GmbH & Co KG
Abteilung Service und Reparatur
Flachmarktstr. 8
32825 Blomberg
GERMANY

8.14 Standards (SIL 2)

The devices are developed and tested according to the following standards:

- | | |
|-------------------|---|
| IEC/EN 61508:2001 | Functional safety of electrical/electronic/programmable electronic safety-related systems |
| EN 61326-1:2006 | Electrical equipment for measurement, control and laboratory use - EMC requirements |

8.15 Abbreviations

Abbreviation		Meaning
DC	Diagnostic Coverage	Diagnostic coverage of safe failures (DC _S) or dangerous failures (DC _D)
FIT	Failure in time	Number of failures that occur in 10 ⁹ hours
HFT	Hardware Fault Tolerance	Hardware fault tolerance: ability of a function unit to continue with the execution of a demanded function despite existing faults or deviations
MTBF	Mean Time Between Failures	Indicates the average time period between one failure and the next. This includes the length of time that the component functions for until the failure and the downtime.
MTTR	Mean Time To Repair	Indicates the average time needed in order to repair a faulty component.
PFD _{avg}	Average Probability of dangerous Failure on Demand	Average probability of failure on demand of a safety function
PFH	Probability of a Dangerous Failure per Hour	Probability of failure per hour for the safety function
SFF	Safe Failure Fraction	Proportion of safe failures: Proportion of failures without the potential to set the safety-related system to a dangerous or impermissible function state
SIL	Safety Integrity Level	IEC/EN 61508 defines four safety integrity levels (SIL 1 to 4). The higher the Safety Integrity Level of the safety-related system, the lower the probability range for the failure of a safety function.
λ	The failure rate λ indicates the number of errors per time unit. DD Dangerous Detected DU Dangerous Undetected SD Safe Detected SU Safe Undetected	

Компания «Life Electronics» занимается поставками электронных компонентов импортного и отечественного производства от производителей и со складов крупных дистрибьюторов Европы, Америки и Азии.

С конца 2013 года компания активно расширяет линейку поставок компонентов по направлению коаксиальный кабель, кварцевые генераторы и конденсаторы (керамические, пленочные, электролитические), за счёт заключения дистрибьюторских договоров

Мы предлагаем:

- Конкурентоспособные цены и скидки постоянным клиентам.
- Специальные условия для постоянных клиентов.
- Подбор аналогов.
- Поставку компонентов в любых объемах, удовлетворяющих вашим потребностям.
- Приемлемые сроки поставки, возможна ускоренная поставка.
- Доставку товара в любую точку России и стран СНГ.
- Комплексную поставку.
- Работу по проектам и поставку образцов.
- Формирование склада под заказчика.
- Сертификаты соответствия на поставляемую продукцию (по желанию клиента).
- Тестирование поставляемой продукции.
- Поставку компонентов, требующих военную и космическую приемку.
- Входной контроль качества.
- Наличие сертификата ISO.

В составе нашей компании организован Конструкторский отдел, призванный помогать разработчикам, и инженерам.

Конструкторский отдел помогает осуществить:

- Регистрацию проекта у производителя компонентов.
- Техническую поддержку проекта.
- Защиту от снятия компонента с производства.
- Оценку стоимости проекта по компонентам.
- Изготовление тестовой платы монтаж и пусконаладочные работы.



Тел: +7 (812) 336 43 04 (многоканальный)
Email: org@lifeelectronics.ru