



DIN Signal female connector - NFF



General information

Design	IEC 60603-2	types: B, 2B, C, 2C, M female
No. of contacts	max. 96	
Contact spacing	2,54 mm	
Test voltage	1000V	
Contact resistance	max. 20mOhm	
Insulation resistance	min. 10 ⁹ Ohm	
Working current	2A at 20°C (see derating diagram)	40A for type M
Temperature range	-55°C ... +125°C	
	-40°C ... +105°C	or press-in connectors (due to limitations of PCB-material)
Termination technology	press-in, solder pins	
Clearance & creepage distance	min. 1,2 mm each	
Insertion and withdrawal force	16-pole max. 15N	20-pole max. 20N
	48-pole max. 45N	64-pole max. 60N
Mating cycles	PL 1 acc. to IEC 60603-2	500 mating cycles
	PL 2 acc. to IEC 60603-2	400 mating cycles
RoHS - compliant	Yes	
Leadfree	Yes	
Hot plugging	No	

Insulator material

Material	PA (thermoplastics, glass fiber reinforcement 25%)
Color	RAL 7035 (light grey)
UL classification	UL 94-V0
Material group acc. IEC 60664-1	II (400 ≤ CTI < 600)
NFF classification	I2, F1

Contact material

Contact material	Copper alloy
Plating termination zone	Sn over Ni for solder, Ni for press-in
Plating contact zone	Au over PdNi over Ni

Derating diagram acc. to IEC 60512-5 (Current carrying capacity)

The current carrying capacity is limited by maximum temperature of materials for inserts and contacts including terminals.

The current capacity curve is valid for continuous, non interrupted current loaded contacts of connectors when simultaneous power on all contacts is given, without exceeding the maximum temperature.

Control and test procedures according to DIN IEC 60512-5

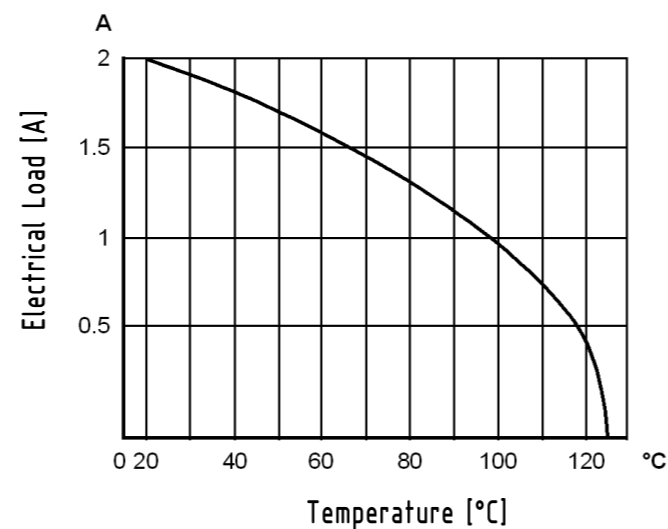

Recommended configuration of plated through holes for press-in termination

In addition to the hot-air-level (HAL), other PCB surfaces are getting more important. Due to their different properties - such as mechanical strength and coefficient of friction - we recommend the following configuration of PCB through holes.

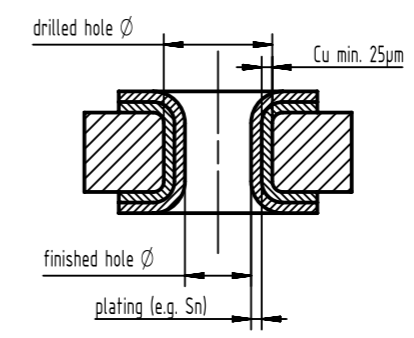

Plating	Drilled hole Ø	Finished hole Ø
Tin plated PCB (HAL) acc. to EN 60352-5	1,15±0,025 mm	max. 15 µm
	0,94 - 1,09 mm	
Chemical tin plated PCB	1,15±0,025 mm	min. 0,8µm
	1,00 - 1,10 mm	
Gold /Nickel plated PCB	1,15±0,025 mm	3 - 7 µm
	0,05 - 0,12 µm	
	1,00 - 1,10 mm	
Silver plated PCB	1,15±0,025 mm	0,1 - 0,3 µm
	1,00 - 1,10 mm	
Copper plated PCB (OSP)	1,15±0,025 mm	
	1,00 - 1,10 mm	

Assembly instructions

It is highly recommended to use HARTING press-in tools to ensure a reliable press-in process. Please refer to the catalogue for tools, machines and further information about the press-in process.

Soldering instructions

The connectors should be protected when being soldered in a dip, flow or film soldering baths. Otherwise, they might become contaminated as a result of soldering operations or deformed as a result of overheating.

(1) For prototypes and short runs protect the connectors with an industrial adhesive tape, e.g. Tesaband 4331 (www.tesa.de). Cover the underside of the connector moulding and the adjacent parts of the pcb as well as the open sides of the connector. This will prevent heat and gases of the soldering apparatus from damaging the connector. About 140 + 5 mm of the tape should suffice.

(2) For large series a jig is recommended. Its protective cover with a fast action mechanical locking device shields the connectors from gas and heat generated by the soldering apparatus. As an additional protection a foil can be used for covering the parts that should not be soldered.

Cross section of solder terminations

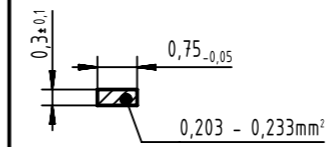

	All rights reserved	Created by HAGEMEYERE	Inspected by TADJE	Standardisation HOFFMANN	Date 2014-09-10	State Final Release
	Department EC PD - DE	Title DIN Signale female connector - NFF		Doc-Key / ECM-Nr. 100580364/UGD/000/A 50000076066		
HARTING Electronics GmbH D-32339 Espelkamp		Type DS	Number 09032120001		Rev. A	Page 1/1

Mouser Electronics

Authorized Distributor

Click to View Pricing, Inventory, Delivery & Lifecycle Information:

[HARTING:](#)

[09032962824222](#)

Компания «Life Electronics» занимается поставками электронных компонентов импортного и отечественного производства от производителей и со складов крупных дистрибьюторов Европы, Америки и Азии.

С конца 2013 года компания активно расширяет линейку поставок компонентов по направлению коаксиальный кабель, кварцевые генераторы и конденсаторы (керамические, пленочные, электролитические), за счёт заключения дистрибьюторских договоров

Мы предлагаем:

- Конкурентоспособные цены и скидки постоянным клиентам.
- Специальные условия для постоянных клиентов.
- Подбор аналогов.
- Поставку компонентов в любых объемах, удовлетворяющих вашим потребностям.
- Приемлемые сроки поставки, возможна ускоренная поставка.
- Доставку товара в любую точку России и стран СНГ.
- Комплексную поставку.
- Работу по проектам и поставку образцов.
- Формирование склада под заказчика.
- Сертификаты соответствия на поставляемую продукцию (по желанию клиента).
- Тестирование поставляемой продукции.
- Поставку компонентов, требующих военную и космическую приемку.
- Входной контроль качества.
- Наличие сертификата ISO.

В составе нашей компании организован Конструкторский отдел, призванный помогать разработчикам, и инженерам.

Конструкторский отдел помогает осуществить:

- Регистрацию проекта у производителя компонентов.
- Техническую поддержку проекта.
- Защиту от снятия компонента с производства.
- Оценку стоимости проекта по компонентам.
- Изготовление тестовой платы монтаж и пусконаладочные работы.



Тел: +7 (812) 336 43 04 (многоканальный)

Email: org@lifeelectronics.ru