



ON Semiconductor®

<http://onsemi.com>

# LV0221CS

CMOS IC

## Front Monitor OE-IC for Optical Pickups

### Overview

The LV0221CS is a front monitor optoelectronic IC for optical pickups that has a built-in photo diode compatible with three waveforms. LV0221CS is small size and type CSP packages.

### Functions

- PIN photodiode compatible with three wavelengths incorporated.
- Gain adjustment (-6dB to +6dB in 256 steps) through serial communication.
- Amplifier to amplify differential output.

### Specifications

#### Maximum Ratings at $T_a = 25^\circ\text{C}$

Parameter	Symbol	Conditions	Ratings	Unit
Maximum supply voltage	$V_{CC}$		6	V
Allowable power dissipation	Pd1	Glass epoxy one-side substrate 55mm × 45mm × 0.8mm Copper foil area (about 80%), $T_a=75^\circ\text{C}$	136	mW
	Pd2	Glass epoxy one-side substrate 55mm × 45mm × 0.8mm Copper foil area (head: about 85% Tail: about 90%), $T_a=75^\circ\text{C}$	100	mW
Operating temperature	$T_{opr}$		-20 to +85	$^\circ\text{C}$
Storage temperature	$T_{stg}$		-40 to +100	$^\circ\text{C}$

Stresses exceeding Maximum Ratings may damage the device. Maximum Ratings are stress ratings only. Functional operation above the Recommended Operating Conditions is not implied. Extended exposure to stresses above the Recommended Operating Conditions may affect device reliability.

#### Recommended Operating Conditions at $T_a = 25^\circ\text{C}$

Parameter	Symbol	Conditions	Ratings			Unit
			min	typ	max	
Operating supply voltage	$V_{CC}$		4.5	5	5.5	V
Output load capacitance	$C_O$		12	20	33	pF
Output load resistance	$Z_O$		3			k $\Omega$

# LV0221CS

**Electrical Characteristics** at Ta = 25°C, VCC = 5V, RL=6kΩ, CL=20pF

Parameter	Symbol	Conditions	Ratings			Unit
			min	typ	max	
Current dissipation	ICC			18	23.4	mA
Sleep current	Islp				1	mA
Output voltage when shielded	VC	At shielding	1.8	2.0	2.2	V
Output offset voltage	Vofs	At shielding, voltage between VOP-VON	-30	0	30	mV
Temperature dependence of offset voltage *1	Vofs	Ta=-10 to +85°C	-60	0	60	μV/°C
Optical output voltage *1 Voltage between VOP-VON	VLC	Low Gain, λ=780nm, G=0dB	0.21	0.262	0.31	mV/μW
	VLD	Low Gain, λ=650nm, G=0dB	0.22	0.275	0.33	mV/μW
	VLB	Low Gain, λ=405nm, G=0dB	0.14	0.172	0.21	mV/μW
	VMC	Middle Gain, λ=780nm, G=0dB	0.66	0.83	0.99	mV/μW
	VMD	Middle Gain, λ=650nm, G=0dB	0.70	0.87	1.05	mV/μW
	VMB	Middle Gain, λ=405nm, G=0dB	0.43	0.54	0.65	mV/μW
	VHC	High Gain, λ=780nm, G=0dB	1.97	2.46	2.95	mV/μW
	VHD	High Gain, λ=650nm, G=0dB	2.07	2.58	3.10	mV/μW
	VHB	High Gain, λ=405nm, G=0dB	1.29	1.62	1.94	mV/μW
Light output voltage adjustment range *1	G	G=0dB reference, absolute value of adjustment width	5.5	6.0	6.5	dB
D range *1	VoD	Voltage between VOP-VON	1700	2200		mV
Frequency characteristics *1, *2	FcC	-3dB(1MHz reference), λ=780nm Light input = 40μW(DC) + 20μW(AC)	50	75		MHz
	FcD	-3dB(1MHz reference), λ=650nm Light input = 40μW(DC) + 20μW(AC)	60	85		MHz
	FcB	-3dB(1MHz reference), λ=405nm Light input = 40μW(DC) + 20μW(AC)	60	85		MHz
Settling time *1	Tset			15		ns
Response time *1	Tr, Tf	Vo=0.9Vp-p, output level 10 to 90% fc=10MHz, duty=50%			10	ns
Overshoot *1	Ovst	Vo=0.9Vp-p			15	%
Undershoot *1	Unst	Vo=0.9Vp-p			15	%
Linearity *1	Lin	At output voltage 0.5V and 1.0V (Between VOP-VON)	-1	0	1	%
Light-output voltage temperature dependence Voltage between VOP-VON *1, *3	TC	λ=780nm, 25°C reference	10	13	16	%
	TD	λ=650nm, 25°C reference	0	3	6	%
	TB	λ=405nm, 25°C reference	0	3	6	%
Light-output voltage spectral sensitivity Voltage between VOP-VON *1	Vf	λ=785nm ±10nm	-0.8		0.1	%/nm
		λ=660nm ±10nm	-0.4		0.4	%/nm
		λ=405nm ±10nm	0		1.2	%/nm
Step-step voltage ratio *1	DG	(Vn-Vn-1) / Vn *100 *4 Deviation from the ideal curve of above equation	-3	0	3	%

Item with \*1 mark indicate the design reference value.

Item with \*2 mark indicate the frequency characteristics when VOP and VON are applied individually.

The frequency characteristics are for the case of High / Middle / Low gain and for the case when the output voltage adjustment range is -6 to +6dB

Item with \*3 mark indicates the temperature dependence for the case of High / Middle / Low gain and for the case when the temperature is 25 to 85°C for the output voltage adjustment range of -6 to +6dB

Vn in Item with \*4 mark is  $Vn = (\text{sensitivity} / 2) \times 5400 / (5400 - 16 \times \text{GCAstep}) \times \text{light intensity} (\mu\text{W})$

GCA = Gain Control Amplifier

## Package Dimensions

unit : mm (typ)

3402

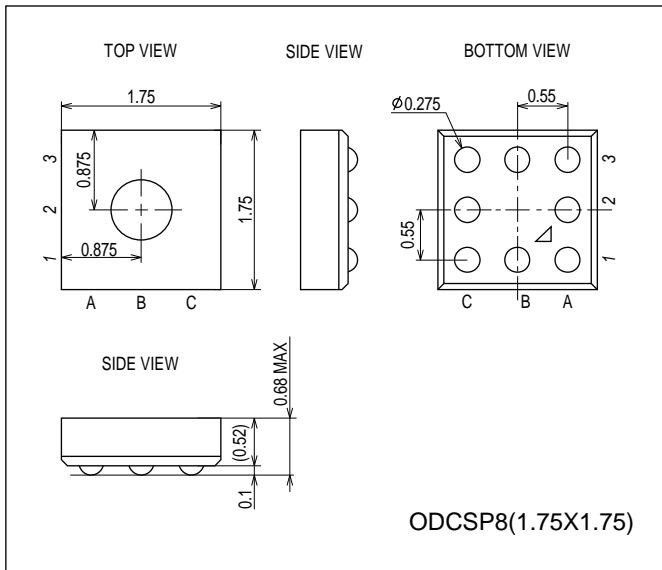

## Pin Assignment

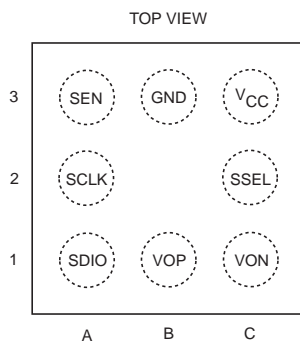

Pin No.	Pin name	Function
1A	SDIO	Serial communication Data pin
1B	VOP	Positive side output pin
1C	VON	Negative side output pin
2A	SCLK	Serial communication Clock pin
2C	SSEL	Register selection pin SSEL = Low, Open : Address 00 to 0Fh used SSEL = High : Address 10 to 1Fh used
3A	SEN	Serial communication Enable pin
3B	GND	GND pin
3C	VCC	Power supply voltage pin

## PD assignment

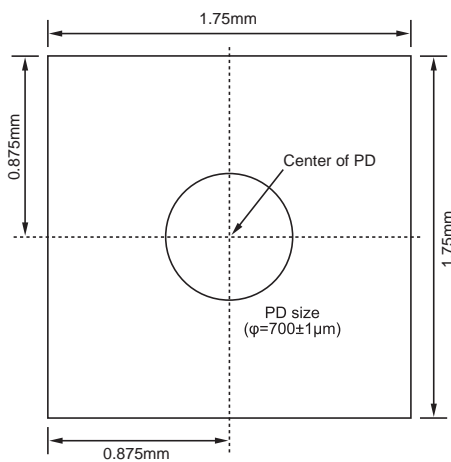

\*PD size for reference to be used for design

# LV0221CS

## Block diagram and Test circuit diagram

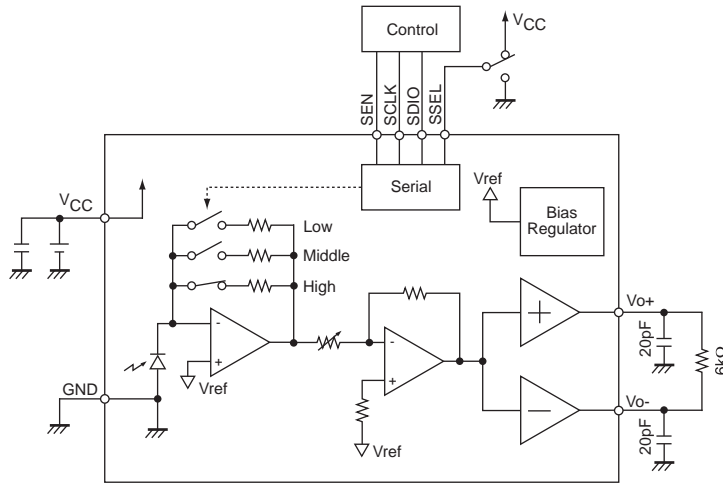

## Resister table

Enable selection of the register group from the SSEL pin.

**SSEL = Low, Open**

	Address	7	6	5	4	3	2	1	0
Name	00h	POWER			IV GAIN SEL		GAIN SEL		
Default		00			00		00		
Value		11: Power on 00 01 10: Sleep			00 01: High 10: Middle 11: Low		00 01: BD 10: DVD 11: CD		
Name	01h	BD GAIN							
Default		1	1	1	1	1	1	1	1
Value		00000000 to 11111111							
Name	02h	DVD GAIN							
Default		1	1	1	1	1	1	1	1
Value		00000000 to 11111111							
Name	03h	CD GAIN							
Default		1	1	1	1	1	1	1	1
Value		00000000 to 11111111							
Name	0Eh	TEST1 (*1)							
Name	0Fh	TEST2 (*1)							

**SSEL = High**

	Address	7	6	5	4	3	2	1	0
Name	10h	POWER			IV GAIN SEL		GAIN SEL		
Default		00			00		00		
Value		11: Power on 00 01 10: Sleep			00 01: High 10: Middle 11: Low		00 01: BD 10: DVD 11: CD		
Name	11h	BD GAIN							
Default		1	1	1	1	1	1	1	1
Value		00000000 to 11111111							
Name	12h	DVD GAIN							
Default		1	1	1	1	1	1	1	1
Value		00000000 to 11111111							
Name	13h	CD GAIN							
Default		1	1	1	1	1	1	1	1
Value		00000000 to 11111111							
Name	1Eh	TEST1 (*1)							
Name	1Fh	TEST2 (*1)							

\*1 TEST1 and TEST2 are either the time when power is applied or "00000000" is set. Do not attempt to change "00000000" during operation. "00000000" is returned when reading is made.

\*2 No problem in terms of operation occurs even when writing is made to the address 04h to 0Dh and 14h to 1Dh. "00000000" is returned when this address is read.

## Serial protocol

WRITE timing chart

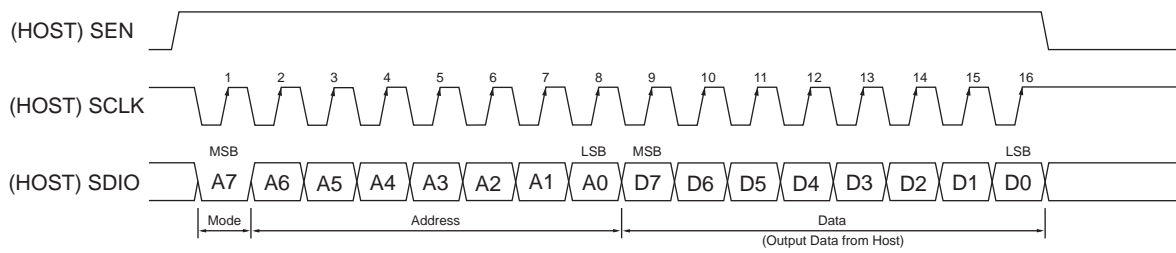

READ timing chart

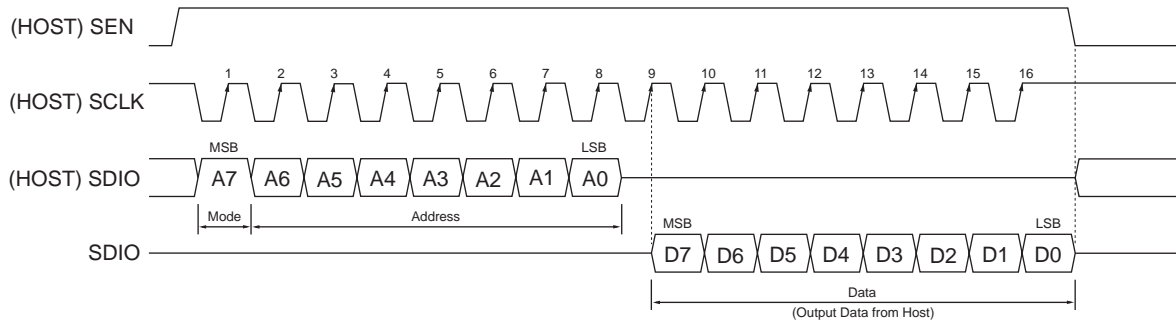

SDIO pin load / CL=20pF (The table below shows the design reference value.)

Parameter	Symbol	Min.	Typ.	Max.	Unit
SCL clock frequency Write	$f_{SCL}$	0		10	MHz
SCL clock frequency Read	$f_{SCL}$	0		4	MHz
SDIO data setup time	$t_{DSU}$	50			ns
SDIO data hold time	$t_{DHO}$	50			ns
SDIO output delay	$t_{DDLY}$		10	80	ns
SEN "H" period	$t_{ENH}$	1.6			$\mu$ s
SEN "L" period	$t_{ENL}$	200			ns
SCL rise time after SEN rise	$t_{STA}$	60			ns
SEN fall time after final SCL rise	$t_{STO}$	100			ns
Serial input "H" voltage	$V_{IH}$	2.4			V
Serial input "L" voltage	$V_{IL}$			0.6	V
SDIO output "H" voltage	$V_{OH}$	2.5	2.9	3.3	V
SDIO output "L" voltage	$V_{OL}$	0	0.3	0.8	V

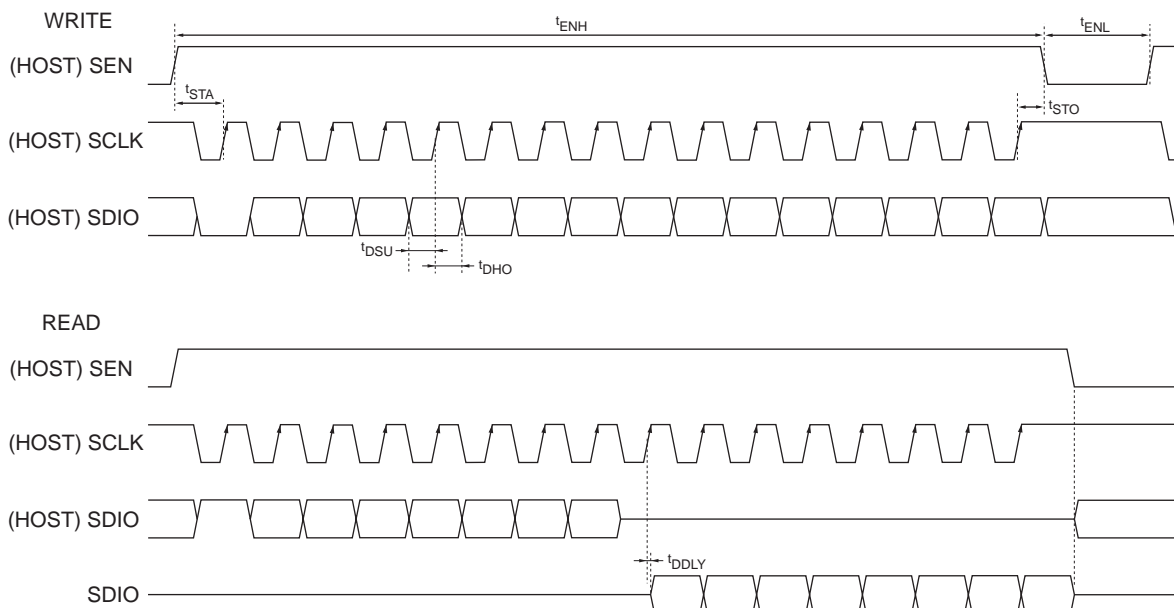

# LV0221CS

Pin	Type	Equivalent circuit diagram
SDIO	Input Output	
VOP VON	Output	
SCLK SSEL SEN	Input	

ON Semiconductor and the ON logo are registered trademarks of Semiconductor Components Industries, LLC (SCILLC). SCILLC owns the rights to a number of patents, trademarks, copyrights, trade secrets, and other intellectual property. A listing of SCILLC's product/patent coverage may be accessed at [www.onsemi.com/site/pdf/Patent-Marking.pdf](http://www.onsemi.com/site/pdf/Patent-Marking.pdf). SCILLC reserves the right to make changes without further notice to any products herein. SCILLC makes no warranty, representation or guarantee regarding the suitability of its products for any particular purpose, nor does SCILLC assume any liability arising out of the application or use of any product or circuit, and specifically disclaims any and all liability, including without limitation special, consequential or incidental damages. "Typical" parameters which may be provided in SCILLC data sheets and/or specifications can and do vary in different applications and actual performance may vary over time. All operating parameters, including "Typicals" must be validated for each customer application by customer's technical experts. SCILLC does not convey any license under its patent rights nor the rights of others. SCILLC products are not designed, intended, or authorized for use as components in systems intended for surgical implant into the body, or other applications intended to support or sustain life, or for any other application in which the failure of the SCILLC product could create a situation where personal injury or death may occur. Should Buyer purchase or use SCILLC products for any such unintended or unauthorized application, Buyer shall indemnify and hold SCILLC and its officers, employees, subsidiaries, affiliates, and distributors harmless against all claims, costs, damages, and expenses, and reasonable attorney fees arising out of, directly or indirectly, any claim of personal injury or death associated with such unintended or unauthorized use, even if such claim alleges that SCILLC was negligent regarding the design or manufacture of the part. SCILLC is an Equal Opportunity/Affirmative Action Employer. This literature is subject to all applicable copyright laws and is not for resale in any manner.

Компания «Life Electronics» занимается поставками электронных компонентов импортного и отечественного производства от производителей и со складов крупных дистрибьюторов Европы, Америки и Азии.

С конца 2013 года компания активно расширяет линейку поставок компонентов по направлению коаксиальный кабель, кварцевые генераторы и конденсаторы (керамические, пленочные, электролитические), за счёт заключения дистрибьюторских договоров

Мы предлагаем:

- Конкурентоспособные цены и скидки постоянным клиентам.
- Специальные условия для постоянных клиентов.
- Подбор аналогов.
- Поставку компонентов в любых объемах, удовлетворяющих вашим потребностям.
- Приемлемые сроки поставки, возможна ускоренная поставка.
- Доставку товара в любую точку России и стран СНГ.
- Комплексную поставку.
- Работу по проектам и поставку образцов.
- Формирование склада под заказчика.
- Сертификаты соответствия на поставляемую продукцию (по желанию клиента).
- Тестирование поставляемой продукции.
- Поставку компонентов, требующих военную и космическую приемку.
- Входной контроль качества.
- Наличие сертификата ISO.

В составе нашей компании организован Конструкторский отдел, призванный помогать разработчикам, и инженерам.

Конструкторский отдел помогает осуществить:

- Регистрацию проекта у производителя компонентов.
- Техническую поддержку проекта.
- Защиту от снятия компонента с производства.
- Оценку стоимости проекта по компонентам.
- Изготовление тестовой платы монтаж и пусконаладочные работы.



Тел: +7 (812) 336 43 04 (многоканальный)  
Email: [org@lifeelectronics.ru](mailto:org@lifeelectronics.ru)