

### Features

- High speed 1Mbit/s
- High isolation voltage between input and output (Viso=5000 Vrms )
- Guaranteed performance from 0°C to 70 °C
- Wide operating temperature range of -55°C to 100 °C
- Pb free and RoHS compliant
- UL approved (No. 214129)
- VDE approved (No. 132249)
- SEMKO approved
- NEMKO approved
- DEMKO approved
- FIMKO approved
- CSA approved (No. 2037145)

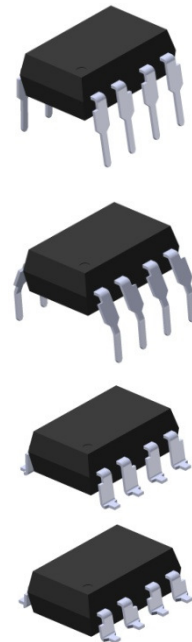

### Description

The 6N135, 6N136, EL4502 and EL4503 devices each consist of an infrared emitting diode, optically coupled to a high speed photo detector transistor. A separate connection for the photodiode bias and output-transistor collector increase the speed by several orders of magnitude over conventional phototransistor couplers by reducing the base-collector capacitance of the input transistor.

The devices are packaged in an 8-pin DIP package and available in wide-lead spacing and SMD option.

### Applications

- Line receivers
- Telecommunication equipments
- Power transistor isolation in motor drives
- Replacement for low speed phototransistor photo couplers
- Feedback loop in switch-mode power supplies
- Home appliances
- High speed logic ground isolation

### Schematic

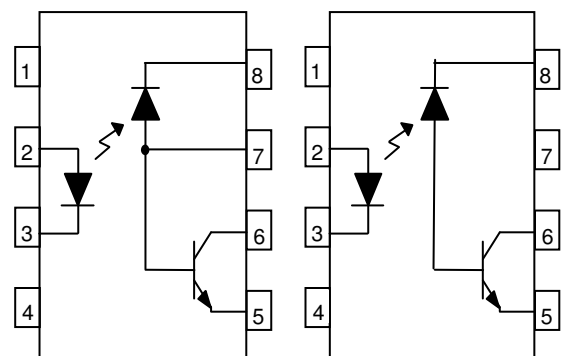

6N135 / 6N136

EL4502 / EL4503

#### Pin Configuration

1. No Connection
2. Anode
3. Cathode
4. No Connection
5. Gnd
6. Vout
7. V<sub>B</sub>
8. V<sub>CC</sub>

#### Pin Configuration

1. No Connection
2. Anode
3. Cathode
4. No Connection
5. Gnd
6. Vout
7. No Connection
8. V<sub>CC</sub>

### Absolute Maximum Ratings (T<sub>a</sub>=25°C)

Parameter		Symbol	Rating	Unit
Input	Forward current	I <sub>F</sub>	25	mA
	Peak forward current (50% duty, 1ms P.W)	I <sub>FP</sub>	50	mA
	Peak transient current (≤1μs P.W,300pps)	I <sub>Ftrans</sub>	1	A
	Reverse voltage	V <sub>R</sub>	5	V
	Power dissipation	P <sub>IN</sub>	45	mW
Output	Power dissipation	P <sub>O</sub>	100	mW
	Emitter-Base reverse voltage	6N135 6N136 V <sub>EBR</sub>	5	V
	Base current	6N135 6N136 I <sub>B</sub>	5	mA
	Average Output current	I <sub>O(AVG)</sub>	8	mA
	Peak Output current	I <sub>O(PK)</sub>	16	mA
	Output voltage	V <sub>O</sub>	-0.5 to 20	V
	Supply voltage	V <sub>CC</sub>	-0.5 to 30	V
Isolation voltage *1		V <sub>ISO</sub>	5000	V rms
Operating temperature		T <sub>OPR</sub>	-55 ~ +100	°C
Storage temperature		T <sub>STG</sub>	-55 ~ +125	°C
Soldering temperature *2		T <sub>SOL</sub>	260	°C

#### Notes

\*1 AC for 1 minute, R.H.= 40 ~ 60% R.H. In this test, pins 1, 2, 3, 4 are shorted together, and pins 5, 6, 7, 8 are shorted together.

\*2 For 10 seconds.

### Electrical Characteristics ( $T_A=0$ to $70^\circ\text{C}$ unless specified otherwise)

#### Input

Parameter	Symbol	Min.	Typ.*	Max.	Unit	Conditions
Forward voltage	$V_F$	-	1.45	1.8	V	$I_F = 16\text{mA}$
Reverse Voltage	$V_R$	5.0	-	-	V	$I_R = 10\mu\text{A}$
Temperature coefficient of forward voltage	$\Delta V_F/\Delta T_A$	-	-1.9	-	mV/ $^\circ\text{C}$	$I_F = 16\text{mA}$

#### Output

Parameter	Symbol	Min.	Typ.*	Max.	Unit	Conditions
Logic High Output Current	$I_{OH}$	-	0.001	0.5	$\mu\text{A}$	$I_F=0\text{mA}, V_O=V_{CC}=5.5\text{V}, T_A=25^\circ\text{C}$
		-	0.01	1		$I_F=0\text{mA}, V_O=V_{CC}=15\text{V}, T_A=25^\circ\text{C}$
		-	-	50		$I_F=0\text{mA}, V_O=V_{CC}=15\text{V}$
Logic Low Supply Current	$I_{CCL}$	-	140	200	$\mu\text{A}$	$I_F=16\text{mA}, V_O=\text{Open}, V_{CC}=15\text{V}$
Logic High Supply Current	$I_{CCH}$	-	0.01	1	$\mu\text{A}$	$I_F=0\text{mA}, V_O=\text{Open}, V_{CC}=15\text{V}, T_A=25^\circ\text{C}$
		-	-	2		$I_F=0\text{mA}, V_O=\text{Open}, V_{CC}=15\text{V}$

\* Typical values at  $T_A = 25^\circ\text{C}$

### Transfer Characteristics ( $T_A=0$ to $70^\circ\text{C}$ unless specified otherwise)

Parameter		Symbol	Min.	Typ.*	Max.	Unit	Conditions
Current Transfer Ratio	6N135	CTR	7	-	50	%	$I_F = 16\text{mA}, V_O = 0.4\text{V}, V_{CC}=4.5\text{V}, T_A=25^\circ\text{C}$
	6N136 EL4502 EL4503		19	-	50		
	6N135		5	-	-		$I_F = 16\text{mA}, V_O = 0.4\text{V}, V_{CC}=4.5\text{V}$
	6N136 EL4502 EL4503		15	-	-		
Logic Low Output Voltage	6N135	$V_{OL}$	-	0.18	0.4	V	$I_F = 16\text{mA}, I_O = 1.1\text{mA}, V_{CC}=4.5\text{V}, T_A=25^\circ\text{C}$
	6N136 EL4502 EL4503		-	0.25	0.4		$I_F = 16\text{mA}, I_O = 3\text{mA}, V_{CC}=4.5\text{V}, T_A=25^\circ\text{C}$
	6N135		-	-	0.5		$I_F = 16\text{mA}, I_O = 0.8\text{mA}, V_{CC}=4.5\text{V}$
	6N136 EL4502 EL4503		-	-	0.5		$I_F=16\text{mA}, I_O=2.4\text{mA}, V_{CC}=4.5\text{V}$

### Switching Characteristics ( $T_A=0$ to $70^\circ\text{C}$ unless specified otherwise, $I_F=16\text{mA}$ , $V_{CC}=5\text{V}$ )

Parameter		Symbol	Min.	Typ.*	Max.	Unit	Conditions
Propagation Delay Time to Logic Low (Fig.8)	6N135	TPHL	-	0.35	1.5	$\mu\text{s}$	$R_L=4.1\text{K}\Omega$ , $T_A=25^\circ\text{C}$
			-	-	2.0		$R_L=4.1\text{K}\Omega$
	6N136 EL4502 EL4503		-	0.35	0.8		$R_L=1.9\text{K}\Omega$ , $T_A=25^\circ\text{C}$
			-	-	1.0		$R_L=1.9\text{K}\Omega$
Propagation Delay Time to Logic High (Fig.8)	6N135	TPLH	-	0.5	1.5	$\mu\text{s}$	$R_L=4.1\text{K}\Omega$ , $T_A=25^\circ\text{C}$
			-	-	2.0		$R_L=4.1\text{K}\Omega$
	6N136 EL4502 EL4503		-	0.3	0.8		$R_L=1.9\text{K}\Omega$ , $T_A=25^\circ\text{C}$
			-	-	1.0		$R_L=1.9\text{K}\Omega$
Common Mode Transient Immunity at Logic High (Fig.9) <sup>*3</sup>	6N135	$\text{CM}_H$	1,000	-	-	$\text{V}/\mu\text{s}$	$I_F = 0\text{mA}$ , $V_{CM}=10\text{Vp-p}$ , $R_L=4.1\text{K}\Omega$ , $T_A = 25^\circ\text{C}$
	6N136 EL4502		1,000	-	-		$I_F = 0\text{mA}$ , $V_{CM}=10\text{Vp-p}$ , $R_L=1.9\text{K}\Omega$ , $T_A = 25^\circ\text{C}$
	EL4503		15000	20000	-		$I_F = 0\text{mA}$ , $V_{CM}=1500\text{Vp-p}$ , $R_L=1.9\text{K}\Omega$ , $T_A = 25^\circ\text{C}$
Common Mode Transient Immunity at Logic Low (Fig.9) <sup>*3</sup>	6N135	$\text{CM}_L$	1,000	-	-	$\text{V}/\mu\text{s}$	$I_F = 16\text{mA}$ , $V_{CM}=10\text{Vp-p}$ , $R_L=4.1\text{K}\Omega$ , $T_A = 25^\circ\text{C}$
	6N136 EL4502		1,000	-	-		$I_F = 16\text{mA}$ , $V_{CM}=10\text{Vp-p}$ , $R_L=1.9\text{K}\Omega$ , $T_A=25^\circ\text{C}$
	EL4503		15000	20000	-		$I_F = 0\text{mA}$ , $V_{CM}=1500\text{Vp-p}$ , $R_L=1.9\text{K}\Omega$ , $T_A = 25^\circ\text{C}$

\* Typical values at  $T_A = 25^\circ\text{C}$

### Typical Performance Curves

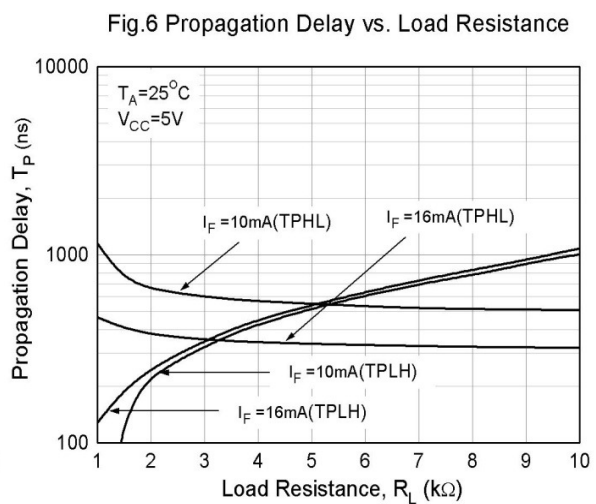
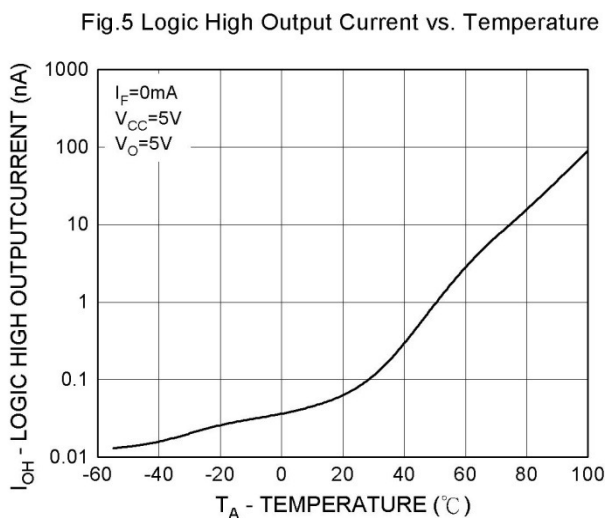
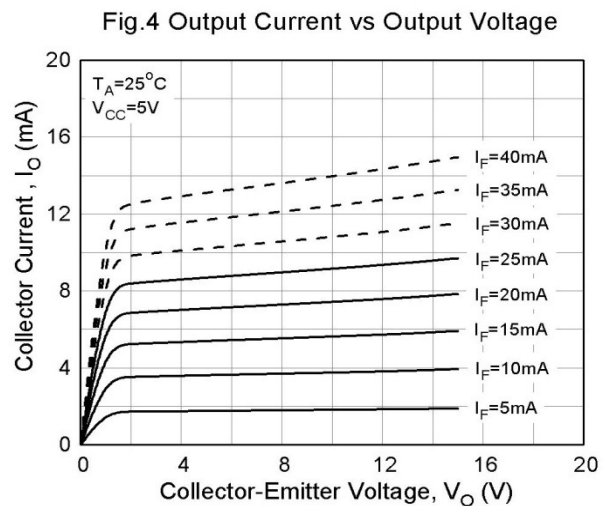
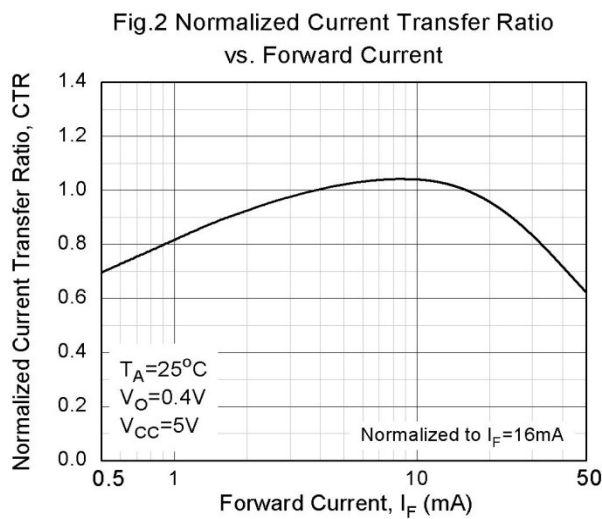
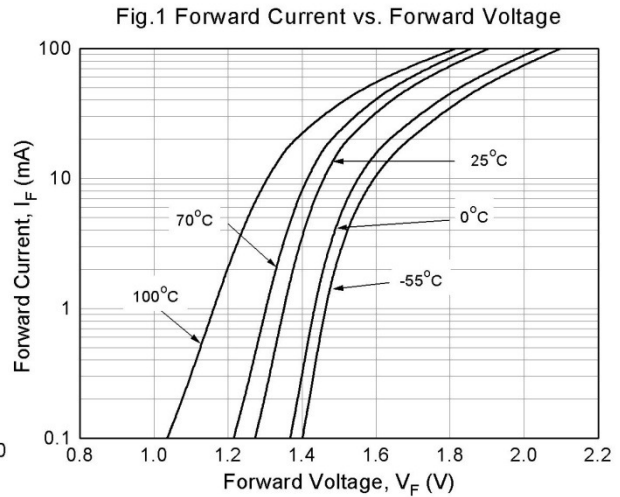
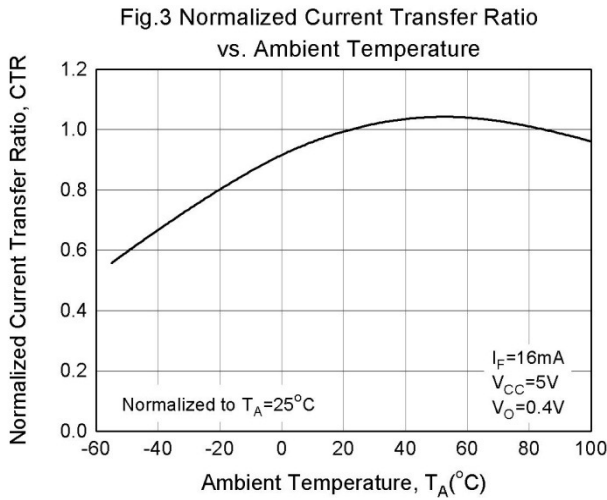

Fig.7 Propagation Delay vs. Temperature

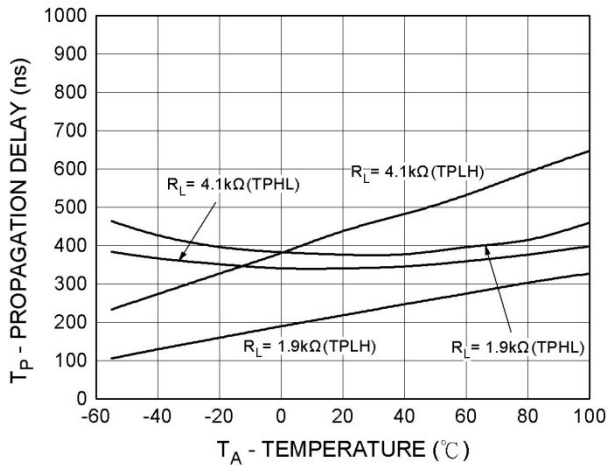

Figure 8 Switching Time Test Circuit & Waveform

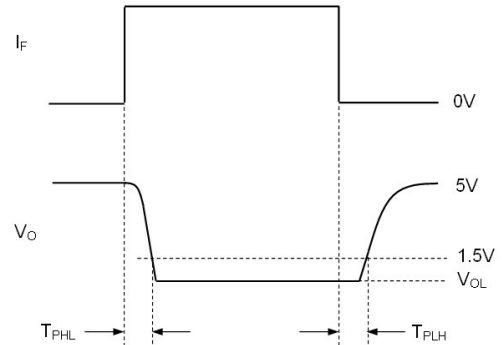
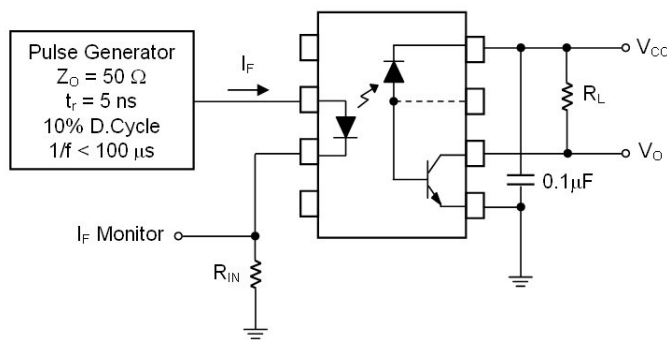
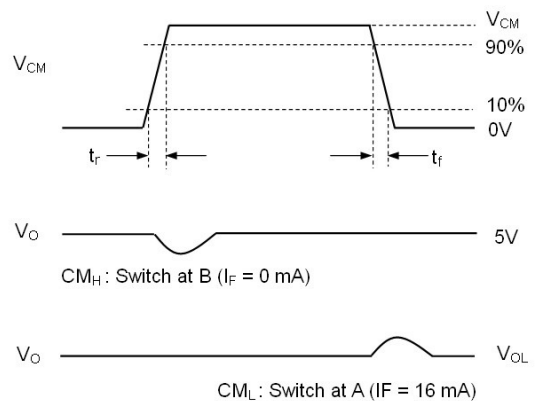
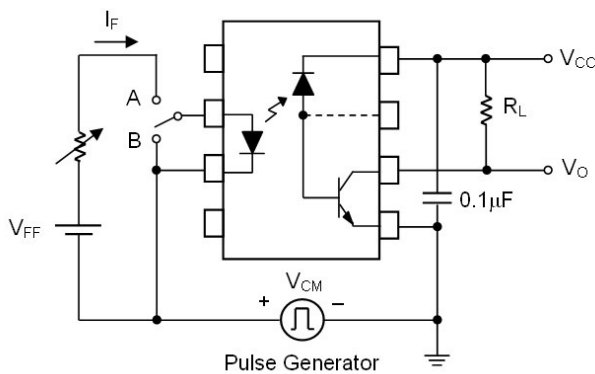

Figure 9 Transient Immunity Test Circuit &



**Note:**

\*3 Common mode transient immunity in logic high level is the maximum tolerable (positive)  $dV_{cm}/dt$  on the leading edge of the common mode pulse signal  $V_{CM}$ , to assure that the output will remain in a logic high state (i.e.,  $V_O > 2.0V$ ).

Common mode transient immunity in logic low level is the maximum tolerable (negative)  $dV_{cm}/dt$  on the trailing edge of the common mode pulse signal,  $V_{CM}$ , to assure that the output will remain in a logic low state (i.e.,  $V_O < 0.8V$ ).

### Order Information

#### Part Number

**6N13XY(Z)-V**

or

**EL450XY(Z)-V**

#### Note

X = Part No. (X = 5 or 6) for 6N series; (X=2 or 3) for EL45 series

Y = Lead form option (S, S1, M or none)

Z = Tape and reel option (TA, TB or none)

V = VDE (optional)

Option	Description	Packing quantity
None	Standard DIP-8	45 units per tube
M	Wide lead bend (0.4 inch spacing)	45 units per tube
S (TA)	Surface mount lead form + TA tape & reel option	1000 units per reel
S (TB)	Surface mount lead form + TB tape & reel option	1000 units per reel
S1 (TA)	Surface mount lead form (low profile) + TA tape & reel option	1000 units per reel
S1 (TB)	Surface mount lead form (low profile) + TB tape & reel option	1000 units per reel



### Package Drawing (Dimensions in mm)

#### Standard DIP Type

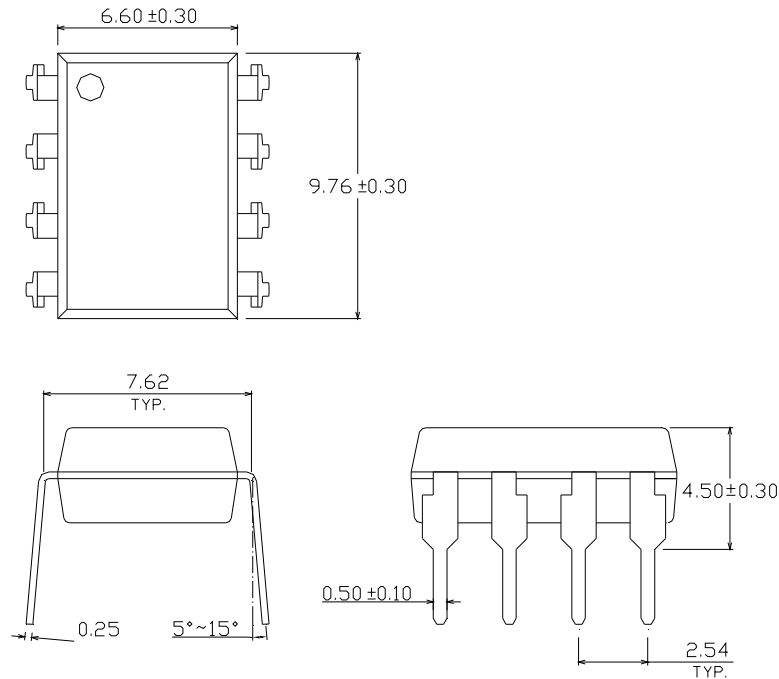

#### Option M Type

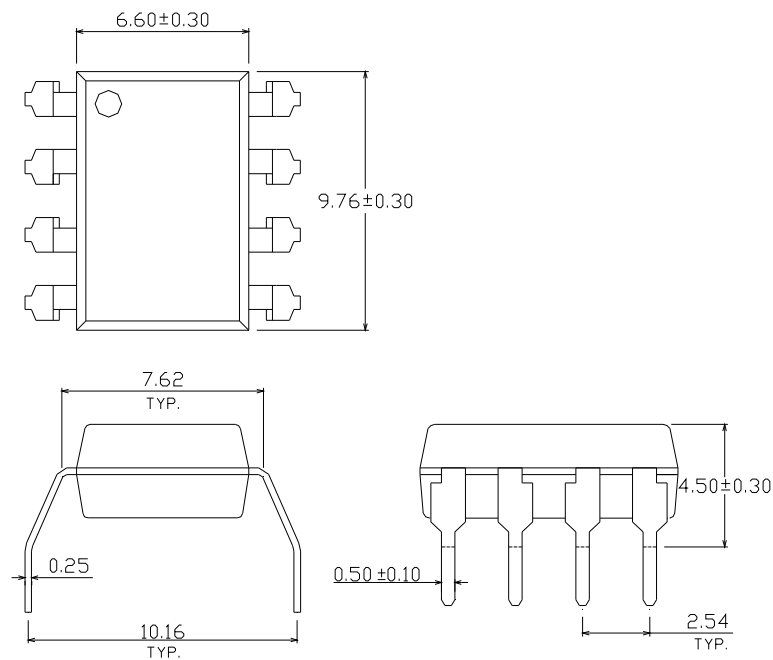

### Option S Type

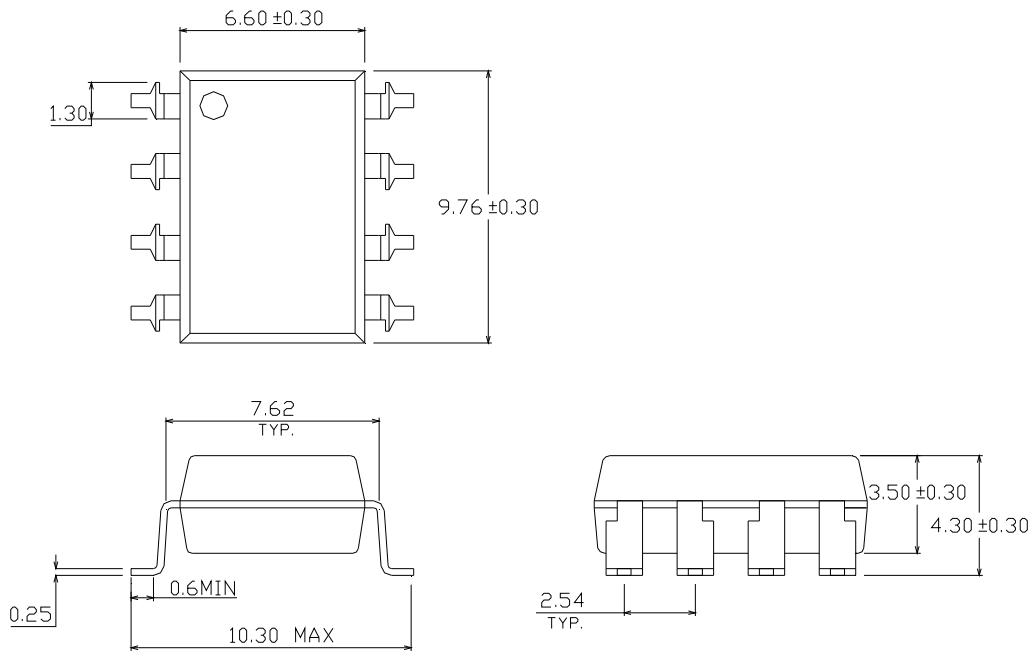

### Option S1 Type

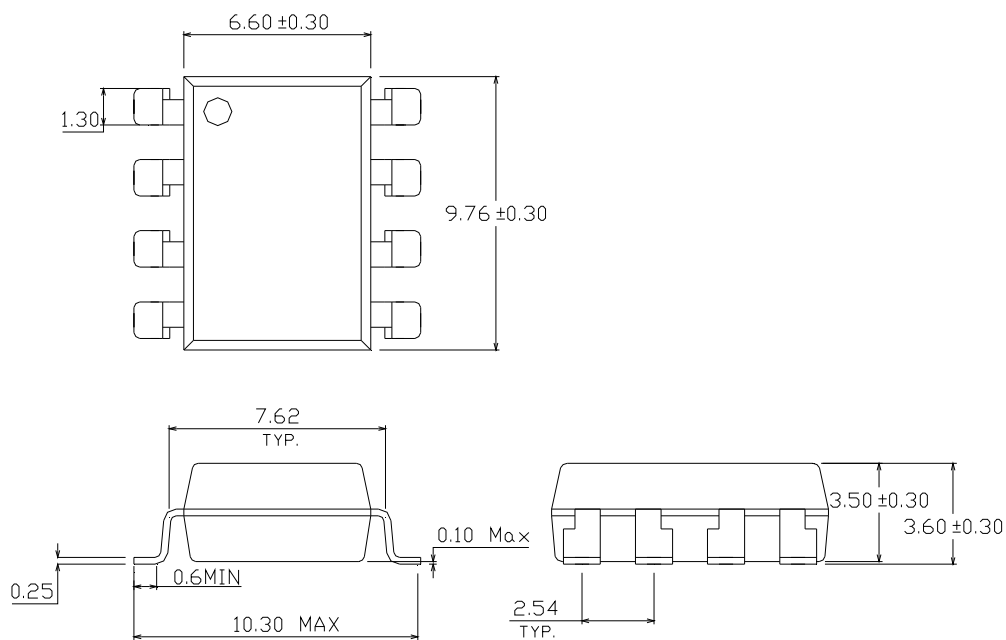

### Recommended pad layout for surface mount leadform

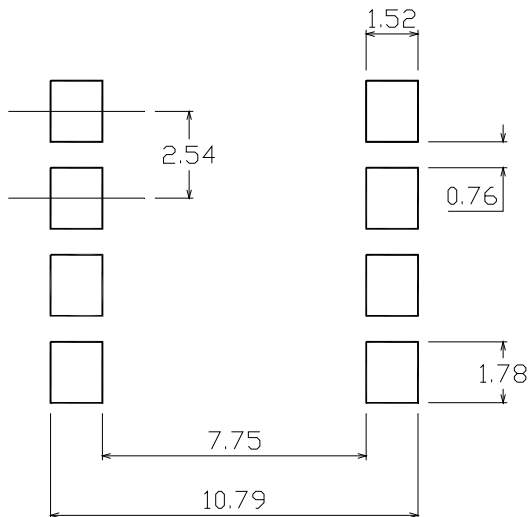

### Device Marking

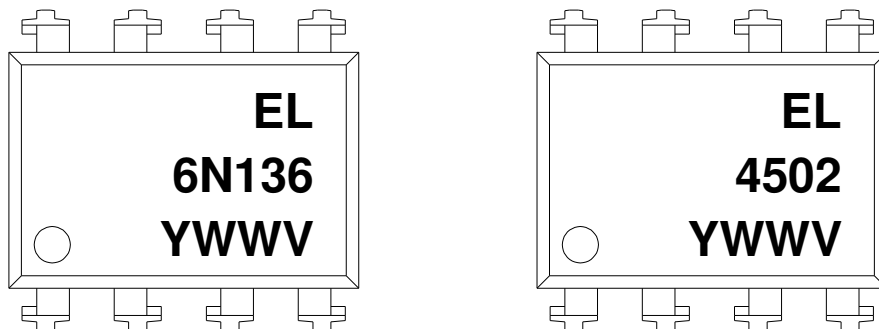

### Notes

4502

6N136 denotes Device Number

Y denotes 1 digit Year code

WW denotes 2 digit Week code

V denotes VDE (optional)

### Tape & Reel Packing Specifications

#### Option TA

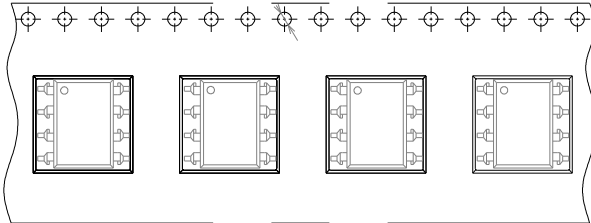

Direction of feed from reel

#### Option TB

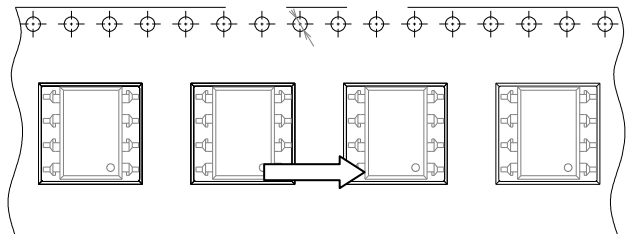

Direction of feed from reel

### Tape dimensions

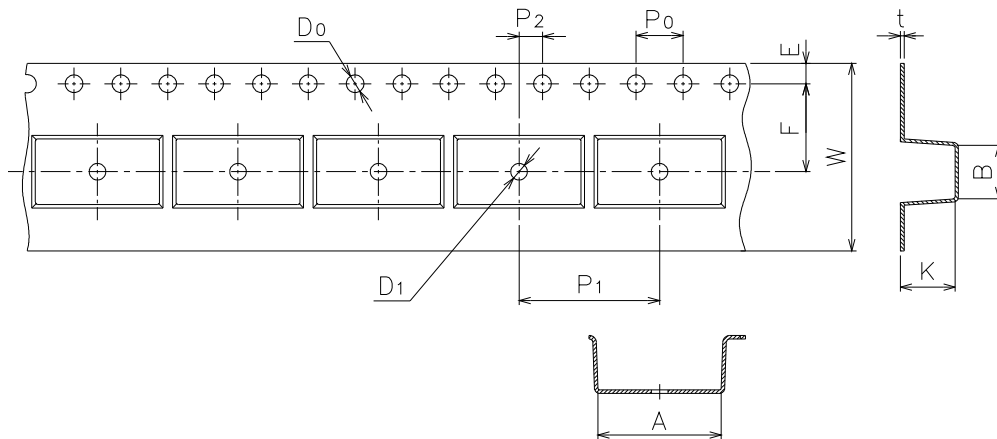

Dimension No.	<b>A</b>	<b>B</b>	<b>Do</b>	<b>D1</b>	<b>E</b>	<b>F</b>
Dimension(mm)	10.4±0.1	10.0±0.1	1.5±0.1	1.5±0.1	1.75±0.1	7.5±0.1
Dimension No.	<b>Po</b>	<b>P1</b>	<b>P2</b>	<b>t</b>	<b>W</b>	<b>K</b>
Dimension(mm)	4.0±0.1	12.0±0.1	2.0±0.1	0.4±0.1	16.0+0.3/ -0.1	4.5±0.1

### Solder Reflow Temperature Profile

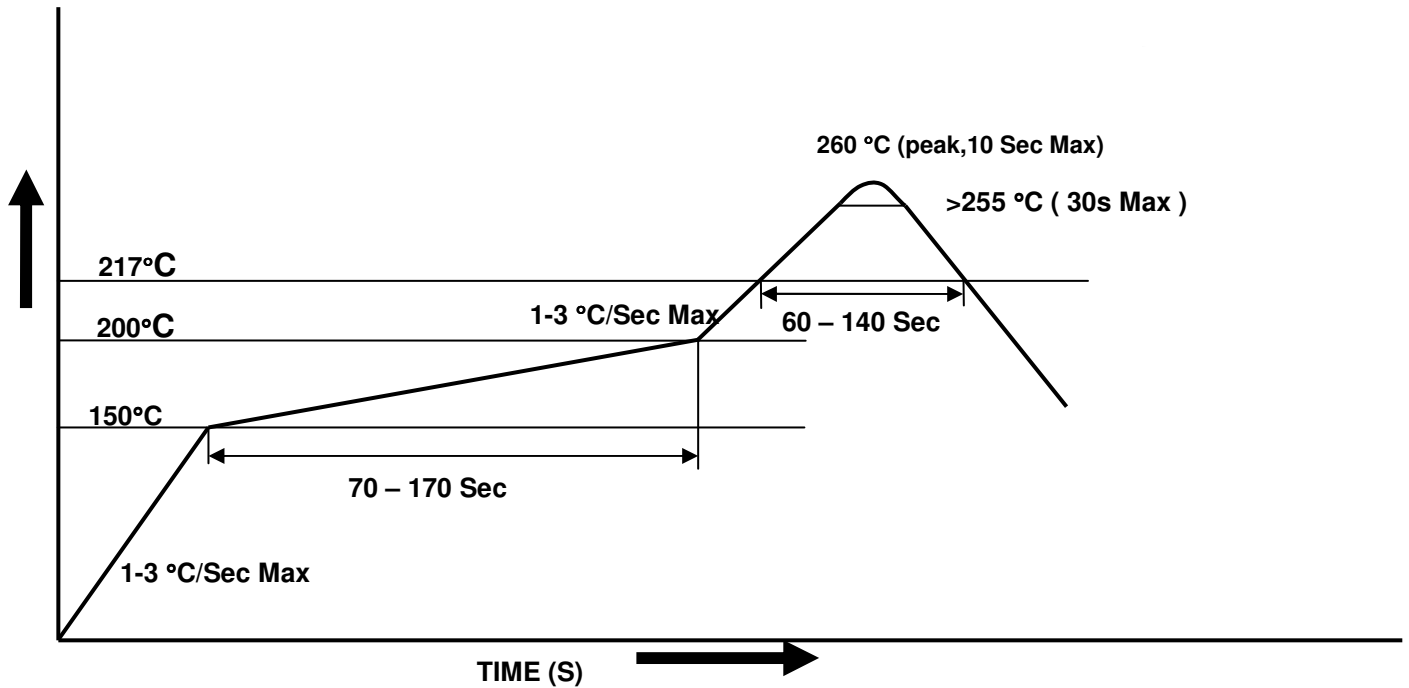

### DISCLAIMER

1. Above specification may be changed without notice. EVERLIGHT will reserve authority on material change for above specification.
2. When using this product, please observe the absolute maximum ratings and the instructions for using outlined in these specification sheets. EVERLIGHT assumes no responsibility for any damage resulting from use of the product which does not comply with the absolute maximum ratings and the instructions included in these specification sheets.
3. These specification sheets include materials protected under copyright of EVERLIGHT corporation. Please don't reproduce or cause anyone to reproduce them without EVERLIGHT's consent.

Компания «Life Electronics» занимается поставками электронных компонентов импортного и отечественного производства от производителей и со складов крупных дистрибьюторов Европы, Америки и Азии.

С конца 2013 года компания активно расширяет линейку поставок компонентов по направлению коаксиальный кабель, кварцевые генераторы и конденсаторы (керамические, пленочные, электролитические), за счёт заключения дистрибьюторских договоров

Мы предлагаем:

- Конкурентоспособные цены и скидки постоянным клиентам.
- Специальные условия для постоянных клиентов.
- Подбор аналогов.
- Поставку компонентов в любых объемах, удовлетворяющих вашим потребностям.
- Приемлемые сроки поставки, возможна ускоренная поставка.
- Доставку товара в любую точку России и стран СНГ.
- Комплексную поставку.
- Работу по проектам и поставку образцов.
- Формирование склада под заказчика.
- Сертификаты соответствия на поставляемую продукцию (по желанию клиента).
- Тестирование поставляемой продукции.
- Поставку компонентов, требующих военную и космическую приемку.
- Входной контроль качества.
- Наличие сертификата ISO.

В составе нашей компании организован Конструкторский отдел, призванный помогать разработчикам, и инженерам.

Конструкторский отдел помогает осуществить:

- Регистрацию проекта у производителя компонентов.
- Техническую поддержку проекта.
- Защиту от снятия компонента с производства.
- Оценку стоимости проекта по компонентам.
- Изготовление тестовой платы монтаж и пусконаладочные работы.



Тел: +7 (812) 336 43 04 (многоканальный)

Email: [org@lifeelectronics.ru](mailto:org@lifeelectronics.ru)