



Si3406x Family Data Sheet

Fully-Integrated IEEE 802.3-Compliant POE+ PD Interface and High-Efficiency Switching Regulators with Sleep, Wake, and LED Drive

The Si3406x family integrates all power management and control functions required in a Power-over-Ethernet Plus (PoE+) powered device (PD) application. These devices convert the high voltage supplied over the 10/100/1000BASE-T Ethernet connection to a regulated, low-voltage output supply. The optimized architecture of this device family minimizes the solution footprint and external BOM cost and enables the use of low-cost external components while maintaining high performance. The Si3406x family integrates the required diode bridges and transient surge suppressor, thus enabling direct connection of the IC to the Ethernet RJ-45 connector. The switching power FET and all associated functions are also integrated. The integrated, current mode controlled switching regulator supports isolated or non-isolated flyback and buck converter topologies. The switching frequency for the regulator is tunable with a simple external resistor value to help avoid unwanted harmonics for better emissions control. A synchronous driver is provided to optionally drive a secondary side FET to improve efficiency of power conversion. Connection to the PSE switch is maintained during sleep by an optional automated maintain-power-signature (MPS) signal.

These devices fully support the IEEE 802.3at specification for the cases of single or two event classification. Standard external resistors provide the proper IEEE 802.3 signatures for the detection function and programming of the classification mode, and internal startup circuits ensure well-controlled soft-start initial operation of both the hotswap switch and the voltage regulator.

The Si34061 and Si34062 add main transformer bias winding support for ultra-high-efficiency operation.

The Si34062 includes support for sleep modes with wake function, as well as LED drive capability. These features can be utilized to minimize standby current, control sleep and wake states, and provide application status information using an LED.

The Si3406 is available in a low-profile, 20-pin, 5 x 5 mm QFN package, and the Si34061 and Si34062 are available in low-profile, 24-pin, 5 x 5 mm QFN packages.

KEY FEATURES

- Type 1 (PoE) or Type 2 (PoE+) power
- Full IEEE 802.3at compliance
- Synchronous secondary FET driver
- Current mode dc-dc converter
- Tunable switching frequency
- Auxiliary transformer winding support
- Auxiliary wall adapter support (12 V to 57 V)
- Internal hotswap and switching FET bypass support
- Automated maintain-power-signature (MPS) support
- Sleep mode augmented with wake pin, mode control, and LED driver
- 120 V Absolute Max voltage performance
- Extended -40 to +85 °C temperature
- Compact ROHS-compliant 5 mm x 5 mm QFN Package

APPLICATIONS

- Voice over IP telephones
- Wireless access points
- Security and surveillance IP cameras
- Lighting luminaires
- Point-of-sale terminals
- Internet appliances
- Network devices

1. Ordering Guide

Table 1.1. Si3406x Ordering Guide

| Ordering Part Number | Package | Temperature Range (Ambient) | Applications |
|----------------------|--------------------------------------------|-----------------------------|-------------------------------------------------------------------------------------|
| Si3406-A-GM | 5 x 5 mm 20-QFN Pb-free, RoHS-compliant | –40 to 85 °C Extended | All Purposes |
| Si34061-A-GM | 5 x 5 mm 24-QFN Pb-free, RoHS-compliant | –40 to 85 °C Extended | Any high-power, high-efficiency uses, such as Wireless Access Points and IP Cameras |
| Si34062-A-GM | 5 x 5 mm 24-QFN Pb-free, RoHS-compliant | –40 to 85 °C Extended | IP Phones with manual sleep mode |

Table of Contents

| | |
|------------------------------------------------------------------------------------------------|-----------|
| 1. Ordering Guide | 2 |
| 2. System Overview | 4 |
| 2.1 Block Diagrams | 4 |
| 2.2 Power over Ethernet (PoE) Line-Side Interface | 5 |
| 2.2.1 Surge Protection | 5 |
| 2.2.2 Telephony Protection | 5 |
| 2.2.3 Detection and Classification | 6 |
| 2.3 Hotswap Switch | 6 |
| 2.4 HSSW State Machine | 7 |
| 2.4.1 External HSSW FET Driver | 7 |
| 2.5 DC to DC Converter | 8 |
| 2.5.1 Average Current Sensing, Overcurrent, Low-Current Detection, and Output Short Protection | 9 |
| 2.5.2 Sync FET Driver | 9 |
| 2.6 Tunable Oscillator | 9 |
| 2.7 Regulators | 10 |
| 2.8 Sleep Mode | 10 |
| 2.9 Special Sleep Mode | 10 |
| 2.10 External Wall Adapter Support | 11 |
| 3. Application Examples | 12 |
| 4. Electrical Specifications | 14 |
| 5. Pin Descriptions | 19 |
| 5.1 Detailed Pin Descriptions | 21 |
| 6. Packaging | 26 |
| 6.1 Package Outline: Si3406 | 26 |
| 6.2 Land Pattern: Si3406 | 28 |
| 6.3 Package Outline: Si34061/62 | 29 |
| 6.4 Land Pattern: Si34061/62 | 31 |
| 7. Top Markings | 32 |
| 7.1 Si3406 Top Marking | 32 |
| 7.2 Si34061 Top Marking | 33 |
| 7.3 Si34062 Top Marking | 34 |
| 8. Revision History | 35 |

2. System Overview

The following Block Diagrams will give the designer a sense for the internal arrangement of functional blocks, plus their relationships to external pins. The Block Diagrams are followed by a description of the features of these integrated circuits.

2.1 Block Diagrams

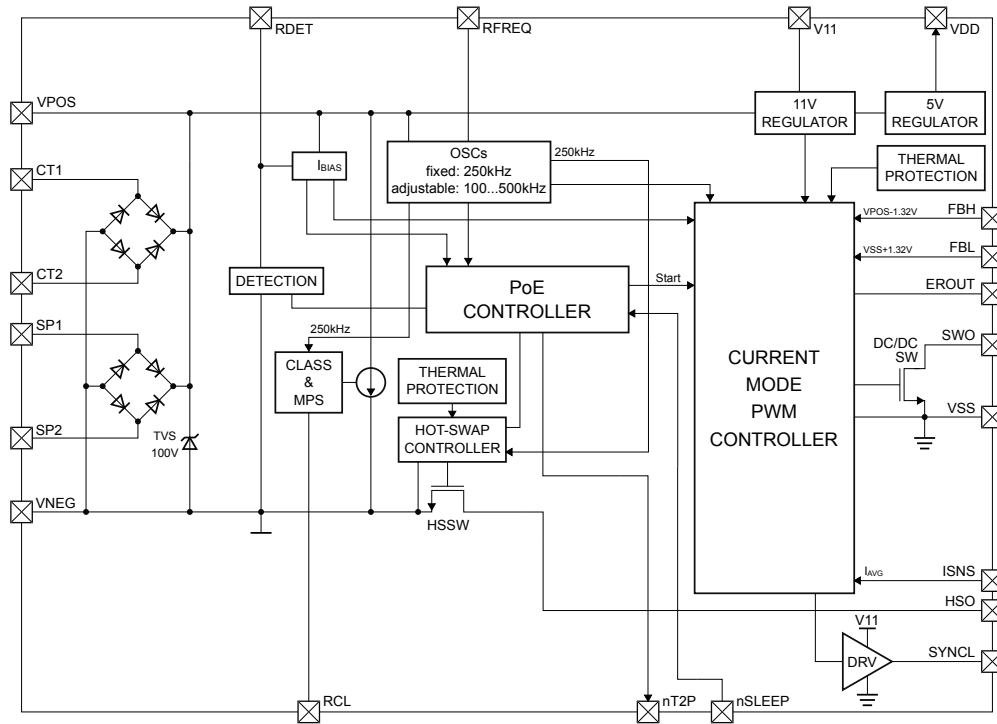

Figure 2.1. Si3406 Block Diagram

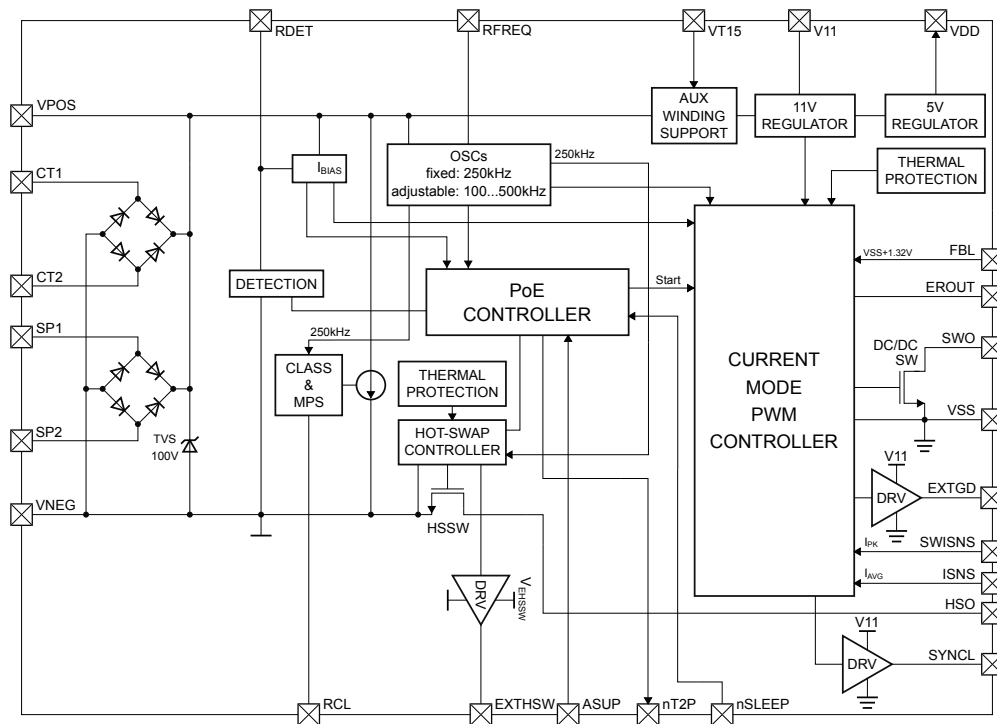

Figure 2.2. Si34061 Block Diagram

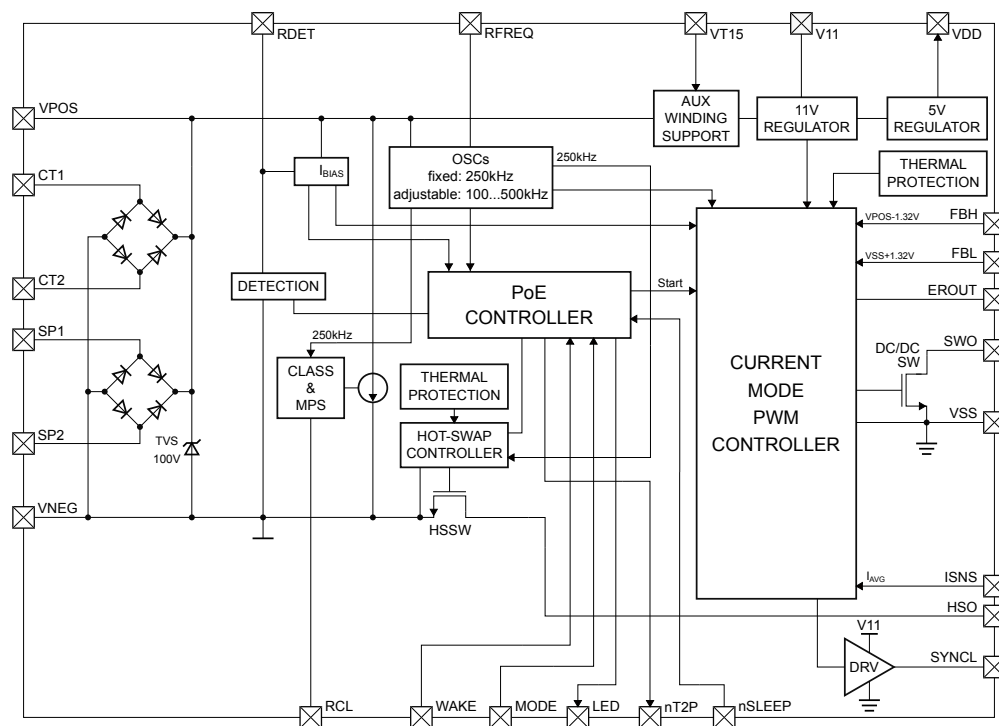

Figure 2.3. Si34062 Block Diagram

2.2 Power over Ethernet (PoE) Line-Side Interface

The PoE line interface consists of diode bridges, internal surge protection, and the protocol interface support for detection and classification.

Internal diode bridge maximum current is given by the specification, I_{RECT} . For Class 1 and Class 2 applications, the internal diode bridge can be used. For Class 3 and Class 4, an external diode bridge needs to be installed.

The external bridge should be connected in parallel to the internal bridge and the designer must ensure that the internal bridge will not conduct significant current by using low-voltage-drop external diodes. For higher efficiency, Schottky diodes are recommended.

Instead of a diode bridge, a Mosfet based bridge can be used as well to further improve the overall efficiency.

The chip features active protection against surge transients and accidentally applied telephony voltages.

2.2.1 Surge Protection

The surge protection circuit is activated if the VPOS-VNEG voltage exceeds V_{PROT} and the hotswap switch is off (dc-dc is not powered). If the hotswap switch is on, the surge power is sunk in the dc-dc input capacitance.

The internal surge protection can be overridden with an external TVS if higher than specified surge conditions need be tolerated. The external surge device must be connected between VPOS and VNEG in parallel to the internal one; therefore, the designer must ensure that the external surge protection will activate prior to the internal surge protection.

2.2.2 Telephony Protection

The Si3406x provides protection against telephony ringing voltage. The telephony ringing is much longer than the surge pulse but it has less energy, therefore, the Si3406x has a switch parallel with the supply (between VPOS and VNEG). When the protection circuit is activated, it turns ON the protection switch; the ringing energy then dissipates on this switch and ringing generator resistance ($> 400 \Omega$).

2.2.3 Detection and Classification

When the Si3406x is connected via Ethernet cable to a PSE-enabled Ethernet switch, it must provide a characteristic resistance (~25 k Ω) to the PSE in a given voltage range (2.7–10.1 V). This is called detection. After the PSE detects the PD, the PSE increases the voltage above the classification threshold 14.5 V. Then, the PD provides the classification current to inform the PSE about its required power class (Class 1, 2, 3, or 4). Type 1 PSEs will recognize the Class 4 PD as Class 0, providing 15.4 W to the PD. Therefore, the optimal Class 4 PD application is designed with two power modes: Low-Power mode (for Type 1 PSE) and High-Power mode (for Type 2 PSE). Type 2 PSEs have additional voltage steps before switching on the PD. After an initial classification voltage pulse, the Type 2 PSE reduces the voltage below the mark threshold level (10 V). At that point, the PD should provide a non-valid detection resistance. Then, the PSE raises a voltage up again to the Class event range (Class 2). Last, before turning ON the dc-dc, the PSE reduces the voltage again (Mark2). This sequence is recognized by the si3406x, and it pulls down its nT2P pin to inform the application about the higher available power; otherwise, the application will need to operate in a reduced power consumption state (Type 1) if the PSE is incapable of delivering Class 4 power.

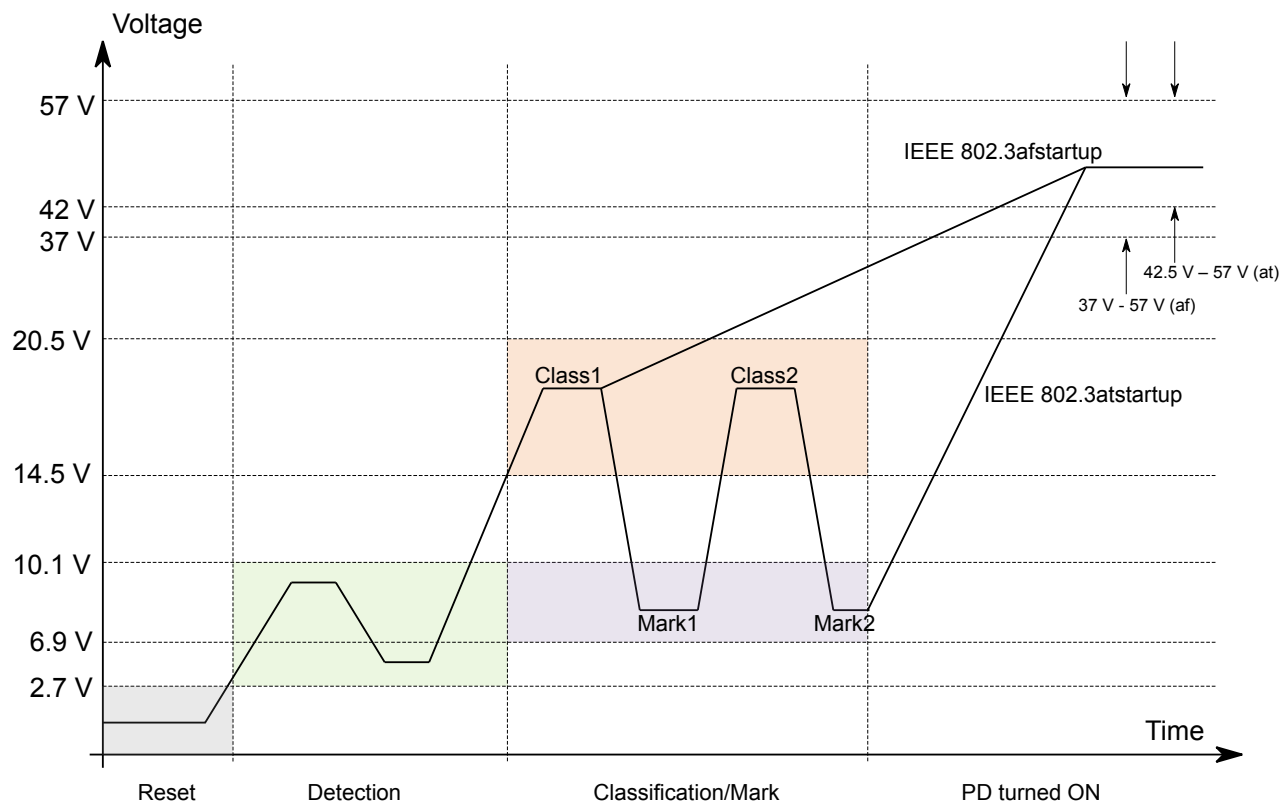

Figure 2.4. Powered Device Voltages

2.3 Hotswap Switch

The hotswap switch is a high-voltage device that separates the PoE interface from the dc-dc converter domain. The internal hotswap switch (HSSW) is turned on (conducting) when the PoE interface voltage goes above V_{UVLO_R} . It provides limited inrush current until the dc-dc side capacitor is charged. The hotswap switch turns off (open) if voltage on the HSSW switch (HSO-VNEG) is greater than V_{HSSW_OFF} .

In overload, the hotswap switch goes into current-limiting mode with a current limit of I_{OVL} . It will turn back ON after $T_{WAITHSSW}$ elapses and the dc-dc input capacitor is recharged, meaning the HSO-VNEG voltage is less than V_{HSSW_ON} .

The hotswap switch (if it is in the on state and conducting) can detect if the current is lower than I_{MPSth} . If automatic sleep mode is enabled, the chip turns on MPS pulse generation, which ensures that the PSE will not disconnect.

With the Si34061, an external hotswap switch can be used to improve efficiency and reduce thermal stress in high current applications. For Class 3 applications, using an external hotswap switch is recommended; for Class 4, it is mandatory because the internal hotswap switch otherwise generates significant heat. When an external hotswap switch is used, intelligent switch control ensures that inrush current limiting and automatic MPS request of the internal switch are still supported.

2.4 HSSW State Machine

The HSSW operates as simple 4-state state machine:

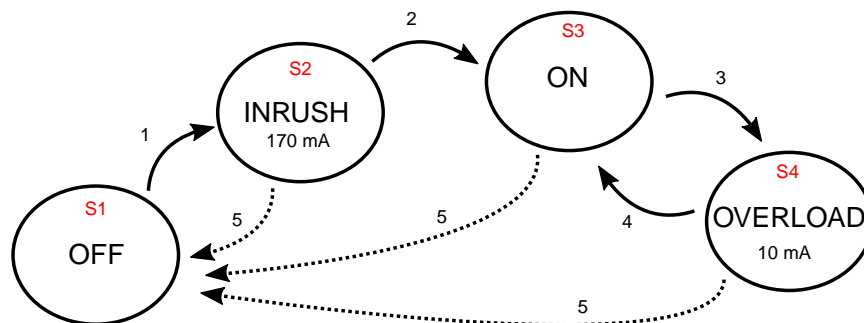

Figure 2.5. Hotswap Switch 4-State Machine

OFF State

HSSW turn-on is controlled by UVLO, the undervoltage lockout feature. When UVLO is engaged, the HSSW is OFF. In this state, the HSSW is in idle mode, VNEG and HSO pins are disconnected. In normal operation, a complete detect/classification procedure precedes the HSSW turn-on, and the control of this sequence is implemented in the state machine logic of the chip.

INRUSH State

After the controller enables the HSSW, the block starts operation in the INRUSH state. In this state the switch itself is not directly turned on, but operating in a closed-loop current limit mode to avoid high current peaks during the charging of the input capacitor of the dc-dc converter.

If the V_{HSSW} voltage drops below 380 mV (meaning the bypass cap is 99% charged), the HSSW will change state to ON either in Type1 classification immediately, or in Type2 classification if the HSSW has been in the INRUSH state for at least 80 ms.

ON State

In ON state, the HSSW switch is completely turned on. The HSSW circuit continuously monitors V_{HSSW} . HSSW will change to OVERLOAD state if V_{HSSW} voltage increases over 3.5 V for at least 140 μ s.

OVERLOAD State

In OVERLOAD state the HSSW operates in closed-loop low current limit mode. If the V_{HSSW} voltage drops below 380 mV again, and the HSSW has been in the OVERLOAD state for at least 80 ms, the HSSW will change back to the ON state.

2.4.1 External HSSW FET Driver

An external HSSW FET may be used to improve thermal operation of an Si34061 at very high power loading levels (the top end of Class 4).

With the Si34061, the chip automatically detects if the EXT_HSW pin is connected to VNEG or to a FET gate at startup. If the external hotswap FET driver will not be used, the EXT_HSW pin must be tied to VNEG.

For further information on using an external HSSW FET, please refer to "AN1130: Using the Si3406/Si34061/Si34062 PoE+ and Si3404 PoE PD Controller In Isolated and Non-Isolated Designs".

2.5.1 Average Current Sensing, Overcurrent, Low-Current Detection, and Output Short Protection

The application average current is sensed by an external resistor (R_{SENSE}) connected between VSS and ISNS. Overcurrent is detected and triggered when the voltage on the sense resistor exceeds $V_{\text{ISNS_OVC}}$. Sizing the resistor allows the designer to set the overcurrent limit according to application needs. When overcurrent is triggered, the dc-dc controller goes into reset until the overcurrent resolves. When the overcurrent is no longer present, the controller starts up again with softstart.

This external sense resistor is also used to detect a low current situation. When the voltage on the sense resistor goes below $V_{\text{ISNS_LC}}$, the dc-dc controller disables the sync FET and the external hotswap switch, allowing very low current consumption—the internal hotswap switch then measures the chip current internally. If the average current is lower than the PoE maintain power signature (MPS) limit, and if automatic sleep mode is enabled (using the NSLEEP pin), the chip turns on the MPS generation. See the sleep mode section for further detail.

The Si3406x integrates output short protection. When the output is shorted, the average input current remains in the normal operating range. If the controller detects a high EROUT signal for more than 1 ms, it resets the dc-dc controller, and a new startup cycle with soft-start turn ON follows.

2.5.2 Sync FET Driver

With the Si3406x family, an optional synchronous rectifying FET may be used in place of an output rectifier diode for improved power conversion efficiency.

A gate driver is provided for this purpose. The synchronous rectifying FET driver is enabled by default in Si3406x configurations, but, if a synchronous FET is not used in the design, the SYNCL pin must not be connected (do not connect SYNCL to any power or ground rail). The synchronous rectifying FET driver is disabled only when the dc-dc converter measures low average current (meaning lower than $V_{\text{ISNS_LC}}$ on ISNS). This ensures low sleep mode current consumption.

2.6 Tunable Oscillator

The dc-dc frequency can be fixed to 250 kHz or tunable by an external resistor.

The tuning resistor must be connected between the R_{FREQ} pin and VPOS. If R_{FREQ} is shorted to VPOS, the fixed frequency oscillator will provide the clock, F_{OSCINT} , to the dc-dc converter; otherwise, the resistor will determine the frequency as shown in the curve below.

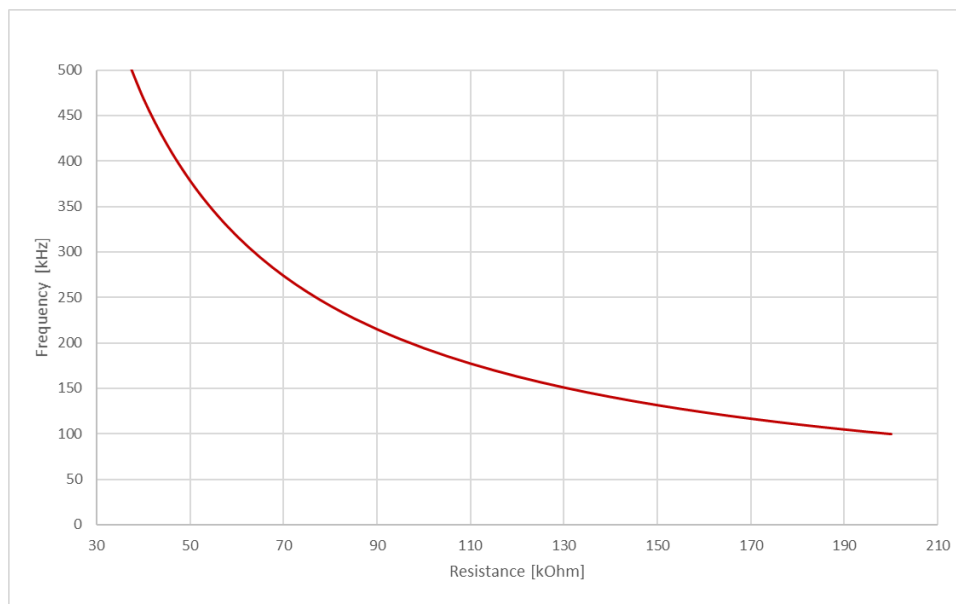

Figure 2.7. R_{FREQ} Frequency Selector Diagram

2.7 Regulators

The chip provides a 5 V output to power LEDs or optocouplers. This is a closed-loop regulator, which ensures accurate output voltage. The 5 V regulator is supplied by an internal 11 V open loop regulator, which also provides power for the external FET gate drivers. The 11 V regulator is supplied by a coarse regulator, which is also open-loop. With the Si34061 and Si34062, the VT15 pin can be used to supply this regulator from an optional auxiliary transformer winding. The advantage of doing so is additional power saving since the external FET drivers' current is not generated from the PoE 50 V but, rather, from a transformer-provided 12–16.5 V. The application must be designed to ensure that the absolute maximum rating voltage for the VT15 pin is not exceeded.

2.8 Sleep Mode

The Si3406 and Si34061 have automatic (consumption-based) and non-automatic sleep modes. When SLEEPb is tied to ground, the automatic sleep mode is enabled, meaning that if the current consumption is lower than I_{MPSth} , the chip will automatically generate MPS pulses from the PSE. If SLEEPb is tied to VDD, then it will not generate MPS pulses, and the PSE will disconnect if total application current consumption drops below 5–10 mA.

For non-automatic sleep mode, tie SLEEPb high at initial startup (right after the hotswap switch turns on). The chip turns OFF automatic mode, but pulling SLEEPb low will force MPS generation as long as the pin is held low. Using this mode, the designer can control MPS generation. For details on MPS generation connection, please refer to "AN1130: Using the Si3406/Si34061/Si34062 PoE+ and Si3404 PoE PD Controller In Isolated and Non-Isolated Designs".

2.9 Special Sleep Mode

In the Si34062, a special sleep mode is available which includes LED, WAKE, and MODE pin support. The LED pin drives a light emitting diode to (for example) illuminate a button on the primary side of the application. The WAKE pin triggers wakeup, and the MODE button controls if MPS generation is enabled in sleep. In the Si34062 case, nSLEEP is used to initiate sleep.

The sleep mode is initiated by a negative transition on nSLEEP. It is latched at that negative transition event together with MODE, so their status is kept until wakeup even if the input changes on these pins due to the secondary side losing power. MPS generation is enabled if MODE = 0 at the nSLEEP transition. The following figure shows the Si34062 sleep mode behavior.

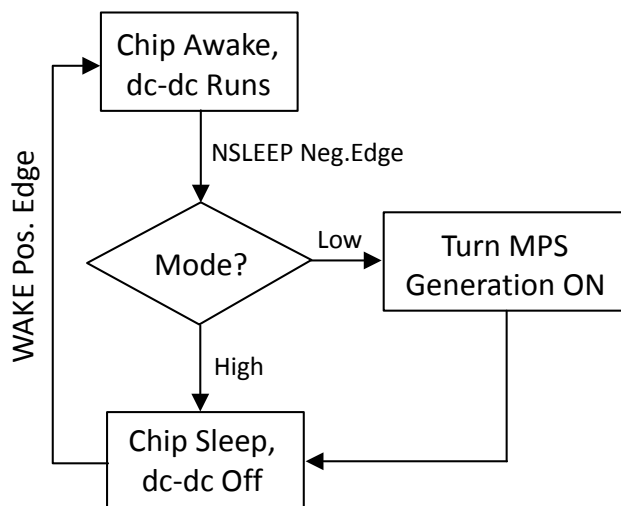

Figure 2.8. Si34062 Special Sleep Mode Behavior

Refer to [Figure 3.3 Si34062 Isolated Flyback Application Diagram on page 13](#), which shows the connectivity for the Si34062 with the special sleep mode.

For details on special sleep mode, please refer to "AN1130: Using the Si3406/Si34061/Si34062 PoE+ and Si3404 PoE PD Controller In Isolated and Non-Isolated Designs".

2.10 External Wall Adapter Support

The Si3406x supports using a wide voltage range of external wall adapters as a primary or secondary supply. The controller is able to provide a stable output voltage with PoE input voltage from the PSE, or with low voltage (12 V) in ASUP mode from the wall adapter. However, if the transformer was designed and optimized for PoE voltages, then the same transformer will not be able to provide high power to the application from a low-voltage adapter (12 V). To ensure operation from both PoE input and wall adapter in the full power range, a high-voltage adapter is recommended.

For details on options and supported modes of adapter connection, please refer to "AN1130: Using the Si3406/Si34061/Si34062 PoE+ and Si3404 PoE PD Controller In Isolated and Non-Isolated Designs".

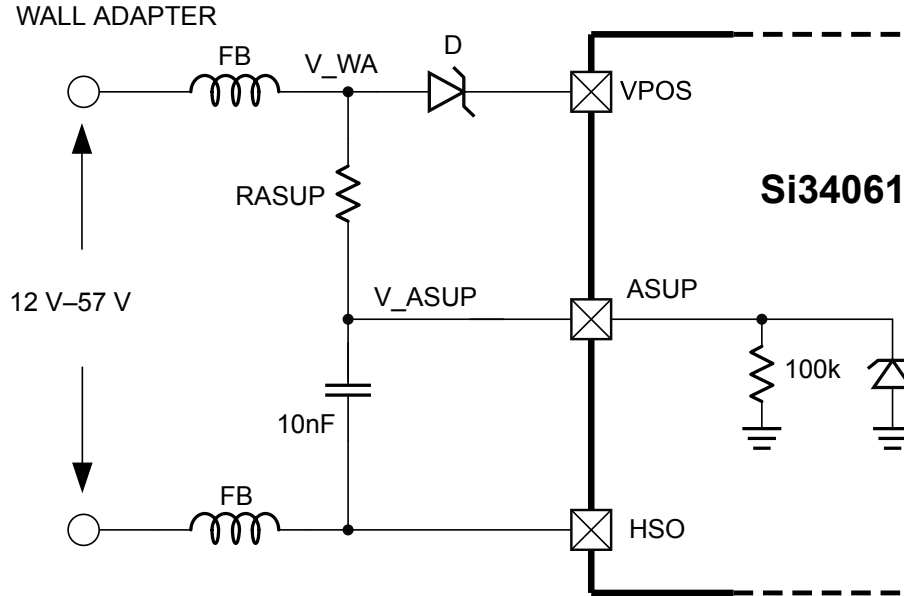

Figure 2.9. Auxiliary Wall Adapter Connection Example

3. Application Examples

The following diagrams demonstrate the ease of use and straightforward BOM of the Si3406x Powered Device ICs. Detailed reference designs are available in Evaluation KIT User Guides. Also refer to "AN1130: Using the Si3406/Si34061/Si34062 PoE+ and Si3404 PoE PD Controller In Isolated and Non-Isolated Designs".

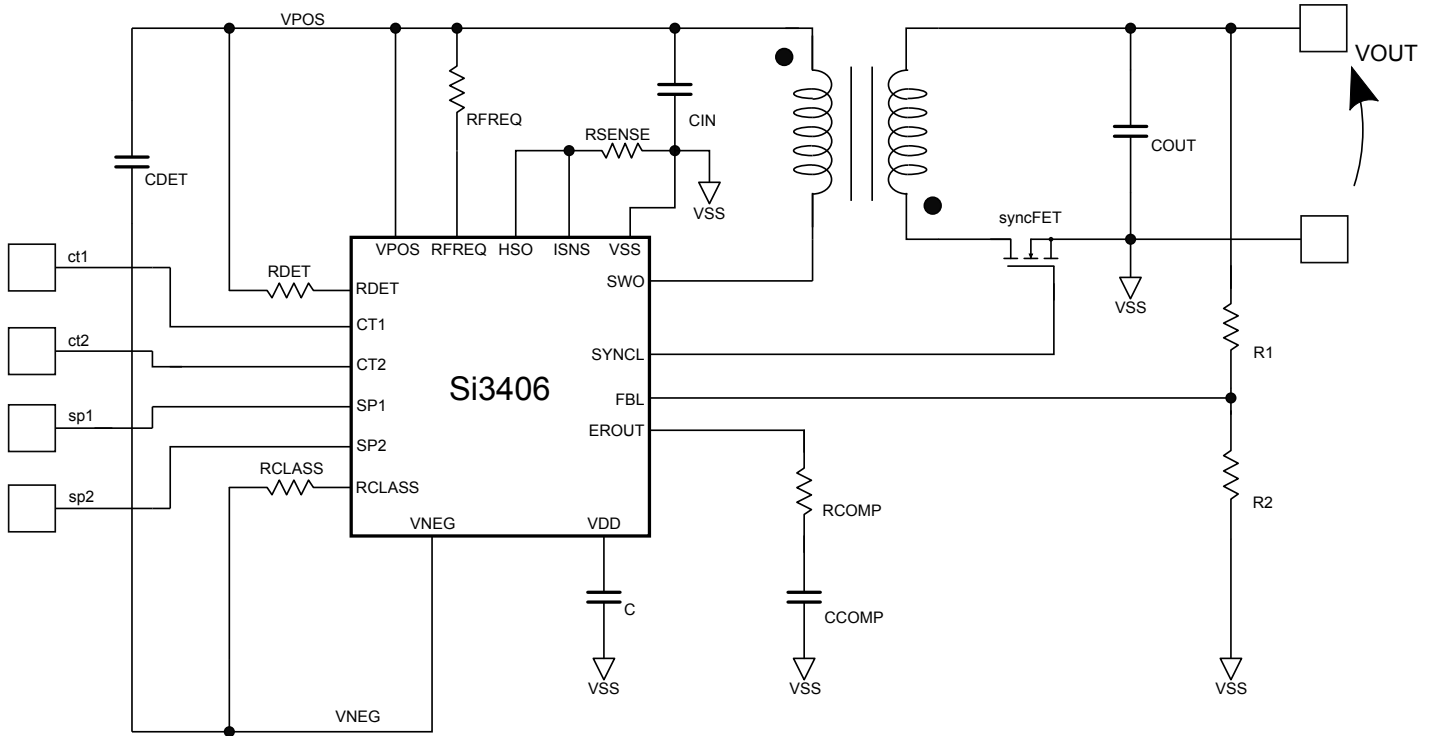

Figure 3.1. Si3406 Non-Isolated Flyback Application Diagram

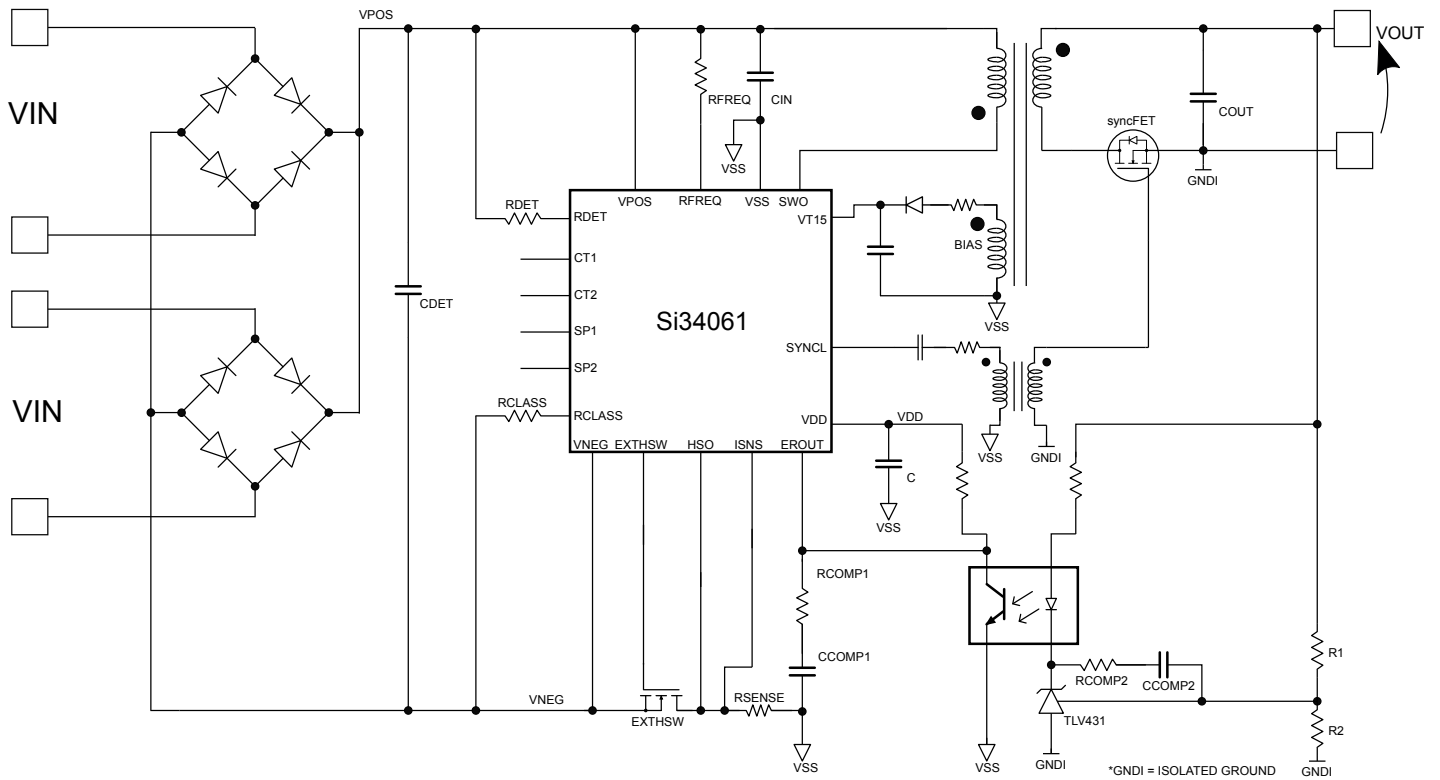

Figure 3.2. Si34061 Isolated Flyback Application Diagram

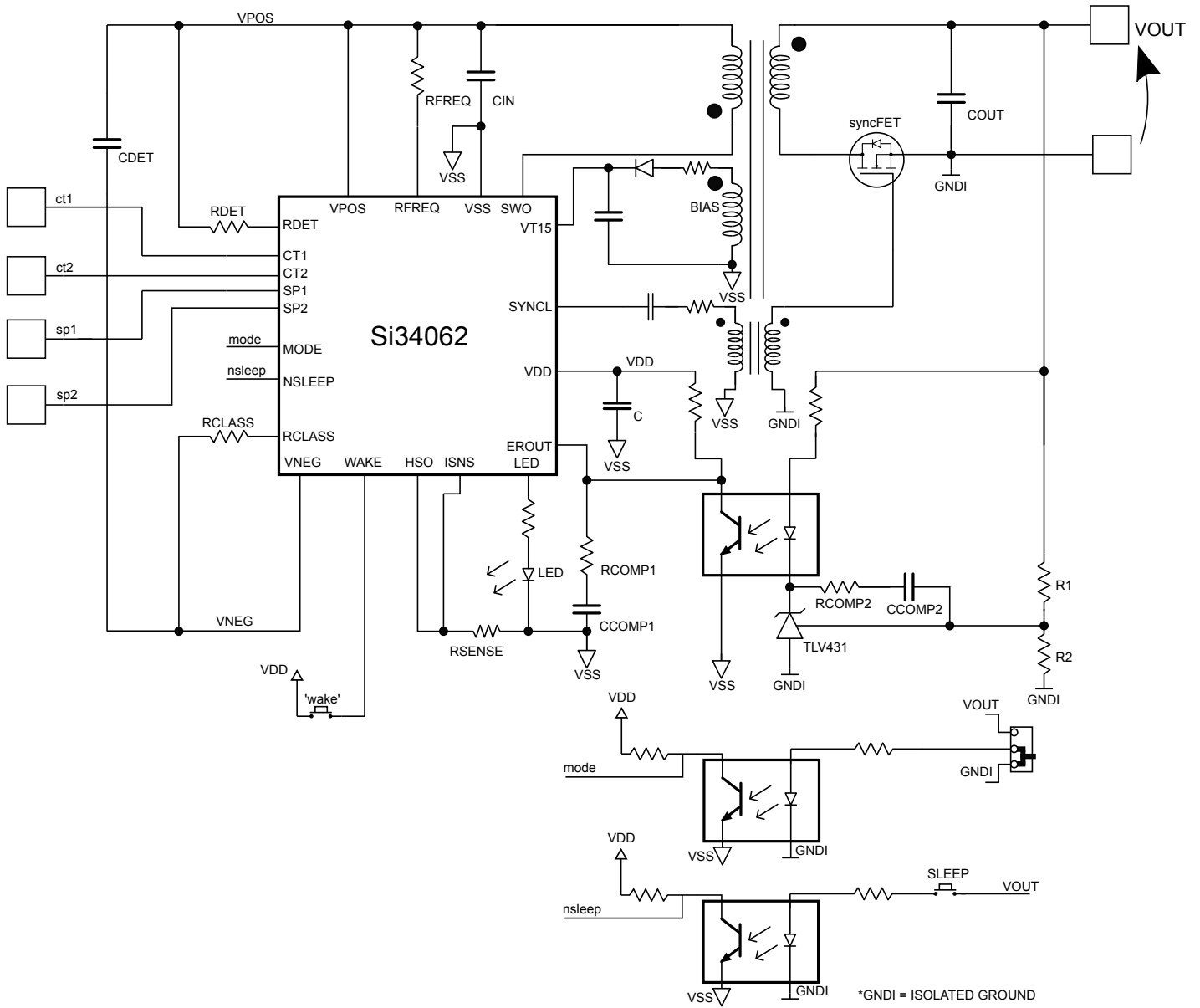

Figure 3.3. Si34062 Isolated Flyback Application Diagram

4. Electrical Specifications

Table 4.1. Absolute Maximum Ratings¹

| Type | Description | Min | Max | Units |
|-------------------------|--------------------------------------------------------------------------------------------------------------------------------------|------|-----|-------|
| Voltage | CT1–CT2 or SP1–SP2 | –100 | 100 | V |
| | VNEG-VSS, VPOS-VNEG, HSO ² , RDET ³ | –0.7 | 100 | V |
| | SWO-VSS | –0.7 | 120 | V |
| | ISNS, SWISNS | –1 | 1 | V |
| | Low Voltage pins: FBH ³ , EROUT, FBL, NSLEEP, RCL ² , RFREQ ³ , ASUP ³ , WAKE, MODE, LED | –0.7 | 6 | V |
| | Mid Voltage pins: SYNCL, VT15, EXTGD, EXTHSW | –0.7 | 18 | V |
| | Other Mid Voltage pin: V11 | –0.7 | 12 | V |
| Peak Current | CT1, CT2, SP1, SP2, VPOS ⁴ | –5 | 5 | A |
| DC Current ⁵ | CT1, CT2, SP1, SP2 | –0.2 | 0.2 | A |
| Temperature | Storage Temperature | –65 | 150 | °C |
| | Ambient Operating Temperature | –40 | 85 | °C |
| | Junction Temperature | — | 150 | °C |

Note:

1. Unless otherwise noted, all voltages referenced to VSS. Permanent device damage may occur if the maximum ratings are exceeded. Functional operation should be restricted to those conditions specified in the operational sections of this data sheet. Exposure to absolute maximum rating conditions for extended periods may adversely affect device reliability.
2. Voltage referenced to VNEG.
3. Voltage referenced to VPOS.
4. The Si340x provides internal protection from certain transient surge voltages on these pins. Refer to [AN1130: Si3404/06x PoE-PD Controller Design Guide](#) for further details.
5. Higher dc current is possible in the application, but only utilizing external bridge diodes. Refer to reference design documentation and [AN1130: Si3404/06x PoE-PD Controller Design Guide](#) for further details.

Table 4.2. Recommended Operating Conditions

| Symbol | Parameter (Condition) | Min | Typ | Max | Unit |
|----------------------|--------------------------------------------------------------------------------------------------------------|------|------|------|------|
| V _{PORT} | CT1 – CT2 or SP1 – SP2 | 2.7 | — | 57 | V |
| V _{HV_OP} | VNEG-VSS, VNEG-HSO, VPOS-VSS, VPOS-VNEG | 1.5 | — | 57 | V |
| V _{LV_OP} | VPOS referred low voltage pins: RFREQ, RDET, FBH | –5.5 | — | 0 | V |
| V _{LV_OP} | VSS referred low voltage pins: VDD, FBL, EROUT, ASUP, nSLEEP, nT2P, ASUP, WAKE, MODE, LED ¹ | 0 | — | 5.5 | V |
| V _{ISNS_OP} | VSS referred current sensing pins: ISNS, SWISNS | –0.5 | — | 0.5 | V |
| V _{LV_OP} | VNEG referred low voltage pins: RCL | 0 | — | 5.5 | V |
| V _{MV_OP} | VSS referred medium voltage pins SYNCL, EXTGD, EXTBSW | 0 | — | 13 | V |
| V _{MV_VT15} | VSS referred medium voltage pin VT15 ² | 12 | 14.5 | 16.5 | V |
| I _{RECT} | On chip rectifier current on CT1, CT2, SP1, SP2—steady state ³ | — | — | 176 | mA |
| V _{RECT} | On chip rectifier voltage @ 200 mA, 2 diodes | — | 1.8 | — | V |
| I _{RECT_PK} | Peak rectifier current Max 75 ms 5% Duty Cycle ⁴ | — | — | 231 | mA |
| I _{AVG} | Allowable continuous current on SWO, VSS, HSO, VNEG | — | — | 600 | mA |
| I _{MAX} | Maximum current on HSO, VNEG, VPOS Max 75 ms 5% Duty Cycle | — | — | 683 | mA |

Note:

- For all digital inputs (MODE, NSLEEP, WAKE, ASUP) Voh low to high transition voltage max is 3.7 V; Vol high to low voltage min is 1.6 V.
- V_{MV_VT15} is relevant for Si34061 and Si34062 only when an external auxiliary winding from the primary side of the transformer is being used to improve power conversion efficiency. This can be left undriven, in which case an internal regulator will be used.
- For Class 3 and above operation, use external diode bridge rectifiers to bypass the internal input diode bridge rectifiers.
- The IEEE 802.3at specification allows for higher peak current for transients.

Table 4.3. Electrical Characteristics

Excluding detection and classification and unless otherwise noted, $37\text{ V} < V_{\text{POS}} - V_{\text{NEG}} \leq 57\text{ V}$; junction temperature = -40 to $+125$ °C; typical specs are measured at 25 °C. All voltages are with respect to VSS unless otherwise noted.

| Symbol | Parameter (Condition) | Min | Typ | Max | Unit |
|---------------------------------------------------------|-------------------------------------------------------------------------|-------|-----|-------|------------|
| PoE PROTOCOL | | | | | |
| Detection | | | | | |
| V_{DET} | Signature Range (at V_{PORT}) | 2.7 | — | 10.1 | V |
| | Signature Resistance (at V_{PORT}) | 23.75 | — | 26.25 | k Ω |
| Classification | | | | | |
| V_{RESET} | Classification Reset (at V_{PORT}) | 0 | — | 2.81 | V |
| V_{CLASS} | Classification ON threshold (at V_{PORT}) | — | — | 14.5 | V |
| | Classification OFF threshold (at V_{PORT}) | 20.5 | — | — | V |
| $I_{\text{PortCLASS}}$ | Class 0 ($R_{\text{CLASS}} > 681\ \Omega$) | 0 | — | 4 | mA |
| | Class 1 ($R_{\text{CLASS}} = 140\ \Omega @ 1\%$) | 9 | — | 12 | mA |
| | Class 2 ($R_{\text{CLASS}} = 75\ \Omega @ 1\%$) | 17 | — | 20 | mA |
| | Class 3 ($R_{\text{CLASS}} = 48.7\ \Omega @ 1\%$) | 26 | — | 30 | mA |
| | Class 4 ($R_{\text{CLASS}} = 33.2\ \Omega @ 1\%$) | 36 | — | 44 | mA |
| Type 2 Classification | | | | | |
| V_{MARK} | Mark event voltage (at V_{PORT}) | 6.9 | — | 10.1 | V |
| I_{MARK} | Mark event current | 0.25 | — | 4 | mA |
| Power On and UVLO | | | | | |
| $V_{\text{UVLO_R}}$ | Hotswap closed and converter on | 34 | 37 | 40 | V |
| $V_{\text{UVLO_F}}$ | Hotswap open and converter off | 30 | 32 | 34 | V |
| $V_{\text{UVLO_HYST}}$ | | 3.5 | 4.5 | 6 | V |
| Thermal Characteristics | | | | | |
| T_{SHD} | Thermal shutdown | — | 160 | — | °C |
| T_{HYST} | Thermal shutdown hysteresis | — | 20 | — | °C |
| On-Chip Transient Voltage Suppression/Protection | | | | | |
| V_{PROT} | TVS protection activation voltage ($V_{\text{POS}} - V_{\text{NEG}}$) | 100 | — | — | V |
| Hotswap Switch | | | | | |
| I_{inrush} | Inrush current | 100 | 170 | 200 | mA |
| I_{MAXHSSW} | Maximum continuous operating current | — | — | 600 | mA |
| $V_{\text{HSSW_ON}}$ | Switch ON voltage | — | 380 | — | mV |
| $V_{\text{HSSW_OFF}}$ | Switch OFF voltage, HSSW goes to overload cycle | — | 3.5 | — | V |

| Symbol | Parameter (Condition) | Min | Typ | Max | Unit |
|-------------------|------------------------------------------------------------------------|-------|------|-------|----------|
| I_{OVL} | Switch current limit in OVERLOAD State | — | 10.5 | — | mA |
| I_{MPStH} | MPS signal request current level threshold | 14 | 20 | 26 | mA |
| I_{EXT_DRV} | External hotswap driver peak current on EXTHSW pin | — | — | 10 | mA |
| V_{EXT_DRV} | External hotswap driver voltage on EXTHSW pin | 9 | 11 | 13 | V |
| $T_{WAITHSSW}$ | Wait time in OVERLOAD and type 2 inrush | 80 | 96 | 116 | ms |
| R_{ONHSSW} | Internal hotswap drain-source resistance while ON | 0.65 | 1.5 | 2.9 | Ω |
| DC-DC | | | | | |
| $I_{SWOPEAK}$ | Peak current limit of internal FET (SWO pin) | 2.1 | — | 2.7 | A |
| V_{EXTGD} | External FET driver voltage (EXTGD pin) | 9 | 11 | 13 | V |
| I_{EXTGD} | External FET driver peak current (EXTGD pin) | — | — | 500 | mA |
| F_{OSCINT} | Using internal Oscillator | 215 | 250 | 290 | kHz |
| F_{OSCEXT} | Using external Oscillator, RFREQ = 215 k Ω | 75 | 95 | 115 | kHz |
| | Using external Oscillator, RFREQ = 39 k Ω | 420 | 470 | 520 | kHz |
| DUC | Output duty cycle of PWM | — | — | 75 | % |
| $V_{DCDCUVLO}$ | DCDC UVLO level (Minimum adapter voltage-ASUP mode) | 10.75 | 11.3 | 11.85 | V |
| V_{FBREF} | FBH (referenced to VPOS) and FBL (referenced to VSS) reference voltage | 1.28 | 1.32 | 1.36 | V |
| V_{EROUT} | Operating voltage range of error input | 1 | — | 4 | V |
| T_{HICCUP} | Output short protection if EROUT is max | — | 1 | — | ms |
| V_{ISNS_OVC} | Overcurrent limit voltage on ISNS (ref. to VSS) | -305 | -270 | -255 | mV |
| V_{ISNS_LC} | Low current limit voltage on ISNS (ref. to VSS) | -45 | -30 | -15 | mV |
| $V_{SWISNSMAX}$ | External FET peak current sense | — | 240 | — | mV |
| $T_{SOFTSTART}$ | Startup time ¹ | — | 15 | — | ms |
| R_{ONDCDC} | Internal DCDC switching FET drain-source resistance while ON | — | 0.9 | 1.2 | Ω |
| Regulators | | | | | |
| V_{T15} | Override internal regulator with transformer winding | 12.5 | — | 16.5 | V |
| V_{DD} | 5 V regulated output | 4.9 | 5.2 | 5.5 | V |
| V_{DDILIM} | DC current limit of VDD | 9.7 | 11.2 | — | mA |
| C_{REG} | Filter capacitor on VDD and V11 | 82 | 100 | 220 | nF |
| I_{MAXLED} | LED pin max current, reduces V_{DDILIM} | — | 5 | — | mA |
| I_{MAXDO} | Digital output max current (NT2P), reduces V_{DDILIM} | 2 | 2.5 | — | mA |

| Symbol | Parameter (Condition) | Min | Typ | Max | Unit |
|----------------------------------------------------|-----------------------------------------------|-----|------|-----|------|
| Power Dissipation² | | | | | |
| P_{INTMAX} | DC-DC max power internal FET | — | 0.2 | 0.9 | W |
| P_{MAX} | Total chip power | — | 0.5 | — | W |
| I_{PortOP} | Operating current (V_{PORT} 57 V; 250 kHz) | — | 3 | 5 | mA |
| Package Thermal Characteristics² | | | | | |
| θ_{JA} | QFN20 | — | 44 | — | C°/W |
| θ_{JA} | QFN24 | — | 38.5 | — | C°/W |
| Note: | | | | | |
| 1. Depends on output load. | | | | | |
| 2. Assumes 4-Layer PCB with adequate layout. | | | | | |

5. Pin Descriptions

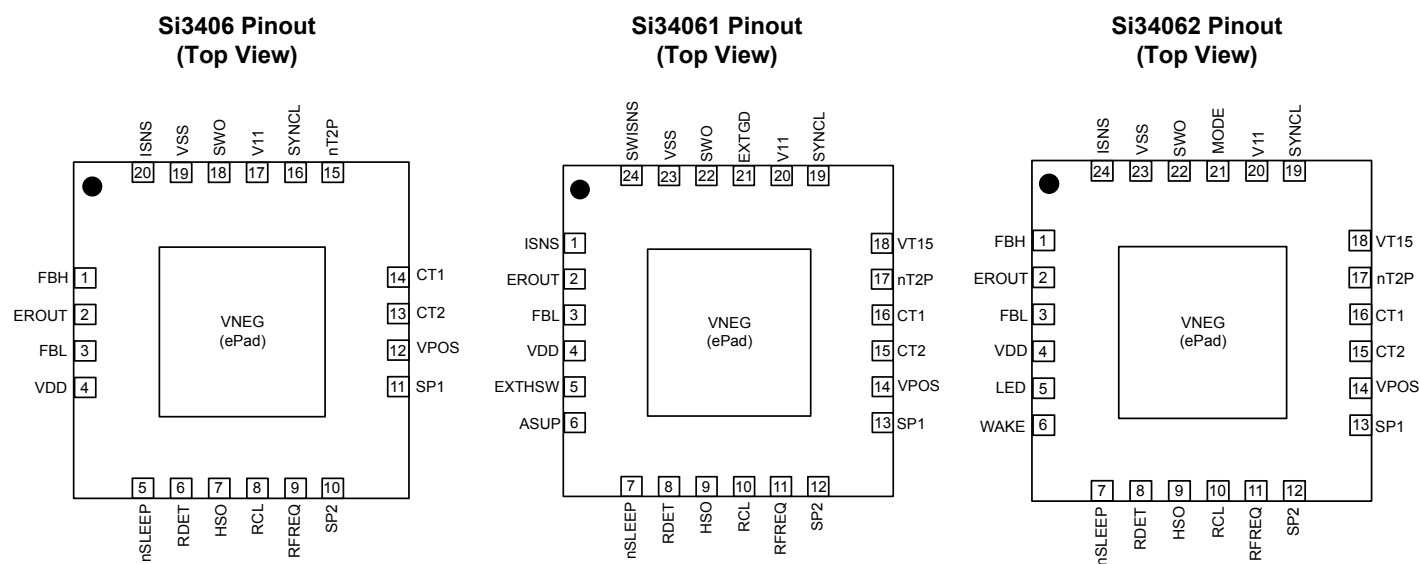

Table 5.1. Pin Descriptions

| '06 Pins | '061 Pins | '062 Pins | Name | Ref | Dir. | Vrange | Description |
|----------|-----------|-----------|---------|------|------|---------|-------------------------------------------------------------------------------|
| | 24 | 24 | SWISNS | VSS | I | 0–1 | External FET peak current sense resistor voltage input |
| 20 | 1 | | ISNS | VSS | I | -1–0 | Chip average current sense resistor input |
| 1 | | 1 | FBH | VPOS | I | 0–5.5 | High side (VPOS referred) dc-dc feedback (Buck converter) |
| 2 | 2 | 2 | EROUT | VSS | IO | 0–5.5 | Error amplifier current output, compensation impedance input |
| 3 | 3 | 3 | FBL | VSS | I | 0–5.5 | Low side (VSS referenced) dc-dc feedback (Flyback converter) |
| 4 | 4 | 4 | VDD | VSS | O | 0–5.5 | 5 V regulator output |
| | | 5 | LED | VSS | O | 0–5.5 | Output to drive sleep LED |
| | 5 | | EXTTHSW | VNEG | O | 0–11 | External hotswap switch drive |
| | | 6 | WAKE | VSS | I | 0–5.5 | Wakeup from sleep mode |
| | 6 | | ASUP | VSS | I | 0–5.5 | AUX auxiliary adapter present |
| 5 | 7 | 7 | nSLEEP | VSS | I | 0–5.5 | Sleep, with pull-up, driven by open drain |
| 6 | 8 | 8 | RDET | VPOS | IO | 0–100 | Detection resistor |
| 7 | 9 | 9 | HSO | VNEG | IO | 0–100 | Hotswap switch output |
| 8 | 10 | 10 | RCL | VNEG | IO | 0–5.5 | Classification resistor |
| 9 | 11 | 11 | RFREQ | VPOS | IO | 0–5.5 | Oscillator frequency tuning resistor, tie to VPOS to select default frequency |
| 10 | 12 | 12 | SP2 | SP1 | I | 0 - 100 | High-voltage supply input from spare pair; polarity-insensitive |
| 11 | 13 | 13 | SP1 | SP2 | I | 0–100 | High-voltage supply input from spare pair; polarity-insensitive |
| 12 | 14 | 14 | VPOS | — | IO | 0–100 | Rectified high-voltage supply positive rail |
| 13 | 15 | 15 | CT2 | CT1 | I | 0–100 | High-voltage supply input from main pair; polarity-insensitive |
| 14 | 16 | 16 | CT1 | CT2 | I | 0 - 100 | High-voltage supply input from main pair; polarity-insensitive |

| '06 Pins | '061 Pins | '062 Pins | Name | Ref | Dir. | Vrange | Description |
|----------|-----------|-----------|-------|-----|------|--------|--------------------------------------------------------------------------------|
| 15 | 17 | 17 | nT2P | VSS | O | 0–5.5 | Type II classification was successful |
| | 18 | 18 | VT15 | VSS | I | 0–16.5 | dc-dc transformer bias winding input |
| 16 | 19 | 19 | SYNCL | VSS | O | 0–11 | Gate driver for synchronous rectification FET |
| 17 | 20 | 20 | V11 | VSS | IO | 0–11 | 11 V regulator output for filter cap. |
| | 21 | | EXTGD | VSS | O | 0–11 | External FET gate drive. When internal switching FET is in use, tie to VSS. |
| | | 21 | MODE | VSS | I | 0–5.5 | Controls MPS and LED switch behavior |
| 18 | 22 | 22 | SWO | VSS | O | 0–120 | Internal dc-dc switch output (NMOS drain) |
| 19 | 23 | 23 | VSS | — | IO | 0 | dc-dc converter primary ground |
| ePad | ePad | ePad | VNEG | — | IO | 0 | Rectified high voltage supply ground |

5.1 Detailed Pin Descriptions

Table 5.2. Circuit Equivalent and Description of Die Pads

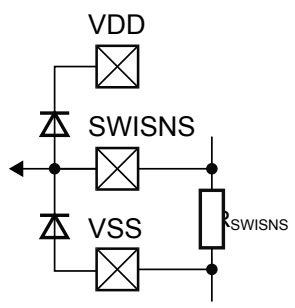
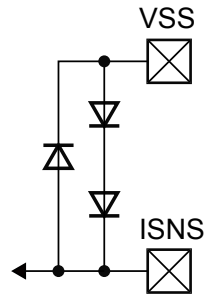
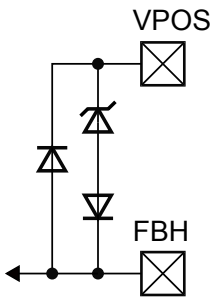
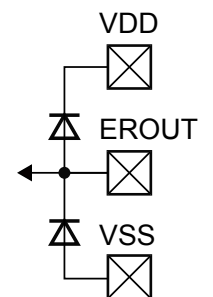
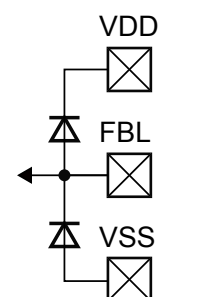
| Pin Name | Detailed Description | Circuit Detail |
|----------|----------------------------------------------------------------------------------------------------------------------------------------------------------------------------------------------------------------------------------|---------------------------------------------------------------------------------------|
| SWISNS | External dc-dc switching FET peak current sense resistor input. The maximum current of the switching FET should correspond to voltage $V_{SWISNS-SMAX}$. |  |
| ISNS | Average current sense resistor input. The resistor value will set the maximum allowed average current for the application. The overcurrent threshold voltage V_{ISNS_OVC} . Note that this pin voltage goes below VSS. |  |
| FBH | High side dc-dc feedback input. Need to be tied to VPOS when not used. See VFBREF. |  |
| EROUT | dc-dc converter error output; current out, voltage sense. Loop compensating impedance should be connected here. $I_{EROUT} = (V_{FBH} - V_{FBREF}) \times 50 \mu A$ or $I_{EROUT} = (V_{FBL} - V_{FBREF}) \times 50 \mu A$ |  |
| FBL | Low side dc-dc feedback input. Need to be tied to VSS when not used. See VFBREF |  |

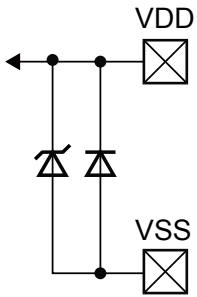
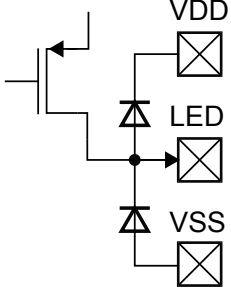
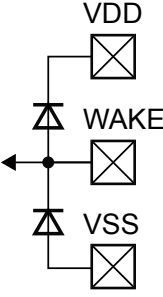
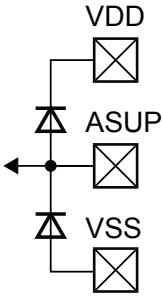
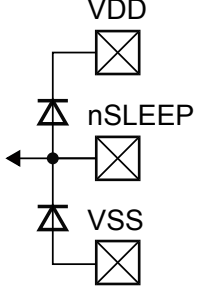
| Pin Name | Detailed Description | Circuit Detail |
|----------|-----------------------------------------------------------------------------------------------------------------------------------------------------------------------------------------------------------------|---------------------------------------------------------------------------------------|
| VDD | <p>Regulated 5 V relative to VSS. There is no foldback characteristic, reaching VDD_{ILIM} the output voltage decreases.</p> <p>The regulator needs C_{REG} external capacitance.</p> |  |
| LED | <p>LED driver output Max current is I_{MAXLED}</p> |  |
| WAKE | <p>Wake-up input pin for sleep mode, used only in Si34062.</p> |  |
| ASUP | <p>Auxiliary supply adapter is present. Enables the operation of the dc-dc controller without PoE supply being present (used only in Si34061).</p> |  |
| nSLEEP | <p>Sleep function input, see description in Sleep mode section.</p> |  |

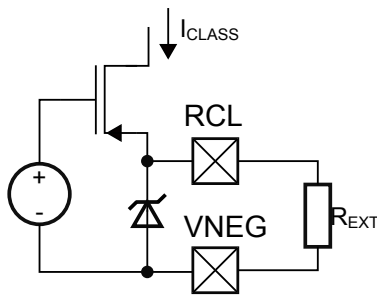
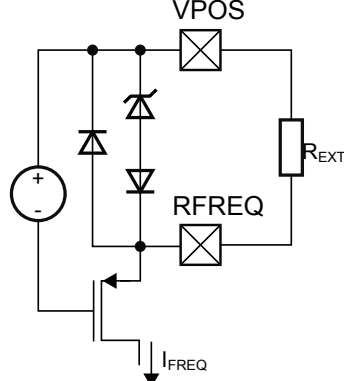
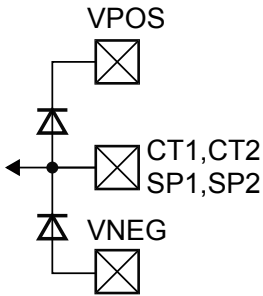
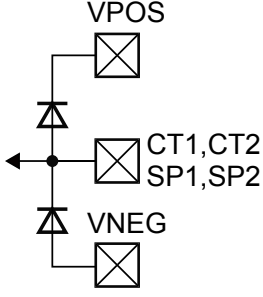
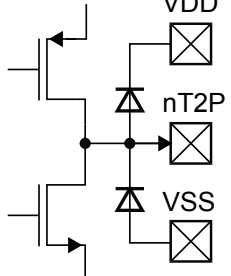
| Pin Name | Detailed Description | Circuit Detail |
|----------------------|----------------------------------------------------------------------------------------------------------------------------------------------------------------------------------------------------------------------------------------------------------------------------------------|---------------------------------------------------------------------------------------|
| RCL | Classification resistor input. For class 0 this pin can be left floating. Pin is active only at time of classification. |  |
| RFREQ | Used for adjusting the oscillator frequency. The frequency is inversely proportional to the value of the connected resistor. |  |
| SP1, SP2 CT1, CT2 | Main power inputs, goes to diode bridge producing VPOS and VNEG. Can be used up to Class 1 and Class 2. For higher power classes, external bridge is required. |  |
| VPOS, VNEG | Main chip power output generated by the diode bridge. Note that VNEG (the ePad on the bottom of the chip) also provides thermal relief. |  |
| nT2P | Pin main function is digital output; it is low if Type 2 classification was successful and the application is allowed to draw class 4 current. Output current is I_{MAXDO} , but the load (e.g. an LED) should be connected to VDD not VSS; otherwise, it can cause false operation. |  |

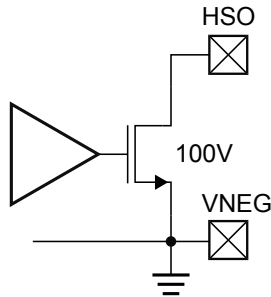
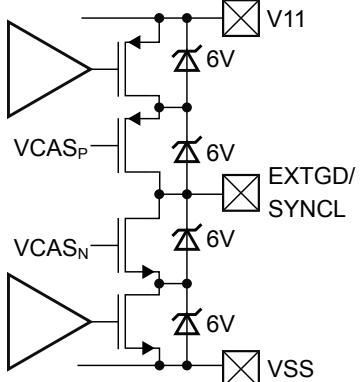
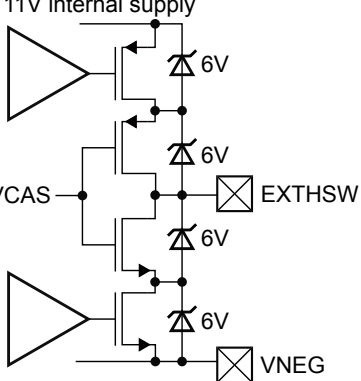
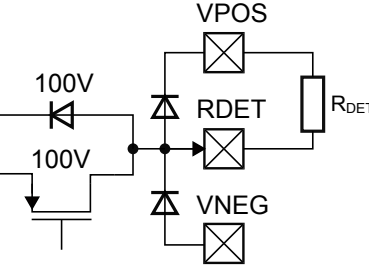
| Pin Name | Detailed Description | Circuit Detail |
|--------------|------------------------------------------------------------------------------------------------------------------------------------------------------------------------------------------------------------------------------------------------------------------------------------------------------------------------------------------------------------------------------------------------------------------------------------------------------|---------------------------------------------------------------------------------------|
| HSO | Hotswap Switch Output. The switch shorts the VNEG and HSO pins, and includes several other functions. See hotswap switch section for details. |  |
| EXTGD, SYNCL | <p>EXTGD: Optional external switch driver of the dc-dc converter. When the internal switch is used this pin should be tied to VSS. This driver controls the external switch with 10 V logic level, relative to VSS.</p> <p>SYNCL: Optional synchronous rectifier switch driver of the dc-dc converter. When not used the pin must be left floating. This driver controls the external synchronous switch with 10 V logic level, relative to VSS.</p> |  |
| EXTHSW | Optional external hotswap switch driver output. The maximum current of the internal hotswap switch is $I_{MAXHSSW}$, for higher currents an external NMOS FET should be used in parallel with the internal HSSW (VNEG-HSO). When EXTGD is not used the pin should be tied to VNEG. This driver controls the external switch with 10 V logic level, relative to VNEG. |  |
| RDET | The user has to tie the RDET resistor between this pin and VPOS. During detection, a high voltage switch pulls down RDET to VNEG. After detection, the reference block uses RDET as absolute chip current reference, forcing -750 mV relative to VPOS, creating 30 μ A for the internal blocks. |  |

| Pin Name | Detailed Description | Circuit Detail |
|-----------|---------------------------------------------------------------------------------------------------------------------------------------------------------------------------------------------------------------------------------------------------------------------------------------------------------------------------------------------------------------------------|----------------|
| VT15, V11 | <p>VT15 is input for an optional 15 V supply generated by an auxiliary transformer bias winding. If the bias winding voltage is lower than VT15_MIN, the internal 15 V coarse regulator will provide the current for the 11 V regulator.</p> <p>The V11 pin is for filtering capacitor for the 11 V regulator. A capacitor of value C_{REG} is required.</p> | |
| MODE | MPS mode control, used in Si34062. | |
| SWO | dc-dc converter switching transistor drain output, $V_{max} = 120\text{ V}$. | |
| VSS | dc-dc converter ground. | |

6. Packaging

6.1 Package Outline: Si3406

The figure below illustrates the package details for the Si3406. The table lists the values for the dimensions shown in the illustration.

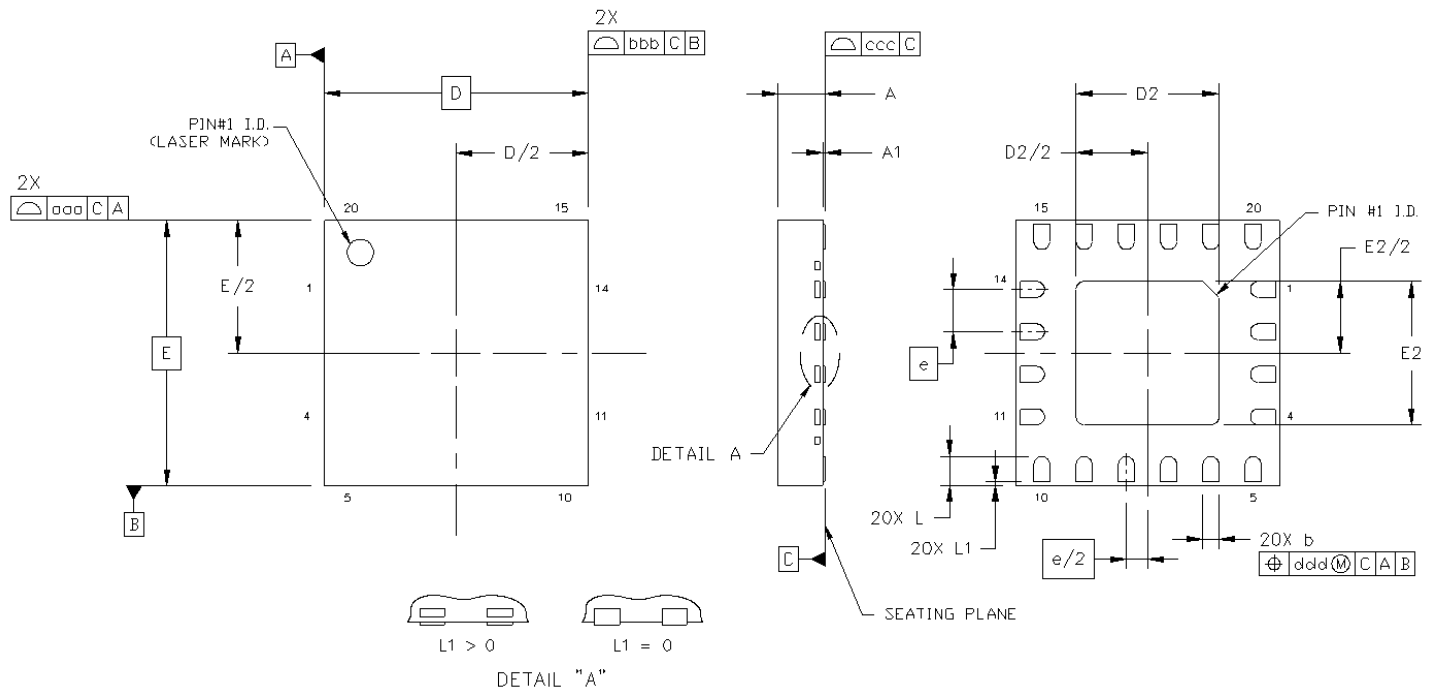

Figure 6.1. 20-Pin, QFN Package

Table 6.1. Package Diagram Dimensions

| Dimension | Min | Nom | Max |
|-----------|-----------|------|------|
| A | 0.80 | 0.85 | 0.90 |
| A1 | 0.00 | 0.02 | 0.05 |
| b | 0.25 | 0.30 | 0.35 |
| D | 5.00 BSC. | | |
| D2 | 2.60 | 2.70 | 2.80 |
| e | 0.80 BSC. | | |
| E | 5.00 BSC. | | |
| E2 | 2.60 | 2.70 | 2.80 |
| L | 0.50 | 0.55 | 0.60 |
| L1 | 0.00 | — | 0.10 |
| aaa | — | — | 0.10 |
| bbb | — | — | 0.10 |
| ccc | — | — | 0.08 |
| ddd | — | — | 0.10 |

| Dimension | Min | Nom | Max |
|-------------------------------------------------------------------------------------------------------------------------------------------------------------------------------------------------------------------------------------------------------------------------------------------------------|-----|-----|-----|
| <p>Note:</p> <ol style="list-style-type: none">1. All dimensions shown are in millimeters (mm) unless otherwise noted.2. Dimensioning and Tolerancing per ANSI Y14.5M-1994.3. This drawing conforms to the JEDEC Solid State Outline MO-220, Variation VHHB-1. | | | |

6.2 Land Pattern: Si3406

The figure below illustrates the land pattern details for the Si3406. The table lists the values for the dimensions shown in the illustration.

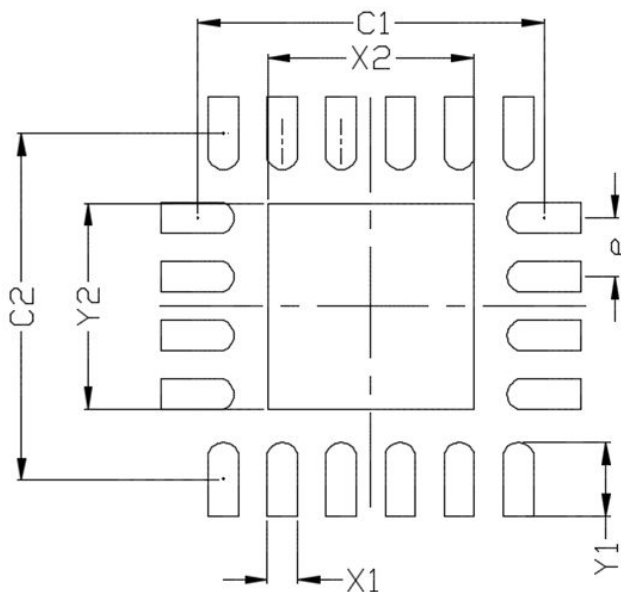

Figure 6.2. 20-Pin, QFN Land Pattern

Table 6.2. Land Pattern Dimensions

| Dimension | Max |
|-----------|------|
| C1 | 4.70 |
| C2 | 4.70 |
| X1 | 0.35 |
| X2 | 2.80 |
| Y1 | 1.00 |
| Y2 | 2.80 |
| e | 0.80 |

Note:

General

1. All dimensions shown are in millimeters (mm) unless otherwise noted.
2. This land pattern design is based on the IPC-7351 guidelines.

Solder Mask Design

1. All metal pads are to be non-solder mask defined (NSMD). Clearance between the solder mask and the metal pad is to be 60 μm minimum, all the way around the pad.

Stencil Design

1. A stainless steel, laser-cut and electro-polished stencil with trapezoidal walls should be used to assure good solder paste release.
2. The stencil thickness should be 0.125 mm (5 mils).
3. The ratio of stencil aperture to land pad size should be 1:1 for all perimeter pads.

Card Assembly

1. A No-Clean, Type-3 solder paste is recommended.
2. The recommended card reflow profile is per the JEDEC/IPC J-STD-020 specification for Small Body Components.

6.3 Package Outline: Si34061/62

The figure below illustrates the package details for the Si34061/62. The table lists the values for the dimensions shown in the illustration.

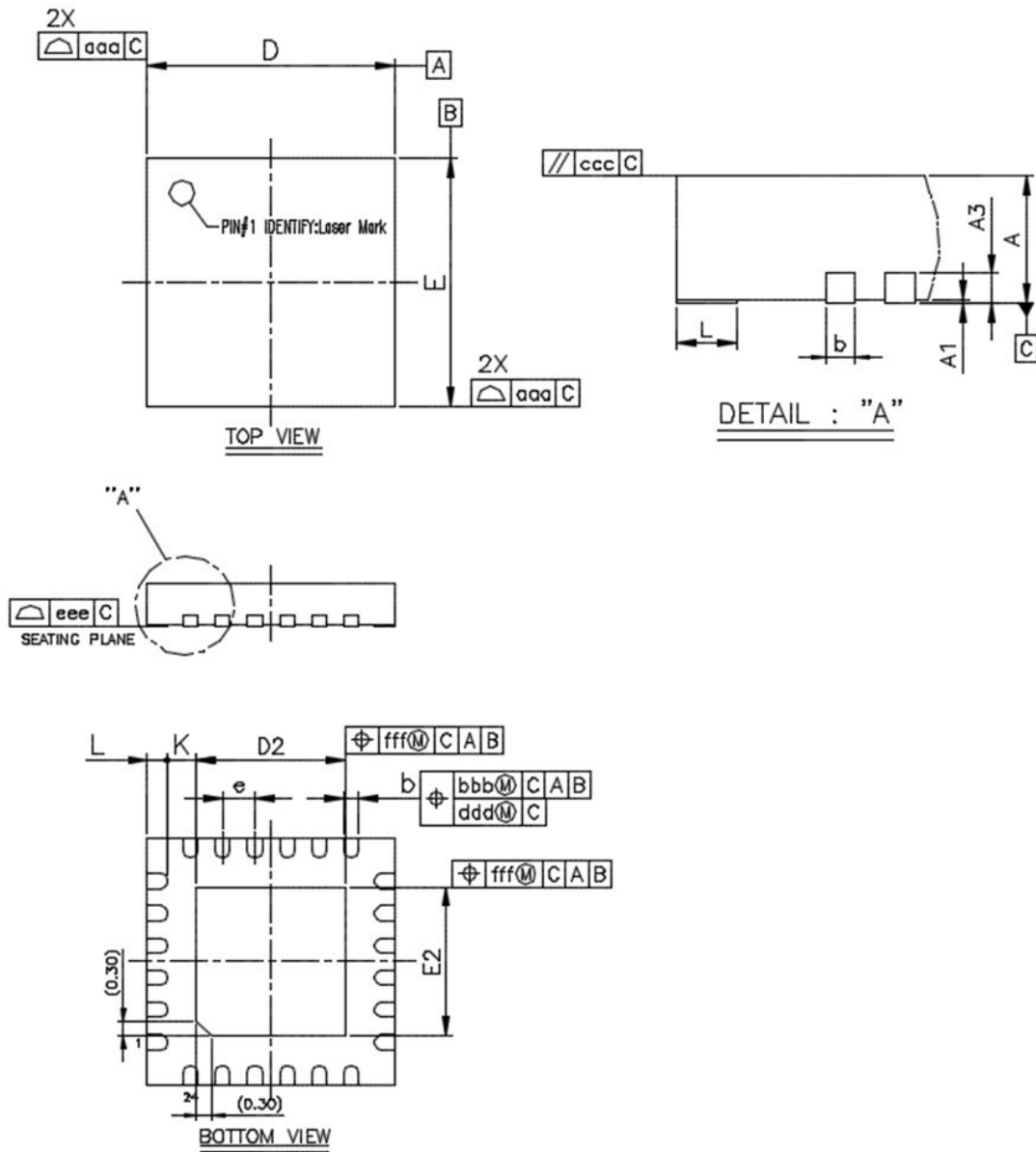

Figure 6.3. 24-Pin, QFN Package

Table 6.3. Package Diagram Dimensions

| Symbol | Min | Nom | Max |
|--------|------|-----------|------|
| A | 0.80 | 0.85 | 0.90 |
| A1 | 0.00 | 0.02 | 0.05 |
| b | 0.25 | 0.30 | 0.35 |
| A3 | | 0.20 REF | |
| D | | 5.00 BSC. | |
| e | | 0.65 BSC. | |
| E | | 5.00 BSC. | |

| Symbol | Min | Nom | Max |
|--------|------|------|------|
| D2 | 2.90 | 3.00 | 3.10 |
| E2 | 2.90 | 3.00 | 3.10 |
| L | 0.35 | 0.40 | 0.45 |
| K | 0.20 | — | — |
| aaa | 0.15 | | |
| bbb | 0.10 | | |
| ccc | 0.10 | | |
| ddd | 0.05 | | |
| eee | 0.08 | | |
| fff | 0.10 | | |

Note:

1. All dimensions shown are in millimeters (mm) unless otherwise noted.
2. Dimensioning and Tolerancing per ANSI Y14.5M-1994.
3. Recommended card reflow profile is per the JEDEC/IPC J-STD-020 specification for Small Body Components.

6.4 Land Pattern: Si34061/62

The figure below illustrates the land pattern details for the Si34061/62. The table lists the values for the dimensions shown in the illustration.

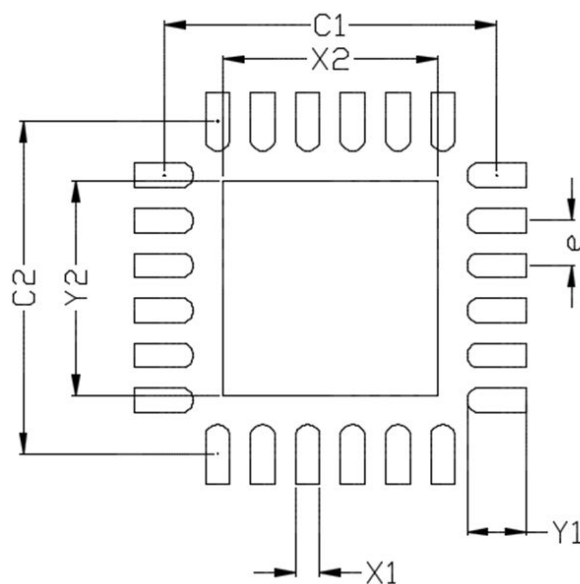

Figure 6.4. 24-Pin, QFN Land Pattern

Table 6.4. Land Pattern Dimensions

| Dimension | mm |
|-----------|------|
| C1 | 4.90 |
| C2 | 4.90 |
| X1 | 0.35 |
| X2 | 3.10 |
| Y1 | 0.85 |
| Y2 | 3.10 |
| e | 0.65 |

Note:

General

1. All dimensions shown are in millimeters (mm) unless otherwise noted
2. This land pattern design is based on the IPC-7351 guidelines

Solder Mask Design

1. All metal pads are to be non-solder mask defined (NSMD). Clearance between the solder mask and the metal pad is to be 60 μm minimum, all the way around the pad.

Stencil Design

1. A stainless steel, laser-cut and electro-polished stencil with trapezoidal walls should be used to assure good solder paste release
2. The stencil thickness should be 0.125 mm (5 mils)
3. The ratio of stencil aperture to land pad size should be 1:1 for all perimeter pads.

Card Assembly

1. A No-Clean, Type-3 solder paste is recommended.
2. The recommended card reflow profile is per the JEDEC/IPC J-STD-020 specification for Small Body Components.

7. Top Markings

7.1 Si3406 Top Marking

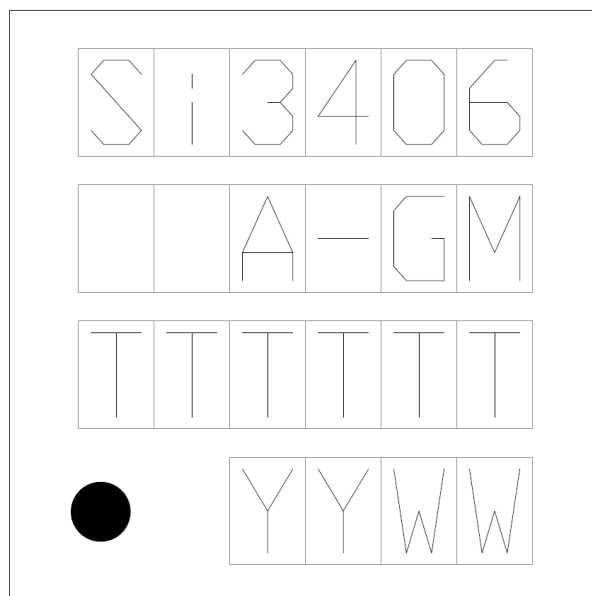

Figure 7.1. Si3406 Top Marking

Table 7.1. Si3406 Top Marking Explanation

| | | |
|----------------------------|-----------------------------------------------|----------------------------------------------------------------------------|
| Mark Method: | Laser | |
| Pin 1 Mark: | Circle = 0.50 mm Diameter (Lower-Left Corner) | |
| Font Size: | 2.0 Point (28 mils) | |
| Line 1 Mark Format: | Device Part Number | Si3406 |
| Line 2 Mark Format: | Device Type | A = Device Revision A G = Extended temperature range M = QFN package |
| Line 3 Mark Format: | TTTTTT | Manufacturing Trace Code (assigned at assembly) |
| Line 4 Mark Format: | YY = Year WW = Work Week | Assembly Year Assembly Week |

7.2 Si34061 Top Marking

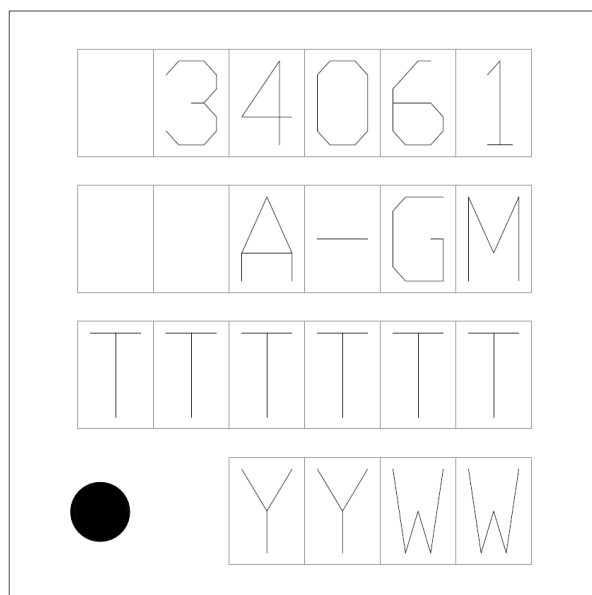

Figure 7.2. Si34061 Top Marking

Table 7.2. Si34061 Top Marking Explanation

| | | |
|----------------------------|-----------------------------------------------|----------------------------------------------------------------------------|
| Mark Method: | Laser | |
| Pin 1 Mark: | Circle = 0.50 mm Diameter (Lower-Left Corner) | |
| Font Size: | 2.0 Point (28 mils) | |
| Line 1 Mark Format: | Device Part Number | Si34061 |
| Line 2 Mark Format: | Device Type | A = Device Revision A G = Extended temperature range M = QFN package |
| Line 3 Mark Format: | TTTTTT | Manufacturing Trace Code (assigned at assembly) |
| Line 4 Mark Format: | YY = Year WW = Work Week | Assembly Year Assembly Week |

7.3 Si34062 Top Marking

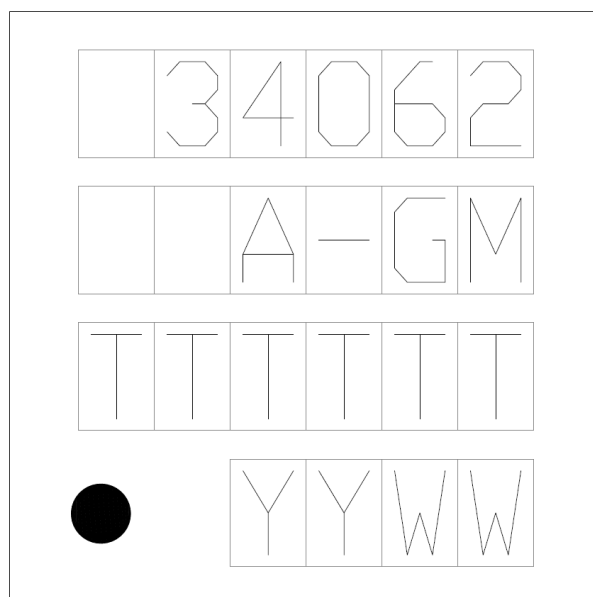

Figure 7.3. Si34062 Top Marking

Table 7.3. Si34062 Top Marking Explanation

| | | |
|----------------------------|-----------------------------------------------|----------------------------------------------------------------------------|
| Mark Method: | Laser | |
| Pin 1 Mark: | Circle = 0.50 mm Diameter (Lower-Left Corner) | |
| Font Size: | 2.0 Point (28 mils) | |
| Line 1 Mark Format: | Device Part Number | Si34062 |
| Line 2 Mark Format: | Device Type | A = Device Revision A G = Extended temperature range M = QFN package |
| Line 3 Mark Format: | TTTTTT | Manufacturing Trace Code (assigned at assembly) |
| Line 4 Mark Format: | YY = Year WW = Work Week | Assembly Year Assembly Week |

8. Revision History

Revision 1.0

December, 2018

- Renamed and reordered sections 2.6, 2.7, 2.8, 2.9, and 2.10. Removed section V0.5 section 2.6 and merged with 2.4.1.
- Replaced [Figure 2.4 Powered Device Voltages on page 6](#) with revised version.
- Replaced [Figure 2.5 Hotswap Switch 4-State Machine on page 7](#) with new version.
- Replaced [Figure 2.6 Si3406x DC-DC Converter Block Diagram on page 8](#) with new version.
- Updated [2.10 External Wall Adapter Support](#) with further detail on external wall adapter support.
 - Updated [Figure 2.9 Auxiliary Wall Adapter Connection Example on page 11](#).
- Updated [4. Electrical Specifications](#),
 - Added min and max current to Peak Current spec.
- Updated [Table 4.1 Absolute Maximum Ratings¹ on page 14](#).
 - Added junction temperature.
- Updated [Table 4.2 Recommended Operating Conditions on page 15](#).
 - Added VPOS-VNEG to VHV_OP spec and updated min voltage based on final characterization data
 - Added note on transition voltages for digital input pins.
- Updated [Table 4.3 Electrical Characteristics on page 16](#).
 - Reworded and corrected V_{DET} spec.
 - Reworded and corrected V_{CLASS} spec.
 - Removed I_{MARK} typ spec.
 - Added min and max specs to V_{UVLO_R} , V_{UVLO_F} , and V_{UVLO_HYST} based on final characterization data.
 - Removed I_{OVL} max and min specs.
 - Added max voltage spec to V_{EXT_DRV} based on final characterization data.
 - Added min and max frequency to F_{OSCINT} based on final characterization data.
 - Removed TBD on DUC.
 - Added min and max spec to V_{FBREF} based on final characterization data.
 - Added T_{HICCUP} spec.
 - Added min and max specs to V_{ISNS_OVC} and V_{ISNS_LC} based on final characterization data.
 - Updated $T_{SOFTSTART}$ based on application data and added note.
 - Updated all Regulators specs based on final characterization data.
 - Updated package thermal characteristics based on final characterization data.
 - Added electrical and junction temperature conditions.
 - P_{INTMAX} specification typical value corrected to 0.2 W.
- Updated [Table 5.1 Pin Descriptions on page 19](#).
 - Updated Vrange.
- Updated [Table 5.2 Circuit Equivalent and Description of Die Pads on page 21](#).
 - Updated V15 and V11 descriptions.

Revision 0.5

February, 2018

- Updated [2. System Overview](#) and [3. Application Examples](#).
 - Added theory of operation and application content.
- Updated [Table 4.1 Absolute Maximum Ratings¹ on page 14](#), [Table 4.2 Recommended Operating Conditions on page 15](#), and [Table 4.3 Electrical Characteristics on page 16](#).
 - Clarified multiple parameters.
- Added [5.1 Detailed Pin Descriptions](#).
- Added [6. Packaging](#) including outline and land pattern.

Revision 0.1

August, 2016

- Initial release.

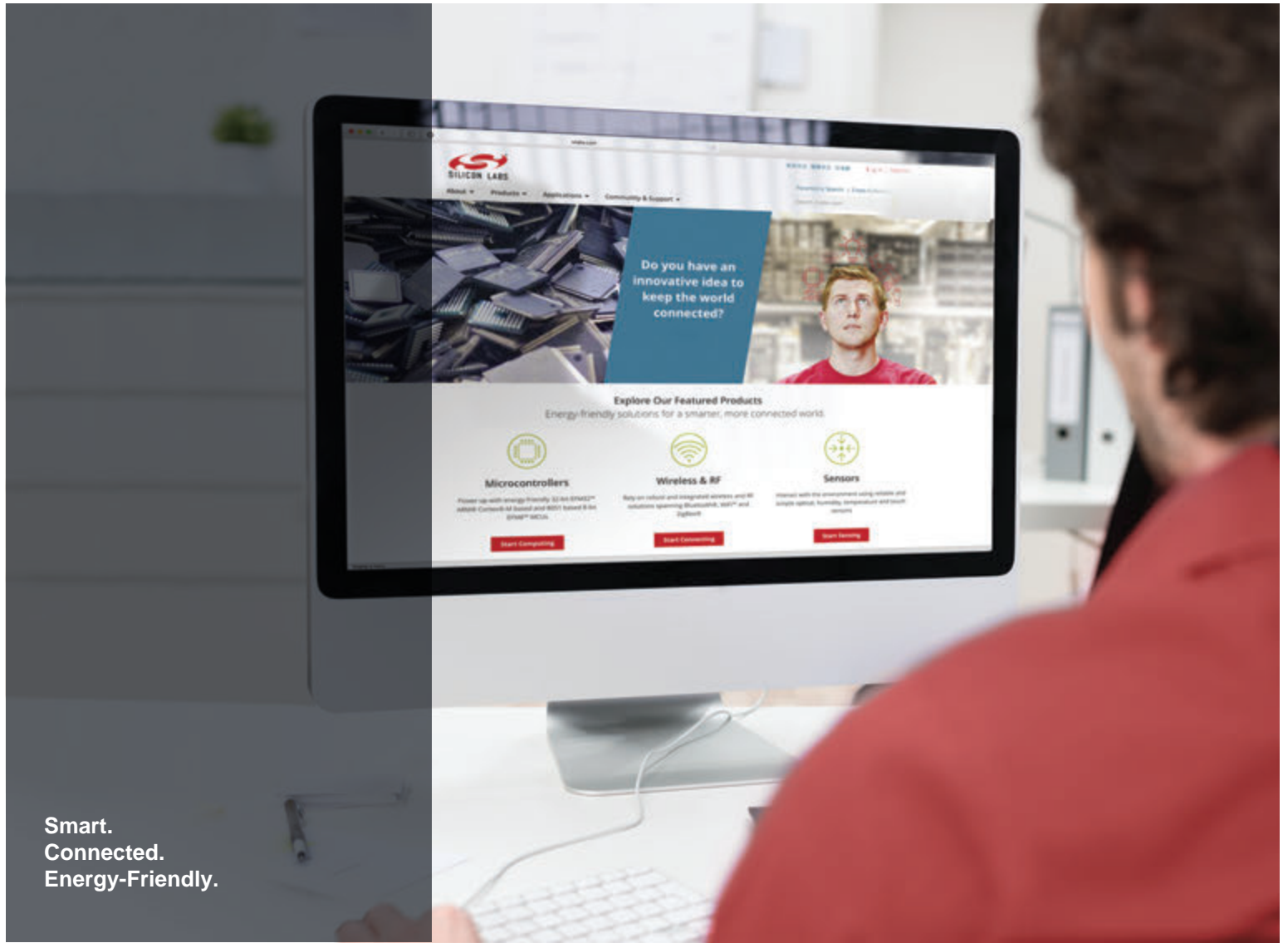

Smart.
Connected.
Energy-Friendly.



Products
www.silabs.com/products

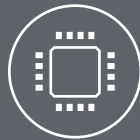

Quality
www.silabs.com/quality



Support and Community
community.silabs.com

Disclaimer
Silicon Labs intends to provide customers with the latest, accurate, and in-depth documentation of all peripherals and modules available for system and software implementers using or intending to use the Silicon Labs products. Characterization data, available modules and peripherals, memory sizes and memory addresses refer to each specific device, and "Typical" parameters provided can and do vary in different applications. Application examples described herein are for illustrative purposes only. Silicon Labs reserves the right to make changes without further notice and limitation to product information, specifications, and descriptions herein, and does not give warranties as to the accuracy or completeness of the included information. Silicon Labs shall have no liability for the consequences of use of the information supplied herein. This document does not imply or express copyright licenses granted hereunder to design or fabricate any integrated circuits. The products are not designed or authorized to be used within any Life Support System without the specific written consent of Silicon Labs. A "Life Support System" is any product or system intended to support or sustain life and/or health, which, if it fails, can be reasonably expected to result in significant personal injury or death. Silicon Labs products are not designed or authorized for military applications. Silicon Labs products shall under no circumstances be used in weapons of mass destruction including (but not limited to) nuclear, biological or chemical weapons, or missiles capable of delivering such weapons.

Trademark Information

Silicon Laboratories Inc.®, Silicon Laboratories®, Silicon Labs®, SiLabs® and the Silicon Labs logo®, Bluegiga®, Bluegiga Logo®, Clockbuilder®, CMEMS®, DSPLL®, EFM®, EFM32®, EFR, Ember®, Energy Micro, Energy Micro logo and combinations thereof, "the world's most energy friendly microcontrollers", Ember®, EZLink®, EZRadio®, EZRadioPRO®, Gecko®, ISOModem®, Micrium, Precision32®, ProSLIC®, Simplicity Studio®, SiPHY®, Telegesis, the Telegesis Logo®, USBXpress®, Zentri, Z-Wave and others are trademarks or registered trademarks of Silicon Labs. ARM, CORTEX, Cortex-M3 and THUMB are trademarks or registered trademarks of ARM Holdings. Keil is a registered trademark of ARM Limited. All other products or brand names mentioned herein are trademarks of their respective holders.



Silicon Laboratories Inc.
400 West Cesar Chavez
Austin, TX 78701
USA

<http://www.silabs.com>

Компания «Life Electronics» занимается поставками электронных компонентов импортного и отечественного производства от производителей и со складов крупных дистрибьюторов Европы, Америки и Азии.

С конца 2013 года компания активно расширяет линейку поставок компонентов по направлению коаксиальный кабель, кварцевые генераторы и конденсаторы (керамические, пленочные, электролитические), за счёт заключения дистрибьюторских договоров

Мы предлагаем:

- Конкурентоспособные цены и скидки постоянным клиентам.
- Специальные условия для постоянных клиентов.
- Подбор аналогов.
- Поставку компонентов в любых объемах, удовлетворяющих вашим потребностям.
- Приемлемые сроки поставки, возможна ускоренная поставка.
- Доставку товара в любую точку России и стран СНГ.
- Комплексную поставку.
- Работу по проектам и поставку образцов.
- Формирование склада под заказчика.
- Сертификаты соответствия на поставляемую продукцию (по желанию клиента).
- Тестирование поставляемой продукции.
- Поставку компонентов, требующих военную и космическую приемку.
- Входной контроль качества.
- Наличие сертификата ISO.

В составе нашей компании организован Конструкторский отдел, призванный помогать разработчикам, и инженерам.

Конструкторский отдел помогает осуществить:

- Регистрацию проекта у производителя компонентов.
- Техническую поддержку проекта.
- Защиту от снятия компонента с производства.
- Оценку стоимости проекта по компонентам.
- Изготовление тестовой платы монтаж и пусконаладочные работы.



Тел: +7 (812) 336 43 04 (многоканальный)
Email: org@lifeelectronics.ru