



KSZ8091MNX/KSZ8091RNB

10Base-T/100Base-TX Physical Layer Transceiver

Revision 1.0

General Description

The KSZ8091 is a single-supply 10Base-T/100Base-TX Ethernet physical-layer transceiver for transmission and reception of data over standard CAT-5 unshielded twisted pair (UTP) cable.

The KSZ8091 is a highly-integrated PHY solution. It reduces board cost and simplifies board layout by using on-chip termination resistors for the differential pairs, by integrating a low-noise regulator to supply the 1.2V core, and by offering a flexible 1.8/2.5/3.3V digital I/O interface.

The KSZ8091MNX offers the Media Independent Interface (MII) and the KSZ8091RNB offers the Reduced Media Independent Interface (RMII) for direct connection with MII/RMII-compliant Ethernet MAC processors and switches.

Energy Efficient Ethernet (EEE) provides further power saving during idle traffic periods and Wake-on-LAN (WOL) provides a mechanism for the KSZ8091 to wake up a system that is in standby power mode.

The KSZ8091 provides diagnostic features to facilitate system bring-up and debugging in production testing and in product deployment. Parametric NAND tree support enables fault detection between KSZ8091 I/Os and the board. Micrel LinkMD[®] TDR-based cable diagnostics identify faulty copper cabling.

The KSZ8091MNX and KSZ8091RNB are available in 32-pin, lead-free QFN packages (see “[Ordering Information](#)”).

Datasheets and support documentation are available on Micrel’s web site at: www.micrel.com.

Features

- Single-chip 10Base-T/100Base-TX IEEE 802.3 compliant Ethernet transceiver
- MII interface support (KSZ8091MNX)
- RMII v1.2 interface support with a 50MHz reference clock output to MAC, and an option to input a 50MHz reference clock (KSZ8091RNB)
- Back-to-back mode support for a 100Mbps copper repeater
- MDC/MDIO management interface for PHY register configuration
- Programmable interrupt output
- LED outputs for link and activity status indication, plus speed indication for KSZ8091RNB
- On-chip termination resistors for the differential pairs
- Baseline wander correction
- HP Auto MDI/MDI-X to reliably detect and correct straight-through and crossover cable connections with disable and enable option
- Auto-negotiation to automatically select the highest link-up speed (10/100Mbps) and duplex (half/full)
- Energy Efficient Ethernet (EEE) support with low-power idle (LPI) mode and clock stoppage (MII version only) for 100Base-TX and transmit amplitude reduction with 10Base-Te option
- Wake-on-LAN (WOL) support with either magic packet, link status change, or robust custom-packet detection

Functional Diagram

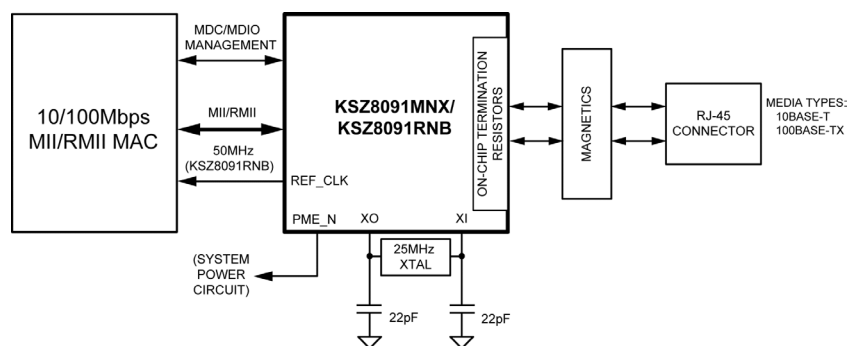

LinkMD is a registered trademark of Micrel, Inc.

Micrel Inc. • 2180 Fortune Drive • San Jose, CA 95131 • USA • tel +1 (408) 944-0800 • fax + 1 (408) 474-1000 • <http://www.micrel.com>

Features (Continued)

- Power-down and power-saving modes
- LinkMD TDR-based cable diagnostics to identify faulty copper cabling
- Parametric NAND Tree support for fault detection between chip I/Os and the board
- Loopback modes for diagnostics
- Single 3.3V power supply with VDD I/O options for 1.8V, 2.5V, or 3.3V
- Built-in 1.2V regulator for core
- Available in 32-pin (5mm x 5mm) QFN package

Applications

- Game console
- IP phone
- IP set-top box
- IP TV
- LOM
- Printer

Ordering Information

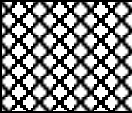
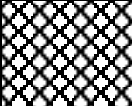
Part Number	Temperature Range	Package	Lead Finish	Wire Bonding	Description
KSZ8091MNXCA	0°C to 70°C	32-Pin QFN	Pb-Free	Gold	MII, EEE and WOL Support, Commercial Temperature, Gold Wire Bonding
KSZ8091MNXIA ⁽¹⁾	-40°C to 85°C	32-Pin QFN	Pb-Free	Gold	MII, EEE and WOL Support, Industrial Temperature, Gold Wire Bonding
KSZ8091RNBCA	0°C to 70°C	32-Pin QFN	Pb-Free	Gold	RMII with 25MHz crystal/clock input and 50MHz RMII REF_CLK output (power-up default), EEE and WOL Support, Commercial Temperature, Gold Wire Bonding
KSZ8091RNBIA ⁽¹⁾	-40°C to 85°C	32-Pin QFN	Pb-Free	Gold	RMII with 25MHz crystal/clock input and 50MHz RMII REF_CLK output (power-up default), EEE and WOL Support, Industrial Temperature, Gold Wire Bonding
KSZ8091MNX-EVAL	0°C to 70°C	32-Pin QFN	Pb-Free		KSZ8091MNX Evaluation Board (Mounted with KSZ8091MNX device in commercial temperature)
KSZ8091RNB-EVAL	0°C to 70°C	32-Pin QFN	Pb-Free		KSZ8091RNB Evaluation Board (Mounted with KSZ8091RNB device in commercial temperature)

Note:

1. Contact factory for availability.

Revision History

Revision	Date	Summary of Changes
1.0	7/2/2013	New datasheet.

Contents

General Description	1
Features	1
Functional Diagram	1
Features (Continued)	2
Applications	2
Ordering Information	2
Revision History	3
Contents	4
List of Figures	6
List of Tables	7
Pin Configuration – KSZ8091MNX	8
Pin Description – KSZ8091MNX	8
Strapping Options – KSZ8091MNX	12
Pin Configuration – KSZ8091RNB	13
Pin Description – KSZ8091RNB	13
Strapping Options – KSZ8091RNB	17
Functional Description: 10Base-T/100Base-TX Transceiver	18
100Base-TX Transmit	18
100Base-TX Receive	18
Scrambler/De-Scrambler (100Base-TX Only)	18
10Base-T Transmit	18
10Base-T Receive	19
SQE and Jabber Function (10Base-T Only)	19
PLL Clock Synthesizer	19
Auto-Negotiation	19
MII Data Interface (KSZ8091MNX only)	20
MII Signal Definition	20
MII Signal Diagram	22
RMII Data Interface (KSZ8091RNB only)	23
RMII – 25MHz Clock Mode	23
RMII – 50MHz Clock Mode	23
RMII Signal Definition	23
RMII Signal Diagram	25
Back-to-Back Mode – 100Mbps Copper Repeater	26
MII Back-to-Back Mode (KSZ8091MNX only)	27
RMII Back-to-Back Mode (KSZ8091RNB only)	27
MII Management (MIIM) Interface	28
Interrupt (INTRP)	28
HP Auto MDI/MDI-X	28
Straight Cable	29
Crossover Cable	29
Loopback Mode	30
Local (Digital) Loopback	30
Remote (Analog) Loopback	31

LinkMD® Cable Diagnostic	32
NAND Tree Support	32
NAND Tree I/O Testing	34
Power Management	34
Power-Saving Mode	35
Energy-Detect Power-Down Mode	35
Power-Down Mode	35
Slow-Oscillator Mode	35
Energy Efficient Ethernet (EEE)	35
Transmit Direction Control (MAC-to-PHY)	36
Receive Direction Control (PHY-to-MAC)	37
Registers Associated with EEE	38
Wake-On-LAN	38
Magic-Packet Detection	38
Customized-Packet Detection	39
Link Status Change Detection	39
Reference Circuit for Power and Ground Connections	40
Typical Current/Power Consumption	41
Transceiver (3.3V), Digital I/Os (3.3V)	41
Transceiver (3.3V), Digital I/Os (2.5V)	41
Transceiver (3.3V), Digital I/Os (1.8V)	42
Register Map	43
Standard Registers	45
IEEE-Defined Registers – Descriptions	45
Vendor-Specific Registers – Descriptions	50
MMD Registers	56
MMD Registers – Descriptions	57
Absolute Maximum Ratings ⁽¹²⁾	62
Operating Ratings ⁽¹³⁾	62
Electrical Characteristics ⁽¹⁴⁾	62
Timing Diagrams	64
MII SQE Timing (10Base-T)	64
MII Transmit Timing (10Base-T)	65
MII Receive Timing (10Base-T)	66
MII Transmit Timing (100Base-TX)	67
MII Receive Timing (100Base-TX)	68
RMII Timing	69
Auto-Negotiation Timing	70
MDC/MDIO Timing	71
Power-Up/Reset Timing	72
Reset Circuit	73
Reference Circuits – LED Strap-In Pins	74
Reference Clock – Connection and Selection	75
Magnetic – Connection and Selection	76
Recommended Land Pattern	78
Package Information ⁽¹⁶⁾	79

List of Figures

Figure 1. Auto-Negotiation Flow Chart.....	20
Figure 2. KSZ8091MNX MII Interface.....	23
Figure 3. KSZ8091RNB RMII Interface (25MHz Clock Mode).....	25
Figure 4. KSZ8091RNB RMII Interface (50MHz Clock Mode).....	26
Figure 5. KSZ8091MNX/RNB to KSZ8091MNX/RNB Back-to-Back Copper Repeater	26
Figure 6. Typical Straight Cable Connection	29
Figure 7. Typical Crossover Cable Connection	30
Figure 8. Local (Digital) Loopback	31
Figure 9. Remote (Analog) Loopback.....	32
Figure 10. LPI Mode (Refresh Transmissions and Quiet Periods).....	36
Figure 11. LPI Transition – MII (100Mbps) Transmit	36
Figure 12. LPI Transition – RMII (100Mbps) Transmit.....	37
Figure 13. LPI Transition – MII (100Mbps) Receive	37
Figure 14. LPI Transition – RMII (100Mbps) Receive.....	38
Figure 15. KSZ8091MNX/RNB Power and Ground Connections	40
Figure 16. MII SQE Timing (10Base-T)	64
Figure 17. MII Transmit Timing (10Base-T).....	65
Figure 18. MII Receive Timing (10Base-T).....	66
Figure 19. MII Transmit Timing (100Base-TX).....	67
Figure 20. MII Receive Timing (100Base-TX).....	68
Figure 21. RMII Timing – Data Received from RMII	69
Figure 22. RMII Timing – Data Input to RMII	69
Figure 23. Auto-Negotiation Fast Link Pulse (FLP) Timing	70
Figure 24. MDC/MDIO Timing.....	71
Figure 25. Power-Up/Reset Timing.....	72
Figure 26. Recommended Reset Circuit.....	73
Figure 27. Recommended Reset Circuit for Interfacing with CPU/FPGA Reset Output	73
Figure 28. Reference Circuits for LED Strapping Pins.....	74
Figure 29. 25MHz Crystal/Oscillator Reference Clock Connection	75
Figure 30. 50MHz Oscillator Reference Clock Connection	75
Figure 31. Typical Magnetic Interface Circuit.....	76
Figure 32. Recommended Land Pattern, 32-Pin (5mm x 5mm) QFN	78

List of Tables

Table 1. MII Signal Definition	21
Table 2. RMII Signal Definition.....	24
Table 3. MII Signal Connection for MII Back-to-Back Mode (100Base-TX Copper Repeater).....	27
Table 4. RMII Signal Connection for RMII Back-to-Back Mode (100Base-TX Copper Repeater)	27
Table 5. MII Management Frame Format for the KSZ8091MNX/RNB	28
Table 6. MDI/MDI-X Pin Definition	29
Table 7. NAND Tree Test Pin Order for KSZ8091MNX.....	33
Table 8. NAND Tree Test Pin Order for KSZ8091RNB	34
Table 9. KSZ8091MNX/RNB Power Pin Description.....	40
Table 10. Typical Current/Power Consumption (VDDA_3.3 = 3.3V, VDDIO = 3.3V)	41
Table 11. Typical Current/Power Consumption (VDDA_3.3 = 3.3V, VDDIO = 2.5V).....	41
Table 12. Typical Current/Power Consumption (VDDA_3.3 = 3.3V, VDDIO = 1.8V).....	42
Table 13. Standard Registers Supported by KSZ8091MNX/RNB	43
Table 14. MMD Registers Supported by KSZ8091MNX/RNB.....	44
Table 15. Portal Registers (Access to Indirect MMD Registers).....	56
Table 16. MII SQE Timing (10Base-T) Parameters.....	64
Table 17. MII Transmit Timing (10Base-T) Parameters	65
Table 18. MII Receive Timing (10Base-T) Parameters.....	66
Table 19. MII Transmit Timing (100Base-TX) Parameters	67
Table 20. MII Receive Timing (100Base-TX) Parameters	68
Table 21. RMII Timing Parameters – KSZ8091RNB (25MHz input to XI pin, 50MHz output from REF_CLK pin)	69
Table 22. RMII Timing Parameters – KSZ8091RNB (50MHz input to XI pin)	69
Table 23. Auto-Negotiation Fast Link Pulse (FLP) Timing Parameters	70
Table 24. MDC/MDIO Timing Parameters	71
Table 25. Power-Up/Reset Timing Parameters	72
Table 26. 25MHz Crystal / Reference Clock Selection Criteria	75
Table 27. 50MHz Oscillator / Reference Clock Selection Criteria	75
Table 28. Magnetics Selection Criteria	77
Table 29. Compatible Single-Port 10/100 Magnetics.....	77

Pin Configuration – KSZ8091MNX

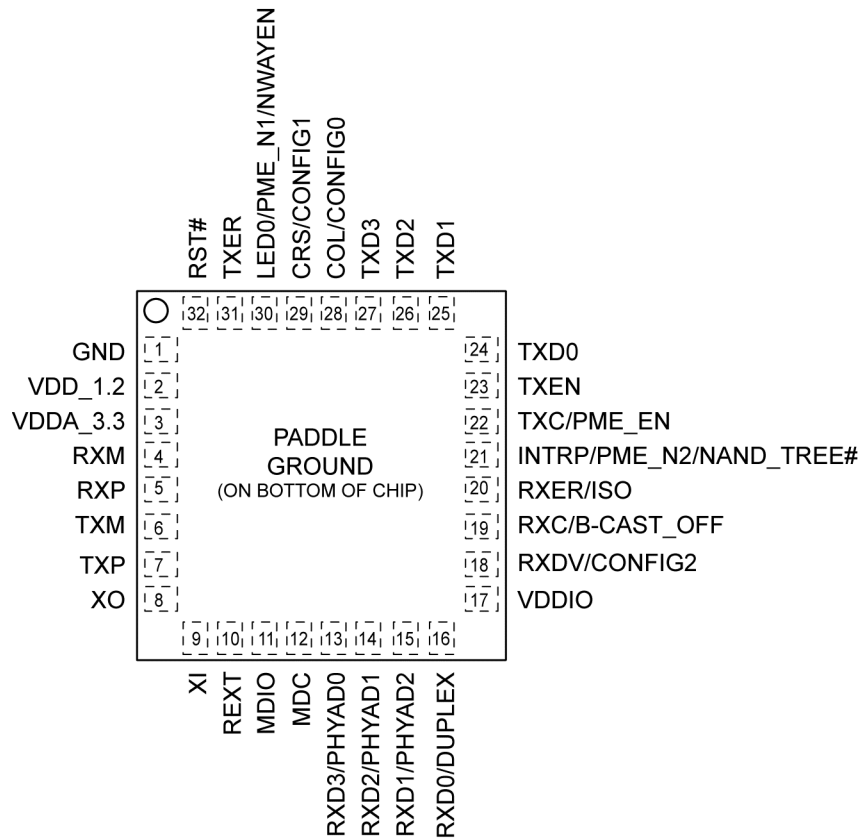

32-Pin (5mm x 5mm) QFN

Pin Description – KSZ8091MNX

Pin Number	Pin Name	Type ⁽²⁾	Pin Function
1	GND	Gnd	Ground
2	VDD_1.2	P	1.2V core V _{DD} (power supplied by KSZ8091MNX) Decouple with 2.2μF and 0.1μF capacitors to ground.
3	VDDA_3.3	P	3.3V analog V _{DD}
4	RXM	I/O	Physical receive or transmit signal (– differential)
5	RXP	I/O	Physical receive or transmit signal (+ differential)
6	TXM	I/O	Physical transmit or receive signal (– differential)
7	TXP	I/O	Physical transmit or receive signal (+ differential)
8	XO	O	Crystal feedback for 25MHz crystal This pin is a no connect if an oscillator or external clock source is used.
9	XI	I	Crystal / Oscillator / External Clock input 25MHz ±50ppm

Pin Number	Pin Name	Type ⁽²⁾	Pin Function
10	REXT	I	Set PHY transmit output current Connect a 6.49kΩ resistor to ground on this pin.
11	MDIO	Ipu/Opu	Management Interface (MII) Data I/O This pin has a weak pull-up, is open-drain, and requires an external 1.0kΩ pull-up resistor.
12	MDC	Ipu	Management Interface (MII) Clock input This clock pin is synchronous to the MDIO data pin.
13	RXD3/ PHYAD0	Ipu/O	MII mode: MII Receive Data Output[3] ⁽³⁾ Config mode: The pull-up/pull-down value is latched as PHYADDR[0] at the de-assertion of reset. See the “ Strapping Options – KSZ8091MNX ” section for details.
14	RXD2/ PHYAD1	Ipd/O	MII mode: MII Receive Data Output[2] ⁽³⁾ Config mode: The pull-up/pull-down value is latched as PHYADDR[1] at the de-assertion of reset. See the “ Strapping Options – KSZ8091MNX ” section for details.
15	RXD1/ PHYAD2	Ipd/O	MII mode: MII Receive Data Output[1] ⁽³⁾ Config mode: The pull-up/pull-down value is latched as PHYADDR[2] at the de-assertion of reset. See the “ Strapping Options – KSZ8091MNX ” section for details.
16	RXD0/ DUPLEX	Ipu/O	MII mode: MII Receive Data Output[0] ⁽³⁾ Config mode: The pull-up/pull-down value is latched as DUPLEX at the de-assertion of reset. See the “ Strapping Options – KSZ8091MNX ” section for details.
17	VDDIO	P	3.3V, 2.5V, or 1.8V digital V _{DD}
18	RXDV/ CONFIG2	Ipd/O	MII mode: MII Receive Data Valid output Config mode: The pull-up/pull-down value is latched as CONFIG2 at the de-assertion of reset. See the “ Strapping Options – KSZ8091MNX ” section for details.
19	RXC/ B-CAST_OFF	Ipd/O	MII mode: MII Receive Clock output Config mode: The pull-up/pull-down value is latched as B-CAST_OFF at the de-assertion of reset. See the “ Strapping Options – KSZ8091MNX ” section for details.
20	RXER/ ISO	Ipd/O	MII mode: MII Receive Error output Config mode: The pull-up/pull-down value is latched as ISOLATE at the de-assertion of reset. See the “ Strapping Options – KSZ8091MNX ” section for details.

Pin Number	Pin Name	Type ⁽²⁾	Pin Function
21	INTRP/ PME_N2/ NAND_Tree#	lpu/Opu	<p>Interrupt output: Programmable interrupt output, with Register 1Bh as the Interrupt Control/Status register, for programming the interrupt conditions and reading the interrupt status. Register 1Fh, bit [9] sets the interrupt output to active low (default) or active high.</p> <p>PME_N output: Programmable PME_N output (pin option 2). When asserted low, this pin signals that a WOL event has occurred.</p> <p>Config mode: The pull-up/pull-down value is latched as NAND Tree# at the de-assertion of reset. See the “Strapping Options – KSZ8091MNX” section for details.</p> <p>This pin has a weak pull-up and is an open-drain. For Interrupt (when active low) and PME functions, this pin requires an external 1.0kΩ pull-up resistor to VDDIO (digital V_{DD}).</p>
22	TXC/ PME_EN	lpd/O	<p>MII mode: MII Transmit Clock output</p> <p>MII back-to-back mode: MII Transmit Clock input</p> <p>Config mode: The pull-up/pull-down value is latched as PME_EN at the de-assertion of reset. See the “Strapping Options – KSZ8091MNX” section for details.</p>
23	TXEN	I	MII mode: MII Transmit Enable input
24	TXD0	I	MII mode: MII Transmit Data Input[0] ⁽⁴⁾
25	TXD1	I	MII mode: MII Transmit Data Input[1] ⁽⁴⁾
26	TXD2	I	MII mode: MII Transmit Data Input[2] ⁽⁴⁾
27	TXD3	I	MII Mode: MII Transmit Data Input[3] ⁽⁴⁾
28	COL/ CONFIG0	lpd/O	<p>MII mode: MII Collision Detect output</p> <p>Config mode: The pull-up/pull-down value is latched as CONFIG0 at the de-assertion of reset. See the “Strapping Options – KSZ8091MNX” section for details.</p>
29	CRS/ CONFIG1	lpd/O	<p>MII mode: MII Carrier Sense output</p> <p>Config mode: The pull-up/pull-down value is latched as CONFIG1 at the de-assertion of reset. See the “Strapping Options – KSZ8091MNX” section for details.</p>

Pin Number	Pin Name	Type ⁽²⁾	Pin Function																											
30	LED0/ PME_N1/ NWAYEN	Ipu/O	<p>LED output: Programmable LED0 output</p> <p>PME_N Output: Programmable PME_N Output (pin option 1)</p> <p>In this mode, this pin has a weak pull-up, is an open-drain, and requires an external 1.0KΩ pull-up resistor to VDDIO (digital V_{DD}).</p> <p>Config mode: Latched as auto-negotiation enable (Register 0h, bit [12]) at the deassertion of reset.</p> <p>See the “Strapping Options – KSZ8091MNX” section for details.</p> <p>The LED0 pin is programmable using Register 1Fh bits [5:4], and is defined as follows.</p> <table border="1" style="margin-left: 20px;"> <thead> <tr> <th colspan="3">LED mode = [00]</th> </tr> <tr> <th>Link/Activity</th> <th>Pin State</th> <th>LED Definition</th> </tr> </thead> <tbody> <tr> <td>No link</td> <td>High</td> <td>OFF</td> </tr> <tr> <td>Link</td> <td>Low</td> <td>ON</td> </tr> <tr> <td>Activity</td> <td>Toggle</td> <td>Blinking</td> </tr> </tbody> </table> <table border="1" style="margin-left: 20px;"> <thead> <tr> <th colspan="3">LED mode = [01]</th> </tr> <tr> <th>Link</th> <th>Pin State</th> <th>LED Definition</th> </tr> </thead> <tbody> <tr> <td>No link</td> <td>High</td> <td>OFF</td> </tr> <tr> <td>Link</td> <td>Low</td> <td>ON</td> </tr> </tbody> </table> <p>LED mode = [10], [11] Reserved</p>	LED mode = [00]			Link/Activity	Pin State	LED Definition	No link	High	OFF	Link	Low	ON	Activity	Toggle	Blinking	LED mode = [01]			Link	Pin State	LED Definition	No link	High	OFF	Link	Low	ON
LED mode = [00]																														
Link/Activity	Pin State	LED Definition																												
No link	High	OFF																												
Link	Low	ON																												
Activity	Toggle	Blinking																												
LED mode = [01]																														
Link	Pin State	LED Definition																												
No link	High	OFF																												
Link	Low	ON																												
31	TXER	Ipd	<p>MII mode: MII Transmit Error input</p> <p>For EEE mode, this pin is driven by the EEE-MAC to put the KSZ8091MNX transmit into the LPI state.</p> <p>For non-EEE mode, this pin is not defined for error transmission from MAC to KSZ8091MNX and can be left as a no connect.</p>																											
32	RST#	Ipu	Chip reset (active low)																											
PADDLE	GND	Gnd	Ground																											

Notes:

2. P = Power supply.
 Gnd = Ground.
 I = Input.
 O = Output.
 I/O = Bi-directional.
 Ipu = Input with internal pull-up (see “[Electrical Characteristics\(14\)](#)” for value).
 Ipd = Input with internal pull-down (see “[Electrical Characteristics\(14\)](#)” for value).
 Ipu/O = Input with internal pull-up (see “[Electrical Characteristics\(14\)](#)” for value) during power-up/reset; output pin otherwise.
 Ipd/O = Input with internal pull-down (see “[Electrical Characteristics\(14\)](#)” for value) during power-up/reset; output pin otherwise.
 Ipu/Opu = Input with internal pull-up (see “[Electrical Characteristics\(14\)](#)” for value) and output with internal pull-up (see “[Electrical Characteristics\(14\)](#)” for value).
3. MII RX Mode: The RXD[3:0] bits are synchronous with RXC. When RXDV is asserted, RXD[3:0] presents valid data to the MAC.
4. MII TX Mode: The TXD[3:0] bits are synchronous with TXC. When TXEN is asserted, TXD[3:0] presents valid data from the MAC.

Strapping Options – KSZ8091MNX

Pin Number	Pin Name	Type ⁽⁵⁾	Pin Function								
15	PHYAD2	lpd/O	PHYAD[2:0] is latched at de-assertion of reset and is configurable to any value from 0 to 7 with PHY Address 1 as the default value. PHY Address 0 is assigned by default as the broadcast PHY address, but it can be assigned as a unique PHY address after pulling the B-CAST_OFF strapping pin high or writing a '1' to Register 16h, bit [9]. PHY Address bits [4:3] are set to 00 by default.								
14	PHYAD1	lpd/O									
13	PHYAD0	lpu/O									
18	CONFIG2	lpd/O	The CONFIG[2:0] strap-in pins are latched at the de-assertion of reset. <table border="1" style="margin-left: 20px;"> <thead> <tr> <th>CONFIG[2:0]</th> <th>Mode</th> </tr> </thead> <tbody> <tr> <td>000</td> <td>MII (default)</td> </tr> <tr> <td>110</td> <td>MII back-to-back</td> </tr> <tr> <td>001–101, 111</td> <td>Reserved – not used</td> </tr> </tbody> </table>	CONFIG[2:0]	Mode	000	MII (default)	110	MII back-to-back	001–101, 111	Reserved – not used
CONFIG[2:0]	Mode										
000	MII (default)										
110	MII back-to-back										
001–101, 111	Reserved – not used										
29	CONFIG1	lpd/O									
28	CONFIG0	lpd/O									
22	PME_EN	lpd/O	PME output for Wake-on-LAN Pull-up = Enable Pull-down (default) = Disable At the de-assertion of reset, this pin value is latched into Register 16h, bit [15].								
20	ISO	lpd/O	Isolate mode Pull-up = Enable Pull-down (default) = Disable At the de-assertion of reset, this pin value is latched into Register 0h, bit [10].								
16	DUPLEX	lpu/O	Duplex mode Pull-up (default) = Half-duplex Pull-down = Full-duplex At the de-assertion of reset, this pin value is latched into Register 0h, bit [8].								
30	NWAYEN	lpu/O	Nway auto-negotiation enable Pull-up (default) = Enable auto-negotiation Pull-down = Disable auto-negotiation At the de-assertion of reset, this pin value is latched into Register 0h, bit [12].								
19	B-CAST_OFF	lpd/O	Broadcast off – for PHY Address 0 Pull-up = PHY Address 0 is set as an unique PHY address Pull-down (default) = PHY Address 0 is set as a broadcast PHY address At the de-assertion of reset, this pin value is latched by the chip.								
21	NAND_Tree#	lpu/Opu	NAND tree mode Pull-up (default) = Disable Pull-down = Enable At the de-assertion of reset, this pin value is latched by the chip.								

Note:

5. lpu/O = Input with internal pull-up (see “[Electrical Characteristics\(14\)](#)” for value) during power-up/reset; output pin otherwise.
 lpd/O = Input with internal pull-down (see “[Electrical Characteristics\(14\)](#)” for value) during power-up/reset; output pin otherwise.
 lpu/Opu = Input with internal pull-up (see “[Electrical Characteristics\(14\)](#)” for value) and output with internal pull-up (see “[Electrical Characteristics\(14\)](#)” for value).

The strap-in pins are latched at the de-assertion of reset. In some systems, the MAC MII receive input pins may drive high/low during power-up or reset, and consequently cause the PHY strap-in pins on the MII signals to be latched to unintended high/low states. In this case, external pull-ups (4.7kΩ) or pull-downs (1.0kΩ) should be added on these PHY strap-in pins to ensure that the intended values are strapped-in correctly.

Pin Configuration – KSZ8091RNB

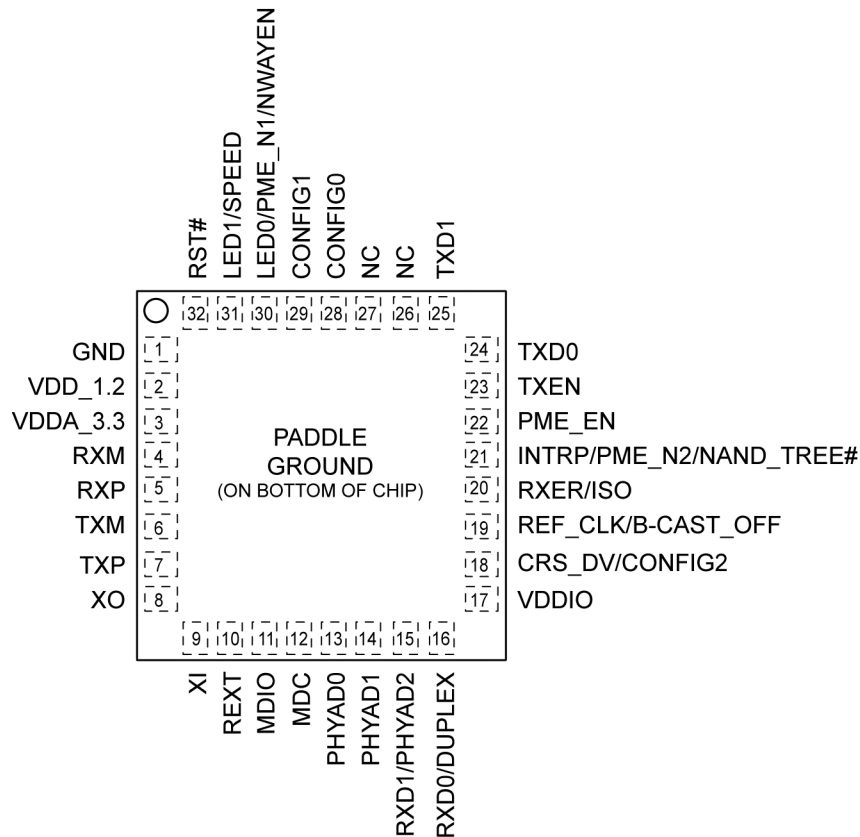

32-Pin (5mm x 5mm) QFN

Pin Description – KSZ8091RNB

Pin Number	Pin Name	Type ⁽⁶⁾	Pin Function
1	GND	Gnd	Ground
2	VDD_1.2	P	1.2V core V _{DD} (power supplied by KSZ8091RNB) Decouple with 2.2μF and 0.1μF capacitors to ground.
3	VDDA_3.3	P	3.3V analog V _{DD}
4	RXM	I/O	Physical receive or transmit signal (– differential)
5	RXP	I/O	Physical receive or transmit signal (+ differential)
6	TXM	I/O	Physical transmit or receive signal (– differential)
7	TXP	I/O	Physical transmit or receive signal (+ differential)
8	XO	O	Crystal feedback for 25MHz crystal This pin is a no connect if an oscillator or external clock source is used.
9	XI	I	25MHz Mode: 25MHz ±50ppm Crystal / Oscillator / External Clock Input 50MHz Mode: 50MHz ±50ppm Oscillator / External Clock Input

Pin Number	Pin Name	Type ⁽⁶⁾	Pin Function
10	REXT	I	Set PHY transmit output current Connect a 6.49kΩ resistor to ground on this pin.
11	MDIO	Ipu/Opu	Management Interface (MII) Data I/O This pin has a weak pull-up, is open-drain, and requires an external 1.0kΩ pull-up resistor.
12	MDC	Ipu	Management Interface (MII) Clock input This clock pin is synchronous to the MDIO data pin.
13	PHYAD0	Ipu/O	The pull-up/pull-down value is latched as PHYADDR[0] at the de-assertion of reset. See the “ Strapping Options – KSZ8091RNB ” section for details.
14	PHYAD1	Ipd/O	The pull-up/pull-down value is latched as PHYADDR[1] at the de-assertion of reset. See the “ Strapping Options – KSZ8091RNB ” section for details.
15	RXD1/ PHYAD2	Ipd/O	RMII mode: RMII Receive Data Output[1] ⁽⁷⁾ Config mode: The pull-up/pull-down value is latched as PHYADDR[2] at the de-assertion of reset. See the “ Strapping Options – KSZ8091RNB ” section for details.
16	RXD0/ DUPLEX	Ipu/O	RMII mode: RMII Receive Data Output[0] ⁽⁷⁾ Config mode: The pull-up/pull-down value is latched as DUPLEX at the de-assertion of reset. See the “ Strapping Options – KSZ8091RNB ” section for details.
17	VDDIO	P	3.3V, 2.5V, or 1.8V digital V _{DD}
18	CRS_DV/ CONFIG2	Ipd/O	RMII mode: RMII Carrier Sense/Receive Data Valid output Config mode: The pull-up/pull-down value is latched as CONFIG2 at the de-assertion of reset. See the “ Strapping Options – KSZ8091RNB ” section for details.
19	REF_CLK/ B-CAST_OFF	Ipd/O	RMII mode: 25MHz mode: This pin provides the 50MHz RMII reference clock output to the MAC. See also XI (pin 9). 50MHz mode: This pin is a no connect. See also XI (pin 9). Config mode: The pull-up/pull-down value is latched as B-CAST_OFF at the de-assertion of reset. See the “ Strapping Options – KSZ8091RNB ” section for details.
20	RXER/ ISO	Ipd/O	RMII mode: RMII Receive Error output Config mode: The pull-up/pull-down value is latched as ISOLATE at the de-assertion of reset. See the “ Strapping Options – KSZ8091RNB ” section for details.

Pin Number	Pin Name	Type ⁽⁶⁾	Pin Function																											
21	INTRP/ PME_N2/ NAND_Tree#	lpu/Opu	<p>Interrupt output: Programmable interrupt output, with Register 1Bh as the Interrupt Control/Status register, for programming the interrupt conditions and reading the interrupt status. Register 1Fh, bit [9] sets the interrupt output to active low (default) or active high.</p> <p>PME_N output: Programmable PME_N output (pin option 2). When asserted low, this pin signals that a WOL event has occurred.</p> <p>Config mode: The pull-up/pull-down value is latched as NAND Tree# at the de-assertion of reset. See the “Strapping Options – KSZ8091RNB” section for details.</p> <p>This pin has a weak pull-up and is an open-drain. For Interrupt (when active low) and PME functions, this pin requires an external 1.0kΩ pull-up resistor to VDDIO (digital V_{DD}).</p>																											
22	PME_EN	lpd/O	<p>The pull-up/pull-down value is latched as PME_EN at the de-assertion of reset. See the “Strapping Options – KSZ8091RNB” section for details.</p>																											
23	TXEN	I	RMIIT Transmit Enable input																											
24	TXD0	I	RMIIT Transmit Data Input[0] ⁽⁸⁾																											
25	TXD1	I	RMIIT Transmit Data Input[1] ⁽⁸⁾																											
26	NC	NC	No connect – This pin is not bonded and can be left floating.																											
27	NC	NC	No connect – This pin is not bonded and can be left floating.																											
28	CONFIG0	lpd/O	<p>The pull-up/pull-down value is latched as CONFIG0 at the de-assertion of reset. See the “Strapping Options – KSZ8091RNB” section for details.</p>																											
29	CONFIG1	lpd/O	<p>The pull-up/pull-down value is latched as CONFIG1 at the de-assertion of reset. See the “Strapping Options – KSZ8091RNB” section for details.</p>																											
30	LED0/ PME_N1/ NWAYEN	lpu/O	<p>LED output: Programmable LED0 output</p> <p>PME_N Output: Programmable PME_N Output (pin option 1) In this mode, this pin has a weak pull-up, is an open-drain, and requires an external 1.0kΩ pull-up resistor to VDDIO (digital V_{DD}).</p> <p>Config mode: Latched as auto-negotiation enable (Register 0h, bit [12]) at the de-assertion of reset. See the “Strapping Options – KSZ8091RNB” section for details.</p> <p>The LED0 pin is programmable using Register 1Fh bits [5:4], and is defined as follows.</p> <table border="1" style="margin-left: 20px;"> <thead> <tr> <th colspan="3">LED mode = [00]</th> </tr> <tr> <th>Link/Activity</th> <th>Pin State</th> <th>LED Definition</th> </tr> </thead> <tbody> <tr> <td>No link</td> <td>High</td> <td>OFF</td> </tr> <tr> <td>Link</td> <td>Low</td> <td>ON</td> </tr> <tr> <td>Activity</td> <td>Toggle</td> <td>Blinking</td> </tr> </tbody> </table> <table border="1" style="margin-left: 20px;"> <thead> <tr> <th colspan="3">LED mode = [01]</th> </tr> <tr> <th>Link</th> <th>Pin State</th> <th>LED Definition</th> </tr> </thead> <tbody> <tr> <td>No link</td> <td>High</td> <td>OFF</td> </tr> <tr> <td>Link</td> <td>Low</td> <td>ON</td> </tr> </tbody> </table> <p>LED mode = [10], [11] Reserved</p>	LED mode = [00]			Link/Activity	Pin State	LED Definition	No link	High	OFF	Link	Low	ON	Activity	Toggle	Blinking	LED mode = [01]			Link	Pin State	LED Definition	No link	High	OFF	Link	Low	ON
LED mode = [00]																														
Link/Activity	Pin State	LED Definition																												
No link	High	OFF																												
Link	Low	ON																												
Activity	Toggle	Blinking																												
LED mode = [01]																														
Link	Pin State	LED Definition																												
No link	High	OFF																												
Link	Low	ON																												

Pin Number	Pin Name	Type ⁽⁶⁾	Pin Function																								
31	LED1/ SPEED	Ipu/O	<p>LED output: Programmable LED1 output</p> <p>Config mode: Latched as Speed (Register 0h, bit [13]) at the de-assertion of reset.</p> <p>See the “Strapping Options – KSZ8091RNB” section for details.</p> <p>The LED1 pin is programmable using Register 1Fh bits [5:4], and is defined as follows.</p> <table border="1" style="margin-left: 20px;"> <thead> <tr> <th colspan="3">LED mode = [00]</th> </tr> <tr> <th>Speed</th> <th>Pin State</th> <th>LED Definition</th> </tr> </thead> <tbody> <tr> <td>10Base-T</td> <td>High</td> <td>OFF</td> </tr> <tr> <td>100Base-TX</td> <td>Low</td> <td>ON</td> </tr> </tbody> </table> <table border="1" style="margin-left: 20px;"> <thead> <tr> <th colspan="3">LED mode = [01]</th> </tr> <tr> <th>Activity</th> <th>Pin State</th> <th>LED Definition</th> </tr> </thead> <tbody> <tr> <td>No activity</td> <td>High</td> <td>OFF</td> </tr> <tr> <td>Activity</td> <td>Toggle</td> <td>Blinking</td> </tr> </tbody> </table> <p>LED mode = [10], [11] Reserved</p>	LED mode = [00]			Speed	Pin State	LED Definition	10Base-T	High	OFF	100Base-TX	Low	ON	LED mode = [01]			Activity	Pin State	LED Definition	No activity	High	OFF	Activity	Toggle	Blinking
LED mode = [00]																											
Speed	Pin State	LED Definition																									
10Base-T	High	OFF																									
100Base-TX	Low	ON																									
LED mode = [01]																											
Activity	Pin State	LED Definition																									
No activity	High	OFF																									
Activity	Toggle	Blinking																									
32	RST#	Ipu	Chip reset (active low)																								
PADDLE	GND	Gnd	Ground																								

Notes:

6. P = Power supply.
 Gnd = Ground.
 I = Input.
 O = Output.
 I/O = Bi-directional.
 Ipu = Input with internal pull-up (see “[Electrical Characteristics\(14\)](#)” for value).
 Ipu/O = Input with internal pull-up (see “[Electrical Characteristics\(14\)](#)” for value) during power-up/reset; output pin otherwise.
 Ipd/O = Input with internal pull-down (see [Electrical Characteristics\(14\)](#)” for value) during power-up/reset; output pin otherwise.
 Ipu/Opu = Input with internal pull-up (see “[Electrical Characteristics\(14\)](#)” for value) and output with internal pull-up (see “[Electrical Characteristics\(14\)](#)” for value).
 NC = Pin is not bonded to the die.
7. RMIIX Mode: The RXD[1:0] bits are synchronous with the 50MHz RMIIX Reference Clock. For each clock period in which CRS_DV is asserted, two bits of recovered data are sent by the PHY to the MAC.
8. RMIIX TX Mode: The TXD[1:0] bits are synchronous with the 50MHz RMIIX Reference Clock. For each clock period in which TXEN is asserted, two bits of data are received by the PHY from the MAC.

Strapping Options – KSZ8091RNB

Pin Number	Pin Name	Type ⁽⁵⁾	Pin Function								
15	PHYAD2	lpd/O	PHYAD[2:0] is latched at de-assertion of reset and is configurable to any value from 0 to 7 with PHY Address 1 as the default value. PHY Address 0 is assigned by default as the broadcast PHY address, but it can be assigned as a unique PHY address after pulling the B-CAST_OFF strapping pin high or writing a '1' to Register 16h, bit [9]. PHY Address bits [4:3] are set to 00 by default.								
14	PHYAD1	lpd/O									
13	PHYAD0	lpu/O									
18	CONFIG2	lpd/O	<p>The CONFIG[2:0] strap-in pins are latched at the de-assertion of reset.</p> <table border="1"> <thead> <tr> <th>CONFIG[2:0]</th> <th>Mode</th> </tr> </thead> <tbody> <tr> <td>001</td> <td>RMII</td> </tr> <tr> <td>101</td> <td>RMII back-to-back</td> </tr> <tr> <td>000, 010–100, 110, 111</td> <td>Reserved – not used</td> </tr> </tbody> </table>	CONFIG[2:0]	Mode	001	RMII	101	RMII back-to-back	000, 010–100, 110, 111	Reserved – not used
CONFIG[2:0]	Mode										
001	RMII										
101	RMII back-to-back										
000, 010–100, 110, 111	Reserved – not used										
29	CONFIG1	lpd/O									
28	CONFIG0	lpd/O									
22	PME_EN	lpd/O	<p>PME output for Wake-on-LAN</p> <p>Pull-up = Enable</p> <p>Pull-down (default) = Disable</p> <p>At the de-assertion of reset, this pin value is latched into Register 16h, bit [15].</p>								
20	ISO	lpd/O	<p>Isolate mode</p> <p>Pull-up = Enable</p> <p>Pull-down (default) = Disable</p> <p>At the de-assertion of reset, this pin value is latched into register 0h, bit [10].</p>								
31	SPEED	lpu/O	<p>Speed mode</p> <p>Pull-up (default) = 100Mbps</p> <p>Pull-down = 10Mbps</p> <p>At the de-assertion of reset, this pin value is latched into Register 0h, bit [13] as the speed select, and also is latched into Register 4h (auto-negotiation advertisement) as the speed capability support.</p>								
16	DUPLEX	lpu/O	<p>Duplex mode</p> <p>Pull-up (default) = Half-duplex</p> <p>Pull-down = Full-duplex</p> <p>At the de-assertion of reset, this pin value is latched into Register 0h, bit [8].</p>								
30	NWAYEN	lpu/O	<p>Nway auto-negotiation enable</p> <p>Pull-up (default) = Enable auto-negotiation</p> <p>Pull-down = Disable auto-negotiation</p> <p>At the de-assertion of reset, this pin value is latched into Register 0h, bit [12].</p>								
19	B-CAST_OFF	lpd/O	<p>Broadcast off – for PHY Address 0</p> <p>Pull-up = PHY Address 0 is set as an unique PHY address</p> <p>Pull-down (default) = PHY Address 0 is set as a broadcast PHY address</p> <p>At the de-assertion of reset, this pin value is latched by the chip.</p>								
21	NAND_Tree#	lpu/Opu	<p>NAND tree mode</p> <p>Pull-up (default) = Disable</p> <p>Pull-down = Enable</p> <p>At the de-assertion of reset, this pin value is latched by the chip.</p>								

The strap-in pins are latched at the de-assertion of reset. In some systems, the MAC RMII receive input pins may drive high/low during power-up or reset, and consequently cause the PHY strap-in pins on the RMII signals to be latched to unintended high/low states. In this case, external pull-ups (4.7kΩ) or pull-downs (1.0kΩ) should be added on these PHY strap-in pins to ensure that the intended values are strapped-in correctly.

Functional Description: 10Base-T/100Base-TX Transceiver

The KSZ8091 is an integrated single 3.3V supply Fast Ethernet transceiver. It is fully compliant with the IEEE 802.3 Specification, and reduces board cost and simplifies board layout by using on-chip termination resistors for the two differential pairs and by integrating the regulator to supply the 1.2V core.

On the copper media side, the KSZ8091 supports 10Base-T and 100Base-TX for transmission and reception of data over a standard CAT-5 unshielded twisted pair (UTP) cable, and HP Auto MDI/MDI-X for reliable detection of and correction for straight-through and crossover cables.

On the MAC processor side, the KSZ8091MNX offers the Media Independent Interface (MII) and the KSZ8091RNB offers the Reduced Media Independent Interface (RMII) for direct connection with MII and RMII compliant Ethernet MAC processors and switches, respectively.

The MII management bus option gives the MAC processor complete access to the KSZ8091 control and status registers. Additionally, an interrupt pin eliminates the need for the processor to poll for PHY status change.

The KSZ8091MNX/RNB is used to refer to both KSZ8091MNX and KSZ8091RNB versions in this datasheet.

100Base-TX Transmit

The 100Base-TX transmit function performs parallel-to-serial conversion, 4B/5B encoding, scrambling, NRZ-to-NRZI conversion, and MLT3 encoding and transmission.

The circuitry starts with a parallel-to-serial conversion, which converts the MII/RMII data from the MAC into a 125MHz serial bit stream. The data and control stream is then converted into 4B/5B coding and followed by a scrambler. The serialized data is further converted from NRZ-to-NRZI format, and then transmitted in MLT3 current output. The output current is set by an external 6.49k Ω 1% resistor for the 1:1 transformer ratio.

The output signal has a typical rise/fall time of 4ns and complies with the ANSI TP-PMD standard regarding amplitude balance, overshoot, and timing jitter. The wave-shaped 10Base-T output is also incorporated into the 100Base-TX transmitter.

100Base-TX Receive

The 100Base-TX receiver function performs adaptive equalization, DC restoration, MLT3-to-NRZI conversion, data and clock recovery, NRZI-to-NRZ conversion, de-scrambling, 4B/5B decoding, and serial-to-parallel conversion.

The receiving side starts with the equalization filter to compensate for inter-symbol interference (ISI) over the twisted pair cable. Because the amplitude loss and phase distortion is a function of the cable length, the equalizer must adjust its characteristics to optimize performance. In this design, the variable equalizer makes an initial estimation based on comparisons of incoming signal strength against some known cable characteristics, then tunes itself for optimization. This is an ongoing process and self-adjusts against environmental changes such as temperature variations.

Next, the equalized signal goes through a DC-restoration and data-conversion block. The DC-restoration circuit compensates for the effect of baseline wander and improves the dynamic range. The differential data-conversion circuit converts MLT3 format back to NRZI. The slicing threshold is also adaptive.

The clock-recovery circuit extracts the 125MHz clock from the edges of the NRZI signal. This recovered clock is then used to convert the NRZI signal to NRZ format. This signal is sent through the de-scrambler, then the 4B/5B decoder. Finally, the NRZ serial data is converted to MII/RMII format and provided as the input data to the MAC.

Scrambler/De-Scrambler (100Base-TX Only)

The scrambler spreads the power spectrum of the transmitted signal to reduce electromagnetic interference (EMI) and baseline wander. The de-scrambler recovers the scrambled signal.

10Base-T Transmit

The 10Base-T drivers are incorporated with the 100Base-TX drivers to allow for transmission using the same magnetic. The drivers perform internal wave-shaping and pre-emphasis, and output 10Base-T signals with a typical amplitude of 2.5V peak for standard 10Base-T mode and 1.75V peak for energy-efficient 10Base-Te mode. The 10Base-T/10Base-Te signals have harmonic contents that are at least 27dB below the fundamental frequency when driven by an all-ones Manchester-encoded signal.

10Base-T Receive

On the receive side, input buffer and level detecting squelch circuits are used. A differential input receiver circuit and a phase-locked loop (PLL) performs the decoding function. The Manchester-encoded data stream is separated into clock signal and NRZ data. A squelch circuit rejects signals with levels less than 400mV, or with short pulse widths, to prevent noise at the RXP and RXM inputs from falsely triggering the decoder. When the input exceeds the squelch limit, the PLL locks onto the incoming signal and the KSZ8091MNX/RNB decodes a data frame. The receive clock is kept active during idle periods between data receptions.

SQE and Jabber Function (10Base-T Only)

In 10Base-T operation, a short pulse is put out on the COL pin after each frame is transmitted. This SQE test is needed to test the 10Base-T transmit/receive path. If transmit enable (TXEN) is high for more than 20ms (jabbering), the 10Base-T transmitter is disabled and COL is asserted high. If TXEN is then driven low for more than 250ms, the 10Base-T transmitter is re-enabled and COL is de-asserted (returns to low).

PLL Clock Synthesizer

The KSZ8091MNX/RNB generates all internal clocks and all external clocks for system timing from an external 25MHz crystal, oscillator, or reference clock. For the KSZ8091RNB in RMI 50MHz clock mode, these clocks are generated from an external 50MHz oscillator or system clock.

Auto-Negotiation

The KSZ8091MNX/RNB conforms to the auto-negotiation protocol, defined in Clause 28 of the IEEE 802.3 Specification.

Auto-negotiation allows unshielded twisted pair (UTP) link partners to select the highest common mode of operation.

During auto-negotiation, link partners advertise capabilities across the UTP link to each other and then compare their own capabilities with those they received from their link partners. The highest speed and duplex setting that is common to the two link partners is selected as the mode of operation.

The following list shows the speed and duplex operation mode from highest to lowest priority.

- Priority 1: 100Base-TX, full-duplex
- Priority 2: 100Base-TX, half-duplex
- Priority 3: 10Base-T, full-duplex
- Priority 4: 10Base-T, half-duplex

If auto-negotiation is not supported or the KSZ8091MNX/RNB link partner is forced to bypass auto-negotiation, then the KSZ8091MNX/RNB sets its operating mode by observing the signal at its receiver. This is known as parallel detection, which allows the KSZ8091MNX/RNB to establish a link by listening for a fixed signal protocol in the absence of the auto-negotiation advertisement protocol.

Auto-negotiation is enabled by either hardware pin strapping (NWAYEN, pin 30) or software (Register 0h, bit [12]).

By default, auto-negotiation is enabled after power-up or hardware reset. After that, auto-negotiation can be enabled or disabled by Register 0h, bit [12]. If auto-negotiation is disabled, the speed is set by Register 0h, bit [13], and the duplex is set by Register 0h, bit [8].

The auto-negotiation link-up process is shown in [Figure 1](#).

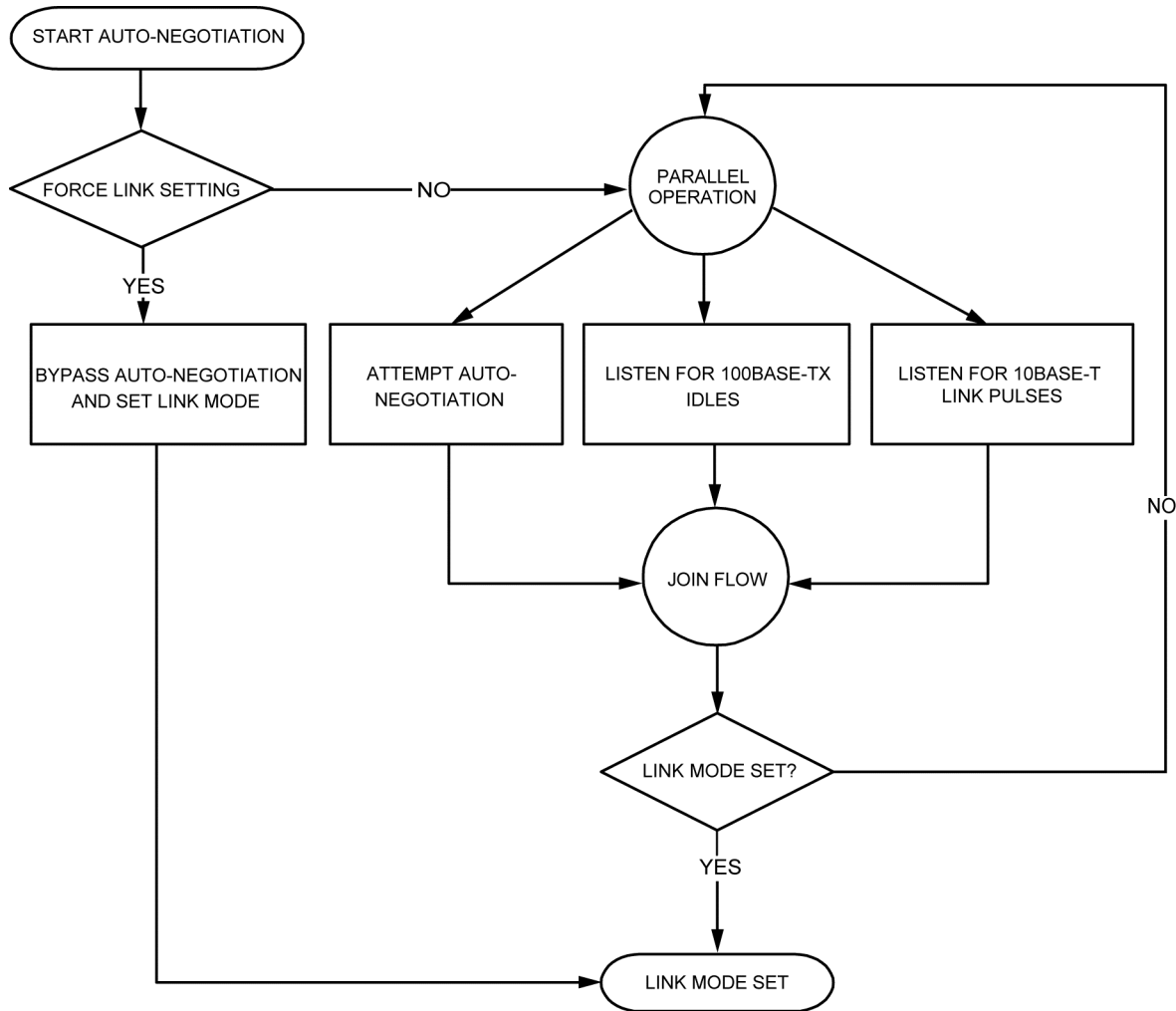

Figure 1. Auto-Negotiation Flow Chart

MII Data Interface (KSZ8091MNX only)

The Media Independent Interface (MII) is compliant with the IEEE 802.3 Specification. It provides a common interface between MII PHYs and MACs, and has the following key characteristics:

- Pin count is 16 pins (7 pins for data transmission, 7 pins for data reception, and 2 pins for carrier and collision indication).
- 10Mbps and 100Mbps data rates are supported at both half- and full-duplex.
- Data transmission and reception are independent and belong to separate signal groups.
- Transmit data and receive data are each 4 bits wide, a nibble.

By default, the KSZ8091MNX is configured to MII mode after it is powered up or hardware reset with the following:

- A 25MHz crystal connected to XI, XO (pins 9, 8), or an external 25MHz clock source (oscillator) connected to XI.
- The CONFIG[2:0] strapping pins (pins 18, 29, 28) set to 000 (default setting).

MII Signal Definition

[Table 1](#) describes the MII signals. Refer to Clause 22 of the IEEE 802.3 Specification for detailed information.

Table 1. MII Signal Definition

MII Signal Name	Direction (with respect to PHY, KSZ8091MNX signal)	Direction (with respect to MAC)	Description
TXC	Output	Input	Transmit Clock (2.5MHz for 10Mbps; 25MHz for 100Mbps)
TXEN	Input	Output	Transmit Enable
TXD[3:0]	Input	Output	Transmit Data[3:0]
TXER	Input	Output, or (not implemented)	Transmit Error (KSZ8091MNX implements only the EEE function for this pin. See " Transmit Error (TXER) " for details.)
RXC	Output	Input	Receive Clock (2.5MHz for 10Mbps; 25MHz for 100Mbps)
RXDV	Output	Input	Receive Data Valid
RXD[3:0]	Output	Input	Receive Data[3:0]
RXER	Output	Input, or (not required)	Receive Error
CRS	Output	Input	Carrier Sense
COL	Output	Input	Collision Detection

Transmit Clock (TXC)

TXC is sourced by the PHY. It is a continuous clock that provides the timing reference for TXEN, TXD[3:0] and TXER.

TXC is 2.5MHz for 10Mbps operation and 25MHz for 100Mbps operation.

Transmit Enable (TXEN)

TXEN indicates that the MAC is presenting nibbles on TXD[3:0] for transmission. It is asserted synchronously with the first nibble of the preamble and remains asserted while all nibbles to be transmitted are presented on the MII. It is negated before the first TXC following the final nibble of a frame.

TXEN transitions synchronously with respect to TXC.

Transmit Data[3:0] (TXD[3:0])

When TXEN is asserted, TXD[3:0] are the data nibbles presented by the MAC and accepted by the PHY for transmission.

When TXEN is de-asserted, the MAC drives TXD[3:0] to either 0000 for the idle state (non-EEE mode) or 0001 for the LPI state (EEE mode).

TXD[3:0] transitions synchronously with respect to TXC.

Transmit Error (TXER)

TXER is implemented only for the EEE function.

For EEE mode, this pin is driven by the EEE-MAC to put the KSZ8091MNX transmit into the LPI state.

For non-EEE mode, this pin is not defined for error transmission from MAC to KSZ8091MNX and can be left as a no connect.

TXER transitions synchronously with respect to TXC.

Receive Clock (RXC)

RXC provides the timing reference for RXDV, RXD[3:0] and RXER.

- In 10Mbps mode, RXC is recovered from the line while the carrier is active. When the line is idle or the link is down, RXC is derived from the PHY's reference clock.
- In 100Mbps mode, RXC is recovered continuously from the line. If the link is down, RXC is derived from the PHY's reference clock.

RXC is 2.5MHz for 10Mbps operation and 25MHz for 100Mbps operation.

Receive Data Valid (RXDV)

RXDV is driven by the PHY to indicate that the PHY is presenting recovered and decoded nibbles on RXD[3:0].

- In 10Mbps mode, RXDV is asserted with the first nibble of the start-of-frame delimiter (SFD), 5D, and remains asserted until the end of the frame.
- In 100Mbps mode, RXDV is asserted from the first nibble of the preamble to the last nibble of the frame.

RXDV transitions synchronously with respect to RXC.

Receive Data[3:0] (RXD[3:0])

For each clock period in which RXDV is asserted, RXD[3:0] transfers a nibble of recovered data from the PHY.

When RXDV is de-asserted, the PHY drives RXD[3:0] to either 0000 for the idle state (non-EEE mode) or 0001 for the LPI state (EEE mode).

RXD[3:0] transitions synchronously with respect to RXC.

Receive Error (RXER)

When RXDV is asserted, RXER is asserted for one or more RXC periods to indicate that a symbol error (for example, a coding error that a PHY can detect that may otherwise be undetectable by the MAC sub-layer) is detected somewhere in the frame that is being transferred from the PHY to the MAC.

In EEE mode only, when RXDV is de-asserted, RXER is driven by the PHY to inform the MAC that the KSZ8091MNX receive is in the LPI state.

RXER transitions synchronously with respect to RXC.

Carrier Sense (CRS)

CRS is asserted and de-asserted as follows:

- In 10Mbps mode, CRS assertion is based on the reception of valid preambles. CRS de-assertion is based on the reception of an end-of-frame (EOF) marker.
- In 100Mbps mode, CRS is asserted when a start-of-stream delimiter or /J/K symbol pair is detected. CRS is de-asserted when an end-of-stream delimiter or /T/R symbol pair is detected. Additionally, the PMA layer de-asserts CRS if IDLE symbols are received without /T/R.

Collision (COL)

COL is asserted in half-duplex mode whenever the transmitter and receiver are simultaneously active on the line. This informs the MAC that a collision has occurred during its transmission to the PHY.

COL transitions asynchronously with respect to TXC and RXC.

MII Signal Diagram

The KSZ8091MNX MII pin connections to the MAC are shown in [Figure 2](#).

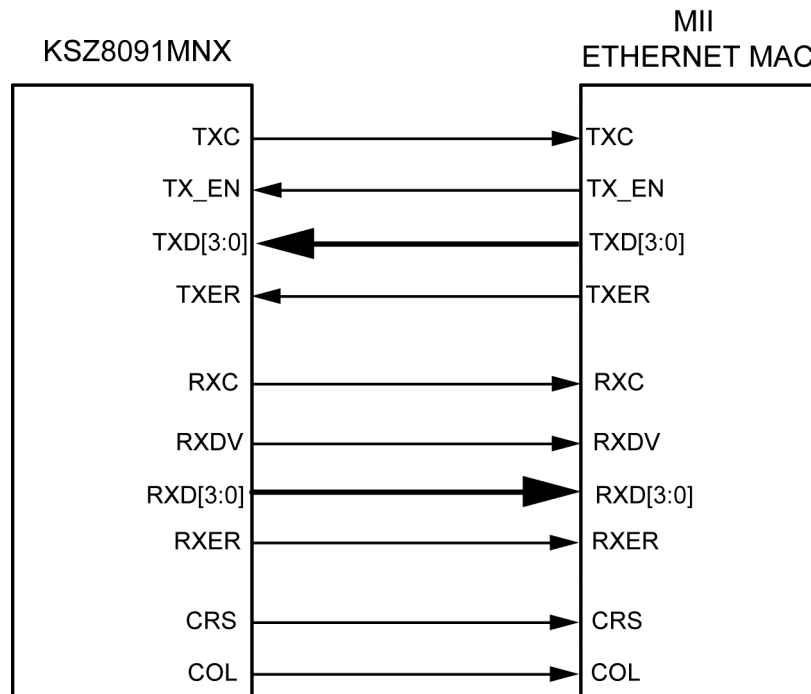

Figure 2. KSZ8091MNX MII Interface

RMII Data Interface (KSZ8091RNB only)

The Reduced Media Independent Interface (RMII) specifies a low pin count Media Independent Interface (MII). It provides a common interface between physical layer and MAC layer devices, and has the following key characteristics:

- Pin count is 8 pins (3 pins for data transmission, 4 pins for data reception, and 1 pin for the 50MHz reference clock).
- 10Mbps and 100Mbps data rates are supported at both half- and full-duplex.
- Data transmission and reception are independent and belong to separate signal groups.
- Transmit data and receive data are each 2 bits wide, a dibit.

RMII – 25MHz Clock Mode

The KSZ8091RNB is configured to RMII – 25MHz clock mode after it is powered up or hardware reset with the following:

- A 25MHz crystal connected to XI, XO (pins 9, 8), or an external 25MHz clock source (oscillator) connected to XI.
- The CONFIG[2:0] strapping pins (pins 18, 29, 28) set to 001.
- Register 1Fh, bit [7] is set to 0 (default value) to select 25MHz clock mode.

RMII – 50MHz Clock Mode

The KSZ8091RNB is configured to RMII – 50MHz clock mode after it is powered up or hardware reset with the following:

- An external 50MHz clock source (oscillator) connected to XI (pin 9).
- The CONFIG[2:0] strapping pins (pins 18, 29, 28) set to 001.
- Register 1Fh, bit [7] is set to 1 to select 50MHz clock mode.

RMII Signal Definition

Table 2 describes the RMII signals. Refer to RMII Specification v1.2 for detailed information.

Table 2. RMI Signal Definition

RMI Signal Name	Direction (with respect to PHY, KSZ8091RNB signal)	Direction (with respect to MAC)	Description
REF_CLK	Output (25MHz clock mode) / <no connect> (50MHz clock mode)	Input/ Input or <no connect>	Synchronous 50MHz reference clock for receive, transmit, and control interface
TXEN	Input	Output	Transmit Enable
TXD[1:0]	Input	Output	Transmit Data[1:0]
CRS_DV	Output	Input	Carrier Sense/Receive Data Valid
RXD[1:0]	Output	Input	Receive Data[1:0]
RXER	Output	Input, or (not required)	Receive Error

Reference Clock (REF_CLK)

REF_CLK is a continuous 50MHz clock that provides the timing reference for TXEN, TXD[1:0], CRS_DV, RXD[1:0] and RX_ER.

For 25MHz clock mode, the KSZ8091RNB generates and outputs the 50MHz RMI REF_CLK to the MAC at REF_CLK (pin 19).

For 50MHz clock mode, the KSZ8091RNB takes in the 50MHz RMI REF_CLK from the MAC or system board at XI (pin 9) and leaves the REF_CLK (pin 19) as a no connect.

Transmit Enable (TXEN)

TXEN indicates that the MAC is presenting dibits on TXD[1:0] for transmission. It is asserted synchronously with the first dibit of the preamble and remains asserted while all dibits to be transmitted are presented on the RMI. It is negated before the first REF_CLK following the final dibit of a frame.

TXEN transitions synchronously with respect to REF_CLK.

Transmit Data[1:0] (TXD[1:0])

When TXEN is asserted, TXD[1:0] are the data dibits presented by the MAC and accepted by the PHY for transmission.

When TXEN is de-asserted, the MAC drives TXD[1:0] to either 00 for the idle state (non-EEE mode) or 01 for the LPI state (EEE mode).

TXD[1:0] transitions synchronously with respect to REF_CLK.

Carrier Sense / Receive Data Valid (CRS_DV)

The PHY asserts CRS_DV when the receive medium is non-idle. It is asserted asynchronously when a carrier is detected. This happens when squelch is passed in 10Mbps mode, and when two non-contiguous 0s in 10 bits are detected in 100Mbps mode. Loss of carrier results in the de-assertion of CRS_DV.

While carrier detection criteria are met, CRS_DV remains asserted continuously from the first recovered dibit of the frame through the final recovered dibit. It is negated before the first REF_CLK that follows the final dibit. The data on RXD[1:0] is considered valid after CRS_DV is asserted. However, because the assertion of CRS_DV is asynchronous relative to REF_CLK, the data on RXD[1:0] is 00 until receive signals are properly decoded.

Receive Data[1:0] (RXD[1:0])

For each clock period in which CRS_DV is asserted, RXD[1:0] transfers a dibit of recovered data from the PHY.

When CRS_DV is de-asserted, the PHY drives RXD[1:0] to either 00 for the idle state (non-EEE mode) or 01 for the LPI state (EEE mode).

RXD[1:0] transitions synchronously with respect to REF_CLK.

Receive Error (RXER)

When CRS_DV is asserted, RXER is asserted for one or more REF_CLK periods to indicate that a symbol error (for example, a coding error that a PHY can detect that may otherwise be undetectable by the MAC sub-layer) is detected somewhere in the frame that is being transferred from the PHY to the MAC.

RXER transitions synchronously with respect to REF_CLK.

Collision Detection (COL)

The MAC regenerates the COL signal of the MII from TXEN and CRS_DV.

RMII Signal Diagram

The KSZ8091RNB RMII pin connections to the MAC for 25MHz clock mode are shown in Figure 3. The connections for 50MHz clock mode are shown in Figure 4.

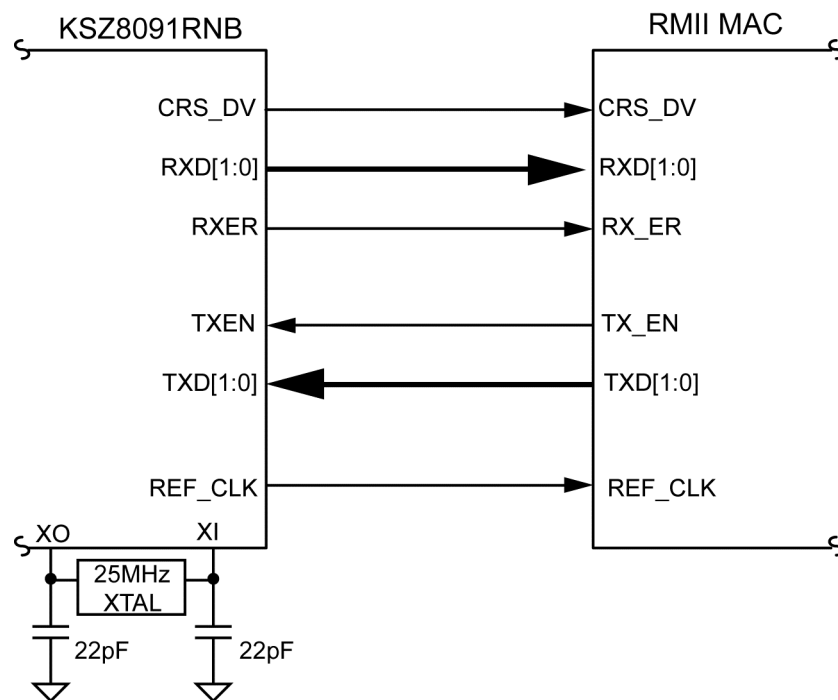

Figure 3. KSZ8091RNB RMII Interface (25MHz Clock Mode)

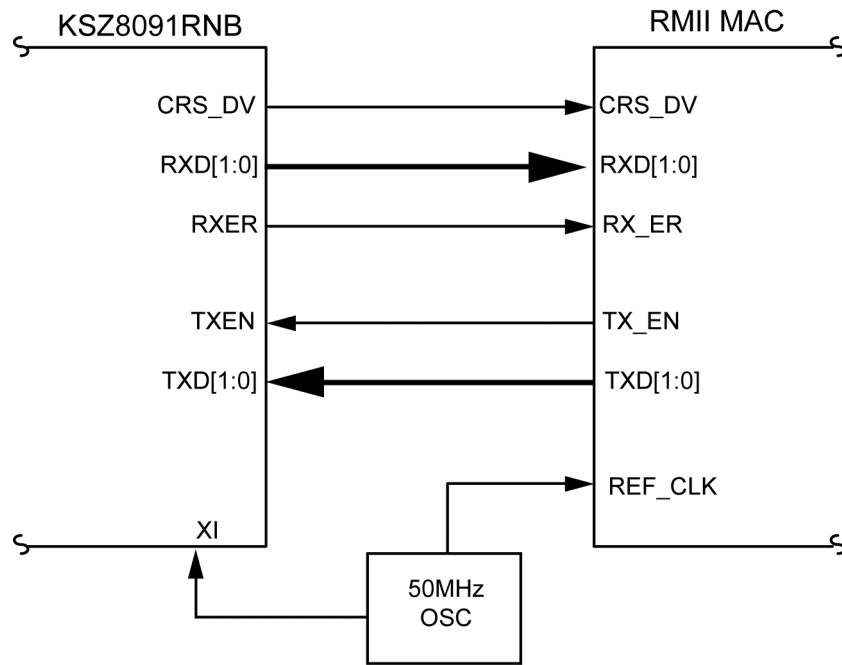

Figure 4. KSZ8091RNB RMI Interface (50MHz Clock Mode)

Back-to-Back Mode – 100Mbps Copper Repeater

Two KSZ8091MNX/RNB devices can be connected back-to-back to form a 100Base-TX copper repeater.

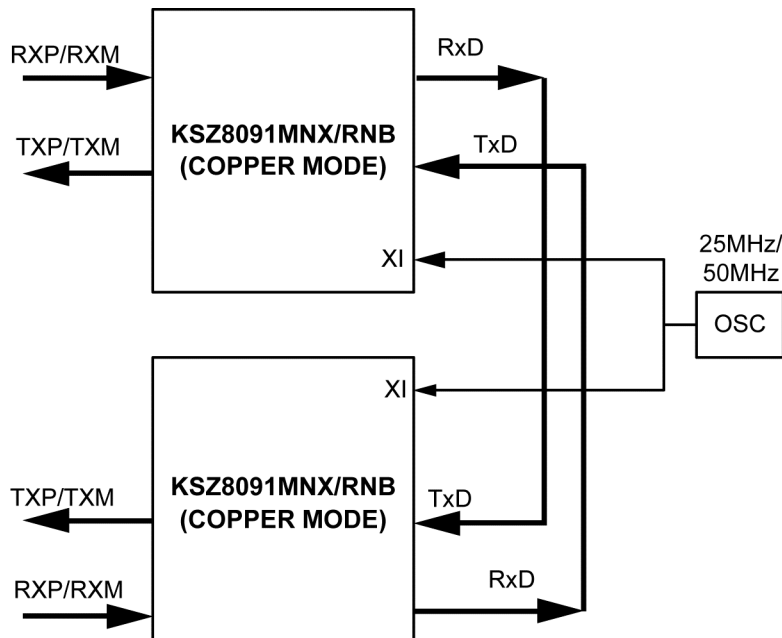

Figure 5. KSZ8091MNX/RNB to KSZ8091MNX/RNB Back-to-Back Copper Repeater

MII Back-to-Back Mode (KSZ8091MNX only)

In MII back-to-back mode, a KSZ8091MNX interfaces with another KSZ8091MNX to provide a complete 100Mbps copper repeater solution.

The KSZ8091MNX devices are configured to MII back-to-back mode after power-up or reset with the following:

- Strapping pin CONFIG[2:0] (pins 18, 29, 28) set to 110
- A common 25MHz reference clock connected to XI (pin 9) of both KSZ8091MNX devices
- MII signals connected as shown in [Table 3](#)

Table 3. MII Signal Connection for MII Back-to-Back Mode (100Base-TX Copper Repeater)

KSZ8091MNX (100Base-TX copper) [Device 1]			KSZ8091MNX (100Base-TX copper) [Device 2]		
Pin Name	Pin Number	Pin Type	Pin Name	Pin Number	Pin Type
RXC	19	Output	TXC	22	Input
RXDV	18	Output	TXEN	23	Input
RXD3	13	Output	TXD3	27	Input
RXD2	14	Output	TXD2	26	Input
RXD1	15	Output	TXD1	25	Input
RXD0	16	Output	TXD0	24	Input
TXC	22	Input	RXC	19	Output
TXEN	23	Input	RXDV	18	Output
TXD3	27	Input	RXD3	13	Output
TXD2	26	Input	RXD2	14	Output
TXD1	25	Input	RXD1	15	Output
TXD0	24	Input	RXD0	16	Output

RMII Back-to-Back Mode (KSZ8091RNB only)

In RMII back-to-back mode, a KSZ8091RNB interfaces with another KSZ8091RNB to provide a complete 100Mbps copper repeater solution.

The KSZ8091RNB devices are configured to RMII back-to-back mode after power-up or reset with the following:

- Strapping pin CONFIG[2:0] (pins 18, 29, 28) set to 101
- A common 50MHz reference clock connected to XI (pin 9) of both KSZ8091RNB devices
- RMII signals connected as shown in [Table 4](#)

Table 4. RMII Signal Connection for RMII Back-to-Back Mode (100Base-TX Copper Repeater)

KSZ8091RNB (100Base-TX copper) [Device 1]			KSZ8091RNB (100Base-TX copper) [Device 2]		
Pin Name	Pin Number	Pin Type	Pin Name	Pin Number	Pin Type
CRSDV	18	Output	TXEN	23	Input
RXD1	15	Output	TXD1	25	Input
RXD0	16	Output	TXD0	24	Input
TXEN	23	Input	CRSDV	18	Output
TXD1	25	Input	RXD1	15	Output
TXD0	24	Input	RXD0	16	Output

MII Management (MIIM) Interface

The KSZ8091MNX/RNB supports the IEEE 802.3 MII management interface, also known as the Management Data Input/Output (MDIO) interface. This interface allows an upper-layer device, such as a MAC processor, to monitor and control the state of the KSZ8091MNX/RNB. An external device with MIIM capability is used to read the PHY status and/or configure the PHY settings. More details about the MIIM interface can be found in Clause 22.2.4 of the IEEE 802.3 Specification.

The MIIM interface consists of the following:

- A physical connection that incorporates the clock line (MDC) and the data line (MDIO).
- A specific protocol that operates across the physical connection mentioned earlier, which allows the external controller to communicate with one or more PHY devices.
- A 32-register address space for direct access to IEEE-defined registers and vendor-specific registers, and for indirect access to MMD addresses and registers. See the “[Register Map](#)” section.

As the default, the KSZ8091MNX/RNB supports unique PHY addresses 1 to 7, and broadcast PHY address 0. The latter is defined in the IEEE 802.3 Specification, and can be used to read/write to a single KSZ8091MNX/RNB device, or write to multiple KSZ8091MNX/RNB devices simultaneously.

PHY address 0 can optionally be disabled as the broadcast address by either hardware pin strapping (B-CAST_OFF, pin 19) or software (Register 16h, bit [9]), and assigned as a unique PHY address.

The PHYAD[2:0] strapping pins are used to assign a unique PHY address between 0 and 7 to each KSZ8091MNX/RNB device.

[Table 5](#) shows the MII management frame format for the KSZ8091MNX/RNB.

Table 5. MII Management Frame Format for the KSZ8091MNX/RNB

	Preamble	Start of Frame	Read/Write OP Code	PHY Address Bits [4:0]	REG Address Bits [4:0]	TA	Data Bits [15:0]	Idle
Read	32 1's	01	10	00AAA	RRRRR	Z0	DDDDDDDD_DDDDDDDD	Z
Write	32 1's	01	01	00AAA	RRRRR	10	DDDDDDDD_DDDDDDDD	Z

Interrupt (INTRP)

INTRP (pin 21) is an optional interrupt signal that is used to inform the external controller that there has been a status update to the KSZ8091MNX/RNB PHY Register. Bits [15:8] of Register 1Bh are the interrupt control bits to enable and disable the conditions for asserting the INTRP signal. Bits [7:0] of Register 1Bh are the interrupt status bits to indicate which interrupt conditions have occurred. The interrupt status bits are cleared after reading Register 1Bh.

Bit [9] of Register 1Fh sets the interrupt level to active high or active low. The default is active low.

The MII management bus option gives the MAC processor complete access to the KSZ8091MNX/RNB control and status registers. Additionally, an interrupt pin eliminates the need for the processor to poll the PHY for status change.

HP Auto MDI/MDI-X

HP Auto MDI/MDI-X configuration eliminates the need to decide whether to use a straight cable or a crossover cable between the KSZ8091MNX/RNB and its link partner. This feature allows the KSZ8091MNX/RNB to use either type of cable to connect with a link partner that is in either MDI or MDI-X mode. The auto-sense function detects transmit and receive pairs from the link partner and assigns transmit and receive pairs to the KSZ8091MNX/RNB accordingly.

HP Auto MDI/MDI-X is enabled by default. It is disabled by writing a '1' to Register 1Fh, bit [13]. MDI and MDI-X mode is selected by Register 1Fh, bit [14] if HP Auto MDI/MDI-X is disabled.

An isolation transformer with symmetrical transmit and receive data paths is recommended to support Auto MDI/MDI-X.

[Table 6](#) shows how the IEEE 802.3 Standard defines MDI and MDI-X.

Table 6. MDI/MDI-X Pin Definition

MDI		MDI-X	
RJ-45 Pin	Signal	RJ-45 Pin	Signal
1	TX+	1	RX+
2	TX-	2	RX-
3	RX+	3	TX+
6	RX-	6	TX-

Straight Cable

A straight cable connects an MDI device to an MDI-X device, or an MDI-X device to an MDI device. [Figure 6](#) shows a typical straight cable connection between a NIC card (MDI device) and a switch or hub (MDI-X device).

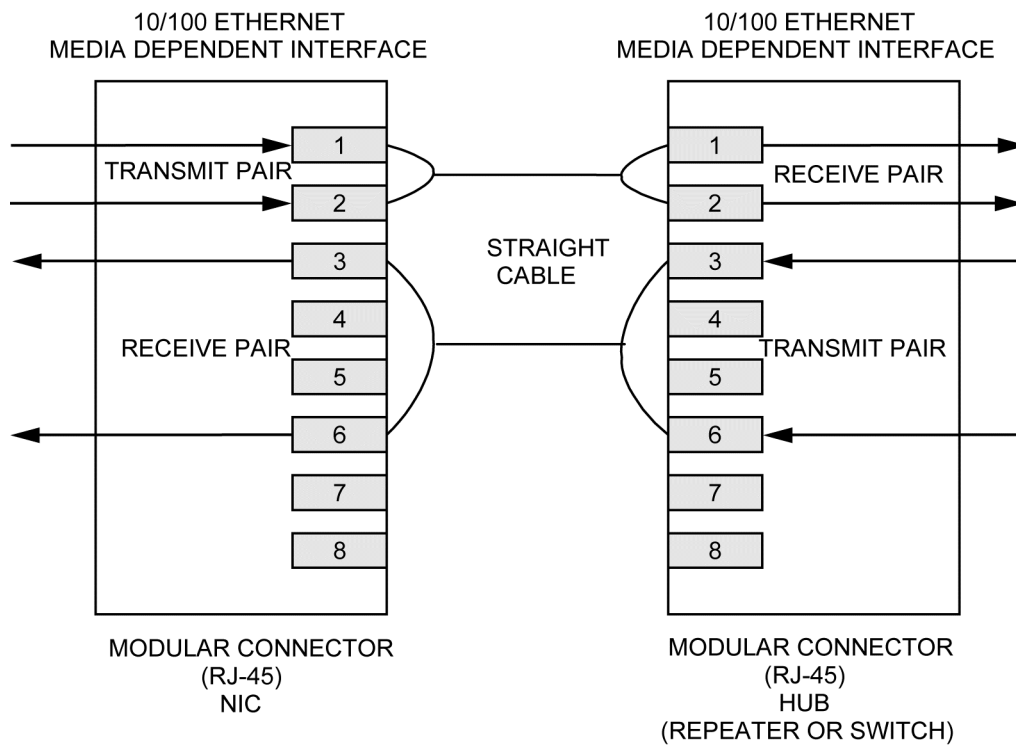

Figure 6. Typical Straight Cable Connection

Crossover Cable

A crossover cable connects an MDI device to another MDI device, or an MDI-X device to another MDI-X device. [Figure 7](#) shows a typical crossover cable connection between two switches or hubs (two MDI-X devices).

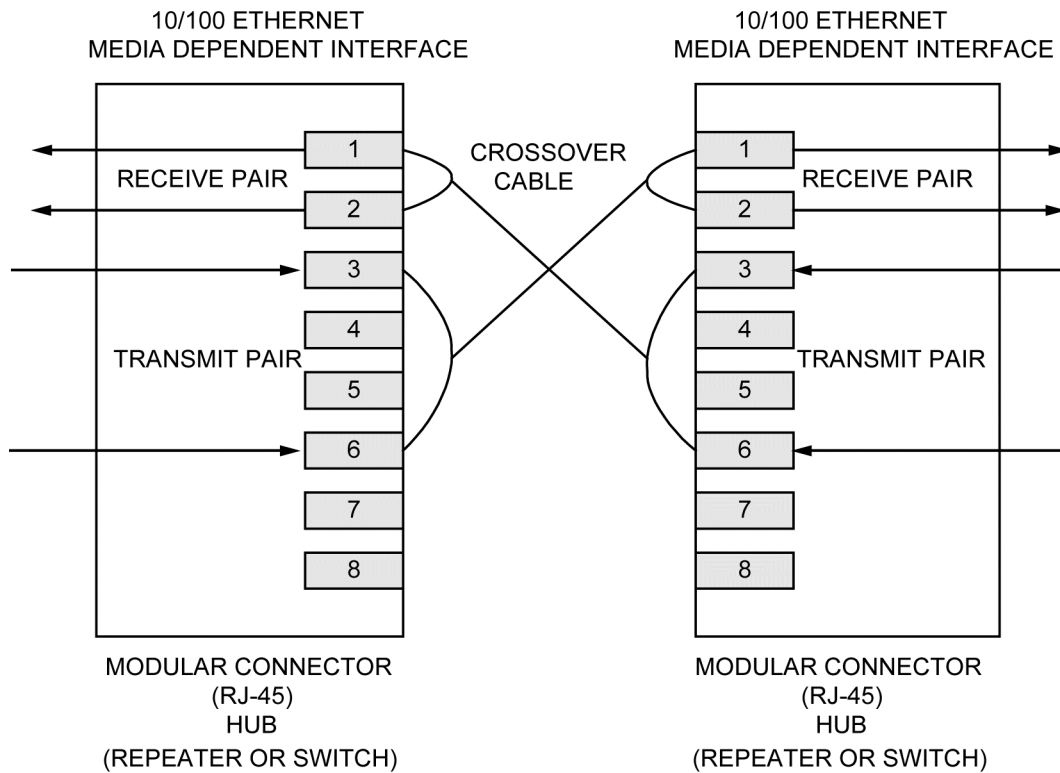

Figure 7. Typical Crossover Cable Connection

Loopback Mode

The KSZ8091MNX/RNB supports the following loopback operations to verify analog and/or digital data paths.

- Local (digital) loopback
- Remote (analog) loopback

Local (Digital) Loopback

This loopback mode checks the MII/RMII transmit and receive data paths between the KSZ8091MNX/RNB and the external MAC, and is supported for both speeds (10/100Mbps) at full-duplex.

The loopback data path is shown in [Figure 8](#).

1. The MII/RMII MAC transmits frames to the KSZ8091MNX/RNB.
2. Frames are wrapped around inside the KSZ8091MNX/RNB.
3. The KSZ8091MNX/RNB transmits frames back to the MII/RMII MAC.

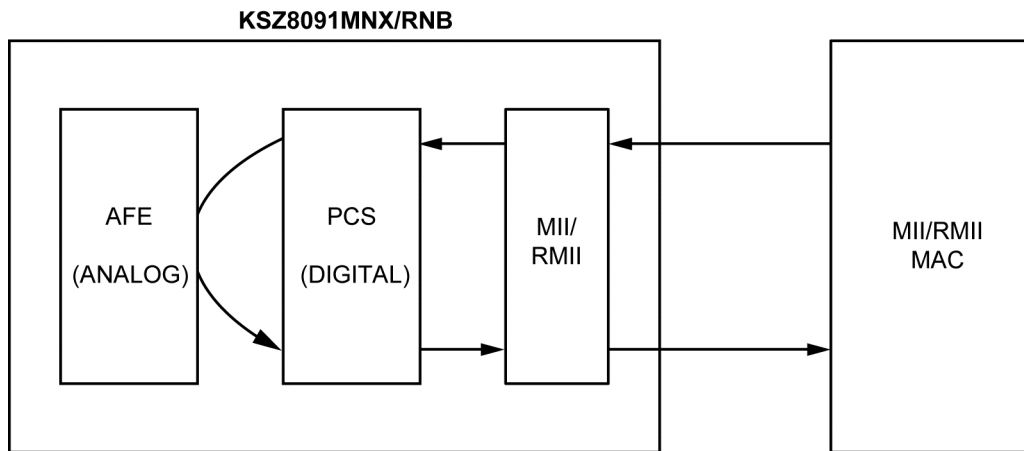

Figure 8. Local (Digital) Loopback

The following programming action and register settings are used for local loopback mode.

For 10/100Mbps loopback,

Set Register 0h,

- Bit [14] = 1 // Enable local loopback mode
- Bit [13] = 0/1 // Select 10Mbps/100Mbps speed
- Bit [12] = 0 // Disable auto-negotiation
- Bit [8] = 1 // Select full-duplex mode

Remote (Analog) Loopback

This loopback mode checks the line (differential pairs, transformer, RJ-45 connector, Ethernet cable) transmit and receive data paths between the KSZ8091MNX/RNB and its link partner, and is supported for 100Base-TX full-duplex mode only.

The loopback data path is shown in [Figure 9](#).

1. The Fast Ethernet (100Base-TX) PHY link partner transmits frames to the KSZ8091MNX/RNB.
2. Frames are wrapped around inside the KSZ8091MNX/RNB.
3. The KSZ8091MNX/RNB transmits frames back to the Fast Ethernet (100Base-TX) PHY link partner.

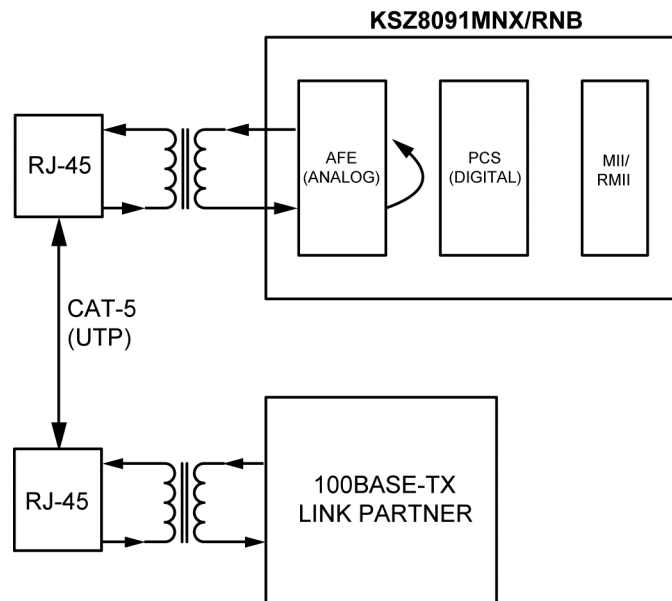

Figure 9. Remote (Analog) Loopback

The following programming steps and register settings are used for remote loopback mode.

1. Set Register 0h,
 - Bits [13] = 1 // Select 100Mbps speed
 - Bit [12] = 0 // Disable auto-negotiation
 - Bit [8] = 1 // Select full-duplex mode
 Or just auto-negotiate and link up with the link partner at 100Base-TX full-duplex mode.
2. Set Register 1Fh,
 - Bit [2] = 1 // Enable remote loopback mode

LinkMD[®] Cable Diagnostic

The LinkMD function uses time-domain reflectometry (TDR) to analyze the cabling plant for common cabling problems. These include open circuits, short circuits, and impedance mismatches.

LinkMD works by sending a pulse of known amplitude and duration down the MDI or MDI-X pair, then analyzing the shape of the reflected signal to determine the type of fault. The time duration for the reflected signal to return provides the approximate distance to the cabling fault. The LinkMD function processes this TDR information and presents it as a numerical value that can be translated to a cable distance.

LinkMD is initiated by accessing register 1Dh, the LinkMD Cable Diagnostic register, in conjunction with Register 1Fh, the PHY Control 2 Register. The latter register is used to disable Auto MDI/MDI-X and to select either MDI or MDI-X as the cable differential pair for testing.

NAND Tree Support

The KSZ8091MNX/RNB provides parametric NAND tree support for fault detection between chip I/Os and board. The NAND tree is a chain of nested NAND gates in which each KSZ8091MNX/RNB digital I/O (NAND tree input) pin is an input to one NAND gate along the chain. At the end of the chain, the CRS/CONFIG1 pin provides the output for the nested NAND gates.

The NAND tree test process includes:

- Enabling NAND tree mode
- Pulling all NAND tree input pins high
- Driving each NAND tree input pin low, sequentially, according to the NAND tree pin order
- Checking the NAND tree output to make sure there is a toggle high-to-low or low-to-high for each NAND tree input driven low

Table 7 and Table 8 list the NAND tree pin orders for KSZ8091MNX and KSZ8091RNB, respectively.

Table 7. NAND Tree Test Pin Order for KSZ8091MNX

Pin Number	Pin Name	NAND Tree Description
11	MDIO	Input
12	MDC	Input
13	RXD3	Input
14	RXD2	Input
15	RXD1	Input
16	RXD0	Input
18	RXDV	Input
19	RXC	Input
20	RXER	Input
21	INTRP	Input
22	TXC	Input
23	TXEN	Input
24	TXD0	Input
25	TXD1	Input
26	TXD2	Input
27	TXD3	Input
30	LED0	Input
28	COL	Input
29	CRS	Output

Table 8. NAND Tree Test Pin Order for KSZ8091RNB

Pin Number	Pin Name	NAND Tree Description
11	MDIO	Input
12	MDC	Input
13	PHYAD0	Input
14	PHYAD1	Input
15	RXD1	Input
16	RXD0	Input
18	CRS_DV	Input
19	REF_CLK	Input
20	RXER	Input
21	INTRP	Input
22	PME_EN	Input
23	TXEN	Input
24	TXD0	Input
25	TXD1	Input
30	LED0	Input
31	LED1	Input
28	CONFIG0	Input
29	CONFIG1	Output

NAND Tree I/O Testing

Use the following procedure to check for faults on the KSZ8091MNX/RNB digital I/O pin connections to the board:

1. Enable NAND tree mode using either hardware (NAND_Tree#, pin 21) or software (Register 16h, bit [5]).
2. Use board logic to drive all KSZ8091MNX/RNB NAND tree input pins high.
3. Use board logic to drive each NAND tree input pin, in KSZ8091MNX/RNB NAND tree pin order, as follows:
 - a. Toggle the first pin (MDIO) from high to low, and verify that the CRS/CONFIG1 pin switches from high to low to indicate that the first pin is connected properly.
 - b. Leave the first pin (MDIO) low.
 - c. Toggle the second pin (MDC) from high to low, and verify that the CRS/CONFIG1 pin switches from low to high to indicate that the second pin is connected properly.
 - d. Leave the first pin (MDIO) and the second pin (MDC) low.
 - e. Toggle the third pin (RXD3/PHYAD0) from high to low, and verify that the CRS/CONFIG1 pin switches from high to low to indicate that the third pin is connected properly.
 - f. Continue with this sequence until all KSZ8091MNX/RNB NAND tree input pins have been toggled.

Each KSZ8091MNX/RNB NAND tree input pin must cause the CRS/CONFIG1 output pin to toggle high-to-low or low-to-high to indicate a good connection. If the CRS/CONFIG1 pin fails to toggle when the KSZ8091MNX/RNB input pin toggles from high to low, the input pin has a fault.

Power Management

The KSZ8091MNX/RNB incorporates a number of power-management modes and features that provide methods to consume less energy. These are discussed in the following sections.

Power-Saving Mode

Power-saving mode is used to reduce the transceiver power consumption when the cable is unplugged. It is enabled by writing a '1' to Register 1Fh, bit [10], and is in effect when auto-negotiation mode is enabled and the cable is disconnected (no link).

In this mode, the KSZ8091MNX/RNB shuts down all transceiver blocks, except for the transmitter, energy detect, and PLL circuits.

By default, power-saving mode is disabled after power-up.

Energy-Detect Power-Down Mode

Energy-detect power-down (EDPD) mode is used to further reduce transceiver power consumption when the cable is unplugged. It is enabled by writing a '0' to Register 18h, bit [11], and is in effect when auto-negotiation mode is enabled and the cable is disconnected (no link).

EDPD mode works with the PLL off (set by writing a '1' to Register 10h, bit [4] to automatically turn the PLL off in EDPD mode) to turn off all KSZ8091MNX/RNB transceiver blocks except the transmitter and energy-detect circuits.

Power can be reduced further by extending the time interval between transmissions of link pulses to check for the presence of a link partner. The periodic transmission of link pulses is needed to ensure the KSZ8091MNX/RNB and its link partner, when operating in the same low-power state and with Auto MDI/MDI-X disabled, can wake up when the cable is connected between them.

By default, energy-detect power-down mode is disabled after power-up.

Power-Down Mode

Power-down mode is used to power down the KSZ8091MNX/RNB device when it is not in use after power-up. It is enabled by writing a '1' to Register 0h, bit [11].

In this mode, the KSZ8091MNX/RNB disables all internal functions except the MII management interface. The KSZ8091MNX/RNB exits (disables) power-down mode after Register 0h, bit [11] is set back to '0'.

Slow-Oscillator Mode

Slow-oscillator mode is used to disconnect the input reference crystal/clock on XI (pin 9) and select the on-chip slow oscillator when the KSZ8091MNX/RNB device is not in use after power-up. It is enabled by writing a '1' to Register 11h, bit [5].

Slow-oscillator mode works in conjunction with power-down mode to put the KSZ8091MNX/RNB device in the lowest power state, with all internal functions disabled except the MII management interface. To properly exit this mode and return to normal PHY operation, use the following programming sequence:

1. Disable slow-oscillator mode by writing a '0' to Register 11h, bit [5].
2. Disable power-down mode by writing a '0' to Register 0h, bit [11].
3. Initiate software reset by writing a '1' to Register 0h, bit [15].

Energy Efficient Ethernet (EEE)

The KSZ8091MNX implements Energy Efficient Ethernet (EEE) for the Media Independent Interface (MII) as described in IEEE Standard 802.3az. The Standard is defined around an EEE-compliant MAC on the host side and an EEE-compliant link partner on the line side that support special signaling associated with EEE. EEE saves power by keeping the AC signal on the copper Ethernet cable at approximately 0V peak-to-peak as often as possible during periods of no traffic activity, while maintaining the link-up status. This is referred to as low-power idle (LPI) mode or state.

Similarly, the KSZ8091RNB implements EEE for the Reduced Media Independent Interface (RMII) as described in IEEE Standard 802.3az for line signaling by the two differential pairs (analog side) and according to the multisource agreement (MSA) of collaborating Fast Ethernet chip vendors for the RMII (digital side). This agreement is based on the IEEE Standard's EEE implementation for MII (100Mbps).

During LPI mode, the copper link responds automatically when it receives traffic and resumes normal PHY operation immediately, without blockage of traffic or loss of packet. This involves exiting LPI mode and returning to normal 100Mbps operating mode. Wake-up time is <math><30\mu\text{s}</math> for 100Base-TX.

The LPI state is controlled independently for transmit and receive paths, allowing the LPI state to be active (enabled) for:

- Transmit cable path only
- Receive cable path only
- Both transmit and receive cable paths

The KSZ8091MNX/RNB has the EEE function disabled as the power-up default setting. To enable the EEE function for 100Mbps mode, use the following programming sequence:

1. Enable 100Mbps EEE mode advertisement by writing a '1' to MMD address 7h, Register 3Ch, bit [1].
2. Restart auto-negotiation by writing a '1' to standard Register 0h, bit [9].

For standard (non-EEE) 10Base-T mode, normal link pulses (NLPs) with long periods of no AC signal transmission are used to maintain the link during the idle period when there is no traffic activity. To save more power, the KSZ8091MNX/RNB provides the option to enable 10Base-Te mode, which saves additional power by reducing the transmitted signal amplitude from 2.5V to 1.75V. To enable 10Base-Te mode, write a '1' to standard Register 13h, bit [4].

During LPI mode, refresh transmissions are used to maintain the link; power savings occur in quiet periods. Approximately every 20 to 22 milliseconds, a refresh transmission of 200 to 220 microseconds is sent to the link partner. The refresh transmissions and quiet periods are shown in [Figure 10](#).

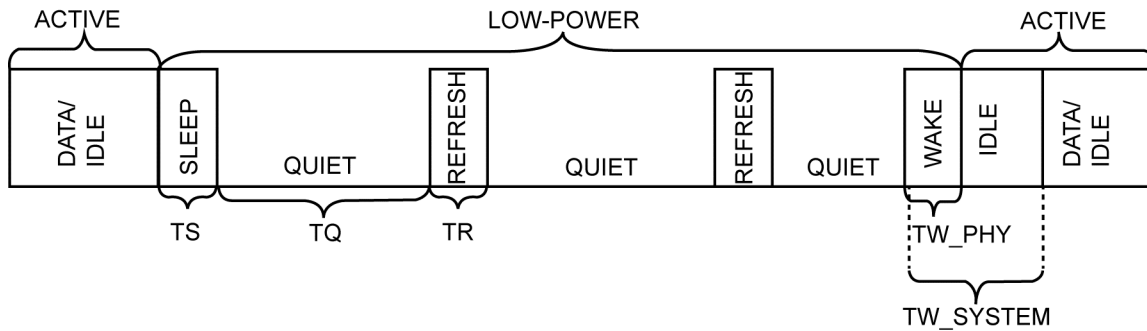

Figure 10. LPI Mode (Refresh Transmissions and Quiet Periods)

Transmit Direction Control (MAC-to-PHY)

The KSZ8091MNX enters LPI mode for the transmit direction when its attached EEE-compliant MII MAC de-asserts TXEN, asserts TXER, and sets TXD[3:0] to 0001. The KSZ8091MNX remains in the LPI transmit state while the MAC maintains the states of these signals. When the MAC changes any of the TXEN, TXER, or TX data signals from their LPI state values, the KSZ8091MNX exits the LPI transmit state.

The TXC clock is not stopped, because it is sourced from the PHY and is used by the MAC for MII transmit.

Figure 11 shows the LPI transition for MII (100Mbps) transmit.

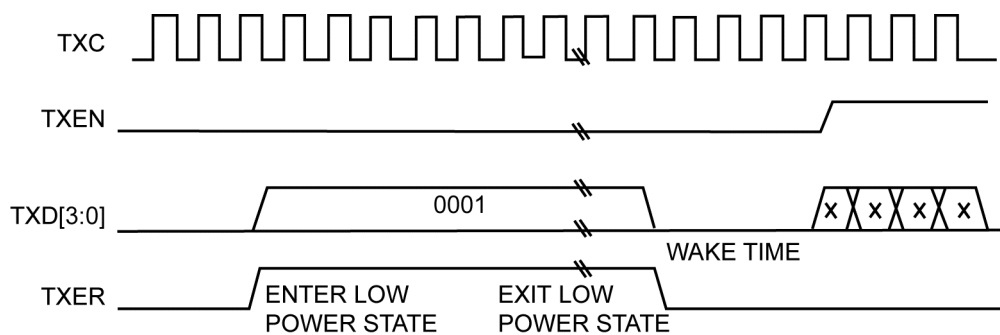

Figure 11. LPI Transition – MII (100Mbps) Transmit

Similarly, the KSZ8091RNB enters LPI mode for the transmit direction when its attached IEEE-compliant RMII MAC de-asserts TXEN and sets TXD[1:0] to 01. The KSZ8091RNB remains in the LPI transmit state while the RMII MAC maintains the states of these signals. When the RMII MAC changes any of the TXEN or TX data signals from their LPI state values, the KSZ8091RNB exits the LPI transmit state.

Figure 12 shows the LPI transition for RMII (100Mbps) transmit.

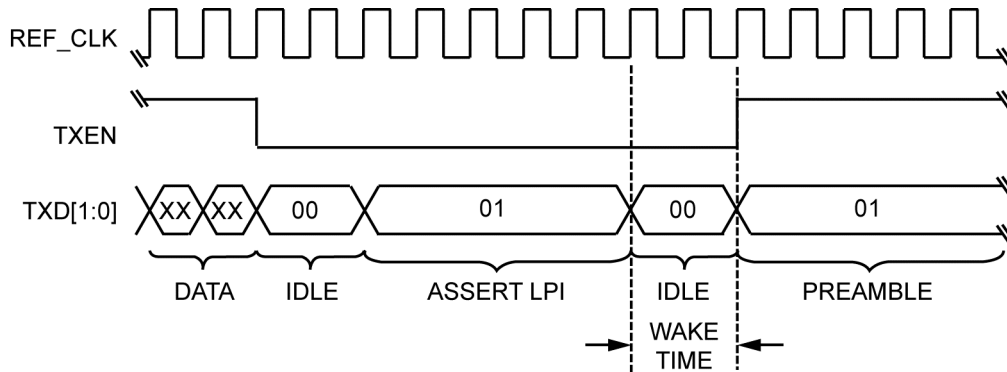

Figure 12. LPI Transition – RMII (100Mbps) Transmit

Receive Direction Control (PHY-to-MAC)

The KSZ8091MNX enters LPI mode for the receive direction when it receives the /P/ code bit pattern (Sleep/Refresh) from its IEEE-compliant link partner. It then de-asserts RXDV, asserts RXER, and drives RXD[3:0] to 0001. The KSZ8091MNX remains in the LPI receive state while it continues to receive the refresh from its link partner, so it will continue to maintain and drive the LPI output states for the MII receive signals to inform the attached IEEE-compliant MII MAC that it is in the LPI receive state. When the KSZ8091MNX receives a non /P/ code bit pattern (non-refresh), it exits the LPI receive state and sets the RXDV, RXER, and RX data signals to set a normal frame or normal idle.

The KSZ8091MNX stops the RXC clock output to the MAC after nine or more RXC clock cycles have occurred in the LPI receive state, to save more power. By default, RXC clock stoppage is enabled. It is disabled by writing a '0' to MMD address 3h, Register 0h, bit [10].

Figure 13 shows the LPI transition for MII (100Mbps) receive.

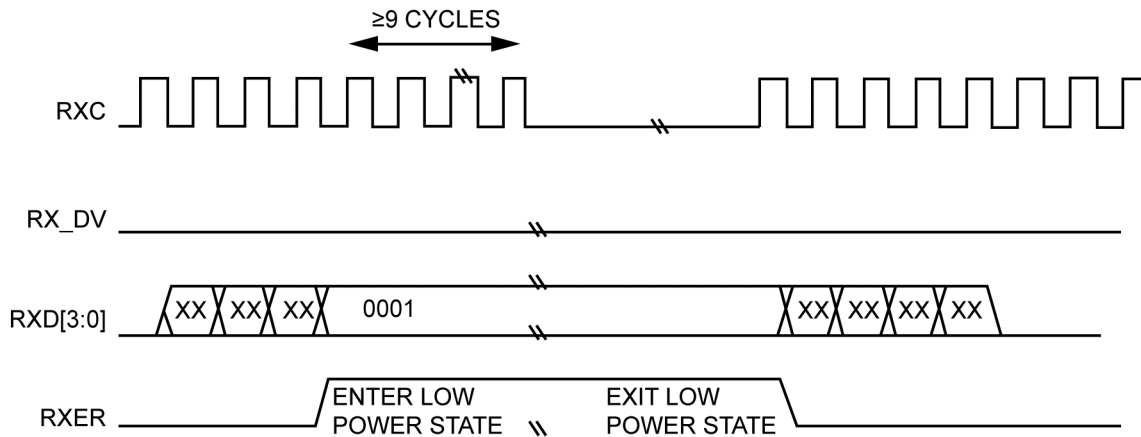

Figure 13. LPI Transition – MII (100Mbps) Receive

Similarly, the KSZ8091RNB enters LPI mode for the receive direction when it receives the /P/ code bit pattern (Sleep/Refresh) from its EEE-compliant link partner. It then de-asserts CRS_DV and drives RXD[1:0] to 01. The KSZ8091RNB remains in the LPI receive state while it continues to receive the refresh from its link partner, so it will continue to maintain and drive the LPI output states for the RMII receive signals to inform the attached EEE-compliant RMII MAC that it is in the LPI receive state. When the KSZ8091RNB receives a non /P/ code bit pattern (non-refresh), it exits the LPI receive state and sets the CRS_DV and RX data signals to set a normal frame or normal idle.

Figure 14 shows the LPI transition for RMII (100Mbps) receive.

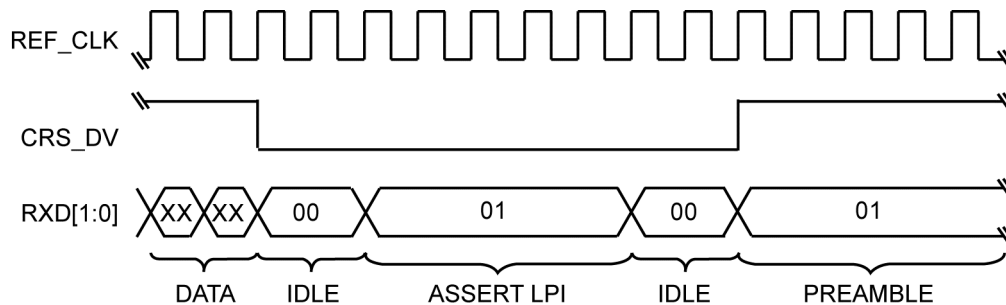

Figure 14. LPI Transition – RMII (100Mbps) Receive

Registers Associated with EEE

The following registers are provided for EEE configuration and management:

- Standard Register 13h - AFE Control 4 (to enable 10Base-T_e mode)
- MMD address 1h, Register 0h - PMA/PMD Control 1 (to enable LPI)
- MMD address 1h, Register 1h - PMA/PMD Status 1 (for LPI status)
- MMD address 3h, Register 0h - EEE PCS Control 1 (to stop RXC clock for KSZ8091MNX only)
- MMD address 7h, Register 3Ch - EEE Advertisement
- MMD address 7h, Register 3Dh - EEE Link Partner Advertisement

Wake-On-LAN

Wake-On-LAN (WOL) is normally a MAC-based function to wake up a host system (for example, an Ethernet end device, such as a PC) that is in standby power mode. Wake-up is triggered by receiving and detecting a special packet (commonly referred to as the “magic packet”) that is sent by the remote link partner. The KSZ8091MNX/RNB can perform the same WOL function if the MAC address of its associated MAC device is entered into the KSZ8091MNX/RNB PHY registers for magic-packet detection. When the KSZ8091MNX/RNB detects the magic packet, it wakes up the host by driving its power management event (PME) output pin low.

By default, the WOL function is disabled. It is enabled by setting the enabling bit and configuring the associated registers for the selected PME wake-up detection method.

The KSZ8091MNX/RNB provides three methods to trigger a PME wake-up:

- Magic-packet detection
- Customized-packet detection
- Link status change detection

Magic-Packet Detection

The magic packet’s frame format starts with 6 bytes of 0xFFh and is followed by 16 repetitions of the MAC address of its associated MAC device (local MAC device).

When the magic packet is detected from its link partner, the KSZ8091MNX/RNB asserts its PME output pin low.

The following MMD address 1Fh registers are provided for magic-packet detection:

- Magic-packet detection is enabled by writing a '1' to MMD address 1Fh, Register 0h, bit [6]
- The MAC address (for the local MAC device) is written to and stored in MMD address 1Fh, Registers 19h – 1Bh

The KSZ8091MNX/RNB does not generate the magic packet. The magic packet must be provided by the external system.

Customized-Packet Detection

The customized packet has associated register/bit masks to select which byte, or bytes, of the first 64 bytes of the packet to use in the CRC calculation. After the KSZ8091MNX/RNB receives the packet from its link partner, the selected bytes for the received packet are used to calculate the CRC. The calculated CRC is compared to the expected CRC value that was previously written to and stored in the KSZ8091MNX/RNB PHY Registers. If there is a match, the KSZ8091MNX/RNB asserts its PME output pin low.

Four customized packets are provided to support four types of wake-up scenarios. A dedicated set of registers is used to configure and enable each customized packet.

The following MMD Registers are provided for customized-packet detection:

- Each of the four customized packets is enabled via MMD address 1Fh, Register 0h,
 - Bit [2] // For customized packets, type 0
 - Bit [3] // For customized packets, type 1
 - Bit [4] // For customized packets, type 2
 - Bit [5] // For customized packets, type 3
- Masks to indicate which of the first 64-bytes to use in the CRC calculation are set in:
 - MMD address 1Fh, Registers 1h – 4h // For customized packets, type 0
 - MMD address 1Fh, Registers 7h – Ah // For customized packets, type 1
 - MMD address 1Fh, Registers Dh – 10h // For customized packets, type 2
 - MMD address 1Fh, Registers 13h – 16h // For customized packets, type 3
- 32-bit expected CRCs are written to and stored in:
 - MMD address 1Fh, Registers 5h – 6h // For customized packets, type 0
 - MMD address 1Fh, Registers Bh – Ch // For customized packets, type 1
 - MMD address 1Fh, Registers 11h – 12h // For customized packets, type 2
 - MMD address 1Fh, Registers 17h – 18h // For customized packets, type 3

Link Status Change Detection

If link status change detection is enabled, the KSZ8091MNX/RNB asserts its PME output pin low whenever there is a link status change, using the following MMD address 1Fh register bits and their enabled (1) or disabled (0) settings:

- MMD address 1Fh, Register 0h, bit [0] // For link-up detection
- MMD address 1Fh, Register 0h, bit [1] // For link-down detection

The PME output signal is available on either INTRP/PME_N2 (pin 21) or LED0/PME_N1 (pin 30), and is enabled using standard Register 16h, bit [15]. MMD address 1Fh, Register 0h, bits [15:14] defines and selects the output functions for pins 21 and 30.

The PME output is active low and requires a 1k Ω pull-up to the VDDIO supply. When asserted, the PME output is cleared by disabling the register bit that enabled the PME trigger source (magic packet, customized packet, link status change).

Reference Circuit for Power and Ground Connections

The KSZ8091MNX/RNB is a single 3.3V supply device with a built-in regulator to supply the 1.2V core. The power and ground connections are shown in Figure 15 and Table 9 for 3.3V VDDIO.

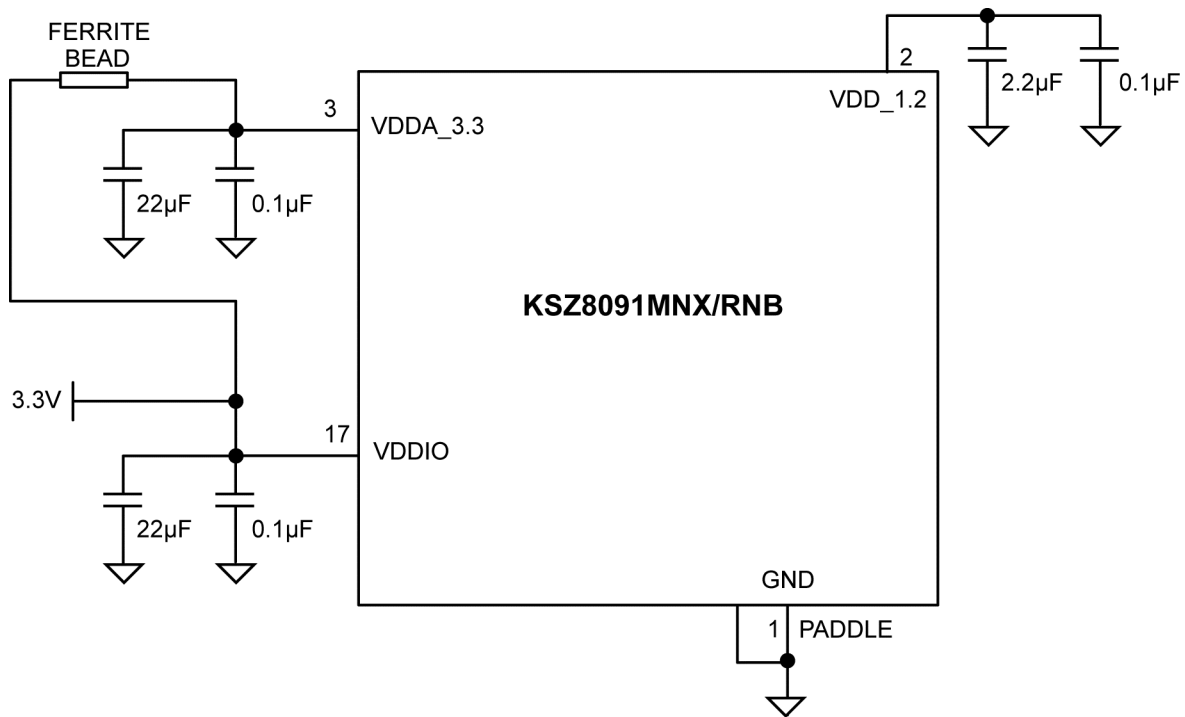

Figure 15. KSZ8091MNX/RNB Power and Ground Connections

Table 9. KSZ8091MNX/RNB Power Pin Description

Power Pin	Pin Number	Description
VDD_1.2	2	Decouple with 2.2µF and 0.1µF capacitors to ground.
VDDA_3.3	3	Connect to board's 3.3V supply through a ferrite bead. Decouple with 22µF and 0.1µF capacitors to ground.
VDDIO	17	Connect to board's 3.3V supply for 3.3V VDDIO. Decouple with 22µF and 0.1µF capacitors to ground.

Typical Current/Power Consumption

Table 10 through Table 12 show typical values for current consumption by the transceiver (VDDA_3.3) and digital I/O (VDDIO) power pins, and typical values for power consumption by the KSZ8091MNX/RNB device for the indicated nominal operating voltages. These current and power consumption values include the transmit driver current and on-chip regulator current for the 1.2V core.

Transceiver (3.3V), Digital I/Os (3.3V)

Table 10. Typical Current/Power Consumption (VDDA_3.3 = 3.3V, VDDIO = 3.3V)

Condition	3.3V Transceiver (VDDA_3.3)	3.3V Digital I/Os (VDDIO)	Total Chip Power
	mA	mA	mW
100Base-TX Link-up (no traffic)	34	12	152
100Base-TX Full-duplex @ 100% utilization	34	13	155
10Base-T Link-up (no traffic)	14	11	82.5
10Base-T Full-duplex @ 100% utilization	30	11	135
EEE 100Mbps Link-up mode (transmit and receive in LPI state with no traffic)	13	10	75.9
Power-saving mode (Reg. 1Fh, bit [10] = 1)	13	10	75.9
EDPD mode (Reg. 18h, bit [11] = 0)	10	10	66.0
EDPD mode (Reg. 18h, bit [11] = 0) and PLL off (Reg. 10h, bit [4] = 1)	3.77	1.54	17.5
Software power-down mode (Reg. 0h, bit [11] = 1)	2.59	1.51	13.5
Software power-down mode (Reg. 0h, bit [11] = 1) and slow-oscillator mode (Reg. 11h, bit [5] = 1)	1.36	0.45	5.97

Transceiver (3.3V), Digital I/Os (2.5V)

Table 11. Typical Current/Power Consumption (VDDA_3.3 = 3.3V, VDDIO = 2.5V)

Condition	3.3V Transceiver (VDDA_3.3)	2.5V Digital I/Os (VDDIO)	Total Chip Power
	mA	mA	mW
100Base-TX Link-up (no traffic)	34	11	140
100Base-TX Full-duplex @ 100% utilization	34	12	142
10Base-T Link-up (no traffic)	15	10	74.5
10Base-T Full-duplex @ 100% utilization	27	10	114
EEE 100Mbps Link-up mode (transmit and receive in LPI state with no traffic)	13	10	67.9
Power-saving mode (Reg. 1Fh, bit [10] = 1)	13	10	67.9
EDPD mode (Reg. 18h, bit [11] = 0)	11	10	61.3
EDPD mode (Reg. 18h, bit [11] = 0) and PLL off (Reg. 10h, bit [4] = 1)	3.55	1.35	15.1
Software power-down mode (Reg. 0h, bit [11] = 1)	2.29	1.34	10.9
Software power-down mode (Reg. 0h, bit [11] = 1) and slow-oscillator mode (Reg. 11h, bit [5] = 1)	1.15	0.29	4.52

Transceiver (3.3V), Digital I/Os (1.8V)**Table 12. Typical Current/Power Consumption (VDDA_3.3 = 3.3V, VDDIO = 1.8V)**

Condition	3.3V Transceiver (VDDA_3.3)	1.8V Digital I/Os (VDDIO)	Total Chip Power
	mA	mA	mW
100Base-TX Link-up (no traffic)	34	11	132
100Base-TX Full-duplex @ 100% utilization	34	12	134
10Base-T Link-up (no traffic)	15	9.0	65.7
10Base-T Full-duplex @ 100% utilization	27	9.0	105
EEE 100Mbps Link-up mode (transmit and receive in LPI state with no traffic)	13	9.0	59.1
Power-saving mode (Reg. 1Fh, bit [10] = 1)	13	9.0	59.1
EDPD mode (Reg. 18h, bit [11] = 0)	11	9.0	52.5
EDPD mode (Reg. 18h, bit [11] = 0) and PLL off (Reg. 10h, bit [4] = 1)	4.05	1.21	15.5
Software power-down mode (Reg. 0h, bit [11] = 1)	2.79	1.21	11.4
Software power-down mode (Reg. 0h, bit [11] = 1) and slow-oscillator mode (Reg. 11h, bit [5] = 1)	1.65	0.19	5.79

Register Map

The register space within the KSZ8091MNX/RNB consists of two distinct areas.

- Standard registers // Direct register access
- MDIO manageable device (MMD) registers // Indirect register access

The KSZ8091MNX/RNB supports the following standard registers.

Table 13. Standard Registers Supported by KSZ8091MNX/RNB

Register Number (Hex)	Description
IEEE-Defined Registers	
0h	Basic Control
1h	Basic Status
2h	PHY Identifier 1
3h	PHY Identifier 2
4h	Auto-Negotiation Advertisement
5h	Auto-Negotiation Link Partner Ability
6h	Auto-Negotiation Expansion
7h	Auto-Negotiation Next Page
8h	Auto-Negotiation Link Partner Next Page Ability
9h – Ch	Reserved
Dh	MMD Access – Control
Eh	MMD Access – Register/Data
Fh	Reserved
Vendor-Specific Registers	
10h	Digital Reserved Control
11h	AFE Control 1
12h	Reserved
13h	AFE Control 4
14h	Reserved
15h	RXER Counter
16h	Operation Mode Strap Override
17h	Operation Mode Strap Status
18h	Expanded Control
19h – 1Ah	Reserved
1Bh	Interrupt Control/Status
1Ch	Reserved
1Dh	LinkMD Cable Diagnostic
1Eh	PHY Control 1
1Fh	PHY Control 2

The KSZ8091MNX/RNB supports the following MMD device addresses and their associated register addresses, which make up the indirect MMD registers.

Table 14. MMD Registers Supported by KSZ8091MNX/RNB

Device Address (Hex)	Register Address (Hex)	Description
1h	0h	PMA/PMD Control 1
	1h	PMA/PMD Status 1
3h	0h	EEE PCS Control 1
7h	3Ch	EEE Advertisement
	3Dh	EEE Link Partner Advertisement
1Fh	0h	Wake-On-LAN – Control
	1h	Wake-On-LAN – Customized Packet, Type 0, Mask 0
	2h	Wake-On-LAN – Customized Packet, Type 0, Mask 1
	3h	Wake-On-LAN – Customized Packet, Type 0, Mask 2
	4h	Wake-On-LAN – Customized Packet, Type 0, Mask 3
	5h	Wake-On-LAN – Customized Packet, Type 0, Expected CRC 0
	6h	Wake-On-LAN – Customized Packet, Type 0, Expected CRC 1
	7h	Wake-On-LAN – Customized Packet, Type 1, Mask 0
	8h	Wake-On-LAN – Customized Packet, Type 1, Mask 1
	9h	Wake-On-LAN – Customized Packet, Type 1, Mask 2
	Ah	Wake-On-LAN – Customized Packet, Type 1, Mask 3
	Bh	Wake-On-LAN – Customized Packet, Type 1, Expected CRC 0
	Ch	Wake-On-LAN – Customized Packet, Type 1, Expected CRC 1
	Dh	Wake-On-LAN – Customized Packet, Type 2, Mask 0
	Eh	Wake-On-LAN – Customized Packet, Type 2, Mask 1
	Fh	Wake-On-LAN – Customized Packet, Type 2, Mask 2
	10h	Wake-On-LAN – Customized Packet, Type 2, Mask 3
	11h	Wake-On-LAN – Customized Packet, Type 2, Expected CRC 0
	12h	Wake-On-LAN – Customized Packet, Type 2, Expected CRC 1
	13h	Wake-On-LAN – Customized Packet, Type 3, Mask 0
	14h	Wake-On-LAN – Customized Packet, Type 3, Mask 1
	15h	Wake-On-LAN – Customized Packet, Type 3, Mask 2
	16h	Wake-On-LAN – Customized Packet, Type 3, Mask 3
	17h	Wake-On-LAN – Customized Packet, Type 3, Expected CRC 0
	18h	Wake-On-LAN – Customized Packet, Type 3, Expected CRC 1
	19h	Wake-On-LAN – Magic Packet, MAC-DA-0
	1Ah	Wake-On-LAN – Magic Packet, MAC-DA-1
	1Bh	Wake-On-LAN – Magic Packet, MAC-DA-2

Standard Registers

Standard registers provide direct read/write access to a 32-register address space, as defined in Clause 22 of the IEEE 802.3 Specification. Within this address space, the first 16 registers (Registers 0h to Fh) are defined according to the IEEE specification, while the remaining 16 registers (Registers 10h to 1Fh) are defined specific to the PHY vendor.

IEEE-Defined Registers – Descriptions

Address	Name	Description	Mode ⁽⁹⁾	Default
Register 0h – Basic Control				
0.15	Reset	1 = Software reset 0 = Normal operation This bit is self-cleared after a '1' is written to it.	RW/SC	0
0.14	Loopback	1 = Loopback mode 0 = Normal operation	RW	0
0.13	Speed Select	1 = 100Mbps 0 = 10Mbps This bit is ignored if auto-negotiation is enabled (register 0.12 = 1).	RW	Set by the SPEED strapping pin (KSZ8091RNB only). See the “ Strapping Options – KSZ8091RNB ” section for details.
0.12	Auto-Negotiation Enable	1 = Enable auto-negotiation process 0 = Disable auto-negotiation process If enabled, the auto-negotiation result overrides the settings in Registers 0.13 and 0.8.	RW	Set by the NWAYEN strapping pin. See the “ Strapping Options – KSZ8091MNX ” section for details.
0.11	Power-Down	1 = Power-down mode 0 = Normal operation If software reset (Register 0.15) is used to exit power-down mode (Register 0.11 = 1), two software reset writes (Register 0.15 = 1) are required. The first write clears power-down mode; the second write resets the chip and re-latches the pin strapping pin values.	RW	0
0.10	Isolate	1 = Electrical isolation of PHY from MII/RMII 0 = Normal operation	RW	Set by the ISO strapping pin. See the “ Strapping Options – KSZ8091MNX ” section for details.
0.9	Restart Auto-Negotiation	1 = Restart auto-negotiation process 0 = Normal operation. This bit is self-cleared after a '1' is written to it.	RW/SC	0
0.8	Duplex Mode	1 = Full-duplex 0 = Half-duplex	RW	The inverse of the DUPLEX strapping pin value. See the “ Strapping Options – KSZ8091MNX ” section for details.
0.7	Collision Test	1 = Enable COL test 0 = Disable COL test	RW	0
0.6:0	Reserved	Reserved	RO	000_0000
Register 1h – Basic Status				
1.15	100Base-T4	1 = T4 capable 0 = Not T4 capable	RO	0

Address	Name	Description	Mode ⁽⁹⁾	Default
1.14	100Base-TX Full-Duplex	1 = Capable of 100Mbps full-duplex 0 = Not capable of 100Mbps full-duplex	RO	1
1.13	100Base-TX Half-Duplex	1 = Capable of 100Mbps half-duplex 0 = Not capable of 100Mbps half-duplex	RO	1
1.12	10Base-T Full-Duplex	1 = Capable of 10Mbps full-duplex 0 = Not capable of 10Mbps full-duplex	RO	1
1.11	10Base-T Half-Duplex	1 = Capable of 10Mbps half-duplex 0 = Not capable of 10Mbps half-duplex	RO	1
1.10:7	Reserved	Reserved	RO	000_0
1.6	No Preamble	1 = Preamble suppression 0 = Normal preamble	RO	1
1.5	Auto-Negotiation Complete	1 = Auto-negotiation process completed 0 = Auto-negotiation process not completed	RO	0
1.4	Remote Fault	1 = Remote fault 0 = No remote fault	RO/LH	0
1.3	Auto-Negotiation Ability	1 = Can perform auto-negotiation 0 = Cannot perform auto-negotiation	RO	1
1.2	Link Status	1 = Link is up 0 = Link is down	RO/LL	0
1.1	Jabber Detect	1 = Jabber detected 0 = Jabber not detected (default is low)	RO/LH	0
1.0	Extended Capability	1 = Supports extended capability registers	RO	1

Register 2h – PHY Identifier 1

2.15:0	PHY ID Number	Assigned to the 3rd through 18th bits of the Organizationally Unique Identifier (OUI). KENDIN Communication's OUI is 0010A1 (hex).	RO	0022h
--------	---------------	--	----	-------

Register 3h – PHY Identifier 2

3.15:10	PHY ID Number	Assigned to the 19th through 24th bits of the Organizationally Unique Identifier (OUI). KENDIN Communication's OUI is 0010A1 (hex).	RO	0001_01
3.9:4	Model Number	Six-bit manufacturer's model number	RO	01_0110
3.3:0	Revision Number	Four-bit manufacturer's revision number	RO	Indicates silicon revision

Register 4h – Auto-Negotiation Advertisement

4.15	Next Page	1 = Next page capable 0 = No next page capability	RW	0
4.14	Reserved	Reserved	RO	0
4.13	Remote Fault	1 = Remote fault supported 0 = No remote fault	RW	0

Address	Name	Description	Mode ⁽⁹⁾	Default
4.12	Reserved	Reserved	RO	0
4.11:10	Pause	[00] = No pause [10] = Asymmetric pause [01] = Symmetric pause [11] = Asymmetric and symmetric pause	RW	00
4.9	100Base-T4	1 = T4 capable 0 = No T4 capability	RO	0
4.8	100Base-TX Full-Duplex	1 = 100Mbps full-duplex capable 0 = No 100Mbps full-duplex capability	RW	Set by the SPEED strapping pin (KSZ8091RNB only). See the “ Strapping Options – KSZ8091RNB ” section for details.
4.7	100Base-TX Half-Duplex	1 = 100Mbps half-duplex capable 0 = No 100Mbps half-duplex capability	RW	Set by the SPEED strapping pin (KSZ8091RNB only). See the “ Strapping Options – KSZ8091RNB ” section for details.
4.6	10Base-T Full-Duplex	1 = 10Mbps full-duplex capable 0 = No 10Mbps full-duplex capability	RW	1
4.5	10Base-T Half-Duplex	1 = 10Mbps half-duplex capable 0 = No 10Mbps half-duplex capability	RW	1
4.4:0	Selector Field	[00001] = IEEE 802.3	RW	0_0001
Register 5h – Auto-Negotiation Link Partner Ability				
5.15	Next Page	1 = Next page capable 0 = No next page capability	RO	0
5.14	Acknowledge	1 = Link code word received from partner 0 = Link code word not yet received	RO	0
5.13	Remote Fault	1 = Remote fault detected 0 = No remote fault	RO	0
5.12	Reserved	Reserved	RO	0
5.11:10	Pause	[00] = No pause [10] = Asymmetric pause [01] = Symmetric pause [11] = Asymmetric and symmetric pause	RO	00
5.9	100Base-T4	1 = T4 capable 0 = No T4 capability	RO	0
5.8	100Base-TX Full-Duplex	1 = 100Mbps full-duplex capable 0 = No 100Mbps full-duplex capability	RO	0
5.7	100Base-TX Half-Duplex	1 = 100Mbps half-duplex capable 0 = No 100Mbps half-duplex capability	RO	0
5.6	10Base-T Full-Duplex	1 = 10Mbps full-duplex capable 0 = No 10Mbps full-duplex capability	RO	0
5.5	10Base-T Half-Duplex	1 = 10Mbps half-duplex capable 0 = No 10Mbps half-duplex capability	RO	0

Address	Name	Description	Mode ⁽⁹⁾	Default
5.4:0	Selector Field	[00001] = IEEE 802.3	RO	0_0001
Register 6h – Auto-Negotiation Expansion				
6.15:5	Reserved	Reserved	RO	0000_0000_000
6.4	Parallel Detection Fault	1 = Fault detected by parallel detection 0 = No fault detected by parallel detection	RO/LH	0
6.3	Link Partner Next Page Able	1 = Link partner has next page capability 0 = Link partner does not have next page capability	RO	0
6.2	Next Page Able	1 = Local device has next page capability 0 = Local device does not have next page capability	RO	1
6.1	Page Received	1 = New page received 0 = New page not received yet	RO/LH	0
6.0	Link Partner Auto-Negotiation Able	1 = Link partner has auto-negotiation capability 0 = Link partner does not have auto-negotiation capability	RO	0
Register 7h – Auto-Negotiation Next Page				
7.15	Next Page	1 = Additional next pages will follow 0 = Last page	RW	0
7.14	Reserved	Reserved	RO	0
7.13	Message Page	1 = Message page 0 = Unformatted page	RW	1
7.12	Acknowledge2	1 = Will comply with message 0 = Cannot comply with message	RW	0
7.11	Toggle	1 = Previous value of the transmitted link code word equaled logic 1 0 = Logic 0	RO	0
7.10:0	Message Field	11-bit wide field to encode 2048 messages	RW	000_0000_0001
Register 8h – Auto-Negotiation Link Partner Next Page Ability				
8.15	Next Page	1 = Additional next pages will follow 0 = Last page	RO	0
8.14	Acknowledge	1 = Successful receipt of link word 0 = No successful receipt of link word	RO	0
8.13	Message Page	1 = Message page 0 = Unformatted page	RO	0
8.12	Acknowledge2	1 = Can act on the information 0 = Cannot act on the information	RO	0
8.11	Toggle	1 = Previous value of transmitted link code word equal to logic 0 0 = Previous value of transmitted link code word equal to logic 1	RO	0
8.10:0	Message Field	11-bit wide field to encode 2048 messages	RO	000_0000_0000

Address	Name	Description	Mode ⁽⁹⁾	Default
Register Dh – MMD Access – Control				
D.15:14	MMD – Operation Mode	For the selected MMD device address (bits [4:0] of this register), these two bits select one of the following register or data operations and the usage for MMD Access – Register/Data (Reg. Eh). 00 = Register 01 = Data, no post increment 10 = Data, post increment on reads and writes 11 = Data, post increment on writes only	RW	00
D.13:5	Reserved	Reserved	RW	00_0000_000
D.4:0	MMD – Device Address	These five bits set the MMD device address.	RW	0_0000
Register Eh – MMD Access – Register/Data				
E.15:0	MMD – Register/Data	For the selected MMD device address (Reg. Dh, bits [4:0]), When Reg. Dh, bits [15:14] = 00, this register contains the read/write register address for the MMD device address. Otherwise, this register contains the read/write data value for the MMD device address and its selected register address. See also Reg. Dh, bits [15:14], for descriptions of post increment reads and writes of this register for data operation.	RW	0000_0000_0000_0000

Note:

9. RW = Read/Write.
RO = Read only.
SC = Self-cleared.
LH = Latch high.
LL = Latch low.

Vendor-Specific Registers – Descriptions

Address	Name	Description	Mode ⁽¹⁰⁾	Default
Register 10h – Digital Reserved Control				
10.15:5	Reserved	Reserved	RW	0000_0000_000
10.4	PLL Off	1 = Turn PLL off automatically in EDPD mode 0 = Keep PLL on in EDPD mode. See also Register 18h, bit [11] for EDPD mode	RW	0
10.3:0	Reserved	Reserved	RW	0000
Register 11h – AFE Control 1				
11.15:6	Reserved	Reserved	RW	0000_0000_00
11.5	Slow-Oscillator Mode Enable	Slow-oscillator mode is used to disconnect the input reference crystal/clock on the XI pin and select the on-chip slow oscillator when the KSZ8091MNX/RNB device is not in use after power-up. 1 = Enable 0 = Disable This bit automatically sets software power-down to the analog side when enabled.	RW	0
11.4:0	Reserved	Reserved	RW	0_0000
Register 13h – AFE Control 4				
13.15:5	Reserved	Reserved	RW	0000_0000_000
13.4	10Base-Te Mode	1 = EEE 10Base-Te (1.75V TX amplitude) 0 = Standard 10Base-T (2.5V TX amplitude)	RW	0
13.3:0	Reserved	Reserved	RW	0000
Register 15h – RXER Counter				
15.15:0	RXER Counter	Receive error counter for symbol error frames	RO/SC	0000h
Register 16h – Operation Mode Strap Override				
16.15	PME Enable	PME for Wake-on-LAN 1 = Enable 0 = Disable This bit works in conjunction with MMD Address 1Fh, Reg. 0h, Bits [15:14] to define the output for pins 21 and 30.	RW	Set by the PME_EN strapping pin. See the “ Strapping Options – KSZ8091MNX ” section for details.
16.14:11	Reserved	Reserved	RW	000_0
16.10	Reserved	Reserved	RO	0
16.9	B-CAST_OFF Override	1 = Override strap-in for B-CAST_OFF If bit is ‘1’, PHY Address 0 is non-broadcast.	RW	0
16.8	Reserved	Reserved	RW	0
16.7	MII B-to-B Override	1 = Override strap-in for MII back-to-back mode (also set bit 0 of this register to ‘1’) This bit applies only to KSZ8091MNX.	RW	0

Address	Name	Description	Mode ⁽¹⁰⁾	Default
16.6	RMII B-to-B Override	1 = Override strap-in for RMII Back-to-Back mode (also set bit 1 of this register to '1') This bit applies only to KSZ8091RNB.	RW	0
16.5	NAND Tree Override	1 = Override strap-in for NAND tree mode	RW	0
16.4:2	Reserved	Reserved	RW	0_00
16.1	RMII Override	1 = Override strap-in for RMII mode This bit applies only to KSZ8091RNB.	RW	0
16.0	MII Override	1 = Override strap-in for MII mode This bit applies only to KSZ8091MNX.	RW	1
Register 17h – Operation Mode Strap Status				
17.15:13	PHYAD[2:0] Strap-In Status	[000] = Strap to PHY Address 0 [001] = Strap to PHY Address 1 [010] = Strap to PHY Address 2 [011] = Strap to PHY Address 3 [100] = Strap to PHY Address 4 [101] = Strap to PHY Address 5 [110] = Strap to PHY Address 6 [111] = Strap to PHY Address 7	RO	
17.12:10	Reserved	Reserved	RO	
17.9	B-CAST_OFF Strap-In Status	1 = Strap to B-CAST_OFF If bit is '1', PHY Address 0 is non-broadcast.	RO	
17.8	Reserved	Reserved	RO	
17.7	MII B-to-B Strap-In Status	1 = Strap to MII back-to-back mode This bit applies only to KSZ8091MNX.	RO	
17.6	RMII B-to-B Strap-In Status	1 = Strap to RMII Back-to-Back mode This bit applies only to KSZ8091RNB.	RO	
17.5	NAND Tree Strap-In Status	1 = Strap to NAND tree mode	RO	
17.4:2	Reserved	Reserved	RO	
17.1	RMII Strap-In Status	1 = Strap to RMII mode This bit applies only to KSZ8091RNB.	RO	
17.0	MII Strap-In Status	1 = Strap to MII mode This bit applies only to KSZ8091MNX.	RO	
Register 18h – Expanded Control				
18.15:12	Reserved	Reserved	RW	0000
18.11	EDPD Disabled	Energy-detect power-down mode 1 = Disable 0 = Enable See also Register 10h, bit [4] for PLL off.	RW	1

Address	Name	Description	Mode ⁽¹⁰⁾	Default
18.10	100Base-TX Latency	1 = MII output is random latency 0 = MII output is fixed latency For both settings, all bytes of received preamble are passed to the MII output. This bit applies only to the KSZ8091MNX.	RW	0
18.9:7	Reserved	Reserved	RW	00_0
18.6	10Base-T Preamble Restore	1 = Restore received preamble to MII output 0 = Remove all seven bytes of preamble before sending frame (starting with SFD) to MII output This bit applies only to the KSZ8091MNX.	RW	0
18.5:0	Reserved	Reserved	RW	00_0001
Register 1Bh – Interrupt Control/Status				
1B.15	Jabber Interrupt Enable	1 = Enable jabber interrupt 0 = Disable jabber interrupt	RW	0
1B.14	Receive Error Interrupt Enable	1 = Enable receive error interrupt 0 = Disable receive error interrupt	RW	0
1B.13	Page Received Interrupt Enable	1 = Enable page received interrupt 0 = Disable page received interrupt	RW	0
1B.12	Parallel Detect Fault Interrupt Enable	1 = Enable parallel detect fault interrupt 0 = Disable parallel detect fault interrupt	RW	0
1B.11	Link Partner Acknowledge Interrupt Enable	1 = Enable link partner acknowledge interrupt 0 = Disable link partner acknowledge interrupt	RW	0
1B.10	Link-Down Interrupt Enable	1 = Enable link-down interrupt 0 = Disable link-down interrupt	RW	0
1B.9	Remote Fault Interrupt Enable	1 = Enable remote fault interrupt 0 = Disable remote fault interrupt	RW	0
1B.8	Link-Up Interrupt Enable	1 = Enable link-up interrupt 0 = Disable link-up interrupt	RW	0
1B.7	Jabber Interrupt	1 = Jabber occurred 0 = Jabber did not occur	RO/SC	0
1B.6	Receive Error Interrupt	1 = Receive error occurred 0 = Receive error did not occur	RO/SC	0
1B.5	Page Receive Interrupt	1 = Page receive occurred 0 = Page receive did not occur	RO/SC	0
1B.4	Parallel Detect Fault Interrupt	1 = Parallel detect fault occurred 0 = Parallel detect fault did not occur	RO/SC	0

Address	Name	Description	Mode ⁽¹⁰⁾	Default
1B.3	Link Partner Acknowledge Interrupt	1 = Link partner acknowledge occurred 0 = Link partner acknowledge did not occur	RO/SC	0
1B.2	Link-Down Interrupt	1 = Link-down occurred 0 = Link-down did not occur	RO/SC	0
1B.1	Remote Fault Interrupt	1 = Remote fault occurred 0 = Remote fault did not occur	RO/SC	0
1B.0	Link-Up Interrupt	1 = Link-up occurred 0 = Link-up did not occur	RO/SC	0
Register 1Dh – LinkMD Cable Diagnostic				
1D.15	Cable Diagnostic Test Enable	1 = Enable cable diagnostic test. After test has completed, this bit is self-cleared. 0 = Indicates cable diagnostic test (if enabled) has completed and the status information is valid for read.	RW/SC	0
1D.14:13	Cable Diagnostic Test Result	[00] = Normal condition [01] = Open condition has been detected in cable [10] = Short condition has been detected in cable [11] = Cable diagnostic test has failed	RO	00
1D.12	Short Cable Indicator	1 = Short cable (<10 meter) has been detected by LinkMD	RO	0
1D.11:9	Reserved	Reserved	RW	000
1D.8:0	Cable Fault Counter	Distance to fault	RO	0_0000_0000
Register 1Eh – PHY Control 1				
1E.15:10	Reserved	Reserved	RO	0000_00
1E.9	Enable Pause (Flow Control)	1 = Flow control capable 0 = No flow control capability	RO	0
1E.8	Link Status	1 = Link is up 0 = Link is down	RO	0
1E.7	Polarity Status	1 = Polarity is reversed 0 = Polarity is not reversed	RO	
1E.6	Reserved	Reserved	RO	0
1E.5	MDI/MDI-X State	1 = MDI-X 0 = MDI	RO	
1E.4	Energy Detect	1 = Signal present on receive differential pair 0 = No signal detected on receive differential pair	RO	0
1E.3	PHY Isolate	1 = PHY in isolate mode 0 = PHY in normal operation	RW	0

Address	Name	Description	Mode ⁽¹⁰⁾	Default
1E.2:0	Operation Mode Indication	[000] = Still in auto-negotiation [001] = 10Base-T half-duplex [010] = 100Base-TX half-duplex [011] = Reserved [100] = Reserved [101] = 10Base-T full-duplex [110] = 100Base-TX full-duplex [111] = Reserved	RO	000
Register 1Fh – PHY Control 2				
1F.15	HP_MDIX	1 = HP Auto MDI/MDI-X mode 0 = Micrel Auto MDI/MDI-X mode	RW	1
1F.14	MDI/MDI-X Select	When Auto MDI/MDI-X is disabled, 1 = MDI-X mode Transmit on RXP,RXM (pins 5, 4) and Receive on TXP,TXM (pins 7, 6) 0 = MDI mode Transmit on TXP,TXM (pins 7, 6) and Receive on RXP,RXM (pins 5, 4)	RW	0
1F.13	Pair Swap Disable	1 = Disable Auto MDI/MDI-X 0 = Enable Auto MDI/MDI-X	RW	0
1F.12	Reserved	Reserved	RW	0
1F.11	Force Link	1 = Force link pass 0 = Normal link operation This bit bypasses the control logic and allows the transmitter to send a pattern even if there is no link.	RW	0
1F.10	Power Saving	1 = Enable power saving 0 = Disable power saving	RW	0
1F.9	Interrupt Level	1 = Interrupt pin active high 0 = Interrupt pin active low	RW	0
1F.8	Enable Jabber	1 = Enable jabber counter 0 = Disable jabber counter	RW	1
1F.7	RMII Reference Clock Select	1 = RMII 50MHz clock mode; clock input to XI (pin 9) is 50MHz 0 = RMII 25MHz clock mode; clock input to XI (pin 9) is 25MHz This bit applies only to KSZ8091RNB.	RW	0
1F.6	Reserved	Reserved	RW	0

Address	Name	Description	Mode ⁽¹⁰⁾	Default
1F.5:4	LED Mode	[00] = LED1: Speed LED0: Link/Activity [01] = LED1: Activity LED0: Link [10], [11] = Reserved The LED1 pin applies only to the KSZ8091RNB.	RW	00
1F.3	Disable Transmitter	1 = Disable transmitter 0 = Enable transmitter	RW	0
1F.2	Remote Loopback	1 = Remote (analog) loopback is enabled 0 = Normal mode	RW	0
1F.1	Enable SQE Test	1 = Enable SQE test 0 = Disable SQE test	RW	0
1F.0	Disable Data Scrambling	1 = Disable scrambler 0 = Enable scrambler	RW	0

Note:

10. RW = Read/Write.

RO = Read only.

SC = Self-cleared.

MMD Registers

MMD registers provide indirect read/write access to up to 32 MMD Device Addresses with each device supporting up to 65,536 16-bit registers, as defined in Clause 22 of the IEEE 802.3 Specification. The KSZ8091MNX/RNB, however, uses only a small fraction of the available registers. See the “[Register Map](#)” section for a list of supported MMD device addresses and their associated register addresses.

The following two standard registers serve as the portal registers to access the indirect MMD registers.

- Standard register Dh – MMD Access – Control
- Standard register Eh – MMD Access – Register/Data

Table 15. Portal Registers (Access to Indirect MMD Registers)

Address	Name	Description	Mode	Default
Register Dh – MMD Access – Control				
D.15:14	MMD – Operation Mode	For the selected MMD device address (bits [4:0] of this register), these two bits select one of the following register or data operations and the usage for MMD Access – Register/Data (Reg. Eh). 00 = Register 01 = Data, no post increment 10 = Data, post increment on reads and writes 11 = Data, post increment on writes only	RW	00
D.13:5	Reserved	Reserved	RW	00_0000_000
D.4:0	MMD – Device Address	These five bits set the MMD device address.	RW	0_0000
Register Eh – MMD Access – Register/Data				
E.15:0	MMD – Register/Data	For the selected MMD device address (Reg. Dh, bits [4:0]), When Reg. Dh, bits [15:14] = 00, this register contains the read/write register address for the MMD device address. Otherwise, this register contains the read/write data value for the MMD device address and its selected register address. See also Register Dh, bits [15:14] descriptions for post increment reads and writes of this register for data operation.	RW	0000_0000_0000_0000

Examples:

MMD Register Write

Write MMD – Device Address 1Fh, Register 0h = 0001h to enable link-up detection to trigger PME for WOL.

1. Write Register Dh with 001Fh // Set up register address for MMD – Device Address 1Fh.
2. Write Register Eh with 0000h // Select register 0h of MMD – Device Address 1Fh.
3. Write Register Dh with 401Fh // Select register data for MMD – Device Address 1Fh, Register 0h.
4. Write Register Eh with 0001h // Write value 0001h to MMD – Device Address 1Fh, Register 0h.

MMD Register Read

Read MMD – Device Address 1Fh, Register 19h – 1Bh for the magic packet's MAC address

1. Write Register Dh with 001Fh // Set up register address for MMD – Device Address 1Fh.
2. Write Register Eh with 0019h // Select Register 19h of MMD – Device Address 1Fh.
3. Write Register Dh with 801Fh // Select register data for MMD – Device Address 1Fh, Register 19h
// with post increments
4. Read Register Eh // Read data in MMD – Device Address 1Fh, Register 19h.
5. Read Register Eh // Read data in MMD – Device Address 1Fh, Register 1Ah.
6. Read Register Eh // Read data in MMD – Device Address 1Fh, Register 1Bh.

MMD Registers – Descriptions

Address	Name	Description	Mode ⁽¹¹⁾	Default
MMD Address 1h, Register 0h – PMA/PMD Control 1				
1.0.15:13	Reserved	Reserved	RW	000
1.0.12	LPI enable	Lower Power Idle enable	RW	0
1.0.11:0	Reserved	Reserved	RW	0000_0000_0000
MMD Address 1h, Register 1h – PMA/PMD Status 1				
1.1.15:9	Reserved	Reserved	RO	0000_000
1.1.8	LPI State Entered	1 = PMA/PMD has entered LPI state 0 = PMA/PMD has not entered LPI state	RO/LH	0
1.1.7:4	Reserved	Reserved	RO	0000
1.1.3	LPI State Indication	1 = PMA/PMD is currently in LPI state 0 = PMA/PMD is currently not in LPI state	RO	0
1.1.2:0	Reserved	Reserved	RO	000
MMD Address 3h, Register 0h – EEE PCS Control 1				
3.0.15:12	Reserved	Reserved	RO	0000
3.0.11	Reserved	Reserved	RW	1
3.0.10	100Base-TX RXC Clock Stoppable	During receive lower-power idle mode, 1 = RXC clock is stoppable for 100Base-TX 0 = RXC clock is not stoppable for 100Base-TX This bit applies only to KSZ8091MNX.	RW	1
3.0.9:4	Reserved	Reserved	RW	00_0001
3.0.3:2	Reserved	Reserved	RO	00
3.0.1:0	Reserved	Reserved	RW	00
MMD Address 7h, Register 3Ch – EEE Advertisement				
7.3C.15:3	Reserved	Reserved	RO	0000_0000_0000_0
7.3C.2	1000Base-T EEE Capable	0 = 1000Mbps EEE is not supported	RO	0

Address	Name	Description	Mode ⁽¹¹⁾	Default
7.3C.1	100Base-TX EEE Capable	1 = 100Mbps EEE capable 0 = No 100Mbps EEE capability This bit is set to '0' as the default after power-up or reset. Set this bit to '1' to enable 100Mbps EEE mode.	RW	0
7.3C.0	Reserved	Reserved	RO	0
MMD Address 7h, Register 3Dh – EEE Link Partner Advertisement				
7.3D.15:3	Reserved	Reserved	RO	0000_0000_0000_0
7.3D.2	1000Base-T EEE Capable	1 = 1000Mbps EEE capable 0 = No 1000Mbps EEE capability	RO	0
7.3D.1	100Base-TX EEE Capable	1 = 100Mbps EEE capable 0 = No 100Mbps EEE capability	RO	0
7.3D.0	Reserved	Reserved	RO	0
MMD Address 1Fh, Register 0h – Wake-On-LAN – Control				
1F.0.15:14	PME Output Select	These two bits work in conjunction with Reg. 16h, Bit [15] for PME enable to define the output for pins 21 and 30. INTRP/PME_N2 (pin 21) 00 = INTRP output 01 = PME_N2 output 10 = INTRP and PME_N2 output 11 = Reserved LED0/PME_N1 (pin 30) 00 = PME_N1 output 01 = LED0 output 10 = LED0 output 11 = PME_N1 output	RW	00
1F.0.13:7	Reserved	Reserved	RO	00_0000_0
1F.0.6	Magic Packet Detect Enable	1 = Enable magic-packet detection 0 = Disable magic-packet detection	RW	0
1F.0.5	Custom- Packet Type 3 Detect Enable	1 = Enable custom-packet, Type 3 detection 0 = Disable custom-packet, Type 3 detection	RW	0
1F.0.4	Custom- Packet Type 2 Detect Enable	1 = Enable custom-packet, Type 2 detection 0 = Disable custom-packet, Type 2 detection	RW	0
1F.0.3	Custom- Packet Type 1 Detect Enable	1 = Enable custom-packet, Type 1 detection 0 = Disable custom-packet, Type 1 detection	RW	0
1F.0.2	Custom- Packet Type 0 Detect Enable	1 = Enable custom-packet, Type 0 detection 0 = Disable custom-packet, Type 0 detection	RW	0
1F.0.1	Link-Down Detect Enable	1 = Enable link-down detection 0 = Disable link-down detection	RW	0

Address	Name	Description	Mode ⁽¹¹⁾	Default
1F.0.0	Link-Up Detect Enable	1 = Enable link-up detection 0 = Disable link-up detection	RW	0
MMD Address 1Fh, Register 1h – Wake-On-LAN – Customized Packet, Type 0, Mask 0				
MMD Address 1Fh, Register 7h – Wake-On-LAN – Customized Packet, Type 1, Mask 0				
MMD Address 1Fh, Register Dh – Wake-On-LAN – Customized Packet, Type 2, Mask 0				
MMD Address 1Fh, Register 13h – Wake-On-LAN – Customized Packet, Type 3, Mask 0				
1F.1.15:0 1F.7.15:0 1F.D.15:0 1F.13.15:0	Custom Packet Type X Mask 0	This register selects the bytes in the first 16 bytes of the packet (bytes 1 thru 16) that will be used for CRC calculation. For each bit in this register, 1 = Byte is selected for CRC calculation 0 = Byte is not selected for CRC calculation The register-bit to packet-byte mapping is as follows: Bit [15] : byte-16 ... : ... Bit [1] : byte-2 Bit [0] : byte-1	RW	0000_0000_0000_0000
MMD Address 1Fh, Register 2h – Wake-On-LAN – Customized Packet, Type 0, Mask 1				
MMD Address 1Fh, Register 8h – Wake-On-LAN – Customized Packet, Type 1, Mask 1				
MMD Address 1Fh, Register Eh – Wake-On-LAN – Customized Packet, Type 2, Mask 1				
MMD Address 1Fh, Register 14h – Wake-On-LAN – Customized Packet, Type 3, Mask 1				
1F.2.15:0 1F.8.15:0 1F.E.15:0 1F.14.15:0	Custom Packet Type X Mask 1	This register selects the bytes in the second 16 bytes of the packet (bytes 17 thru 32) that will be used for CRC calculation. For each bit in this register, 1 = Byte is selected for CRC calculation 0 = Byte is not selected for CRC calculation The register-bit to packet-byte mapping is as follows: Bit [15] : byte-32 ... : ... Bit [1] : byte-18 Bit [0] : byte-17	RW	0000_0000_0000_0000

Address	Name	Description	Mode ⁽¹¹⁾	Default
MMD Address 1Fh, Register 3h – Wake-On-LAN – Customized Packet, Type 0, Mask 2				
MMD Address 1Fh, Register 9h – Wake-On-LAN – Customized Packet, Type 1, Mask 2				
MMD Address 1Fh, Register Fh – Wake-On-LAN – Customized Packet, Type 2, Mask 2				
MMD Address 1Fh, Register 15h – Wake-On-LAN – Customized Packet, Type 3, Mask 2				
1F.3.15:0 1F.9.15:0 1F.F.15:0 1F.15.15:0	Custom Packet Type X Mask 2	This register selects the bytes in the third 16 bytes of the packet (bytes 33 thru 48) that will be used for CRC calculation. For each bit in this register, 1 = Byte is selected for CRC calculation 0 = Byte is not selected for CRC calculation The register-bit to packet-byte mapping is as follows: Bit [15] : byte-48 ... : ... Bit [1] : byte-34 Bit [0] : byte-33	RW	0000_0000_0000_0000
MMD Address 1Fh, Register 4h – Wake-On-LAN – Customized Packet, Type 0, Mask 3				
MMD Address 1Fh, Register Ah – Wake-On-LAN – Customized Packet, Type 1, Mask 3				
MMD Address 1Fh, Register 10h – Wake-On-LAN – Customized Packet, Type 2, Mask 3				
MMD Address 1Fh, Register 16h – Wake-On-LAN – Customized Packet, Type 3, Mask 3				
1F.4.15:0 1F.A.15:0 1F.10.15:0 1F.16.15:0	Custom Packet Type X Mask 3	This register selects the bytes in the fourth 16 bytes of the packet (bytes 49 thru 64) that will be used for CRC calculation. For each bit in this register, 1 = Byte is selected for CRC calculation 0 = Byte is not selected for CRC calculation The register-bit to packet-byte mapping is as follows: Bit [15] : byte-64 ... : ... Bit [1] : byte-50 Bit [0] : byte-49	RW	0000_0000_0000_0000
MMD Address 1Fh, Register 5h – Wake-On-LAN – Customized Packet, Type 0, Expected CRC 0				
MMD Address 1Fh, Register Bh – Wake-On-LAN – Customized Packet, Type 1, Expected CRC 0				
MMD Address 1Fh, Register 11h – Wake-On-LAN – Customized Packet, Type 2, Expected CRC 0				
MMD Address 1Fh, Register 17h – Wake-On-LAN – Customized Packet, Type 3, Expected CRC 0				
1F.5.15:0 1F.B.15:0 1F.11.15:0 1F.17.15:0	Custom Packet Type X CRC 0	This register stores the lower two bytes for the expected CRC. Bit [15:8]= Byte 2 (CRC [15:8]) Bit [7:0] = Byte 1 (CRC [7:0]) The upper two bytes for the expected CRC are stored in the following register.	RW	0000_0000_0000_0000

Address	Name	Description	Mode ⁽¹¹⁾	Default
MMD Address 1Fh, Register 6h – Wake-On-LAN – Customized Packet, Type 0, Expected CRC 1				
MMD Address 1Fh, Register Ch – Wake-On-LAN – Customized Packet, Type 1, Expected CRC 1				
MMD Address 1Fh, Register 12h – Wake-On-LAN – Customized Packet, Type 2, Expected CRC 1				
MMD Address 1Fh, Register 18h – Wake-On-LAN – Customized Packet, Type 3, Expected CRC 1				
1F.6.15:0 1F.C.15:0 1F.12.15:0 1F.18.15:0	Custom Packet Type X CRC 1	This register stores the upper two bytes for the expected CRC. Bit [15:8]= Byte 4 (CRC [31:24]) Bit [7:0] = Byte 3 (CRC [23:16]) The lower two bytes for the expected CRC are stored in the previous register.	RW	0000_0000_0000_0000
MMD Address 1Fh, Register 19h – Wake-On-LAN – Magic Packet, MAC-DA-0				
1F.19.15:0	Magic Packet MAC-DA-0	This register stores the lower two bytes of the destination MAC address for the magic packet. Bit [15:8]= Byte 2 (MAC Address [15:8]) Bit [7:0] = Byte 1 (MAC Address [7:0]) The upper four bytes of the destination MAC address are stored in the following two registers.	RW	0000_0000_0000_0000
MMD Address 1Fh, Register 1Ah – Wake-On-LAN – Magic Packet, MAC-DA-1				
1F.1A.15:0	Magic Packet MAC-DA-1	This register stores the middle two bytes of the destination MAC address for the magic packet. Bit [15:8]= Byte 4 (MAC Address [31:24]) Bit [7:0] = Byte 3 (MAC Address [23:16]) The lower two bytes and upper two bytes of the destination MAC address are stored in the previous and following registers, respectively.	RW	0000_0000_0000_0000
MMD Address 1Fh, Register 1Bh – Wake-On-LAN – Magic Packet, MAC-DA-2				
1F.1B.15:0	Magic Packet MAC-DA-2	This register stores the upper two bytes of the destination MAC address for the magic packet. Bit [15:8]= Byte 6 (MAC Address [47:40]) Bit [7:0] = Byte 5 (MAC Address [39:32]) The lower four bytes of the destination MAC address are stored in the previous two registers.	RW	0000_0000_0000_0000

Note:

11. RW = Read/Write.
RO = Read only.
LH = Latch high.

Absolute Maximum Ratings⁽¹²⁾

Supply Voltage (V_{IN})	
($V_{DD_1.2}$)	-0.5V to +1.8V
($V_{DDIO}, V_{DDA_3.3}$)	-0.5V to +5.0V
Input Voltage (all inputs)	-0.5V to +5.0V
Output Voltage (all outputs)	-0.5V to +5.0V
Lead Temperature (soldering, 10s)	260°C
Storage Temperature (T_s)	-55°C to +150°C

Operating Ratings⁽¹³⁾

Supply Voltage	
($V_{DDIO_3.3}, V_{DDA_3.3}$)	+3.135V to +3.465V
($V_{DDIO_2.5}$)	+2.375V to +2.625V
($V_{DDIO_1.8}$)	+1.710V to +1.890V
Ambient Temperature	
(T_A , Commercial)	0°C to +70°C
(T_A , Industrial)	-40°C to +85°C
Maximum Junction Temperature (T_{Jmax})	125°C
Thermal Resistance (θ_{JA})	34°C/W
Thermal Resistance (θ_{JC})	6°C/W

Electrical Characteristics⁽¹⁴⁾

Symbol	Parameter	Condition	Min.	Typ.	Max.	Units
Supply Current ($V_{DDIO}, V_{DDA_3.3} = 3.3V$)⁽¹⁵⁾						
$I_{DD1_3.3V}$	10Base-T	Full-duplex traffic @ 100% utilization		41		mA
$I_{DD2_3.3V}$	100Base-TX	Full-duplex traffic @ 100% utilization		47		mA
$I_{DD3_3.3V}$	EEE (100Mbps) Mode	TX and RX paths in LPI state with no traffic		23		mA
$I_{DD4_3.3V}$	EDPD Mode	Ethernet cable disconnected (Reg. 18h.11 = 0)		20		mA
$I_{DD5_3.3V}$	Power-Down Mode	Software power-down (Reg. 0h.11 = 1)		4		mA
CMOS Level Inputs						
V_{IH}	Input High Voltage	$V_{DDIO} = 3.3V$	2.0			V
		$V_{DDIO} = 2.5V$	1.8			V
		$V_{DDIO} = 1.8V$	1.3			V
V_{IL}	Input Low Voltage	$V_{DDIO} = 3.3V$			0.8	V
		$V_{DDIO} = 2.5V$			0.7	V
		$V_{DDIO} = 1.8V$			0.5	V
$ I_{IN} $	Input Current	$V_{IN} = GND \sim V_{DDIO}$			10	μA
CMOS Level Outputs						
V_{OH}	Output High Voltage	$V_{DDIO} = 3.3V$	2.4			V
		$V_{DDIO} = 2.5V$	2.0			V
		$V_{DDIO} = 1.8V$	1.5			V
V_{OL}	Output Low Voltage	$V_{DDIO} = 3.3V$			0.4	V
		$V_{DDIO} = 2.5V$			0.4	V
		$V_{DDIO} = 1.8V$			0.3	V
$ I_{oz} $	Output Tri-State Leakage				10	μA
LED Output						
I_{LED}	Output Drive Current	Each LED pin (LED0, LED1)		8		mA

Notes:

12. Exceeding the absolute maximum ratings may damage the device. Stresses greater than the absolute maximum rating can cause permanent damage to the device. Operation of the device at these or any other conditions above those specified in the operating sections of this specification is not implied. Maximum conditions for extended periods may affect reliability.
13. The device is not guaranteed to function outside its operating ratings.
14. $T_A = 25^\circ C$. Specification for packaged product only.
15. Current consumption is for the single 3.3V supply KSZ8091MNX/RNB device only, and includes the transmit driver current and the 1.2V supply voltage ($V_{DD_1.2}$) that are supplied by the KSZ8091MNX/RNB.

Symbol	Parameter	Condition	Min.	Typ.	Max.	Units
All Pull-Up/Pull-Down Pins (including Strapping Pins)						
pu	Internal Pull-Up Resistance	$V_{DDIO} = 3.3V$	30	45	73	k Ω
		$V_{DDIO} = 2.5V$	39	61	102	k Ω
		$V_{DDIO} = 1.8V$	48	99	178	k Ω
pd	Internal Pull-Down Resistance	$V_{DDIO} = 3.3V$	26	43	79	k Ω
		$V_{DDIO} = 2.5V$	34	59	113	k Ω
		$V_{DDIO} = 1.8V$	53	99	200	k Ω
100Base-TX Transmit (measured differentially after 1:1 transformer)						
V_O	Peak Differential Output Voltage	100 Ω termination across differential output	0.95		1.05	V
V_{IMB}	Output Voltage Imbalance	100 Ω termination across differential output			2	%
t_r, t_f	Rise/Fall Time		3		5	ns
	Rise/Fall Time Imbalance		0		0.5	ns
	Duty Cycle Distortion				± 0.25	ns
	Overshoot				5	%
	Output Jitter	Peak-to-peak		0.7		ns
10Base-T Transmit (measured differentially after 1:1 transformer)						
V_P	Peak Differential Output Voltage	100 Ω termination across differential output	2.2		2.8	V
	Jitter Added	Peak-to-peak			3.5	ns
t_r, t_f	Rise/Fall Time			25		ns
10Base-T Receive						
V_{SQ}	Squelch Threshold	5MHz square wave		400		mV
Transmitter – Drive Setting						
V_{SET}	Reference Voltage of I_{SET}	$R(I_{SET}) = 6.49k\Omega$		0.65		V
REF_CLK Output						
	50MHz RMII Clock Output Jitter	Peak-to-peak (Applies only to KSZ8091RNB in RMII – 25MHz clock mode)		300		ps
100Mbps Mode – Industrial Applications Parameters						
	Clock Phase Delay – XI Input to MII TXC Output	XI (25MHz clock input) to MII TXC (25MHz clock output) delay, referenced to rising edges of both clocks. (Applies only to KSZ8091MNX in MII mode)	15	20	25	ns
t_{lr}	Link Loss Reaction (Indication) Time	Link loss detected at receive differential inputs to PHY signal indication time for each of the following: 1. For LED mode 00 (KSZ8091RNB only), Speed LED output changes from low (100Mbps) to high (10Mbps, default state for link-down). 2. For LED mode 01, Link LED output changes from low (link-up) to high (link-down). 3. INTRP pin asserts for link-down status change.		4.4		μs

Timing Diagrams

MII SQE Timing (10Base-T)

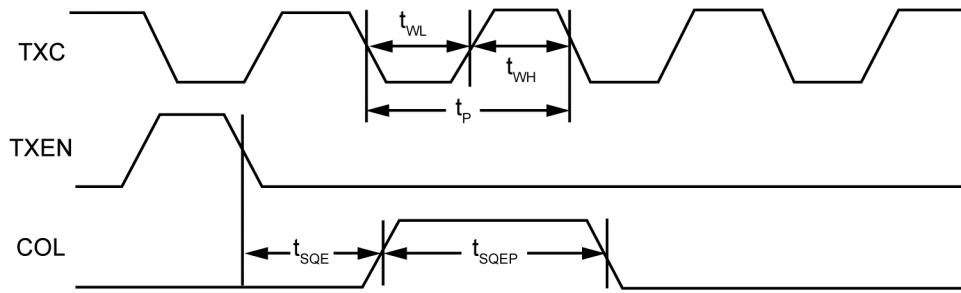

Figure 16. MII SQE Timing (10Base-T)

Table 16. MII SQE Timing (10Base-T) Parameters

Timing Parameter	Description	Min.	Typ.	Max.	Unit
t_P	TXC period		400		ns
t_{WL}	TXC pulse width low		200		ns
t_{WH}	TXC pulse width high		200		ns
t_{SQE}	COL (SQE) delay after TXEN de-asserted		2.2		μ s
t_{SQEP}	COL (SQE) pulse duration		1.0		μ s

MII Transmit Timing (10Base-T)

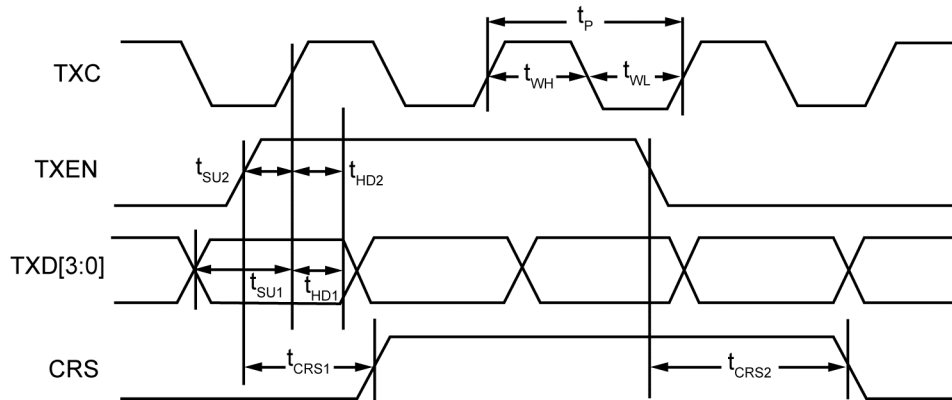

Figure 17. MII Transmit Timing (10Base-T)

Table 17. MII Transmit Timing (10Base-T) Parameters

Timing Parameter	Description	Min.	Typ.	Max.	Unit
t_p	TXC period		400		ns
t_{WL}	TXC pulse width low		200		ns
t_{WH}	TXC pulse width high		200		ns
t_{SU1}	TXD[3:0] setup to rising edge of TXC	120			ns
t_{SU2}	TXEN setup to rising edge of TXC	120			ns
t_{HD1}	TXD[3:0] hold from rising edge of TXC	0			ns
t_{HD2}	TXEN hold from rising edge of TXC	0			ns
t_{CRS1}	TXEN high to CRS asserted latency		600		ns
t_{CRS2}	TXEN low to CRS de-asserted latency		1.0		μ s

MII Receive Timing (10Base-T)

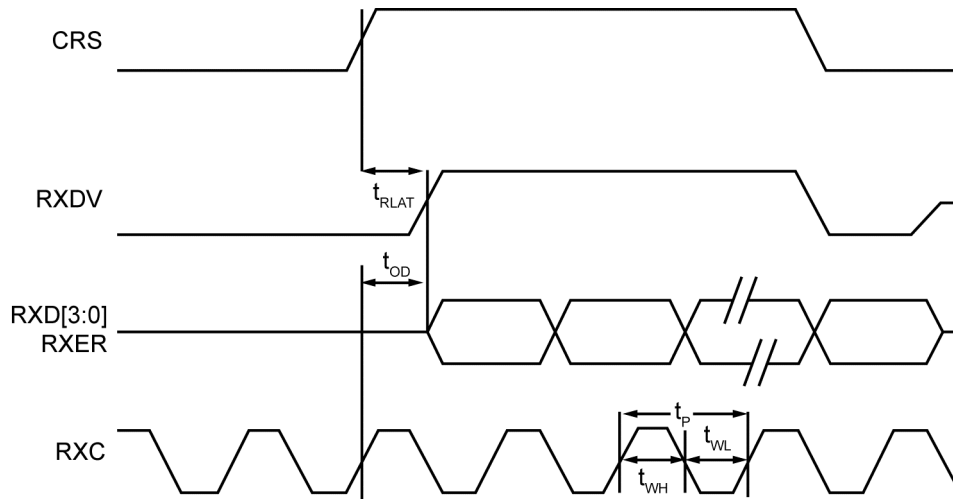

Figure 18. MII Receive Timing (10Base-T)

Table 18. MII Receive Timing (10Base-T) Parameters

Timing Parameter	Description	Min.	Typ.	Max.	Unit
t_P	RXC period		400		ns
t_{WL}	RXC pulse width low		200		ns
t_{WH}	RXC pulse width high		200		ns
t_{OD}	(RXDV, RXD[3:0], RXER) output delay from rising edge of RXC		205		ns
t_{RLAT}	CRS to (RXDV, RXD[3:0]) latency		7.2		μ s

MII Transmit Timing (100Base-TX)

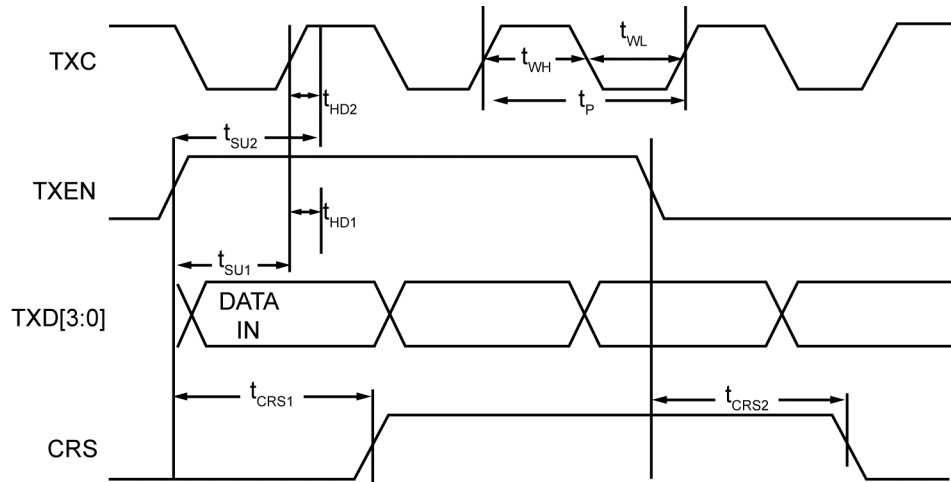

Figure 19. MII Transmit Timing (100Base-TX)

Table 19. MII Transmit Timing (100Base-TX) Parameters

Timing Parameter	Description	Min.	Typ.	Max.	Unit
t_P	TXC period		40		ns
t_{WL}	TXC pulse width low		20		ns
t_{WH}	TXC pulse width high		20		ns
t_{SU1}	TXD[3:0] setup to rising edge of TXC	10			ns
t_{SU2}	TXEN setup to rising edge of TXC	10			ns
t_{HD1}	TXD[3:0] hold from rising edge of TXC	0			ns
t_{HD2}	TXEN hold from rising edge of TXC	0			ns
t_{CRS1}	TXEN high to CRS asserted latency		72		ns
t_{CRS2}	TXEN low to CRS de-asserted latency		72		ns

MII Receive Timing (100Base-TX)

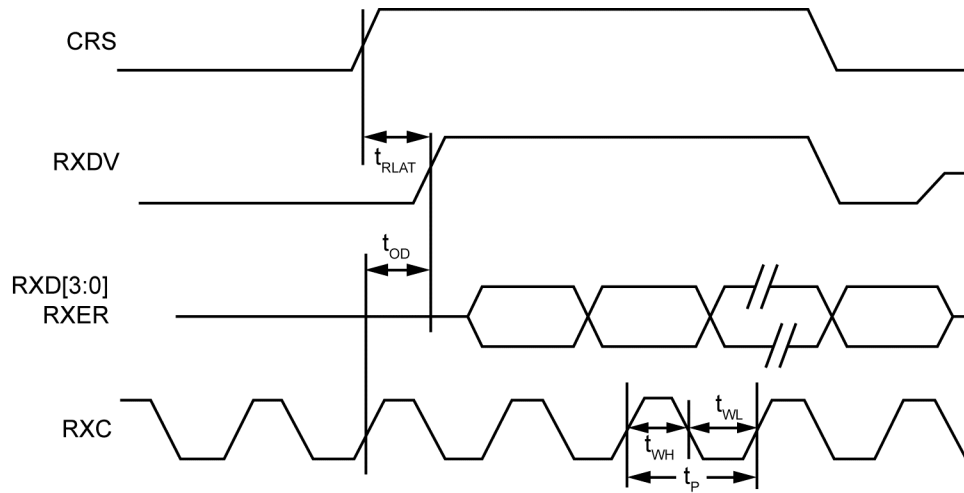

Figure 20. MII Receive Timing (100Base-TX)

Table 20. MII Receive Timing (100Base-TX) Parameters

Timing Parameter	Description	Min.	Typ.	Max.	Unit
t_P	RXC period		40		ns
t_{WL}	RXC pulse width low		20		ns
t_{WH}	RXC pulse width high		20		ns
t_{OD}	(RXDV, RXD[3:0], RXER) output delay from rising edge of RXC		25		ns
t_{RLAT}	CRS to (RXDV, RXD[3:0]) latency		170		ns

RMII Timing

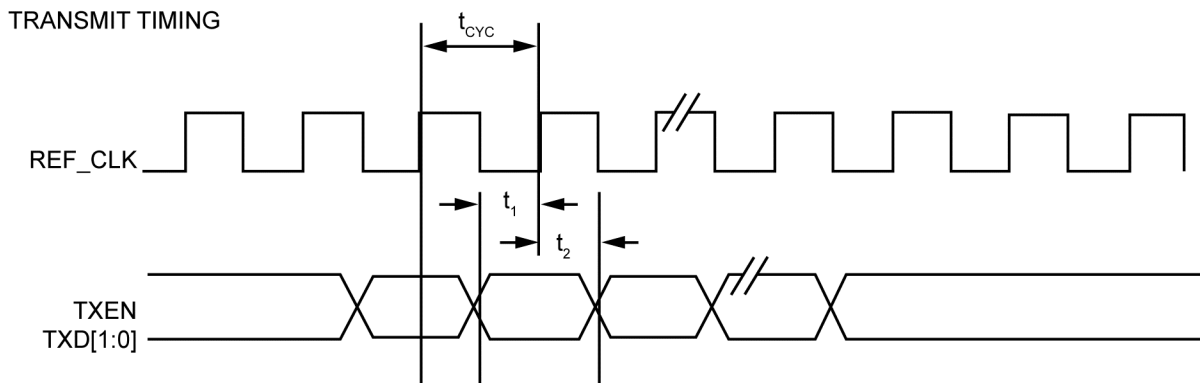

Figure 21. RMII Timing – Data Received from RMII

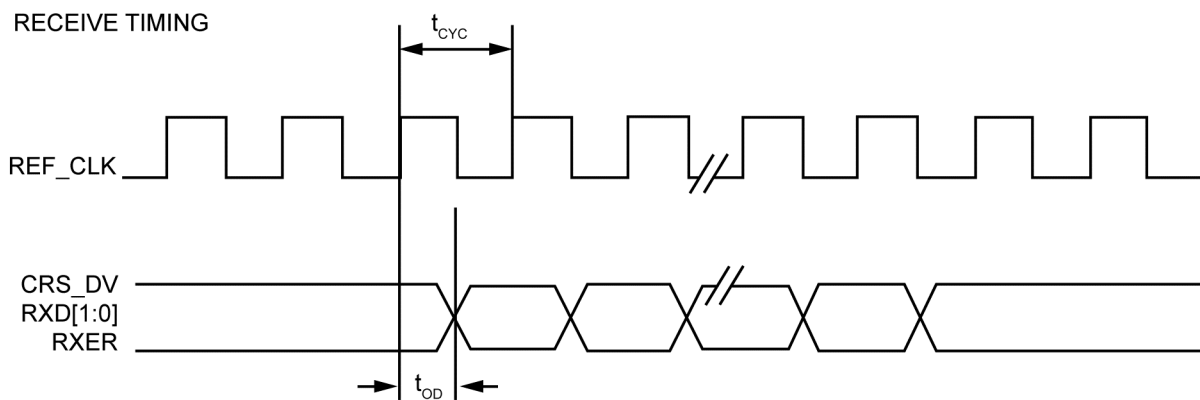

Figure 22. RMII Timing – Data Input to RMII

Table 21. RMII Timing Parameters – KSZ8091RNB (25MHz input to XI pin, 50MHz output from REF_CLK pin)

Timing Parameter	Description	Min.	Typ.	Max.	Unit
t_{cyc}	Clock cycle		20		ns
t_1	Setup time	4			ns
t_2	Hold time	2			ns
t_{OD}	Output delay	7	10	13	ns

Table 22. RMII Timing Parameters – KSZ8091RNB (50MHz input to XI pin)

Timing Parameter	Description	Min.	Typ.	Max.	Unit
t_{cyc}	Clock cycle		20		ns
t_1	Setup time	4			ns
t_2	Hold time	2			ns
t_{OD}	Output delay	8	11	13	ns

Auto-Negotiation Timing

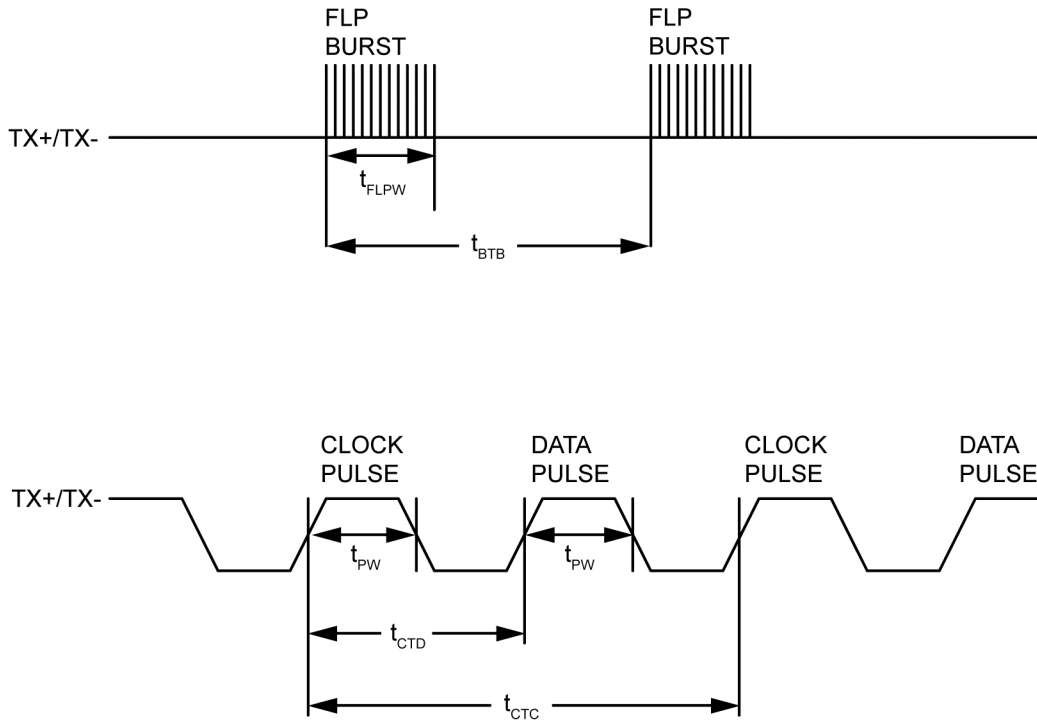

Figure 23. Auto-Negotiation Fast Link Pulse (FLP) Timing

Table 23. Auto-Negotiation Fast Link Pulse (FLP) Timing Parameters

Timing Parameter	Description	Min.	Typ.	Max.	Unit
t_{BTB}	FLP burst to FLP burst	8	16	24	ms
t_{FLPW}	FLP burst width		2		ms
t_{PW}	Clock/Data pulse width		100		ns
t_{CTD}	Clock pulse to data pulse	55.5	64	69.5	μ s
t_{CTC}	Clock pulse to clock pulse	111	128	139	μ s
	Number of clock/data pulses per FLP burst	17		33	

MDC/MDIO Timing

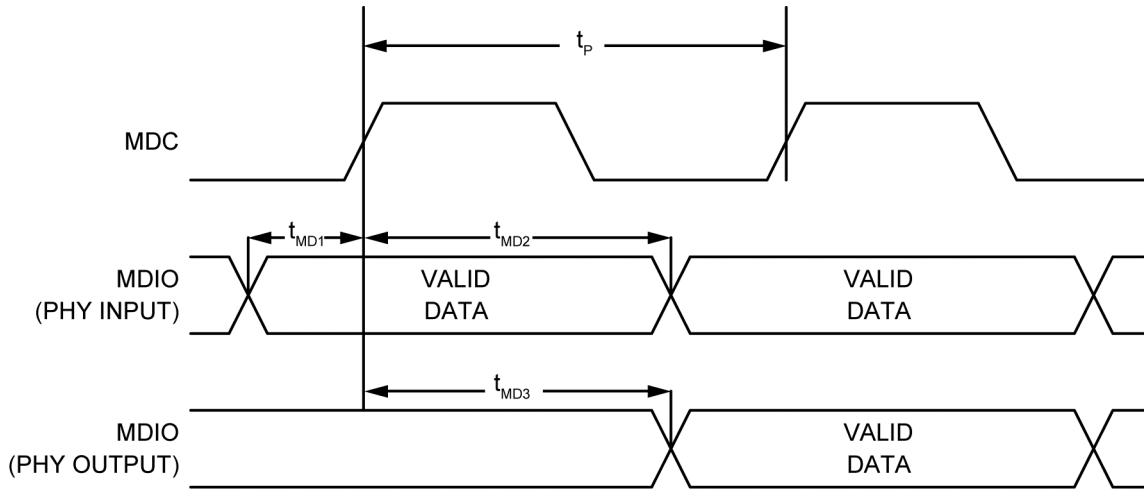

Figure 24. MDC/MDIO Timing

Table 24. MDC/MDIO Timing Parameters

Timing Parameter	Description	Min.	Typ.	Max.	Unit
t_P	MDC period		400		ns
t_{MD1}	MDIO (PHY input) setup to rising edge of MDC	10			ns
t_{MD2}	MDIO (PHY input) hold from rising edge of MDC	4			ns
t_{MD3}	MDIO (PHY output) delay from rising edge of MDC	5			ns

Power-Up/Reset Timing

The KSZ8091MNX/RNB reset timing requirement is summarized in [Figure 25](#) and [Table 25](#).

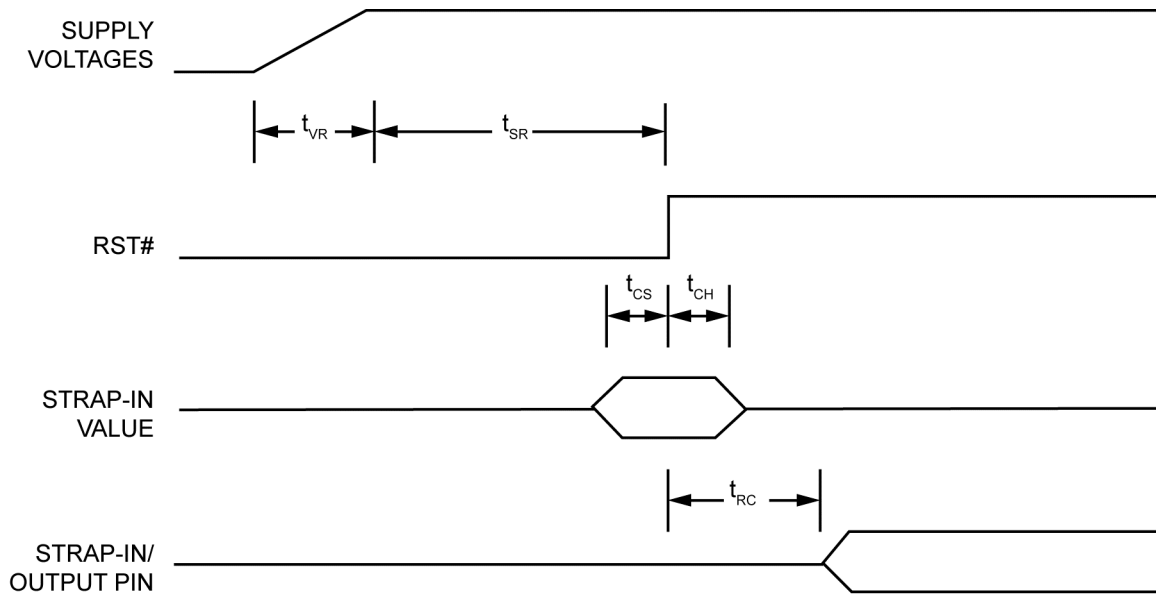

Figure 25. Power-Up/Reset Timing

Table 25. Power-Up/Reset Timing Parameters

Timing Parameter	Description	Min.	Typ.	Max.	Unit
t_{VR}	Supply voltage (V_{DDIO} , $V_{DDA_{3.3}}$) rise time	300			μs
t_{SR}	Stable supply voltage (V_{DDIO} , $V_{DDA_{3.3}}$) to reset high	10			ms
t_{CS}	Configuration setup time	5			ns
t_{CH}	Configuration hold time	5			ns
t_{RC}	Reset to strap-in pin output	6			ns

The supply voltage (V_{DDIO} and $V_{DDA_{3.3}}$) power-up waveform should be monotonic. The 300 μs minimum rise time is from 10% to 90%.

For warm reset, the reset (RST#) pin should be asserted low for a minimum of 500 μs . The strap-in pin values are read and updated at the de-assertion of reset.

After the de-assertion of reset, wait a minimum of 100 μs before starting programming on the MIIM (MDC/MDIO) interface.

Reset Circuit

Figure 26 shows a reset circuit recommended for powering up the KSZ8091MNX/RNB if reset is triggered by the power supply.

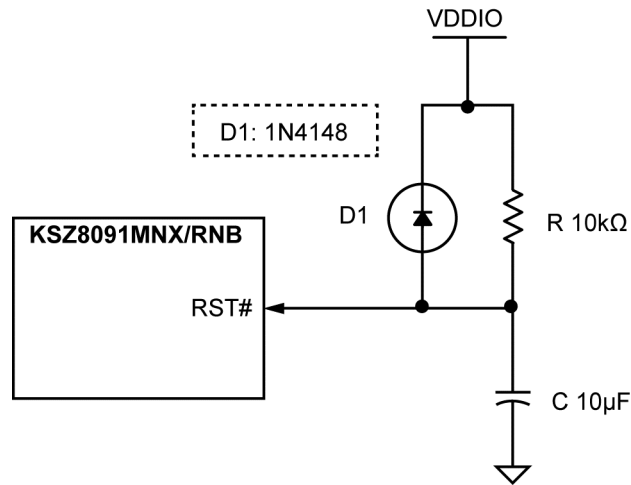

Figure 26. Recommended Reset Circuit

Figure 27 shows a reset circuit recommended for applications where reset is driven by another device (for example, the CPU or an FPGA). At power-on-reset, R, C, and D1 provide the necessary ramp rise time to reset the KSZ8091MNX/RNB device. The RST_OUT_N from the CPU/FPGA provides the warm reset after power-up.

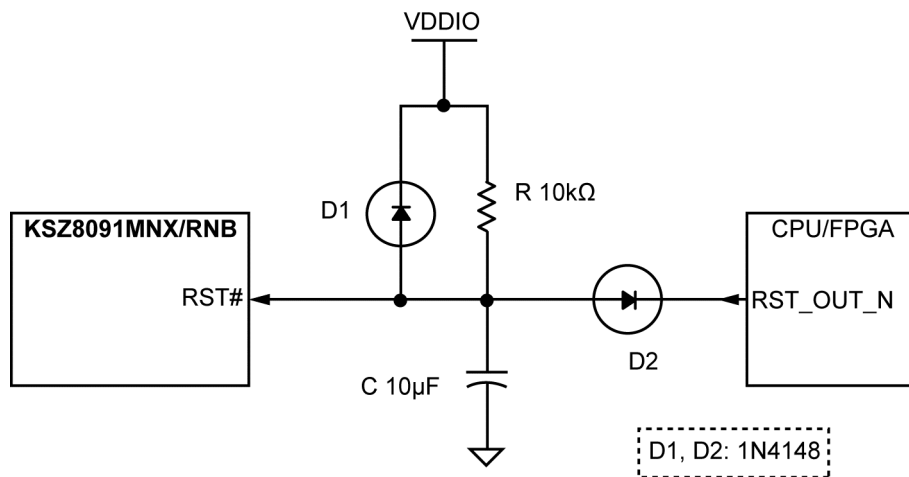

Figure 27. Recommended Reset Circuit for Interfacing with CPU/FPGA Reset Output

Reference Circuits – LED Strap-In Pins

The pull-up, float, and pull-down reference circuits for the LED1/SPEED and LED0/PME_N1/NWAYEN strapping pins are shown in Figure 28 for 3.3V and 2.5V VDDIO.

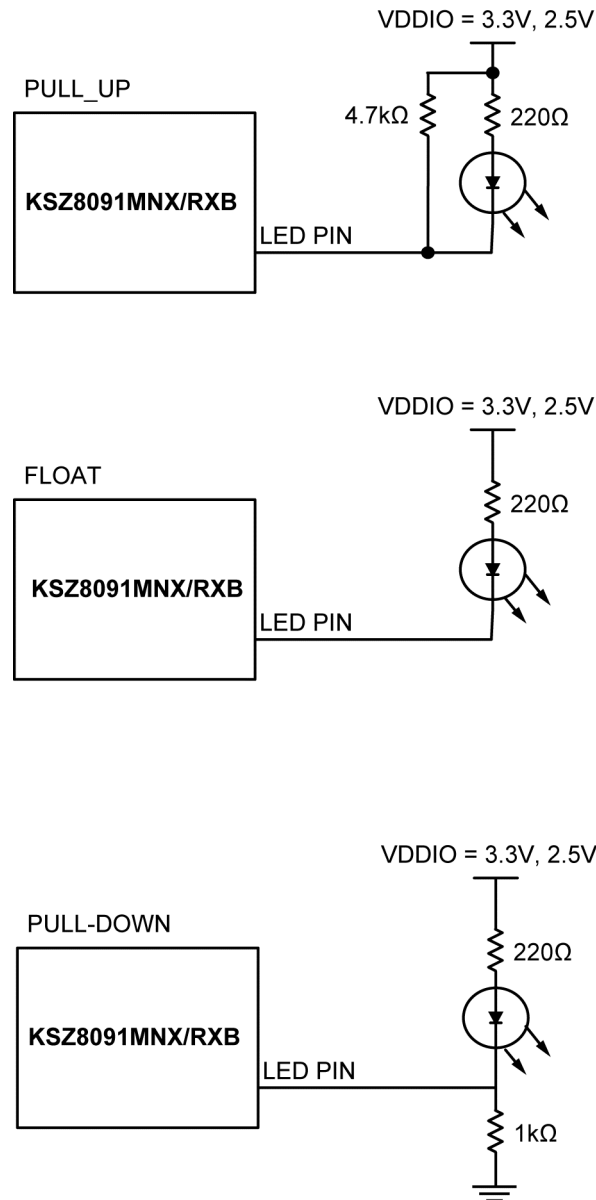

Figure 28. Reference Circuits for LED Strapping Pins

For 1.8V VDDIO, LED indication support is not recommended due to the low voltage. Without the LED indicator, the SPEED and NWAYEN strapping pins are functional with a 4.7kΩ pull-up to 1.8V VDDIO or float for a value of '1', and with a 1.0kΩ pull-down to ground for a value of '0'.

Reference Clock – Connection and Selection

A crystal or external clock source, such as an oscillator, is used to provide the reference clock for the KSZ8091MNX/RNB. For the KSZ8091MNX in all operating modes and for the KSZ8091RNB in RMII – 25MHz Clock Mode, the reference clock is 25 MHz. The reference clock connections to XI (pin 9) and XO (pin 8), and the reference clock selection criteria, are provided in [Figure 29](#) and [Table 26](#).

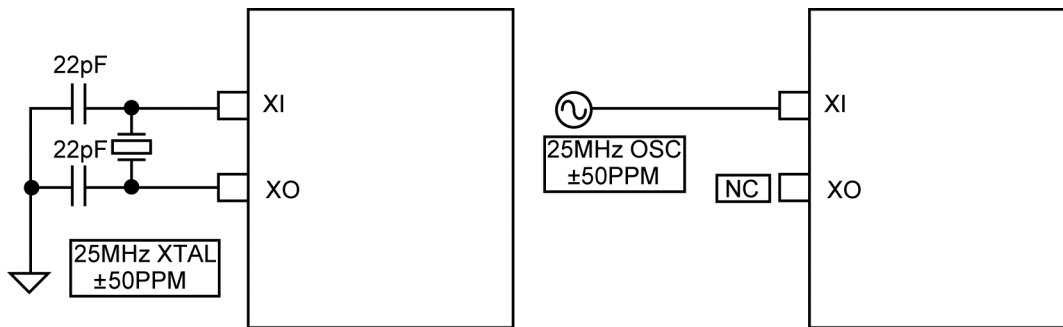

Figure 29. 25MHz Crystal/Oscillator Reference Clock Connection

Table 26. 25MHz Crystal / Reference Clock Selection Criteria

Characteristics	Value	Units
Frequency	25	MHz
Frequency tolerance (max.)	±50	ppm
Crystal series resistance (typ.)	40	Ω
Crystal load capacitance (typ.)	22	pF

For the KSZ8091RNB in RMII – 50MHz clock mode, the reference clock is 50MHz. The reference clock connections to XI (pin 9), and the reference clock selection criteria are provided in [Figure 30](#) and [Table 27](#).

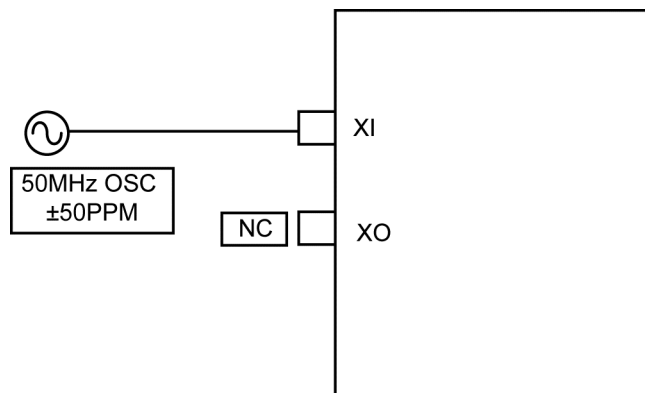

Figure 30. 50MHz Oscillator Reference Clock Connection

Table 27. 50MHz Oscillator / Reference Clock Selection Criteria

Characteristics	Value	Units
Frequency	50	MHz
Frequency tolerance (max.)	±50	ppm

Magnetic – Connection and Selection

A 1:1 isolation transformer is required at the line interface. Use one with integrated common-mode chokes for designs exceeding FCC requirements.

The KSZ8091MNX/RNB design incorporates voltage-mode transmit drivers and on-chip terminations.

With the voltage-mode implementation, the transmit drivers supply the common-mode voltages to the two differential pairs. Therefore, the two transformer center tap pins on the KSZ8091MNX/RNB side should not be connected to any power supply source on the board; instead, the center tap pins should be separated from one another and connected through separate 0.1µF common-mode capacitors to ground. Separation is required because the common-mode voltage is different between transmitting and receiving differential pairs.

Figure 31 shows the typical magnetic interface circuit for the KSZ8091MNX/RNB.

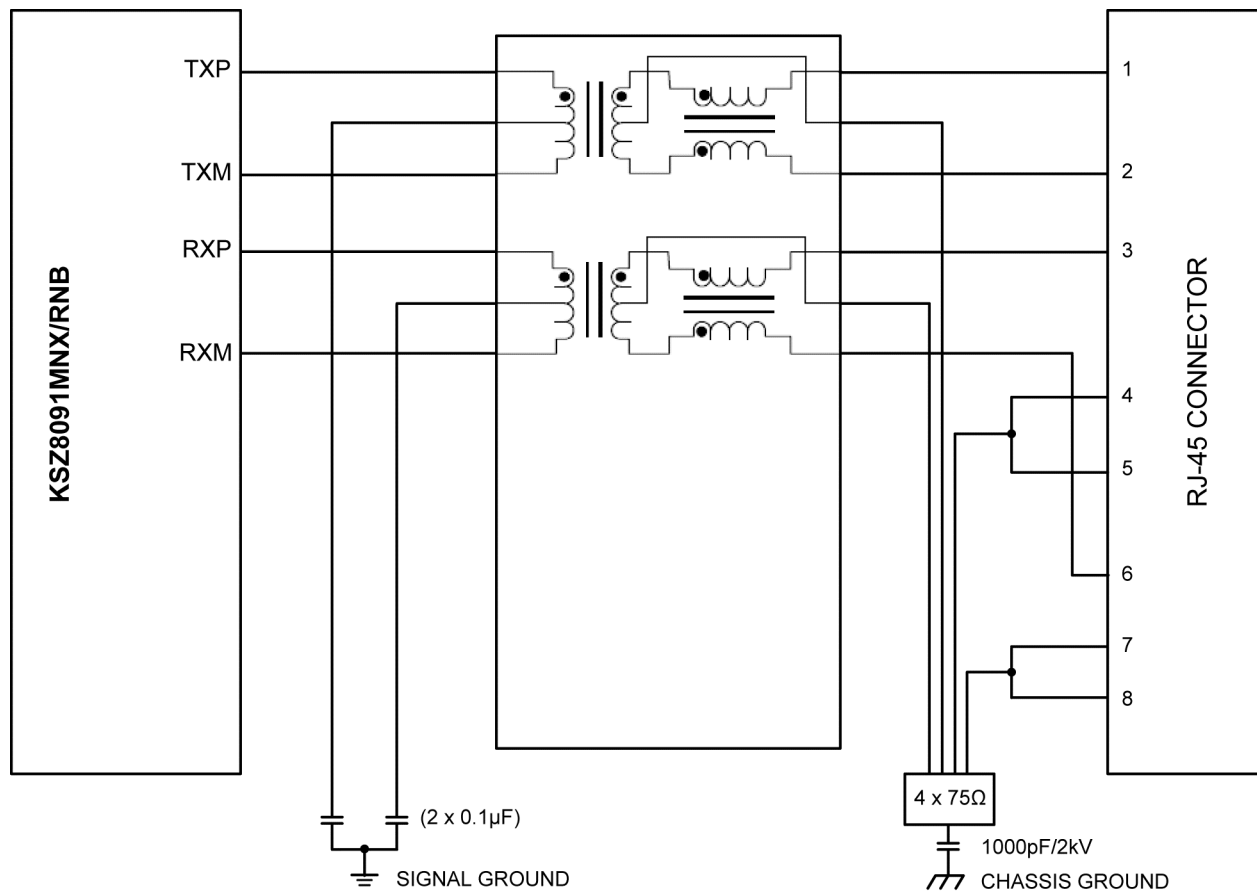

Figure 31. Typical Magnetic Interface Circuit

Table 28 lists recommended magnetic characteristics.

Table 28. Magnetics Selection Criteria

Parameter	Value	Test Condition
Turns ratio	1 CT : 1 CT	
Open-circuit inductance (min.)	350 μ H	100mV, 100kHz, 8mA
Insertion loss (typ.)	-1.1dB	100kHz to 100MHz
HIPOT (min.)	1500Vrms	

Table 29 is a list of compatible single-port magnetics with separated transformer center tap pins on the PHY chip side that can be used with the KSZ8091MNX/RNB.

Table 29. Compatible Single-Port 10/100 Magnetics

Manufacturer	Part Number	Temperature Range	Magnetic + RJ-45
Bel Fuse	S558-5999-U7	0°C to 70°C	No
Bel Fuse	SI-46001-F	0°C to 70°C	Yes
Bel Fuse	SI-50170-F	0°C to 70°C	Yes
Delta	LF8505	0°C to 70°C	No
HALO	HFJ11-2450E	0°C to 70°C	Yes
HALO	TG110-E055N5	-40°C to 85°C	No
LANKom	LF-H41S-1	0°C to 70°C	No
Pulse	H1102	0°C to 70°C	No
Pulse	H1260	0°C to 70°C	No
Pulse	HX1188	-40°C to 85°C	No
Pulse	J00-0014	0°C to 70°C	Yes
Pulse	JX0011D21NL	-40°C to 85°C	Yes
TDK	TLA-6T718A	0°C to 70°C	Yes
Transpower	HB726	0°C to 70°C	No
Würth/Midcom	000-7090-37R-LF1	-40°C to 85°C	No

Recommended Land Pattern

LP # QFN55-32LD-LP-1
 All units are in mm
 Tolerance ± 0.05 if not noted

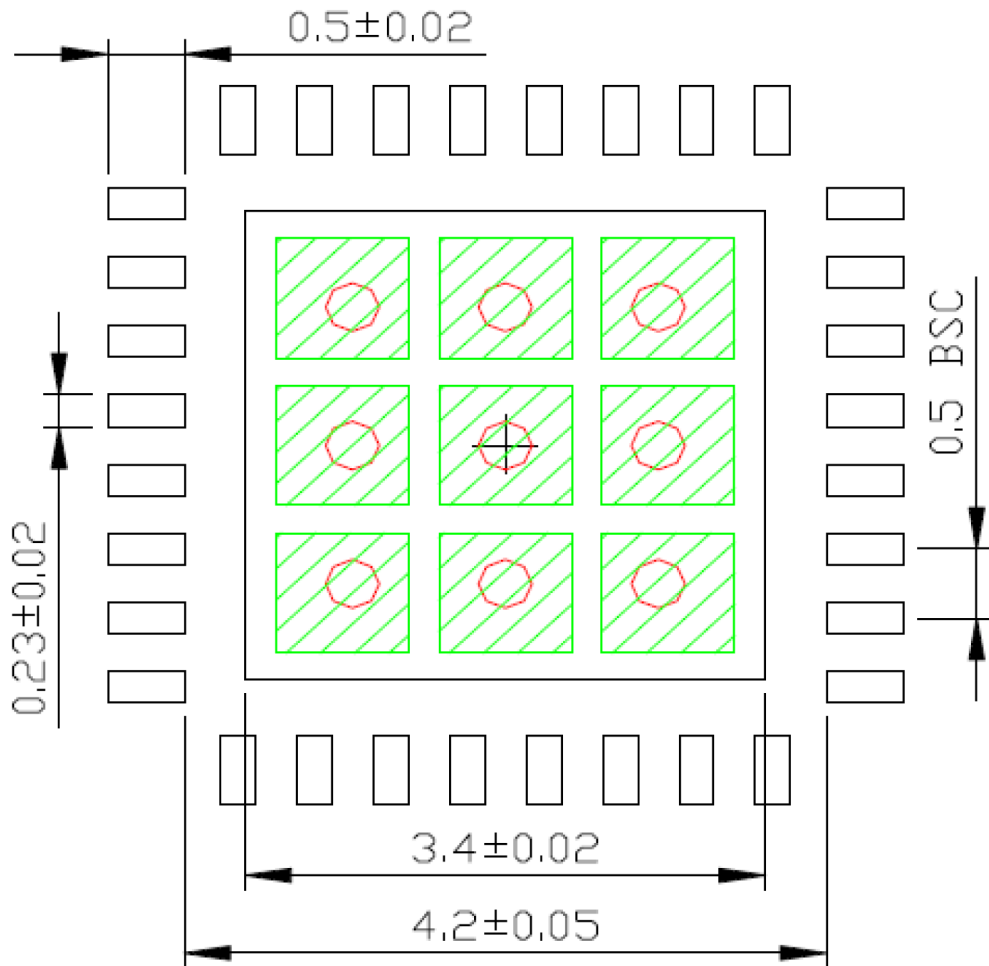
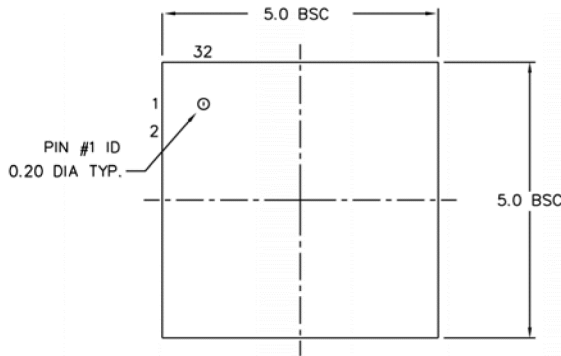

Figure 32. Recommended Land Pattern, 32-Pin (5mm x 5mm) QFN

Red circles indicate thermal vias. They should be 0.350mm in diameter and be connected to the GND plane for maximum thermal performance.

Green rectangles (with shaded area) indicate solder stencil openings on the exposed pad area. They should be 0.87 x 0.87mm in size, 1.07mm pitch.

Package Information⁽¹⁶⁾



TOP VIEW

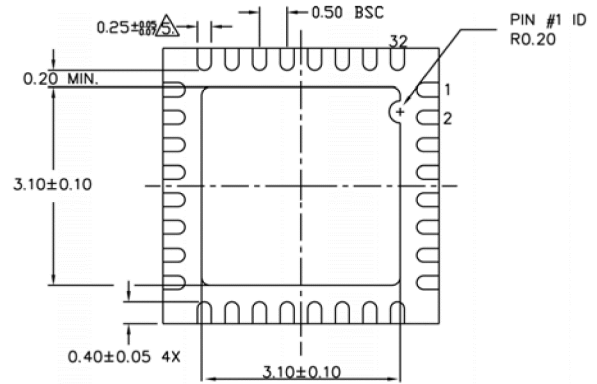

BOTTOM VIEW

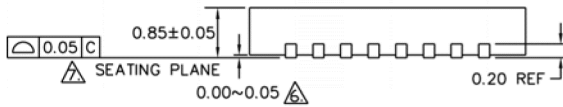

SIDE VIEW

NOTE:

1. ALL DIMENSIONS ARE IN MILLIMETERS.
 2. MAX. PACKAGE WARPAGE IS 0.05 mm.
 3. MAXIMUM ALLOWABLE BURRS IS 0.076 mm IN ALL DIRECTIONS.
 4. PIN #1 ID ON TOP WILL BE LASER/INK MARKED.
- △ DIMENSION APPLIES TO METALIZED TERMINAL AND IS MEASURED BETWEEN 0.20 AND 0.25 mm FROM TERMINAL TIP.
- △ APPLIED ONLY FOR TERMINALS.
- △ APPLIED FOR EXPOSED PAD AND TERMINALS.

32-Pin (5mm x 5mm) QFN

Note:

16. Package information is correct as of the publication date. For updates and most current information, go to www.micrel.com.

MICREL, INC. 2180 FORTUNE DRIVE SAN JOSE, CA 95131 USA
 TEL +1 (408) 944-0800 FAX +1 (408) 474-1000 WEB <http://www.micrel.com>

Micrel makes no representations or warranties with respect to the accuracy or completeness of the information furnished in this data sheet. This information is not intended as a warranty and Micrel does not assume responsibility for its use. Micrel reserves the right to change circuitry, specifications and descriptions at any time without notice. No license, whether express, implied, arising by estoppel or otherwise, to any intellectual property rights is granted by this document. Except as provided in Micrel's terms and conditions of sale for such products, Micrel assumes no liability whatsoever, and Micrel disclaims any express or implied warranty relating to the sale and/or use of Micrel products including liability or warranties relating to fitness for a particular purpose, merchantability, or infringement of any patent, copyright or other intellectual property right.

Micrel Products are not designed or authorized for use as components in life support appliances, devices or systems where malfunction of a product can reasonably be expected to result in personal injury. Life support devices or systems are devices or systems that (a) are intended for surgical implant into the body or (b) support or sustain life, and whose failure to perform can be reasonably expected to result in a significant injury to the user. A Purchaser's use or sale of Micrel Products for use in life support appliances, devices or systems is a Purchaser's own risk and Purchaser agrees to fully indemnify Micrel for any damages resulting from such use or sale.

Компания «Life Electronics» занимается поставками электронных компонентов импортного и отечественного производства от производителей и со складов крупных дистрибьюторов Европы, Америки и Азии.

С конца 2013 года компания активно расширяет линейку поставок компонентов по направлению коаксиальный кабель, кварцевые генераторы и конденсаторы (керамические, пленочные, электролитические), за счёт заключения дистрибьюторских договоров

Мы предлагаем:

- Конкурентоспособные цены и скидки постоянным клиентам.
- Специальные условия для постоянных клиентов.
- Подбор аналогов.
- Поставку компонентов в любых объемах, удовлетворяющих вашим потребностям.
- Приемлемые сроки поставки, возможна ускоренная поставка.
- Доставку товара в любую точку России и стран СНГ.
- Комплексную поставку.
- Работу по проектам и поставку образцов.
- Формирование склада под заказчика.
- Сертификаты соответствия на поставляемую продукцию (по желанию клиента).
- Тестирование поставляемой продукции.
- Поставку компонентов, требующих военную и космическую приемку.
- Входной контроль качества.
- Наличие сертификата ISO.

В составе нашей компании организован Конструкторский отдел, призванный помогать разработчикам, и инженерам.

Конструкторский отдел помогает осуществить:

- Регистрацию проекта у производителя компонентов.
- Техническую поддержку проекта.
- Защиту от снятия компонента с производства.
- Оценку стоимости проекта по компонентам.
- Изготовление тестовой платы монтаж и пусконаладочные работы.



Тел: +7 (812) 336 43 04 (многоканальный)

Email: org@lifeelectronics.ru