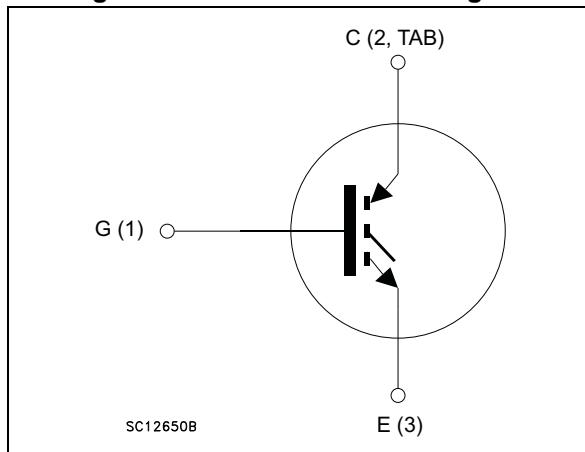

Figure 1. Internal schematic diagram



## Features

- Maximum junction temperature:  $T_J = 175\text{ }^\circ\text{C}$
- High speed switching series
- Minimized tail current
- $V_{CE(sat)} = 1.6\text{ V (typ.) @ } I_C = 60\text{ A}$
- Tight parameters distribution
- Safe paralleling
- Low thermal resistance

## Applications

- Photovoltaic inverters
- High frequency converters

## Description

These are IGBT devices developed using an advanced proprietary trench gate and field-stop structure. The devices are part of the new HB series of IGBTs which represent an optimum compromise between conduction and switching loss to maximize the efficiency of any frequency converter. Furthermore, a slightly positive  $V_{CE(sat)}$  temperature coefficient and very tight parameter distribution result in safer paralleling operation.

Table 1. Device summary

Order code	Marking	Package	Packing
STGW60H65FB	GW60H65FB	TO-247	Tube
STGWT60H65FB	GWT60H65FB	TO-3P	Tube

# Contents

<b>1</b>	<b>Electrical ratings</b> .....	<b>3</b>
<b>2</b>	<b>Electrical characteristics</b> .....	<b>4</b>
2.1	Electrical characteristics (curve) .....	6
<b>3</b>	<b>Test circuits</b> .....	<b>10</b>
<b>4</b>	<b>Package information</b> .....	<b>11</b>
4.1	TO-247 package information .....	11
4.2	TO-3P package information .....	13
<b>5</b>	<b>Revision history</b> .....	<b>15</b>

# 1 Electrical ratings

**Table 2. Absolute maximum ratings**

Symbol	Parameter	Value	Unit
$V_{CES}$	Collector-emitter voltage ( $V_{GE} = 0$ )	650	V
$I_C$	Continuous collector current at $T_C = 25\text{ °C}$	80 <sup>(1)</sup>	A
	Continuous collector current at $T_C = 100\text{ °C}$	60	
$I_{CP}$ <sup>(2)</sup>	Pulsed collector current	240	A
$V_{GE}$	Gate-emitter voltage	$\pm 20$	V
$P_{TOT}$	Total dissipation at $T_C = 25\text{ °C}$	375	W
$T_{stg}$	Storage temperature	-55 to 150	°C
$T_j$	Operating junction temperature	-55 to 175	

1. Current level is limited by bond wires.
2. Pulse width limited by maximum junction temperature.

**Table 3. Thermal data**

Symbol	Parameter	Value	Unit
$R_{thj-C}$	Thermal resistance junction-case	0.4	°C/W
$R_{thj-A}$	Thermal resistance junction-ambient	50	

## 2 Electrical characteristics

$T_J = 25\text{ °C}$  unless otherwise specified.

**Table 4. Static characteristics**

Symbol	Parameter	Test conditions	Min.	Typ.	Max.	Unit
$V_{(BR)CES}$	Collector-emitter breakdown voltage ( $V_{GE} = 0$ )	$I_C = 2\text{ mA}$	650			V
$V_{CE(sat)}$	Collector-emitter saturation voltage	$V_{GE} = 15\text{ V}, I_C = 60\text{ A}$		1.60	2.0	V
		$V_{GE} = 15\text{ V}, I_C = 60\text{ A}$ $T_J = 125\text{ °C}$		1.75		
		$V_{GE} = 15\text{ V}, I_C = 60\text{ A}$ $T_J = 175\text{ °C}$		1.85		
$V_{GE(th)}$	Gate threshold voltage	$V_{CE} = V_{GE}, I_C = 1\text{ mA}$	5	6	7	V
$I_{CES}$	Collector cut-off current ( $V_{GE} = 0$ )	$V_{CE} = 650\text{ V}$			25	$\mu\text{A}$
$I_{GES}$	Gate-emitter leakage current ( $V_{CE} = 0$ )	$V_{GE} = \pm 20\text{ V}$			$\pm 250$	nA

**Table 5. Dynamic characteristics**

Symbol	Parameter	Test conditions	Min.	Typ.	Max.	Unit
$C_{ies}$	Input capacitance	$V_{CE} = 25\text{ V}, f = 1\text{ MHz},$ $V_{GE} = 0$	-	7792	-	pF
$C_{oes}$	Output capacitance		-	262	-	
$C_{res}$	Reverse transfer capacitance		-	158	-	
$Q_g$	Total gate charge	$V_{CC} = 520\text{ V}, I_C = 60\text{ A},$ $V_{GE} = 15\text{ V},$ see <a href="#">Figure 23</a>	-	306	-	nC
$Q_{ge}$	Gate-emitter charge		-	126	-	
$Q_{gc}$	Gate-collector charge		-	58	-	

Table 6. Switching characteristics (inductive load)

Symbol	Parameter	Test conditions	Min.	Typ.	Max.	Unit	
$t_{d(on)}$	Turn-on delay time	$V_{CE} = 400\text{ V}$ , $I_C = 60\text{ A}$ , $R_G = 10\ \Omega$ , $V_{GE} = 15\text{ V}$ , see <a href="#">Figure 22</a>	-	66		ns	
$t_r$	Current rise time		-	38	-	ns	
$(di/dt)_{on}$	Turn-on current slope		-	1216		A/ $\mu$ s	
$t_{d(off)}$	Turn-off delay time				210		ns
$t_f$	Current fall time		-	20	-	ns	
$E_{on}^{(1)}$	Turn-on switching loss		-	1590	-	$\mu$ J	
$E_{off}^{(2)}$	Turn-off switching loss		-	900	-	$\mu$ J	
$E_{ts}$	Total switching loss	-	2490	-	$\mu$ J		
$t_{d(on)}$	Turn-on delay time	$V_{CE} = 400\text{ V}$ , $I_C = 60\text{ A}$ , $R_G = 10\ \Omega$ , $V_{GE} = 15\text{ V}$ , $T_J = 175\text{ }^\circ\text{C}$ , see <a href="#">Figure 22</a>	-	59		ns	
$t_r$	Current rise time		-	40	-	ns	
$(di/dt)_{on}$	Turn-on current slope		-	1230		A/ $\mu$ s	
$t_{d(off)}$	Turn-off delay time				242		ns
$t_f$	Current fall time		-	147	-	ns	
$E_{on}^{(1)}$	Turn-on switching loss		-	2860	-	$\mu$ J	
$E_{off}^{(2)}$	Turn-off switching loss		-	1255	-	$\mu$ J	
$E_{ts}$	Total switching loss	-	4115	-	$\mu$ J		

1. Energy loss includes reverse recovery of the external diode. The diode is the same as the co-packaged STGW60H65DFB.
2. Turn-off loss also includes the tail of the collector current.

## 2.1 Electrical characteristics (curve)

Figure 2. Output characteristics ( $T_J = 25^\circ\text{C}$ )

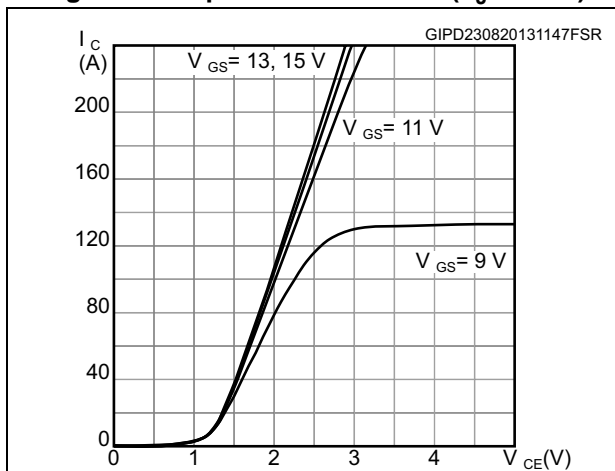

Figure 3. Output characteristics ( $T_J = 175^\circ\text{C}$ )

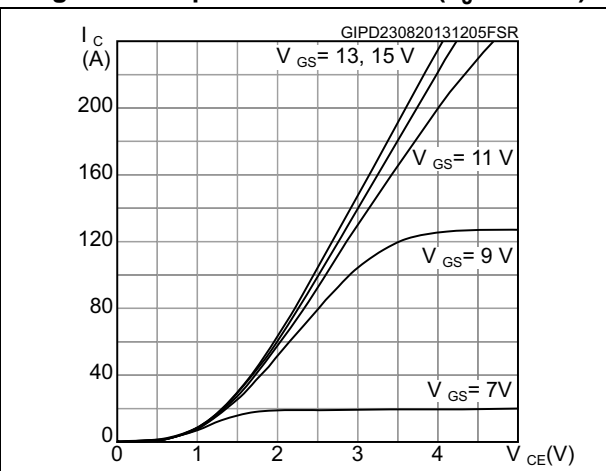

Figure 4. Transfer characteristics

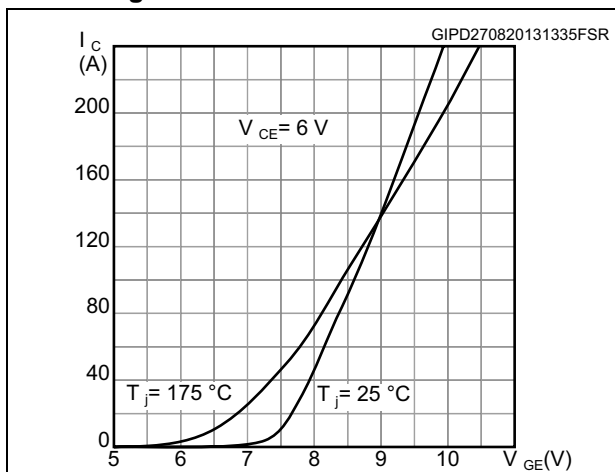

Figure 5. Collector current vs. case temperature

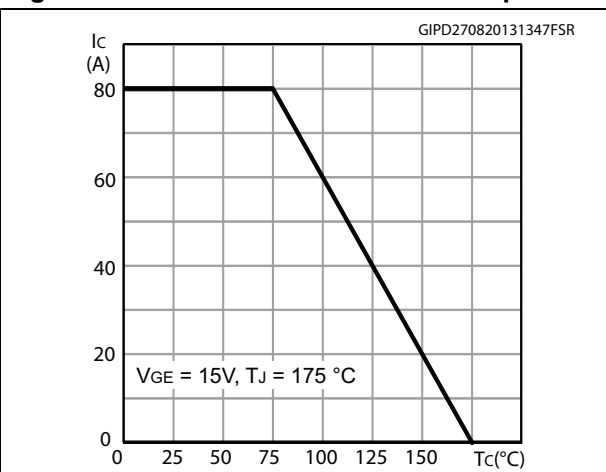

Figure 6. Power dissipation vs. case temperature

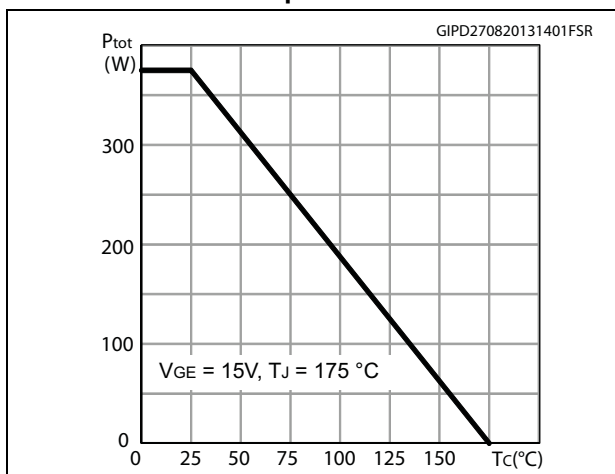

Figure 7.  $V_{CE(sat)}$  vs. junction temperature

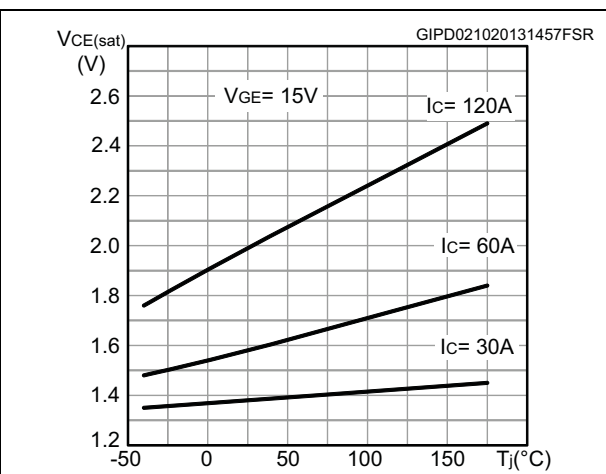

Figure 8.  $V_{CE(sat)}$  vs. collector current

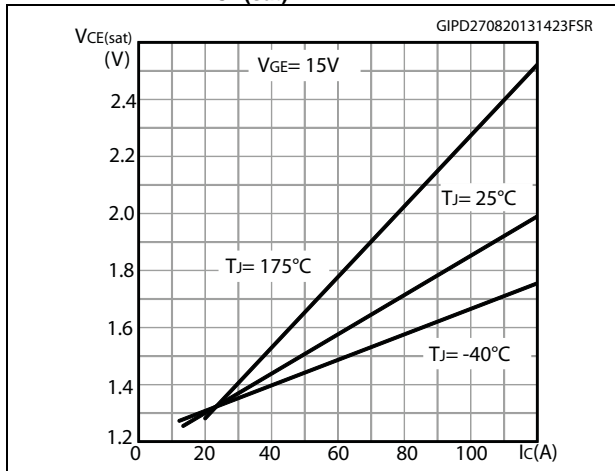

Figure 9. Forward bias safe operating area

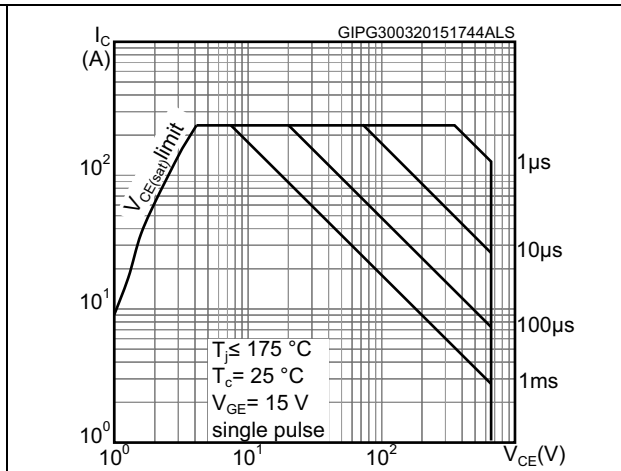

Figure 10. Normalized  $V_{(BR)CES}$  vs. junction temperature

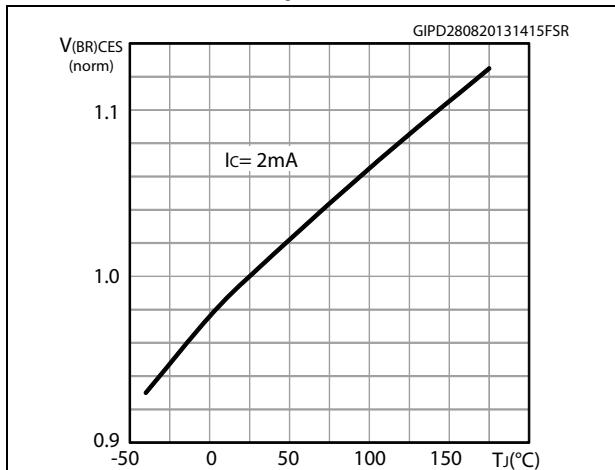

Figure 11. Normalized  $V_{GE(th)}$  vs. junction temperature

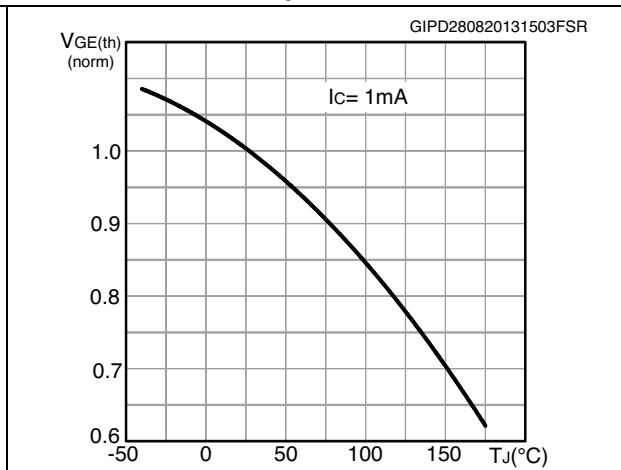

Figure 12. Gate charge vs. gate-emitter voltage

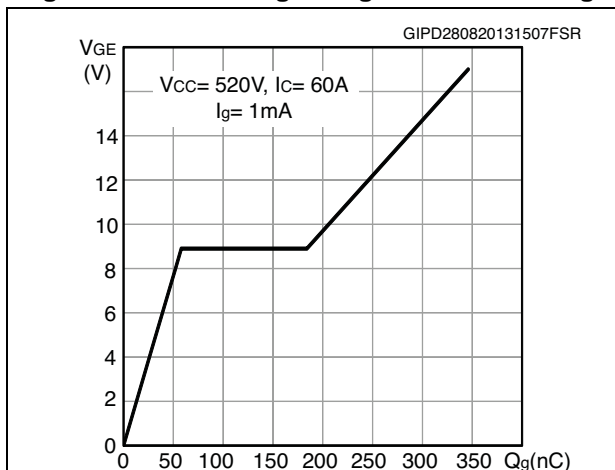

Figure 13. Switching loss vs temperature

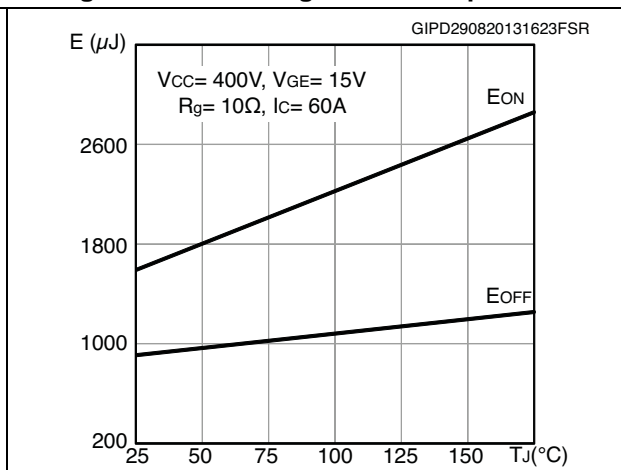

Figure 14. Switching loss vs gate resistance

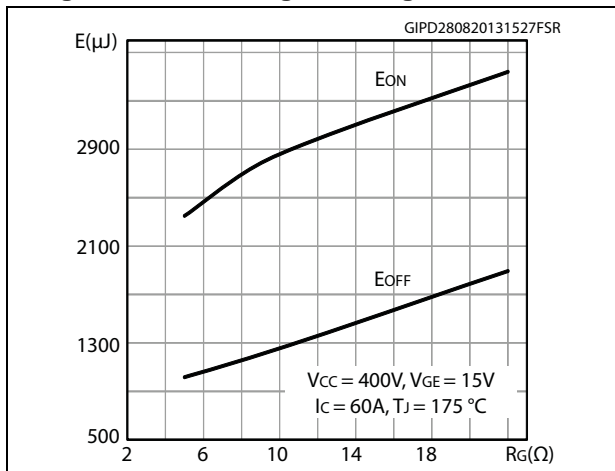

Figure 15. Switching loss vs collector current

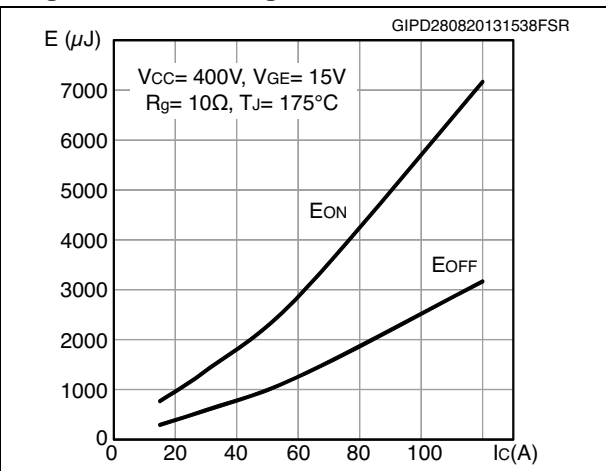

Figure 16. Switching loss vs collector emitter voltage

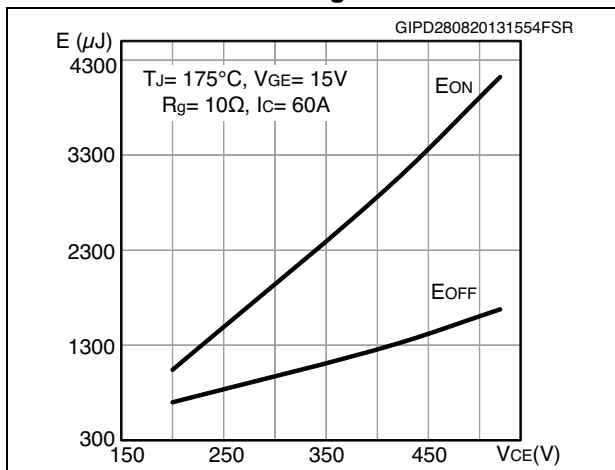

Figure 17. Switching times vs collector current

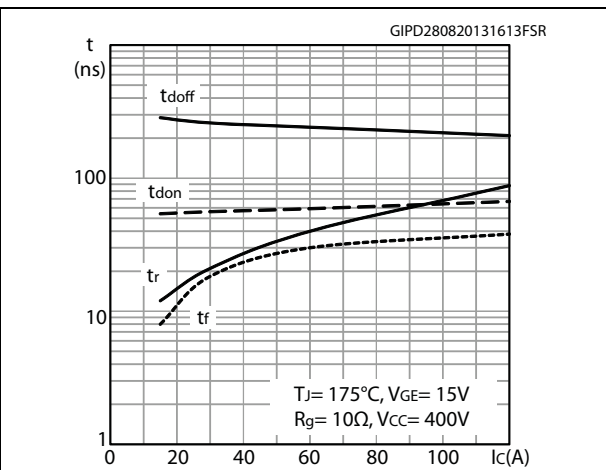

Figure 18. Switching times vs gate resistance

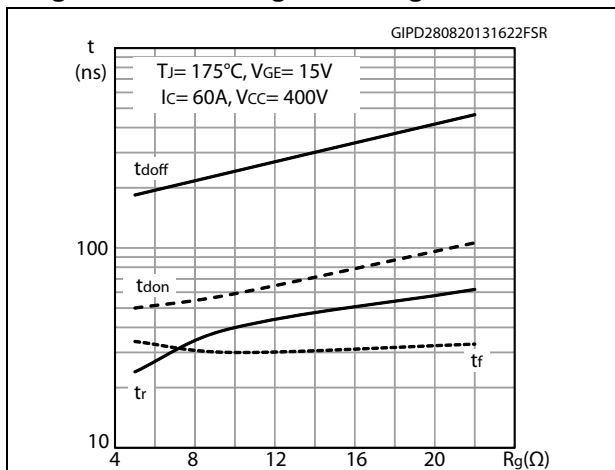

Figure 19. Capacitance variations

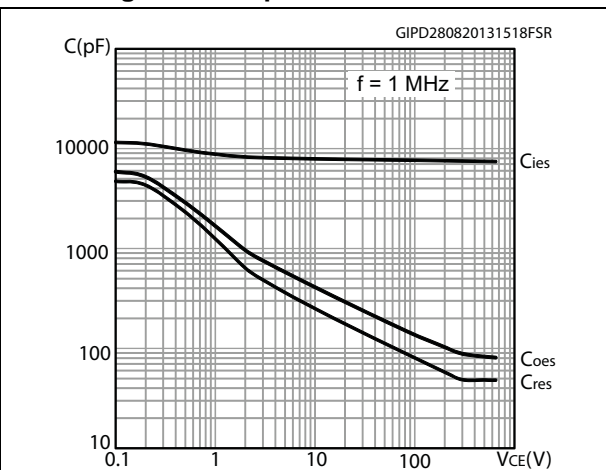



Figure 20. Collector current vs. switching frequency

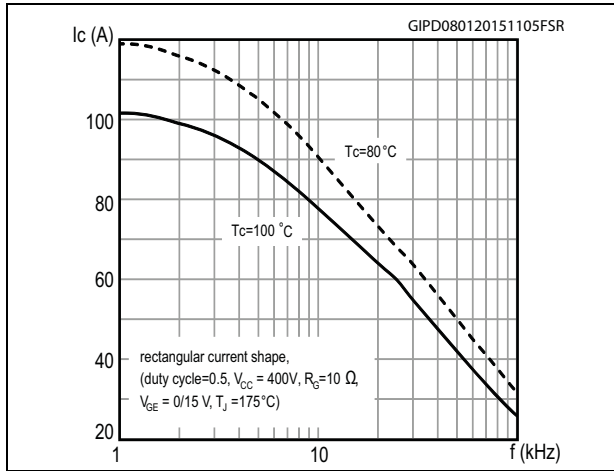
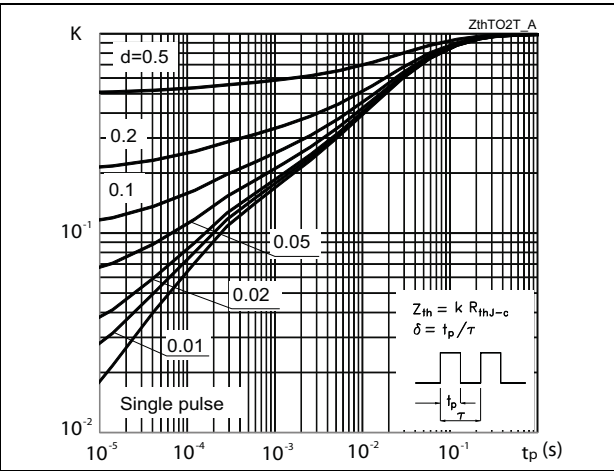

Figure 21. Thermal impedance



### 3 Test circuits

Figure 22. Test circuit for inductive load switching

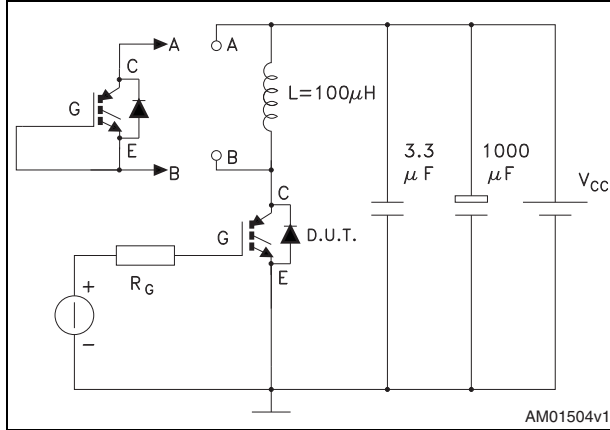

Figure 23. Gate charge test circuit

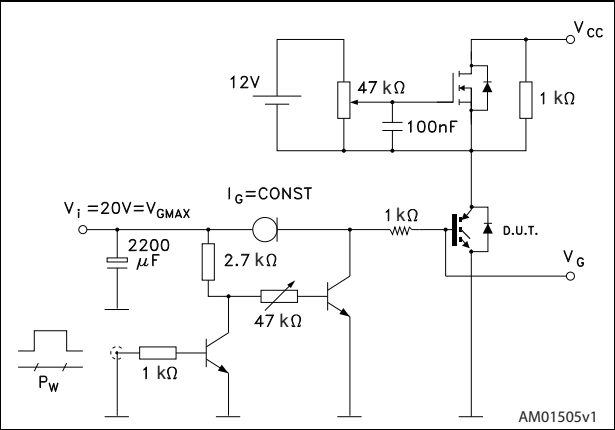
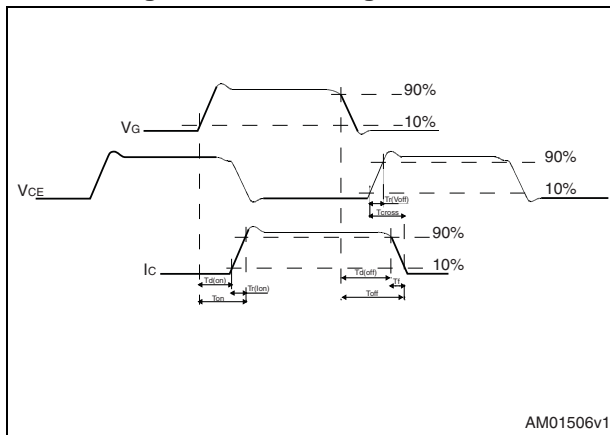

Figure 24. Switching waveform



## 4 Package information

In order to meet environmental requirements, ST offers these devices in different grades of ECOPACK® packages, depending on their level of environmental compliance. ECOPACK® specifications, grade definitions and product status are available at: [www.st.com](http://www.st.com). ECOPACK is an ST trademark.

### 4.1 TO-247 package information

Figure 25. TO-247 package outline

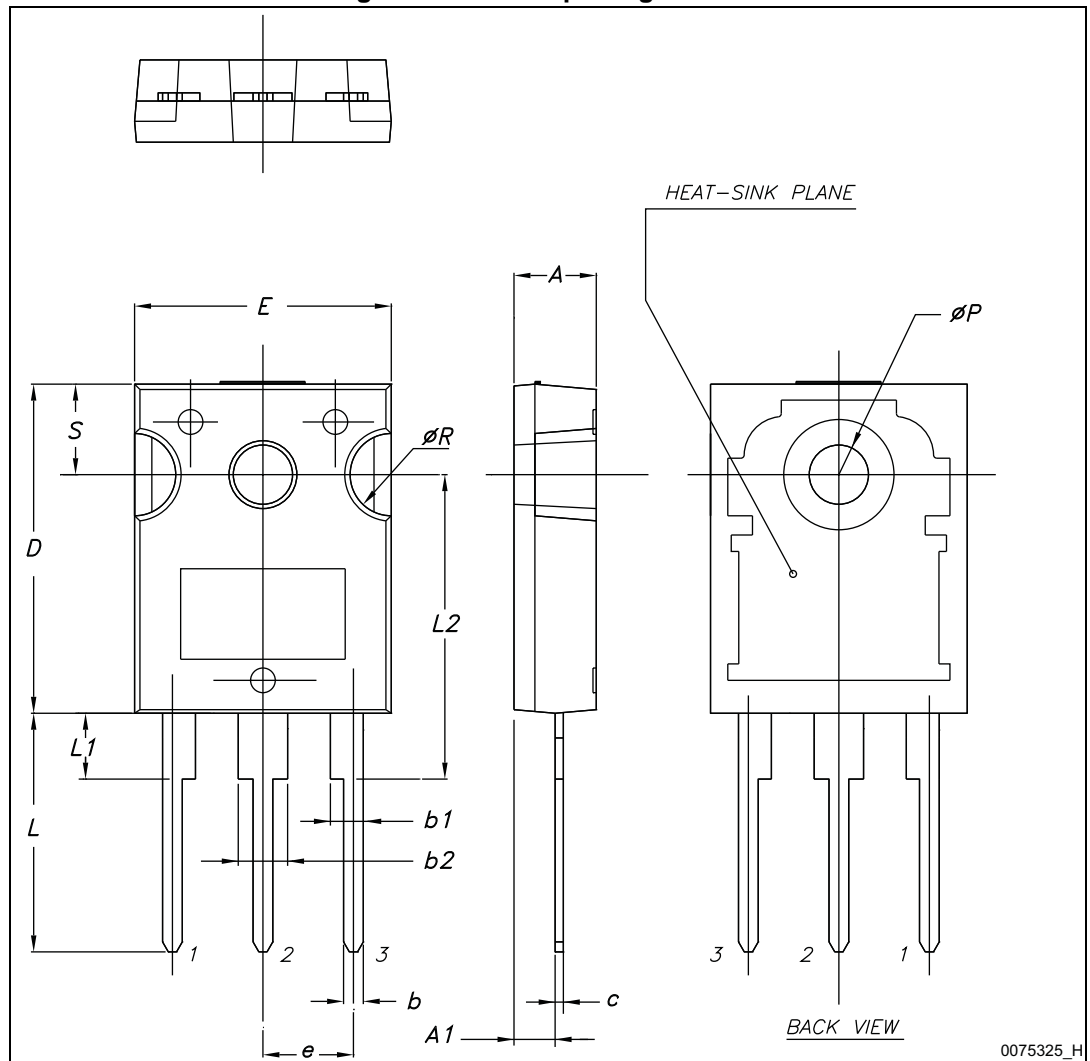
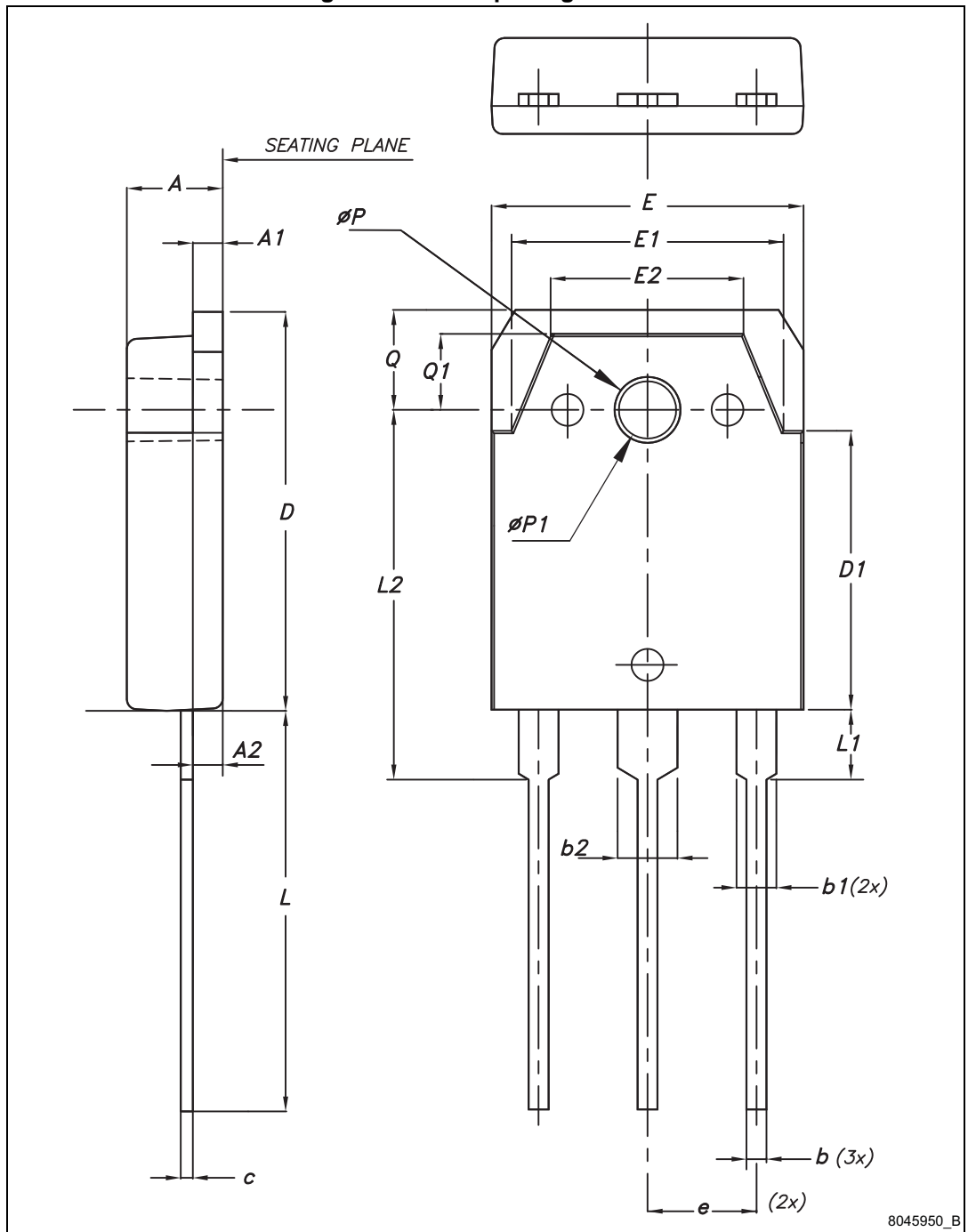

Table 7. TO-247 mechanical data

Dim.	mm.		
	Min.	Typ.	Max.
A	4.85		5.15
A1	2.20		2.60
b	1.0		1.40
b1	2.0		2.40
b2	3.0		3.40
c	0.40		0.80
D	19.85		20.15
E	15.45		15.75
e	5.30	5.45	5.60
L	14.20		14.80
L1	3.70		4.30
L2		18.50	
ØP	3.55		3.65
ØR	4.50		5.50
S	5.30	5.50	5.70

### 4.2 TO-3P package information

Figure 26. TO-3P package outline



8045950\_B

Table 8. TO-3P mechanical data

Dim.	mm		
	Min.	Typ.	Max.
A	4.60	4.80	5
A1	1.45	1.50	1.65
A2	1.20	1.40	1.60
b	0.80	1.00	1.20
b1	1.80	2.00	2.20
b2	2.80	3.00	3.20
c	0.55	0.60	0.75
D	19.70	19.90	20.10
D1	13.70	13.90	14.10
E	15.40	15.60	15.80
E1	13.40	13.60	13.80
E2	9.40	9.60	9.90
e	5.15	5.45	5.75
L	19.80	20	20.20
L1	3.30	3.50	3.70
L2	18.20	18.40	18.60
øP	3.30	3.40	3.50
øP1	3.10	3.20	3.30
Q	4.80	5	5.20
Q1	3.60	3.80	4

## 5 Revision history

**Table 9. Document revision history**

Date	Revision	Changes
30-Aug-2013	1	Initial release.
28-Feb-2014	2	Updated title and features in cover page.
09-Jan-2015	3	Updated features in cover page, <a href="#">Table 2: Absolute maximum ratings</a> , <a href="#">Table 4: Static characteristics</a> and <a href="#">Table 6: Switching characteristics (inductive load)</a> . Updated <a href="#">Figure 5: Collector current vs. case temperature</a> , <a href="#">Figure 6: Power dissipation vs. case temperature</a> , <a href="#">Figure 8: <math>V_{CE(sat)}</math> vs. collector current</a> , <a href="#">Figure 17: Switching times vs collector current</a> , <a href="#">Figure 18: Switching times vs gate resistance</a> and <a href="#">Figure 19: Capacitance variations</a> . Added <a href="#">Figure 20: Collector current vs. switching frequency</a> . Updated <a href="#">Section 4: Package information</a> . Minor text changes.
01-Apr-2015	4	Text edits throughout document Updated <a href="#">Table 2: Absolute maximum ratings</a> Updated <a href="#">Table 4: Static characteristics</a> Updated <a href="#">Table 6: Switching characteristics (inductive load)</a> Updated <a href="#">Section 2.1: Electrical characteristics (curve)</a> .

**IMPORTANT NOTICE – PLEASE READ CAREFULLY**

STMicroelectronics NV and its subsidiaries ("ST") reserve the right to make changes, corrections, enhancements, modifications, and improvements to ST products and/or to this document at any time without notice. Purchasers should obtain the latest relevant information on ST products before placing orders. ST products are sold pursuant to ST's terms and conditions of sale in place at the time of order acknowledgement.

Purchasers are solely responsible for the choice, selection, and use of ST products and ST assumes no liability for application assistance or the design of Purchasers' products.

No license, express or implied, to any intellectual property right is granted by ST herein.

Resale of ST products with provisions different from the information set forth herein shall void any warranty granted by ST for such product.

ST and the ST logo are trademarks of ST. All other product or service names are the property of their respective owners.

Information in this document supersedes and replaces information previously supplied in any prior versions of this document.

© 2015 STMicroelectronics – All rights reserved



Компания «Life Electronics» занимается поставками электронных компонентов импортного и отечественного производства от производителей и со складов крупных дистрибьюторов Европы, Америки и Азии.

С конца 2013 года компания активно расширяет линейку поставок компонентов по направлению коаксиальный кабель, кварцевые генераторы и конденсаторы (керамические, пленочные, электролитические), за счёт заключения дистрибьюторских договоров

Мы предлагаем:

- Конкурентоспособные цены и скидки постоянным клиентам.
- Специальные условия для постоянных клиентов.
- Подбор аналогов.
- Поставку компонентов в любых объемах, удовлетворяющих вашим потребностям.
- Приемлемые сроки поставки, возможна ускоренная поставка.
- Доставку товара в любую точку России и стран СНГ.
- Комплексную поставку.
- Работу по проектам и поставку образцов.
- Формирование склада под заказчика.
- Сертификаты соответствия на поставляемую продукцию (по желанию клиента).
- Тестирование поставляемой продукции.
- Поставку компонентов, требующих военную и космическую приемку.
- Входной контроль качества.
- Наличие сертификата ISO.

В составе нашей компании организован Конструкторский отдел, призванный помогать разработчикам, и инженерам.

Конструкторский отдел помогает осуществить:

- Регистрацию проекта у производителя компонентов.
- Техническую поддержку проекта.
- Защиту от снятия компонента с производства.
- Оценку стоимости проекта по компонентам.
- Изготовление тестовой платы монтаж и пусконаладочные работы.



Тел: +7 (812) 336 43 04 (многоканальный)  
Email: org@lifeelectronics.ru