

PLW5630CB Series 5630

Mid Power LED

Product Datasheet



Description

Plessey PLW5630CB SMT LEDs are designed for optical indicators, indoor displays, automotive lighting, backlights for switches/symbols/LCD, tubular lighting and other general lighting applications and the light is emitted close to a Lambertian distribution. The LEDs are packed in reels containing 3000 pieces; each individual reel will be shipped in single intensity and colour bin, to provide close uniformity.

Features

- 5630 footprint (5.7x3.0x0.8mm)
- High reliability PLCC-2 packaging
- Diffused pale yellow resin
- 120 degree wide viewing angle

Applications

- Tubular Lighting
- Instrument panel backlighting
- Illumination symbols
- Automotive lighting
- General lighting

Variant	Colour	CCT (K)	
		Min.	Max.
PLW5630CB-2700	Warm White 2700K	2600	2800
PLW5630CB-3000	Warm White 3000K	2800	3100
PLW5630CB-3400	Warm White 3400K	3250	3650
PLW5630CB-4000	Neutral White 4000K	3800	4250
PLW5630CB-5000	Cool White 5000K	4750	5300
PLW5630CB-6500	Cool White 6500K	6000	7000

Absolute Maximum Ratings

$T_A = +25^\circ\text{C}$ unless otherwise stated

Parameter	Symbol	Min.	Max.	Unit
DC Forward Current	I_F	-	180	mA
Peak Pulse Forward Current ^[1]	I_{FP}	-	200	mA
Power Dissipation	P_D	-	612	mW
Storage Temperature	T_{stg}	-40	+100	°C
Junction Temperature	T_J	-	+115	°C

^[1] Pulse width 0.1ms, duty cycle $\leq 10\%$

Electro-optical Characteristics

$T_A = +25^\circ\text{C}$ unless otherwise stated

Parameter	Symbol	Condition	Min.	Typ.	Max.	Unit
Forward Voltage	V_F	$I_F = 150 \text{ mA}$	2.8	-	3.4	V
Reverse Current	I_R	$V_R = 5 \text{ V}$	-	-	10	μA
Colour Rendering Index ^[1]	CRI	$I_F = 150 \text{ mA}$	90	-	-	%
Thermal Resistance	R_θ		-	30	-	K/W
Half-Intensity Angle	$2\theta_{1/2}$	$I_F = 150 \text{ mA}$	-	120	-	deg

^[1] Tolerance $\pm 2\%$

Recommended Operating Conditions

In typical applications, for optimum LED performance

Parameter	Symbol	Min.	Max.	Unit
Operating Ambient Temperature	V_F	2.8	3.4	°C

Ordering Information

Name	Order Code	LF Min.	VF Max.
PLW5630CB-2700	PLW5630CBW27000	3A	V1 – V6
PLW5630CB-3000	PLW5630CBW30000		
PLW5630CB-3400	PLW5630CBW34000		
PLW5630CB-4000	PLW5630CBN40000	4A	
PLW5630CB-5000	PLW5630CBC50000		
PLW5630CB-6500	PLW5630CBC65000		

Intensity Bin Groups

$I_F = 150\text{mA}$, $T_A = +25^\circ\text{C}$, unless otherwise stated

Group	Luminous Flux (lm)	
	Min.	Max.
3A	42	50
4A	50	55
5A	55	60

^[1] Tolerance $\pm 10\%$

Forward Voltage Bin Groups

$I_F = 150\text{mA}$, $T_A = +25^\circ\text{C}$, unless otherwise stated

Group	Forward Voltage V_F ^[1] (V)	
	Min.	Max.
V1	2.8	2.9
V2	2.9	3.0
V3	3.0	3.1
V4	3.1	3.2
V5	3.2	3.3
V6	3.3	3.4

^[1] Tolerance $\pm 0.1\text{V}$.

Chromaticity Binning

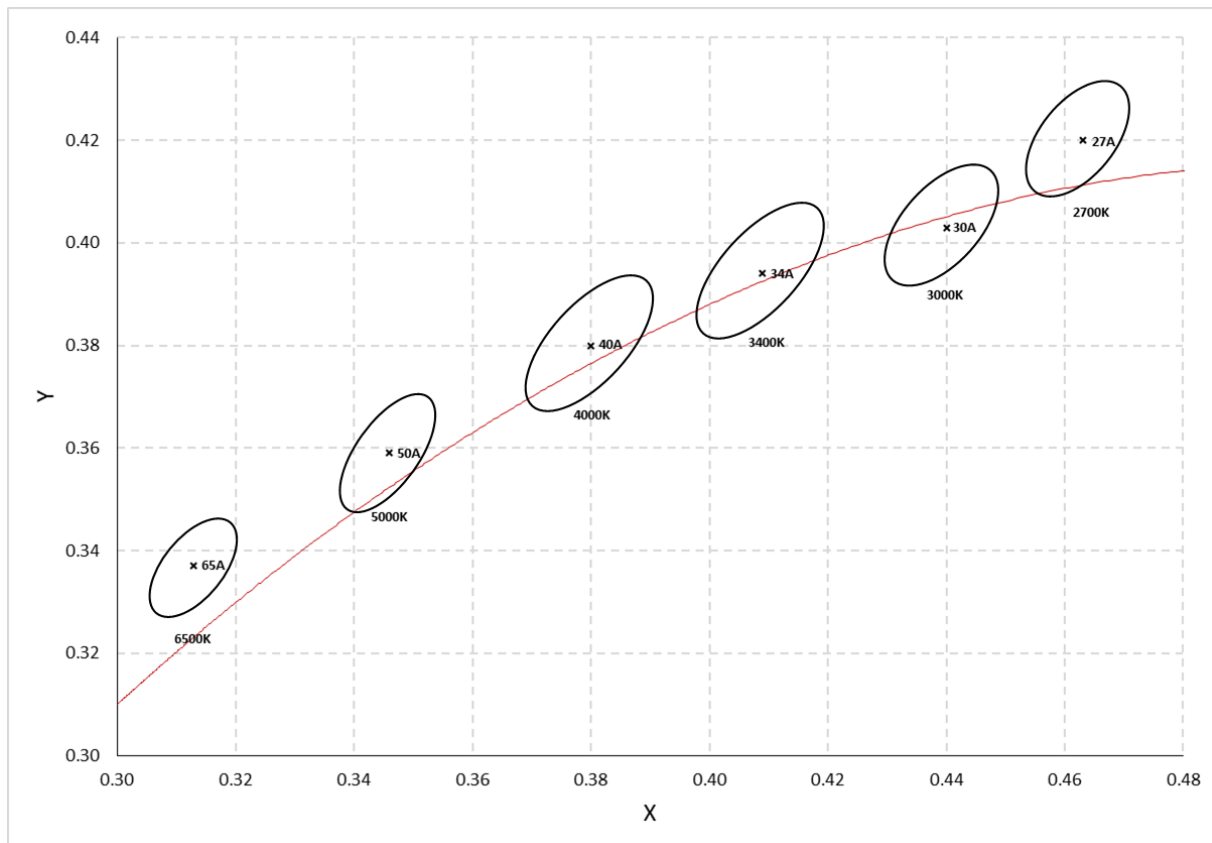

Figure 1: Colour Chromaticity Binning
 Chromaticity tolerance: ± 0.003

CCT (K)	Bin	CIE x	CIE y	a	d	θ
6500	65A	0.313	0.337	0.01115	0.00475	58°23'
5000	50A	0.346	0.359	0.0137	0.00590	59°37'
4000	40A	0.380	0.380	0.01565	0.00670	54°00'
3400	34A	0.409	0.394	0.01585	0.00695	52°28'
3000	30A	0.440	0.403	0.01390	0.00680	53°10'
2700	27A	0.463	0.420	0.01290	0.00685	53°17'

Relative Spectral Emission

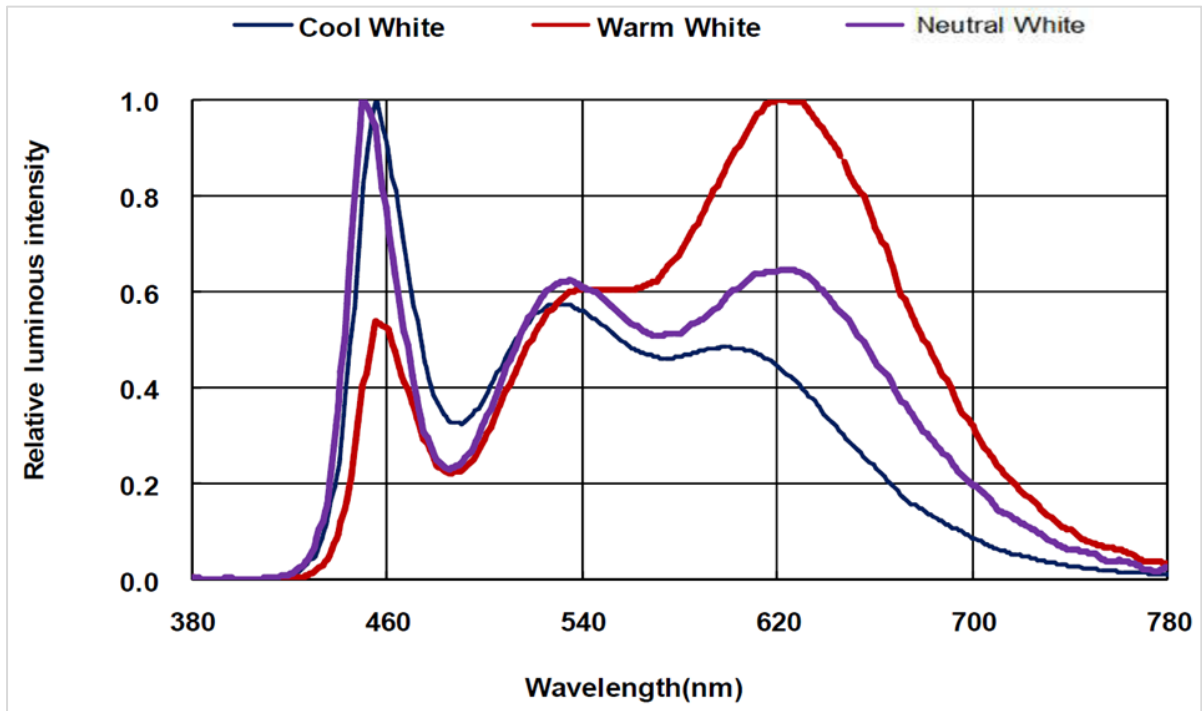

Figure 2: Normalised spectral power distribution

Forward Current Characteristics

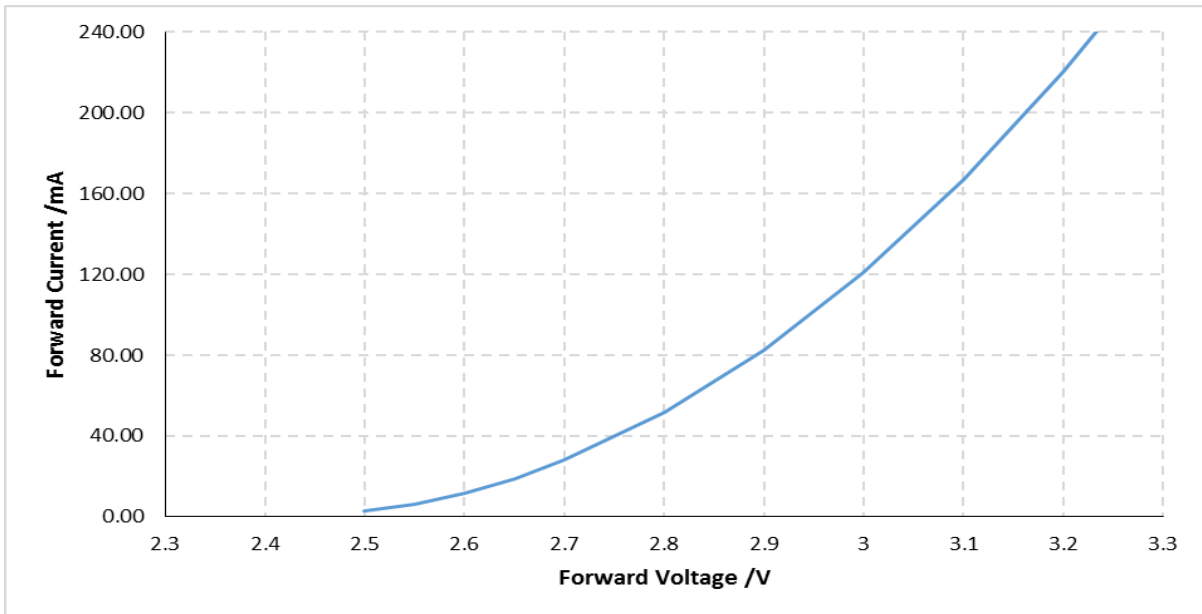

Figure 3: Typical forward current versus forward voltage ($T_a=+25^{\circ}\text{C}$)

Forward Current Characteristics (Continued)

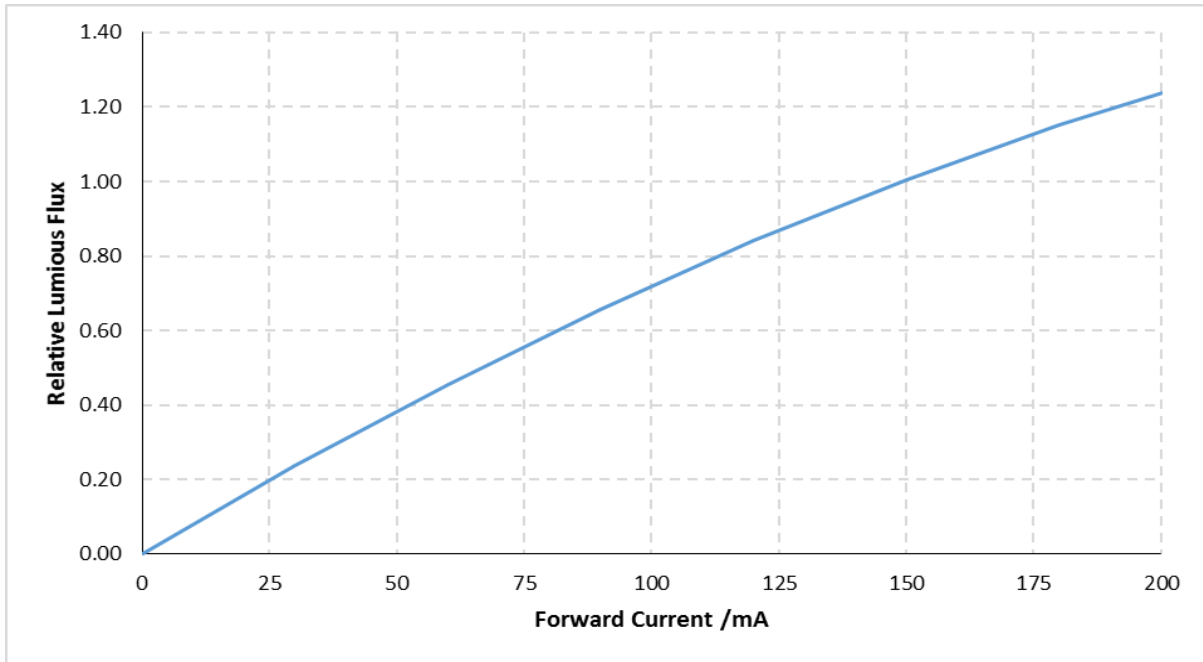

Figure 4: Relative luminous flux versus forward current ($T_a=+25^{\circ}\text{C}$) Temperature Characteristics

Temperature Characteristics

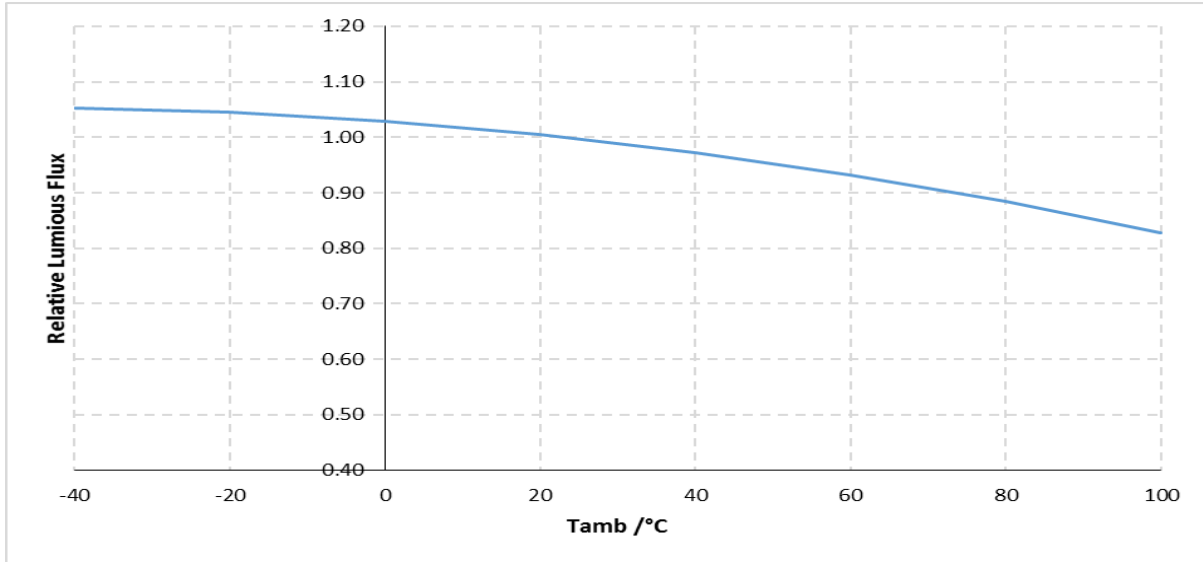
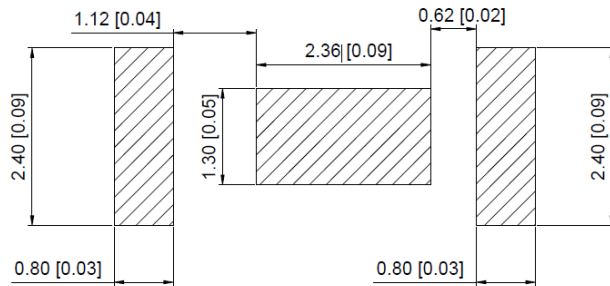

Figure 5: Relative Luminous Intensity versus ambient temperature ($I_F=150\text{mA}$)

Package Outline Dimensions & Soldering Pattern

Solder Pad Pattern Drawing



Mechanical Package Drawing

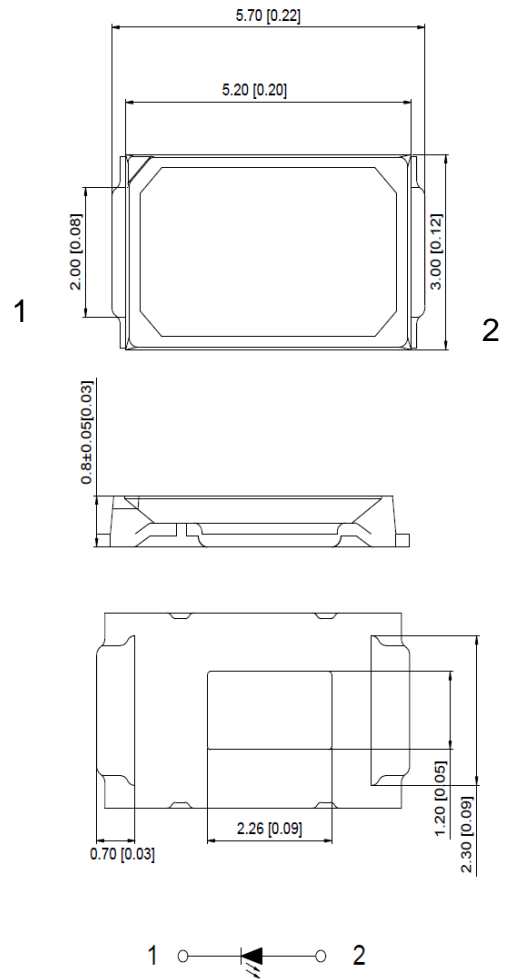

1. All dimensions units are millimeters.
2. All dimensions tolerances are ± 0.15 mm unless otherwise stated.

Figure 6: Mechanical Drawing & Soldering Pattern of the 5630 package

Reflow Soldering Profile

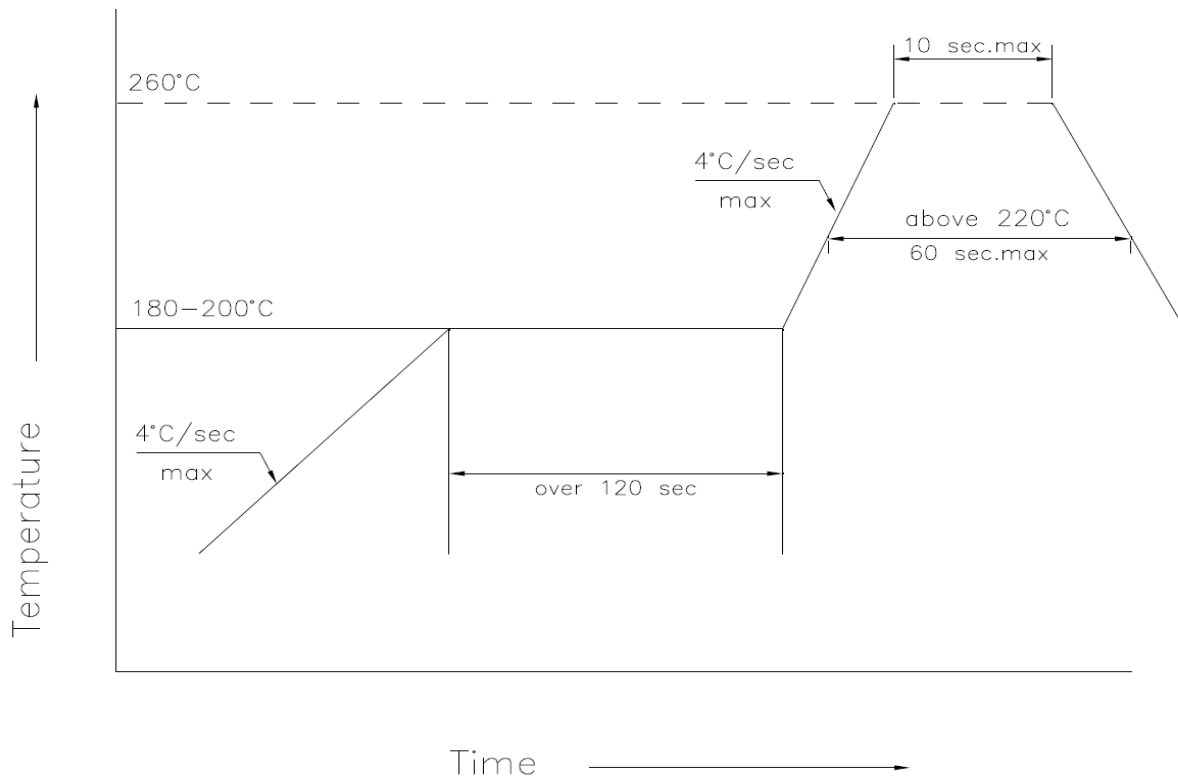

Figure 7: Reflow soldering profile

1. Reflow soldering should not be done more than twice
2. When soldering, do not put stress on the LEDs during heating

Soldering iron

1. When hand soldering, the temperature of the iron must be $\leq +300^{\circ}\text{C}$ for 3 seconds
2. Hand soldering should be performed only once.

Handling Instructions

Plessey LEDs are not designed to operate with reverse bias.

Precautions are required to prevent reverse bias in applications and during handling.

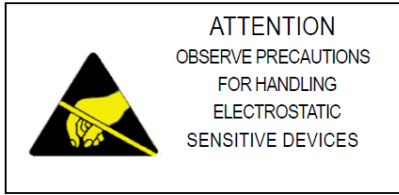

Moisture Sensitivity

JEDEC Level	Floor life		Soak Requirements	
	Time	Conditions	Time	Conditions
4	72 hours	≤+30°C / 60% RH	96±2 hours	+30°C / 60% RH

Packing Information

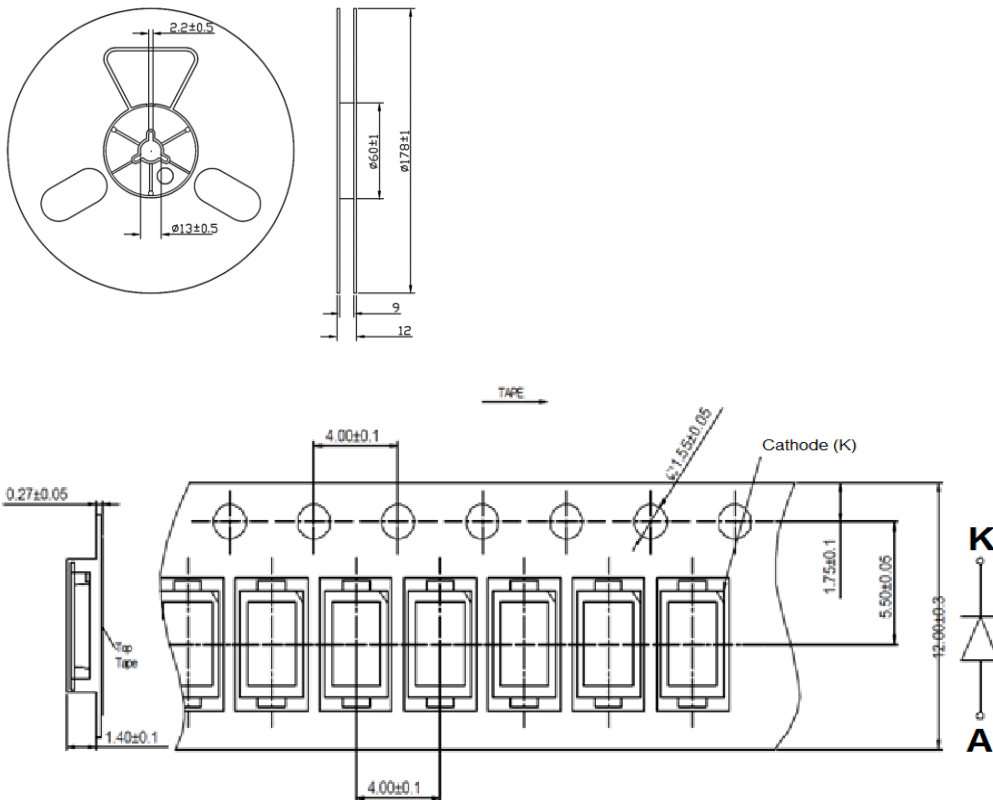

Figure 8: Reel Specification (units in mm)

Legal Notice

Product information provided by Plessey Semiconductors Limited (“Plessey”) in this document is believed to be correct and accurate. Plessey reserves the right to change/correct the specifications and other data or information relating to products without notice but Plessey accepts no liability for errors that may appear in this document, howsoever occurring, or liability arising from the use or application of any information or data provided herein. Neither the supply of such information, nor the purchase or use of products conveys any licence or permission under patent, copyright, trademark or other intellectual property right of Plessey or third parties.

Products sold by Plessey are subject to its standard Terms and Conditions of Sale that are available on request. No warranty is given that products do not infringe the intellectual property rights of third parties, and furthermore, the use of products in certain ways or in combination with Plessey, or non-Plessey furnished equipments/components may infringe intellectual property rights of Plessey.

The purpose of this document is to provide information only and it may not be used, applied or reproduced (in whole or in part) for any purpose nor be taken as a representation relating to the products in question. No warranty or guarantee express or implied is made concerning the capability, performance or suitability of any product, and information concerning possible applications or methods of use is provided for guidance only and not as a recommendation. The user is solely responsible for determining the performance and suitability of the product in any application and checking that any specification or data it seeks to rely on has not been superseded.

Products are intended for normal commercial applications. For applications requiring unusual environmental requirements, extended temperature range, or high reliability capability (e.g. military or medical applications), special processing/testing/conditions of sale may be available on application to Plessey.

Contact

Customer Enquiries/Sales

+44 1752 693000 | sales@plesseysemi.com | www.plesseysemi.com

Plessey Semiconductors Ltd | Plymouth

Tamerton Road, Roborough

Plymouth, Devon

PL6 7BQ United Kingdom

Компания «Life Electronics» занимается поставками электронных компонентов импортного и отечественного производства от производителей и со складов крупных дистрибьюторов Европы, Америки и Азии.

С конца 2013 года компания активно расширяет линейку поставок компонентов по направлению коаксиальный кабель, кварцевые генераторы и конденсаторы (керамические, пленочные, электролитические), за счёт заключения дистрибьюторских договоров

Мы предлагаем:

- Конкурентоспособные цены и скидки постоянным клиентам.
- Специальные условия для постоянных клиентов.
- Подбор аналогов.
- Поставку компонентов в любых объемах, удовлетворяющих вашим потребностям.
- Приемлемые сроки поставки, возможна ускоренная поставка.
- Доставку товара в любую точку России и стран СНГ.
- Комплексную поставку.
- Работу по проектам и поставку образцов.
- Формирование склада под заказчика.
- Сертификаты соответствия на поставляемую продукцию (по желанию клиента).
- Тестирование поставляемой продукции.
- Поставку компонентов, требующих военную и космическую приемку.
- Входной контроль качества.
- Наличие сертификата ISO.

В составе нашей компании организован Конструкторский отдел, призванный помогать разработчикам, и инженерам.

Конструкторский отдел помогает осуществить:

- Регистрацию проекта у производителя компонентов.
- Техническую поддержку проекта.
- Защиту от снятия компонента с производства.
- Оценку стоимости проекта по компонентам.
- Изготовление тестовой платы монтаж и пусконаладочные работы.



Тел: +7 (812) 336 43 04 (многоканальный)

Email: org@lifeelectronics.ru