

1-Cell Li-Ion or Polymer Battery Secondary Protection IC

NO.EA-380-181015

OUTLINE

The R5458L is a high voltage tolerant CMOS-based overcharge secondary protection IC for 1-Cell Li-ion or Li-polymer battery. The R5458L monitors the cell batteries and protects them from overcharge conditions. Internally, the R5458L consists of a voltage detector, a voltage reference unit, an oscillator, a counter, a delay circuit, and a logic circuit.

The cell is monitored for overcharging condition and triggers an internal counter once the overcharge threshold is exceeded. After the overcharge detection delay time, the output of COUT is transitioned to a high level. The output of COUT goes low if the cell voltage drops below the overcharge release voltage. The output type of the COUT pin is CMOS. The R5458L is offered in a small 6-pin DFN1814-6C package.

FEATURES

- **High Voltage Tolerant Process**

Absolute Maximum Ratings30 V

- **Low Supply Current**

Operating at 3.9 V Cell Voltage.....Typ. 1.5 μ A

Standby Current.....Max. 0.5 μ A

- **Output Voltage**

COUT Pin Output.....VDD Power Supply CMOS Output, Active-high

- **High Accuracy Voltage Detection**

Overcharge Detector Threshold (V_{DET1}).....4.0 V to 4.7 V in 0.005 V step

Overcharge Release Voltage (V_{REL1}) $V_{DET1}-0$ V to $V_{DET1}-0.4$ V in 0.05 V step

Overcharge Detector Threshold Accuracy ± 20 mV, $T_a = 25^\circ\text{C}$

± 25 mV, $T_a = 0$ to 60°C

Overcharge Release TypeVoltage Release Type

- **Overcharge Output Delay Function**

Overcharge Detection Delay Time2 s

Overcharge Release Delay Time16 ms

Overcharge Detection Delay Time ShorteningOvercharge detection delay time can be shortened by short-circuiting the VSS pin and the DS pin.

- **Compact Package**

DFN1814-6C 1.4 mm x 1.8 mm

APPLICATIONS

- 1-Cell Li-Ion or Li-Polymer Battery Pack

R5458L

NO.EA-380-181015

SELECTION GUIDE

The overcharge detector threshold and overcharge release voltage, the overcharge detection delay time and overcharge release delay time, and the overcharge release type are user-selectable options.

Selection Guide

Product Name	Package	Quantity per Reel	Pb Free	Halogen Free
R5458Lxxx*\$\$-TR	DFN1814-6C	5,000 pcs	Yes	Yes

xxx: Specify the combination of overcharge detector threshold (V_{DET1}) and overcharge release voltage (V_{REL1}). Refer to *Product Code Table* for details.

V_{DET1} : 4.0 V to 4.7 V in 5 mV step

V_{REL1} : $V_{DET1} - 0$ V to 0.4 V in 50 mV step

*: Specify the combination of overcharge detection delay time (t_{VDET1}) and overcharge release delay time (t_{VREL1}). Refer to the table below.

Delay Time Code

Code	t_{VDET1} [s]	t_{VREL1} [ms]
A	2	16

\$\$: Specify the overcharge release type. Refer to the table below.

Overcharge Release Code

Code	Overcharge Release Type
A	Voltage Release Type

Product Code Table

The product code is determined by the combination of set output voltage (overcharge detector threshold: V_{DET1} , overcharge release voltage: V_{REL1}) and delay time (overcharge detection delay time: t_{VDET1} , overcharge release delay time: t_{VREL1}) and overcharge release type.

Product Code Table

Product Name	Set Output Voltage [V]		Delay Time		Overcharge Release Type
	V_{DET1}	V_{REL1}	t_{VDET1} [s]	t_{VREL1} [ms]	
R5458L101AA	4.500	4.150	2	16	Voltage Release Type
R5458L102AA	4.550	4.200	2	16	Voltage Release Type
R5458L103AA	4.650	4.300	2	16	Voltage Release Type
R5458L104AA	4.600	4.300	2	16	Voltage Release Type

BLOCK DIAGRAMS

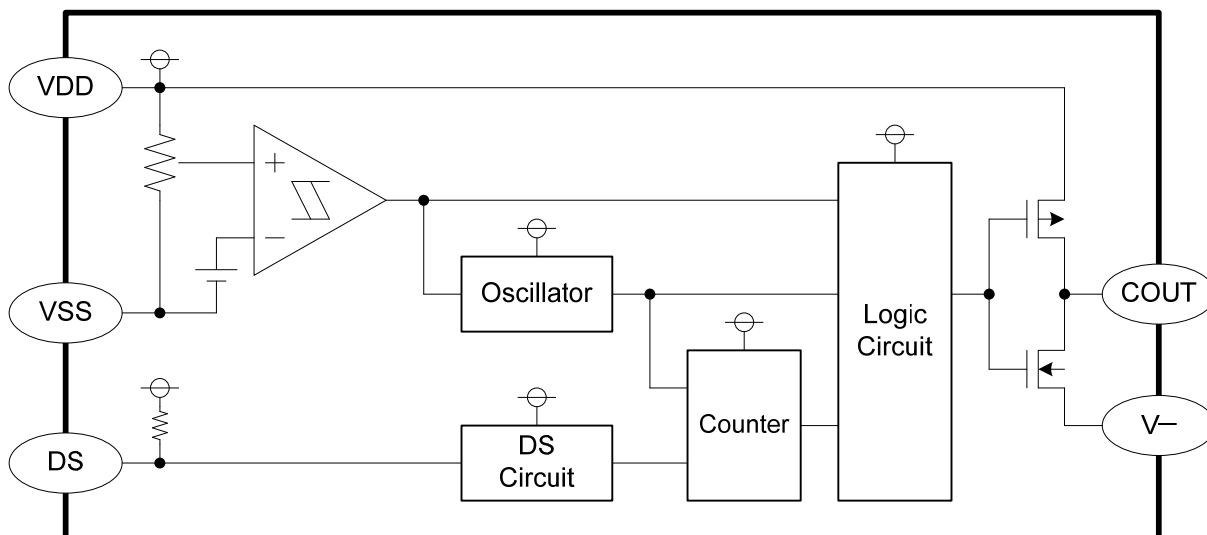

R5458L Block Diagram

R5458L

NO.EA-380-181015

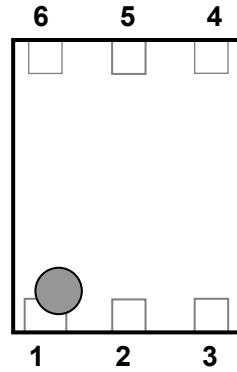
PIN DESCRIPTIONS**DFN1814-6C Pin Configuration****DFN1814-6C Pin Description**

Pin No.	Symbol	Description
1	NC	No Connection
2	COUT	Output of Overcharge Detection
3	DS	Delay Shortening
4	VSS	Ground
5	VDD	Power Supply, substrate level of the IC
6	V-	Negative Power Supply of COUT Pin

ABSOLUTE MAXIMUM RATINGS

Absolute Maximum Ratings

(Ta = 25°C, V_{SS} = 0 V)

Symbol	Item	Ratings	Unit
V _{DD}	Power Supply Voltage	-0.3 to 12	V
V ₋	V ₋ Pin Input Voltage	V _{DD} -30 to V _{DD} +0.3	V
DS	DS Pin Input Voltage	V _{SS} -0.3 to V _{DD} +0.3	V
V _{COU}	COU Pin Output Voltage	V ₋ -0.3 to V _{DD} +0.3	V
P _D	Power Dissipation	150	mW
T _j	Junction Temperature Range	-40 to 125	°C
T _{stg}	Storage Temperature Range	-55 to 125	°C

ABSOLUTE MAXIMUM RATINGS

Electronic and mechanical stress momentarily exceeded absolute maximum ratings may cause the permanent damages and may degrade the life time and safety for both device and system using the device in the field. The functional operation at or over these absolute maximum ratings is not assured.

RECOMMENDED OPERATING CONDITIONS

Recommended Operating Conditions

Symbol	Item	Ratings	Unit
V _{DD}	Operating Input Voltage	1.5 to 5.0	V
T _a	Operating Temperature Range	-40 to 85	°C

RECOMMENDED OPERATING CONDITIONS

All of electronic equipment should be designed that the mounted semiconductor devices operate within the recommended operating conditions. The semiconductor devices cannot operate normally over the recommended operating conditions, even if when they are used over such conditions by momentary electronic noise or surge. And the semiconductor devices may receive serious damage when they continue to operate over the recommended operating conditions.

R5458L

NO.EA-380-181015

ELECTRICAL CHARACTERISTICS

Ta = 25°C, unless otherwise specified.

R5458L Electrical Characteristics

(Ta = 25°C)

Symbol	Item	Conditions	Min.	Typ.	Max.	Unit	Test Circuit
V _{DET1}	Overcharge Detector Threshold	Detect rising edge of supply voltage (25°C) R1 = 330 Ω	V _{DET1} -0.020	V _{DET1}	V _{DET1} +0.020	V	A
		Detect rising edge of supply voltage (0 to 60°C) ¹ R1 = 330 Ω	V _{DET1} -0.025		V _{DET1} +0.025		
V _{REL1}	Overcharge Release Voltage	Detect falling edge of supply voltage R1 = 330 Ω	V _{REL1} -0.050	V _{REL1}	V _{REL1} +0.050	V	A
t _{VDET1}	Output Delay of Overcharge	V _{DD} = 3.5 V to 4.8 V	t _{VDET1} ×0.8	t _{VDET1}	t _{VDET1} ×1.2	s	A
t _{VREL1}	Output Delay of Release from Overcharge	V _{DD} = 4.8 V to 3.5 V	t _{VREL1} ×0.8	t _{VREL1}	t _{VREL1} ×1.2	ms	A
V _{DS}	Delay Time Shortening Mode Voltage	V _{DD} = 4.8 V			0.4	V	B
R _{DS}	DS Pin Pull-up Resistances	V _{DD} = 3.9 V	200	500	1000	kΩ	C
V _{OH}	COUT Pch On Voltage	I _{OH} = -50 μA, V _{DD} = 4.8 V	4.3	4.6		V	D
V _{OL}	COUT Nch On Voltage	I _{OL} = 50 μA, V _{DD} = 3.9 V		0.4	0.5	V	E
I _{standby}	Standby Current	V _{DD} = 1.9 V		0	0.5	μA	F
I _{SS}	Supply Current	V _{DD} = 3.9 V		1.5	3.0	μA	F

¹ This specification is guaranteed by design, not tested in mass-production.

TEST CIRCUITS

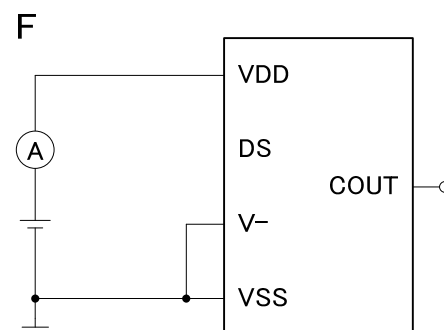
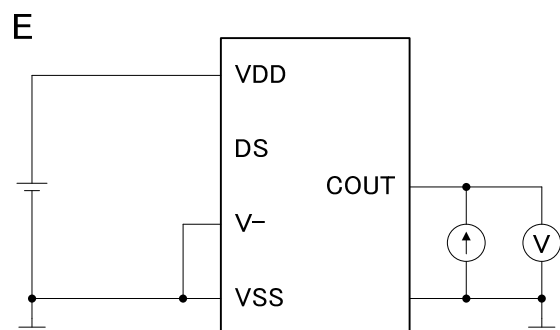
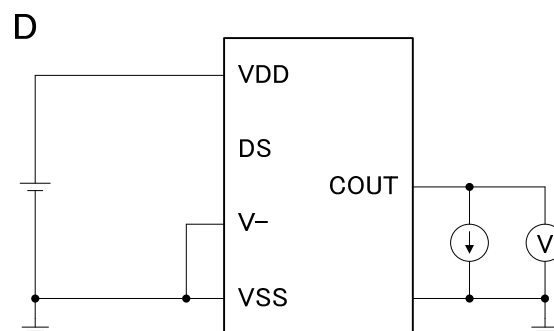
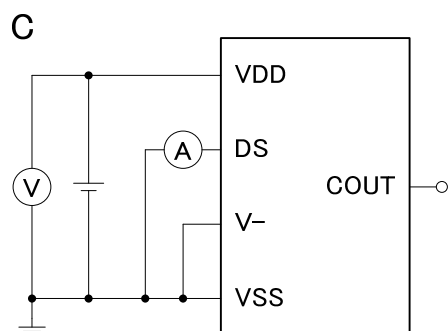
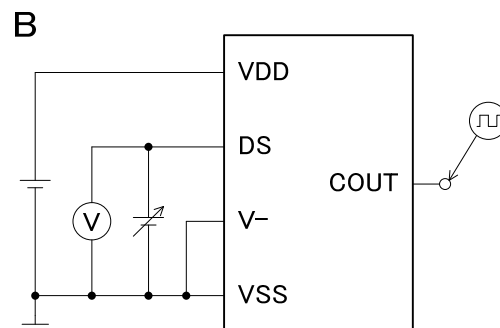
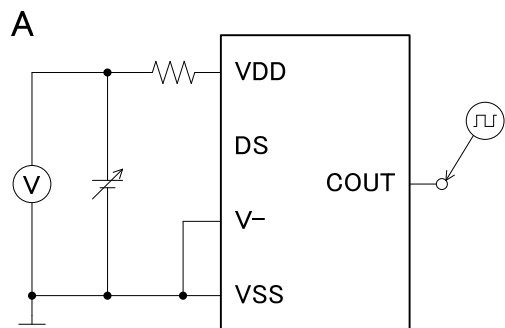

THEORY OF OPERATION

V_{DET1} / Overcharge Detector

The voltage between the VDD pin and the VSS pin is monitored while the cell is charged. The cell is monitored for overcharging condition and triggers an internal counter once the cell voltage exceeds the overcharge detector threshold. After the overcharge detection delay time, an external charging control Nch MOSFET turns on, which means the output of COUT is transitioned to a high level, a fuse on the charger path is cut, and the charging stops. The output of COUT goes low if the cell voltage drops below the overcharge release voltage. During the overcharge detection/ release delay time, the cell voltage needs to be kept more than the overcharge detector threshold/ release voltage level to make the output of COUT high/ low. The output type of the COUT pin is CMOS output between V- and VDD.

Delay Shortening Function

The overcharge detection delay time can be shortened to approx. 4 ms by short-circuiting the VSS pin and the DS pin (Max. 0.4 V).

Timing Chart

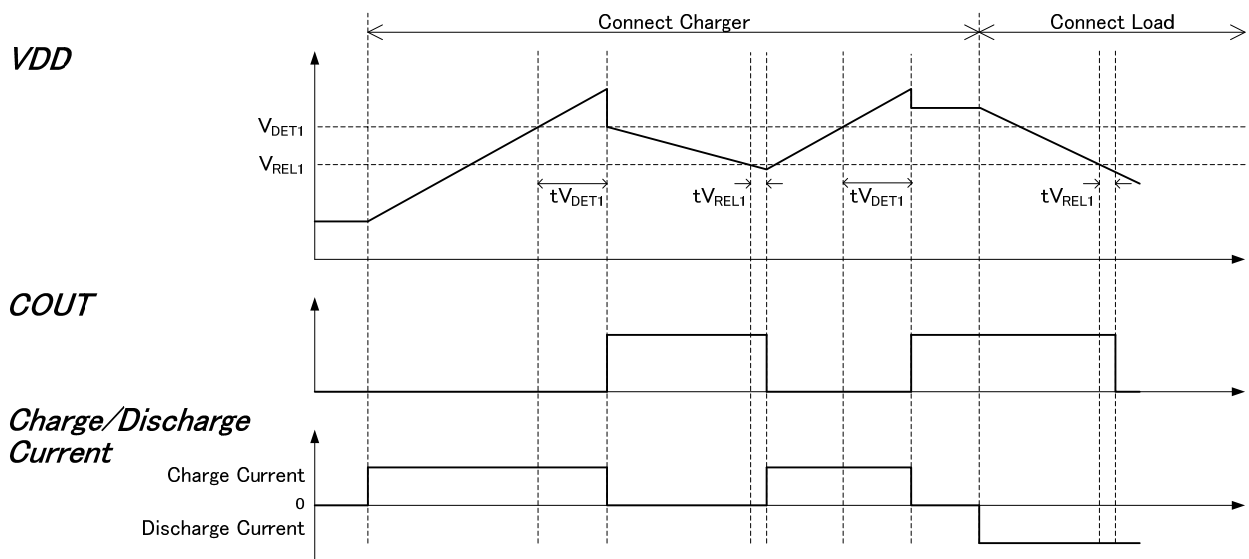

Overcharge Operation Timing Chart

APPLICATION INFORMATION

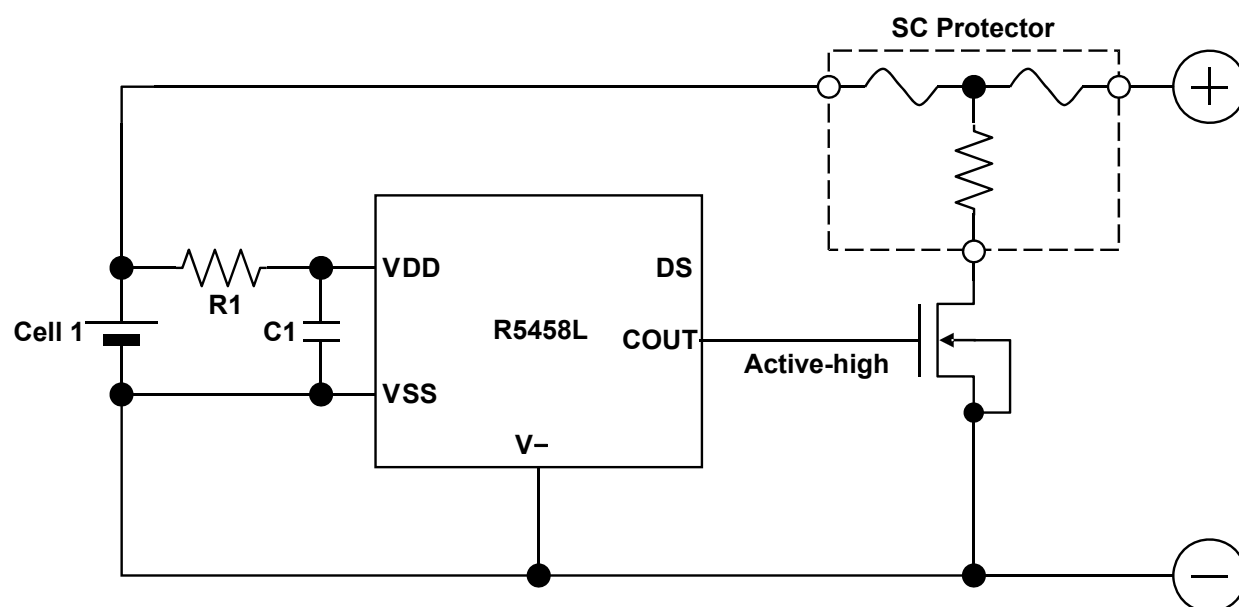

R5458L Typical Application Circuit

Recommended External Components

Symbol	Typ.	Unit	Range
R1	330	Ω	330 to 1000
C1	0.1	μF	0.01 to 0.1

R5458L

NO.EA-380-181015

Technical Notes on the Selection of Components

- R1 and C1 stabilize a supply voltage to the IC. A recommended R1 value is equal or less than 1 k Ω . A large value of R1 makes detection voltage shift higher because of the conduction current flowed in the IC.
- To stabilize the operation of the IC, use the C1 with the value in the range from 0.01 μ F to 0.1 μ F. To choose the most suitable value of C1, fully evaluation is necessary.
- The typical application circuit diagrams are just examples. This circuit performance largely depends on the PCB layout and external components. In the actual application, fully evaluation is necessary.
- Overvoltage and the overcurrent beyond the absolute maximum rating should not be forced to the protection IC and external components. During the time until the fuse is open after detecting overcharge, a large current may flow through the FET. Select an FET with large enough current capacity in order to endure the large current.
- Ricoh cannot assume responsibility for use of any circuitry other than circuitry entirely embodied in a Ricoh product. If technical notes are not complied with the circuit which is used Ricoh product, Ricoh is not responsible for any damages and any accidents.
- To connect the SC protector, connect the SC protector to the cell must be the last.

Contact Information for Inquiries regarding SC Protector

Dexerials Corporation (Sony Chemical & Information Device Company Ltd.)

Gate-city Osaki East Tower 8F, 1-11-2 Osaki, Shinagawa, Tokyo, 141-0032

TEL: 03-5435-3946

URL: <http://www.dexerials.jp>

TYPICAL CHARACTERISTICS (vs. Ambient Temperature)

Note: Typical Characteristics are intended to be used as reference data, they are not guaranteed.

1) Overcharge Detector Threshold

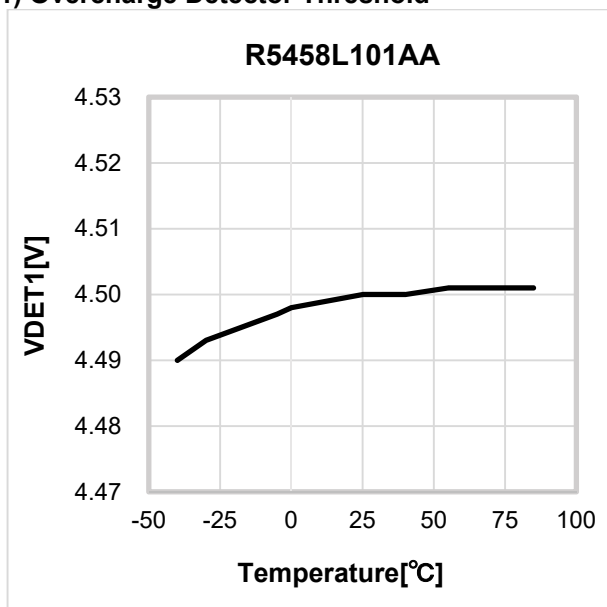

2) Overcharge Release Voltage

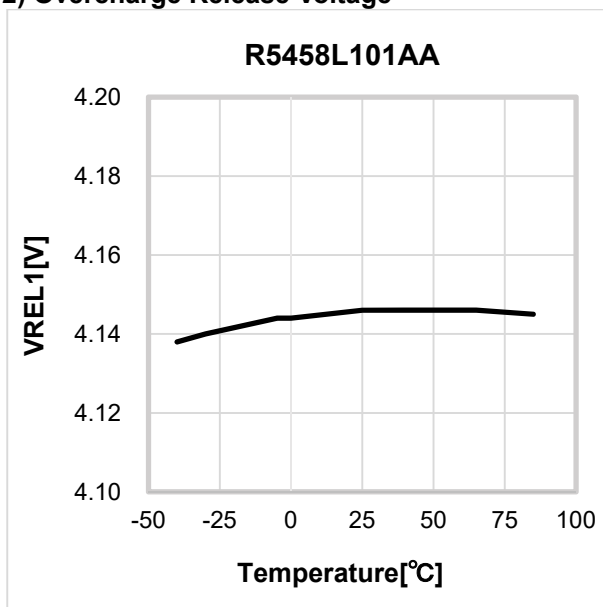

3) Overcharge Detection Output Delay Time

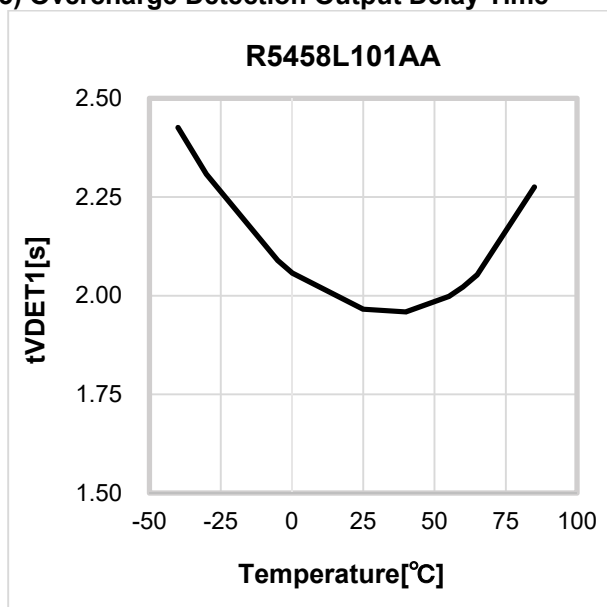

4) Overcharge Release Output Delay Time

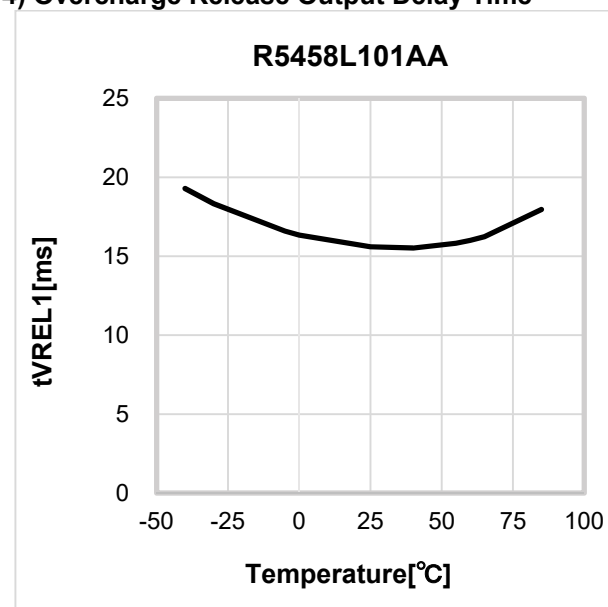

R5458L

NO.EA-380-181015

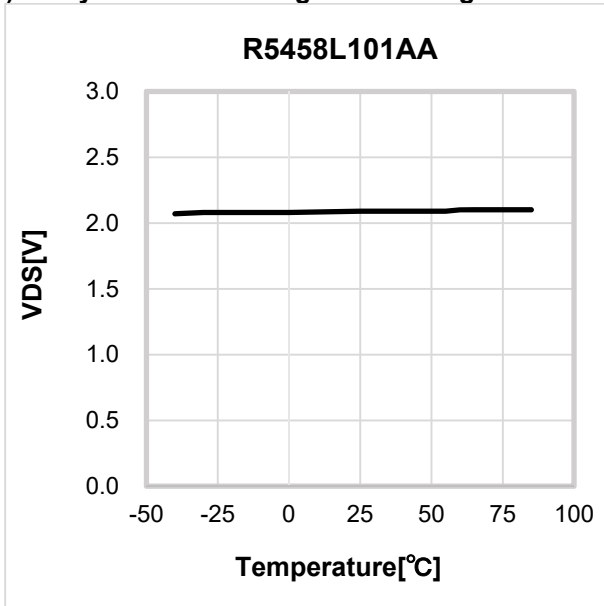
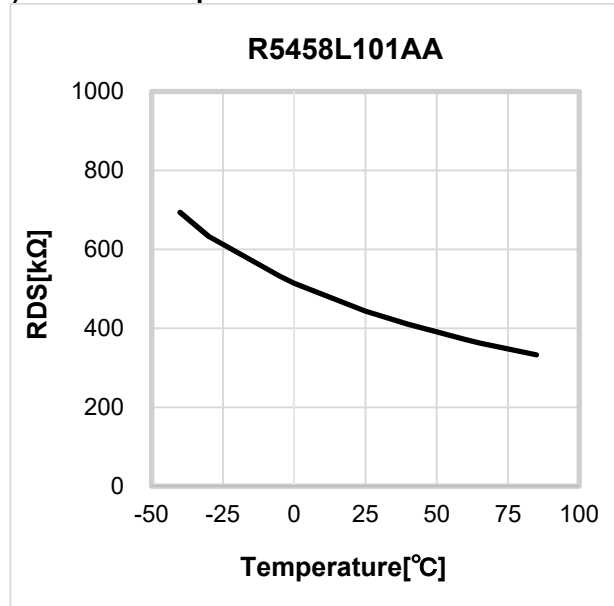
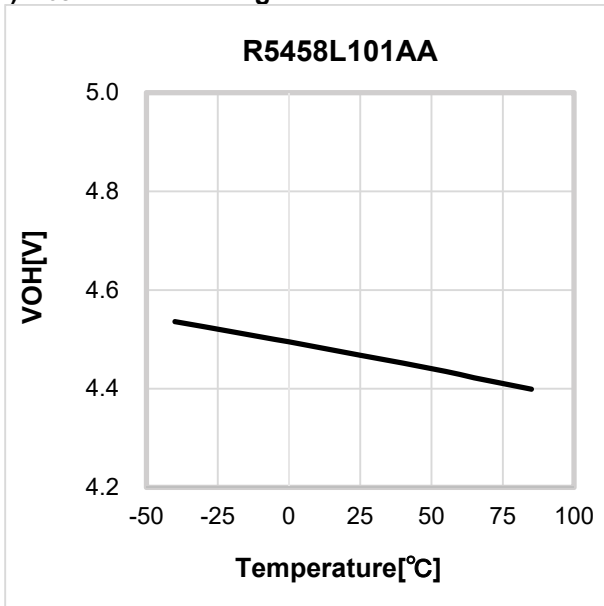
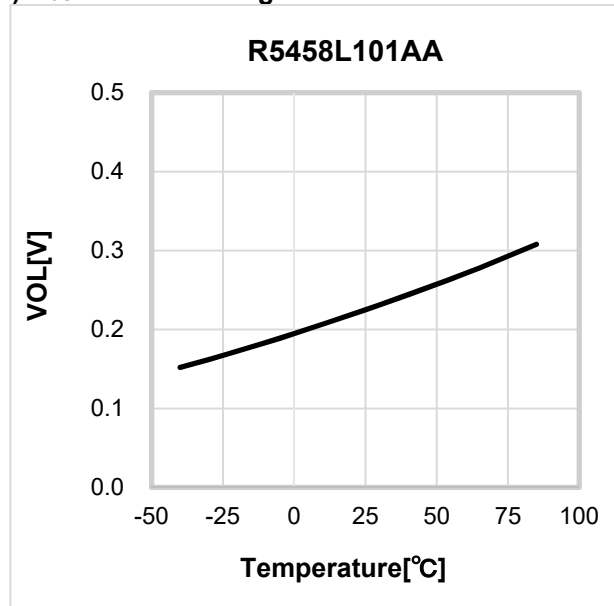
5) Delay Time Shortening Mode Voltage**6) DS Pin Pull-up Resistance****7) C_{OUT} Pch ON Voltage****8) C_{OUT} Nch ON Voltage**

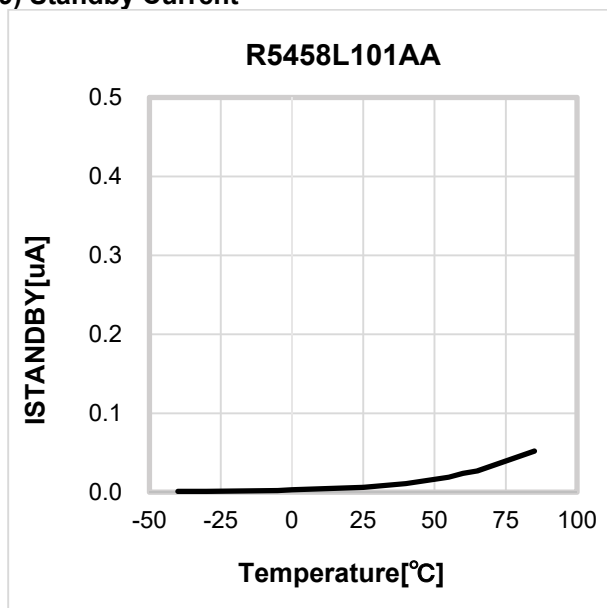
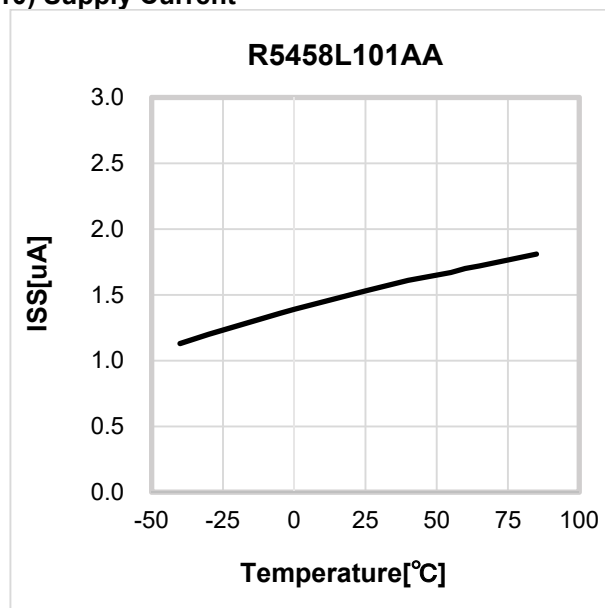
9) Standby Current**10) Supply Current**

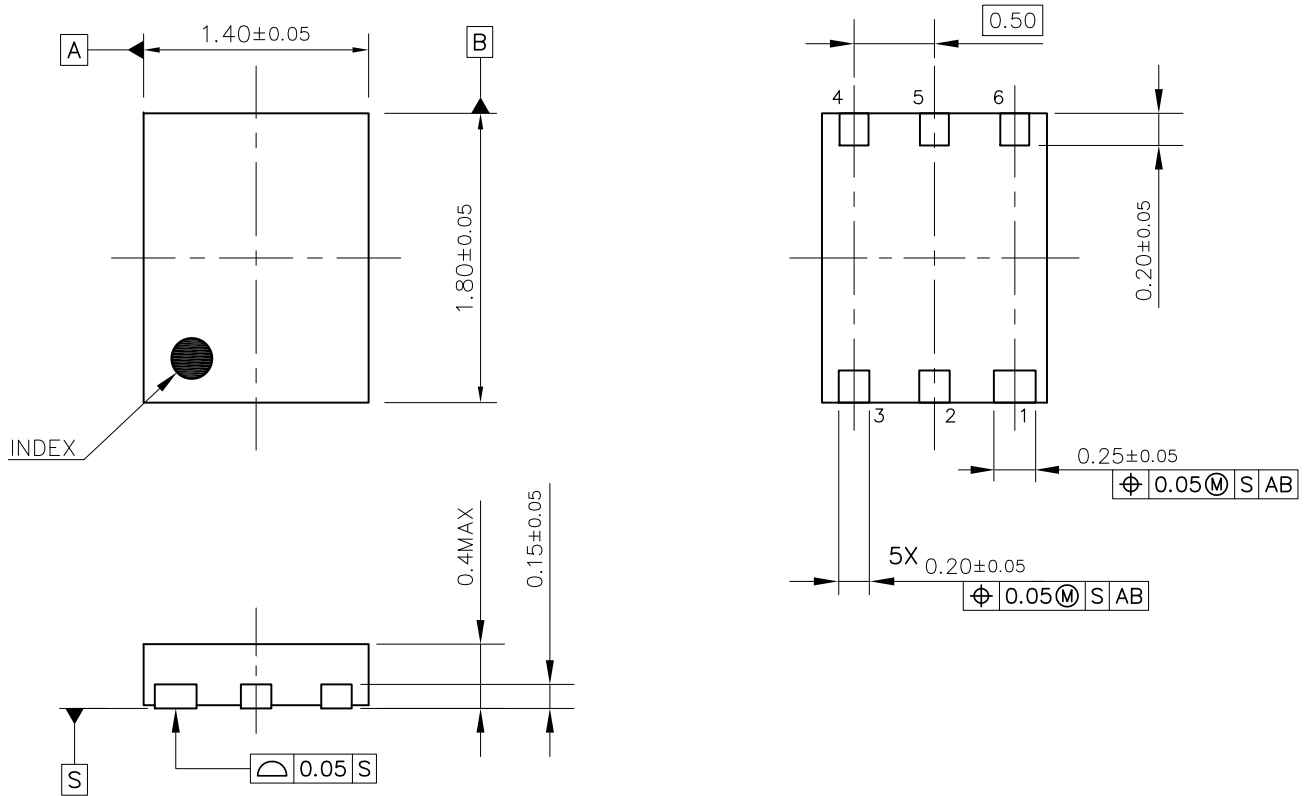

DFN1814-6C Package Dimensions (Unit: mm)



1. The products and the product specifications described in this document are subject to change or discontinuation of production without notice for reasons such as improvement. Therefore, before deciding to use the products, please refer to Ricoh sales representatives for the latest information thereon.
2. The materials in this document may not be copied or otherwise reproduced in whole or in part without prior written consent of Ricoh.
3. Please be sure to take any necessary formalities under relevant laws or regulations before exporting or otherwise taking out of your country the products or the technical information described herein.
4. The technical information described in this document shows typical characteristics of and example application circuits for the products. The release of such information is not to be construed as a warranty of or a grant of license under Ricoh's or any third party's intellectual property rights or any other rights.
5. The products listed in this document are intended and designed for use as general electronic components in standard applications (office equipment, telecommunication equipment, measuring instruments, consumer electronic products, amusement equipment etc.). Those customers intending to use a product in an application requiring extreme quality and reliability, for example, in a highly specific application where the failure or misoperation of the product could result in human injury or death (aircraft, spacevehicle, nuclear reactor control system, traffic control system, automotive and transportation equipment, combustion equipment, safety devices, life support system etc.) should first contact us.
6. We are making our continuous effort to improve the quality and reliability of our products, but semiconductor products are likely to fail with certain probability. In order to prevent any injury to persons or damages to property resulting from such failure, customers should be careful enough to incorporate safety measures in their design, such as redundancy feature, fire containment feature and fail-safe feature. We do not assume any liability or responsibility for any loss or damage arising from misuse or inappropriate use of the products.
7. Anti-radiation design is not implemented in the products described in this document.
8. The X-ray exposure can influence functions and characteristics of the products. Confirm the product functions and characteristics in the evaluation stage.
9. WLCSP products should be used in light shielded environments. The light exposure can influence functions and characteristics of the products under operation or storage.
10. There can be variation in the marking when different AOI (Automated Optical Inspection) equipment is used. In the case of recognizing the marking characteristic with AOI, please contact Ricoh sales or our distributor before attempting to use AOI.
11. Please contact Ricoh sales representatives should you have any questions or comments concerning the products or the technical information.



Ricoh is committed to reducing the environmental loading materials in electrical devices with a view to contributing to the protection of human health and the environment.

Ricoh has been providing RoHS compliant products since April 1, 2006 and Halogen-free products since April 1, 2012.

RICOH RICOH ELECTRONIC DEVICES CO., LTD.

<https://www.e-devices.ricoh.co.jp/en/>

Sales & Support Offices

Ricoh Electronic Devices Co., Ltd.

Shin-Yokohama Office (International Sales)

2-3, Shin-Yokohama 3-chome, Kohoku-ku, Yokohama-shi, Kanagawa, 222-8530, Japan
Phone: +81-50-3814-7687 Fax: +81-45-474-0074

Ricoh Americas Holdings, Inc.

675 Campbell Technology Parkway, Suite 200 Campbell, CA 95008, U.S.A.
Phone: +1-408-610-3105

Ricoh Europe (Netherlands) B.V.

Semiconductor Support Centre

Prof. W.H. Keesomlaan 1, 1183 DJ Amstelveen, The Netherlands
Phone: +31-20-5474-309

Ricoh International B.V. - German Branch

Semiconductor Sales and Support Centre

Oberrather Strasse 6, 40472 Düsseldorf, Germany
Phone: +49-211-6546-0

Ricoh Electronic Devices Korea Co., Ltd.

3F, Haesung Bldg, 504, Teheran-ro, Gangnam-gu, Seoul, 135-725, Korea
Phone: +82-2-2135-5700 Fax: +82-2-2051-5713

Ricoh Electronic Devices Shanghai Co., Ltd.

Room 403, No.2 Building, No.690 Bibo Road, Pu Dong New District, Shanghai 201203,
People's Republic of China
Phone: +86-21-5027-3200 Fax: +86-21-5027-3299

Ricoh Electronic Devices Shanghai Co., Ltd.

Shenzhen Branch

1205, Block D (Jinlong Building), Kingkey 100, Hongbao Road, Luohu District,
Shenzhen, China
Phone: +86-755-8348-7600 Ext 225

Ricoh Electronic Devices Co., Ltd.

Taipei office

Room 109, 10F-1, No.51, Hengyang Rd., Taipei City, Taiwan
Phone: +886-2-2313-1621/1622 Fax: +886-2-2313-1623

Mouser Electronics

Authorized Distributor

Click to View Pricing, Inventory, Delivery & Lifecycle Information:

[Ricoch Electronics:](#)

[R5458L102AA-TR](#) [R5458L104AA-TR](#)

Компания «Life Electronics» занимается поставками электронных компонентов импортного и отечественного производства от производителей и со складов крупных дистрибьюторов Европы, Америки и Азии.

С конца 2013 года компания активно расширяет линейку поставок компонентов по направлению коаксиальный кабель, кварцевые генераторы и конденсаторы (керамические, пленочные, электролитические), за счёт заключения дистрибьюторских договоров

Мы предлагаем:

- Конкуренеспособные цены и скидки постоянным клиентам.
- Специальные условия для постоянных клиентов.
- Подбор аналогов.
- Поставку компонентов в любых объемах, удовлетворяющих вашим потребностям.
- Приемлемые сроки поставки, возможна ускоренная поставка.
- Доставку товара в любую точку России и стран СНГ.
- Комплексную поставку.
- Работу по проектам и поставку образцов.
- Формирование склада под заказчика.
- Сертификаты соответствия на поставляемую продукцию (по желанию клиента).
- Тестирование поставляемой продукции.
- Поставку компонентов, требующих военную и космическую приемку.
- Входной контроль качества.
- Наличие сертификата ISO.

В составе нашей компании организован Конструкторский отдел, призванный помогать разработчикам, и инженерам.

Конструкторский отдел помогает осуществить:

- Регистрацию проекта у производителя компонентов.
- Техническую поддержку проекта.
- Защиту от снятия компонента с производства.
- Оценку стоимости проекта по компонентам.
- Изготовление тестовой платы монтаж и пусконаладочные работы.



Тел: +7 (812) 336 43 04 (многоканальный)

Email: org@lifeelectronics.ru