

# Type 2 surge protection connector - F-MS 12/ST - 2817990

Please be informed that the data shown in this PDF Document is generated from our Online Catalog. Please find the complete data in the user's documentation. Our General Terms of Use for Downloads are valid (<http://download.phoenixcontact.com>)



Surge protection plug type 2, with N-PE total current spark gap for base element.



## Key commercial data

Packing unit	1
Minimum order quantity	10
Catalog page	Page 36 (TT-2011)
GTIN	 4 017918 163648
Custom tariff number	85363010
Country of origin	GERMANY

## Technical data

### Standards

Housing material	PA
Inflammability class according to UL 94	V0
Color	black
Standards for air and creepage distances	EN 60664-1
Standards for air and creepage distances	EN 61643-11
Surge voltage category	III
Pollution degree	2
Degree of protection	IP20
Mounting type	On base element
Design	DIN rail module, two-section, divisible
Number of positions	1
Ambient temperature (operation)	-40 °C ... 80 °C
Arrester can be tested with CHECKMASTER from software version:	From SW rev. 1.10
Message: Surge protection fault	Optical
Direction of action	N-PE
Width	17.7 mm

# Type 2 surge protection connector - F-MS 12/ST - 2817990

## Technical data

### Standards

Height	52.5 mm
Depth	55.5 mm
Pitch unit	1 Div.

### Protective circuit

IEC category	II
IEC category	T2
EN type	T2
Nominal voltage UN	230 V AC
Nominal DC sparkover voltage Uagn	500 V ±20 %
Arrester rated voltage UC	260 V AC
Arrester rated voltage UC (N-PE)	260 V AC
UT (TOV-proof)	1200 V AC (200 ms / N-PE)
Nominal frequency fN	50 Hz
Nominal frequency fN	60 Hz
Ground conductor current IPE	≤ 1 µA
Standby power consumption PC	0.3 mVA
Max. discharge surge current I <sub>max</sub> (8/20) µs	40 kA
Max. discharge surge current I <sub>max</sub> (8/20) µs maximum (N-PE)	40 kA
Nominal discharge surge current I <sub>n</sub> (8/20) µs	20 kA
Nominal discharge surge current I <sub>n</sub> (8/20) µs (N-PE)	20 kA
Lightning test current (10/350) µs, charge	6 As
Lightning test current (10/350) µs, peak value limp	12 kA
Impulse operate voltage at 6 kV (1.2/50)µs (N-PE)	≤ 1.5 kV
Insulation resistance Riso:	> 1 GΩ
Protection level Up	≤ 1.5 kV
Protection level UP (N-PE)	≤ 1.5 kV
Residual voltage	≤ 150 V (at 5 kA)
Residual voltage (N-PE)	≤ 150 V (at 5 kA)
Residual voltage (N-PE)	≤ 400 V
Residual voltage (N-PE)	≤ 250 V (at 10 kA)
Residual voltage (N-PE)	≤ 100 V (at 3 kA)
Response time	≤ 100 ns
Response time (N-PE)	≤ 100 ns
Follow current quenching capacity I <sub>f</sub> (N-PE)	100 A (260 V)

### Connection, protective circuit

Connection type IN	FLASHTRAB/VALVETRAB plug-in system
Connection type OUT	FLASHTRAB/VALVETRAB plug-in system

### Standards

Standards/regulations	IEC 61643-1 2005
Standards/regulations	EN 61643-11/A11 2007

# Type 2 surge protection connector - F-MS 12/ST - 2817990

## Classifications

### eclass

eCl@ss 4.0	27140201
eCl@ss 4.1	27130801
eCl@ss 5.0	27130801
eCl@ss 5.1	27130801
eCl@ss 6.0	27130805
eCl@ss 7.0	27130805

### etim

ETIM 2.0	EC000941
ETIM 3.0	EC000941
ETIM 4.0	EC000941
ETIM 5.0	EC000941

### unspsc

UNSPSC 6.01	30212010
UNSPSC 7.0901	39121610
UNSPSC 11	39121610
UNSPSC 12.01	39121610
UNSPSC 13.2	39121620

## Approvals

### Approvals

---

#### Approvals

ÖVE / IECEE CB Scheme / UL Recognized / KEMA-KEUR / cUL Recognized / GOST / GL / CCA / ÖVE / cULus Recognized

---

#### Ex Approvals

---

#### Approvals submitted

---

### Approval details

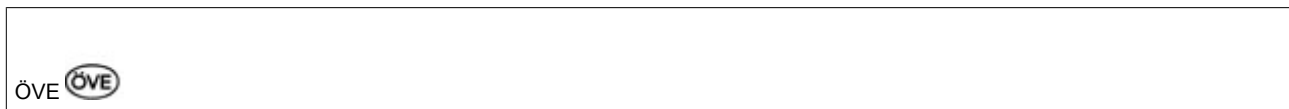

IECEE CB Scheme

# Type 2 surge protection connector - F-MS 12/ST - 2817990

## Approvals



## Accessories

Accessories

Marking

Zack marker strip - ZBN 18,LGS:ERDE - 2749589



Zack marker strip, Strip, white, Labeled, Horizontal: Grounding symbol, Mounting type: Snap into tall marker groove, For terminal block width: 18 mm, Lettering field: 18 x 5 mm

## Type 2 surge protection connector - F-MS 12/ST - 2817990

### Accessories

Zack marker strip - ZBN 18,LGS:L1-N,ERDE - 2749576



Zack marker strip, Strip, white, Labeled, Horizontal: L1, L2, L3, N, GND, Mounting type: Snap into tall marker groove, For terminal block width: 18 mm, Lettering field: 18 x 5 mm

Zack marker strip - ZBN 18:UNBEDRUCKT - 2809128



Zack marker strip, Strip, white, Unlabeled, Can be labeled with: Plotter, Mounting type: Snap into tall marker groove, For terminal block width: 18 mm, Lettering field: 18 x 5 mm

Marker pen - B-STIFT - 1051993



Marker pen, for manual labeling of unprinted Zack strips, smear-proof and waterproof, line thickness 0.5 mm

### Additional products

Type 2 surge protection device - F-MS 12/FM - 2817974



Surge arrester type 2, consisting of base element with remote indicator contact and protective plug with N-PE total current spark gap for mounting on NS 35/7.5, housing width: 17.5 mm (1 Div.)

Type 2 surge protection device - F-MS 12 - 2817987



Surge arrester type 2, consisting of base element and protective plug with N-PE total current spark gap for mounting on NS 35/7.5, housing width: 17.5 mm (1 Div.)

# Type 2 surge protection connector - F-MS 12/ST - 2817990

## Accessories

Type 2 surge protection base element - VAL-MS BE/FM - 2817738



Base element for type 2 arresters of the VALVETRAB MS series of products, with remote indication contact. Design: 1-channel

Type 2 surge protection base element - VAL-MS BE - 2817741



Base element for type 2 arresters of the VALVETRAB MS series of products. Design: 1-channel

## Drawings

Dimensioned drawing

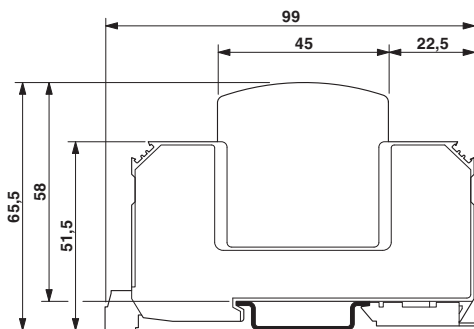

Circuit diagram



Компания «Life Electronics» занимается поставками электронных компонентов импортного и отечественного производства от производителей и со складов крупных дистрибьюторов Европы, Америки и Азии.

С конца 2013 года компания активно расширяет линейку поставок компонентов по направлению коаксиальный кабель, кварцевые генераторы и конденсаторы (керамические, пленочные, электролитические), за счёт заключения дистрибьюторских договоров

Мы предлагаем:

- Конкуренеспособные цены и скидки постоянным клиентам.
- Специальные условия для постоянных клиентов.
- Подбор аналогов.
- Поставку компонентов в любых объемах, удовлетворяющих вашим потребностям.
- Приемлемые сроки поставки, возможна ускоренная поставка.
- Доставку товара в любую точку России и стран СНГ.
- Комплексную поставку.
- Работу по проектам и поставку образцов.
- Формирование склада под заказчика.
- Сертификаты соответствия на поставляемую продукцию (по желанию клиента).
- Тестирование поставляемой продукции.
- Поставку компонентов, требующих военную и космическую приемку.
- Входной контроль качества.
- Наличие сертификата ISO.

В составе нашей компании организован Конструкторский отдел, призванный помогать разработчикам, и инженерам.

Конструкторский отдел помогает осуществить:

- Регистрацию проекта у производителя компонентов.
- Техническую поддержку проекта.
- Защиту от снятия компонента с производства.
- Оценку стоимости проекта по компонентам.
- Изготовление тестовой платы монтаж и пусконаладочные работы.



Тел: +7 (812) 336 43 04 (многоканальный)

Email: [org@lifeelectronics.ru](mailto:org@lifeelectronics.ru)