

MECHANICAL DATA

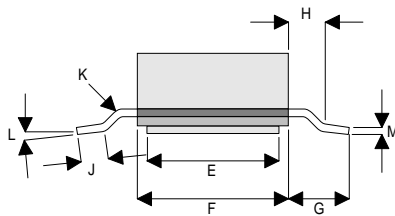
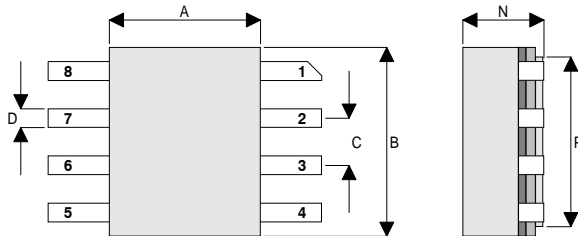

SO8 PACKAGE

- PIN 1 – SOURCE
- PIN 2 – DRAIN
- PIN 3 – DRAIN
- PIN 4 – SOURCE
- PIN 5 – SOURCE
- PIN 6 – GATE
- PIN 7 – GATE
- PIN 8 – SOURCE

Dim.	mm	Tol.	Inches	Tol.
A	4.06	±0.08	0.160	±0.003
B	5.08	±0.08	0.200	±0.003
C	1.27	±0.08	0.050	±0.003
D	0.51	±0.08	0.020	±0.003
E	3.56	±0.08	0.140	±0.003
F	4.06	±0.08	0.160	±0.003
G	1.65	±0.08	0.065	±0.003
H	0.76	+0.25 -0.00	0.030	+0.010 -0.000
J	0.51	Min.	0.020	Min.
	1.02	Max.	0.040	Max.
K	45°	Max.	45°	Max.
L	0°	Min.	0°	Min.
	7°	Max.	7°	Max.
M	0.20	±0.08	0.008	±0.003
N	2.18	Max.	0.086	Max.
P	4.57	±0.08	0.180	±0.003

**GOLD METALLISED
MULTI-PURPOSE SILICON
DMOS RF FET
10W – 50V – 500MHz
SINGLE ENDED**

FEATURES

- SIMPLIFIED AMPLIFIER DESIGN
- SUITABLE FOR BROAD BAND APPLICATIONS
- LOW C_{rss}
- USEFUL P_O AT 1GHz
- LOW NOISE
- HIGH GAIN – 13 dB MINIMUM

APPLICATIONS

- HF/VHF/UHF COMMUNICATIONS
from 1 MHz to 1 GHz

ABSOLUTE MAXIMUM RATINGS ($T_{case} = 25^{\circ}C$ unless otherwise stated)

P_D	Power Dissipation	30W
BV_{DSS}	Drain – Source Breakdown Voltage	125V
BV_{GSS}	Gate – Source Breakdown Voltage	±20V
$I_{D(sat)}$	Drain Current	3A
T_{stg}	Storage Temperature	-65 to 150°C
T_j	Maximum Operating Junction Temperature	200°C

Semelab Ltd reserves the right to change test conditions, parameter limits and package dimensions without notice. Information furnished by Semelab is believed to be both accurate and reliable at the time of going to press. However Semelab assumes no responsibility for any errors or omissions discovered in its use. Semelab encourages customers to verify that datasheets are current before placing orders.

ELECTRICAL CHARACTERISTICS (T_{case} = 25°C unless otherwise stated)

Parameter	Test Conditions	Min.	Typ.	Max.	Unit
B _V DSS Drain–Source Breakdown Voltage	V _{GS} = 0 I _D = 100mA	125			V
I _{DSS} Zero Gate Voltage Drain Current	V _{DS} = 50V V _{GS} = 0			1	mA
I _{GSS} Gate Leakage Current	V _{GS} = 20V V _{DS} = 0			1	μA
V _{GS(th)} Gate Threshold Voltage*	I _D = 10mA V _{DS} = V _{GS}	1		7	V
g _{fs} Forward Transconductance*	V _{DS} = 10V I _D = 0.5A	0.8			S
G _{PS} Common Source Power Gain	P _O = 10W	13			dB
η Drain Efficiency	V _{DS} = 50V I _{DQ} = 0.1A	50			%
VSWR Load Mismatch Tolerance	f = 500MHz	20:1			—
C _{iss} Input Capacitance	V _{DS} = 50V V _{GS} = -5V f = 1MHz			60	pF
C _{oss} Output Capacitance	V _{DS} = 50V V _{GS} = 0 f = 1MHz			25	pF
C _{rss} Reverse Transfer Capacitance	V _{DS} = 50V V _{GS} = 0 f = 1MHz			1.5	pF

* Pulse Test: Pulse Duration = 300 μs , Duty Cycle ≤ 2%

HAZARDOUS MATERIAL WARNING

The ceramic portion of the device between leads and metal flange is beryllium oxide. Beryllium oxide dust is highly toxic and care must be taken during handling and mounting to avoid damage to this area.

THESE DEVICES MUST NEVER BE THROWN AWAY WITH GENERAL INDUSTRIAL OR DOMESTIC WASTE.

THERMAL DATA

R _{THj-case}	Thermal Resistance Junction – Case	Max. 6°C / W
-----------------------	------------------------------------	--------------

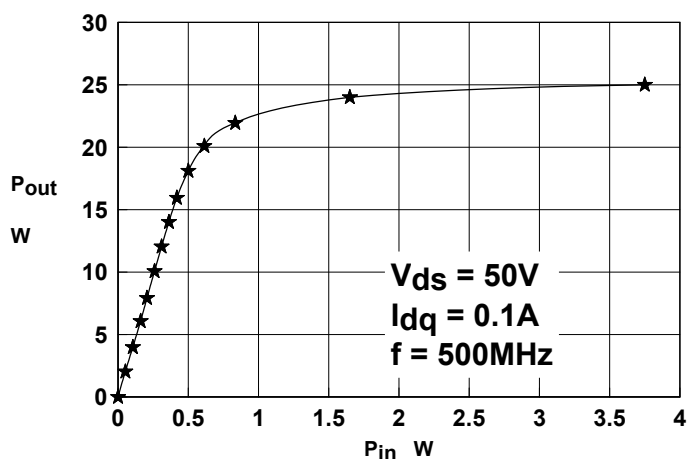

Figure 1. Output Power vs Input Power

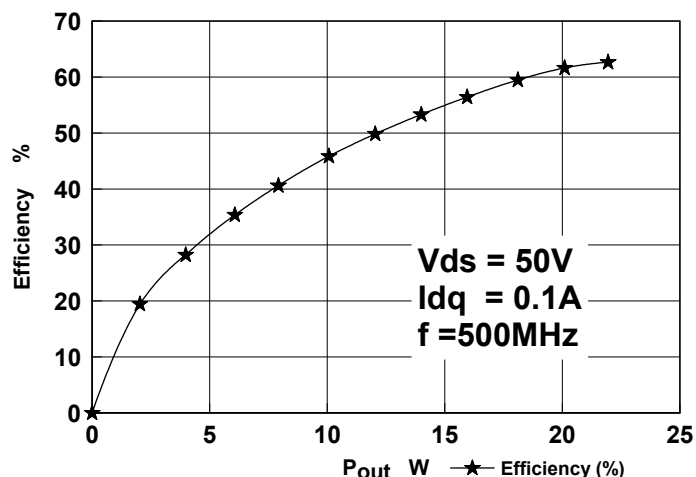

Figure 2. Efficiency vs. Output Power

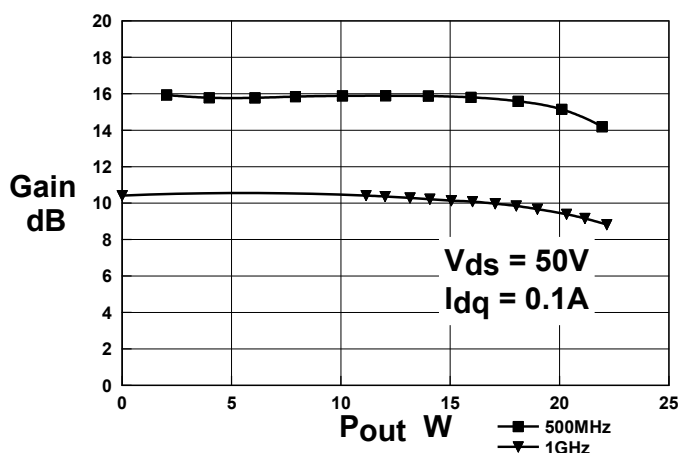

Figure 3. Gain vs Output Power

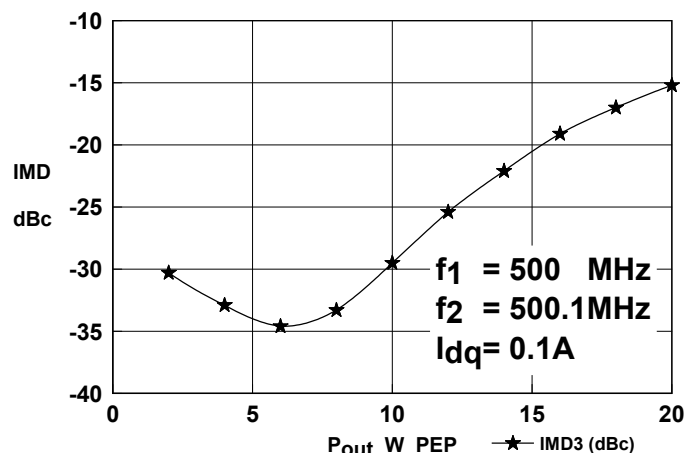

Figure 3. IMD 3 vs Output Power

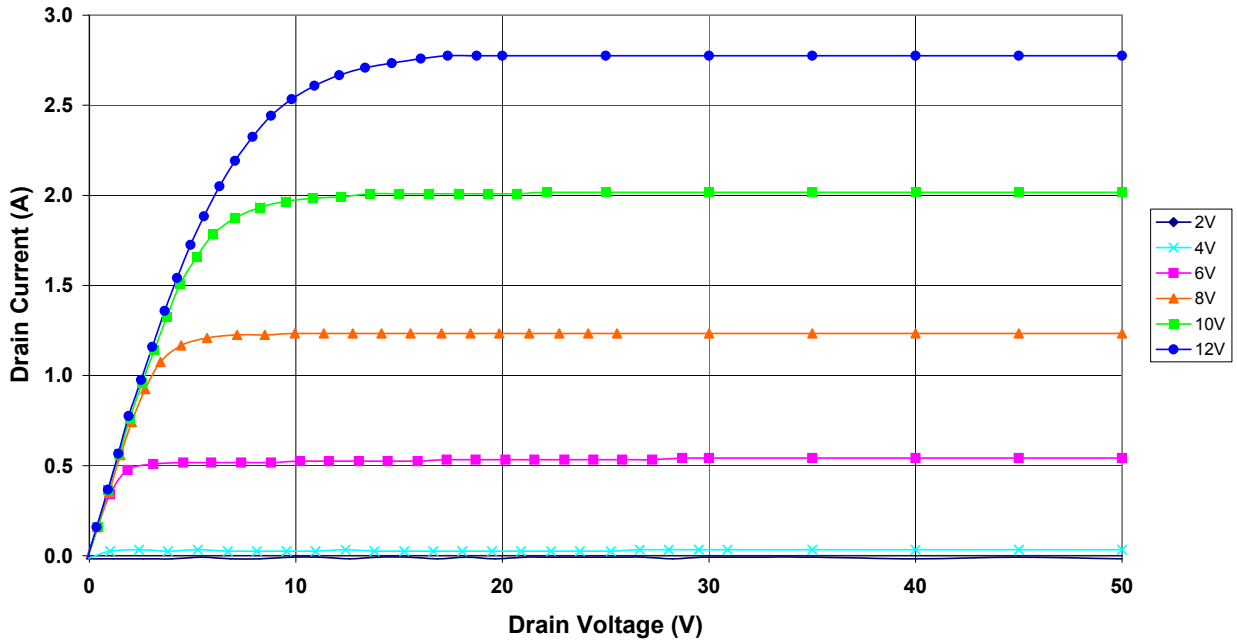

Figure 5 – Typical IV Characteristics.

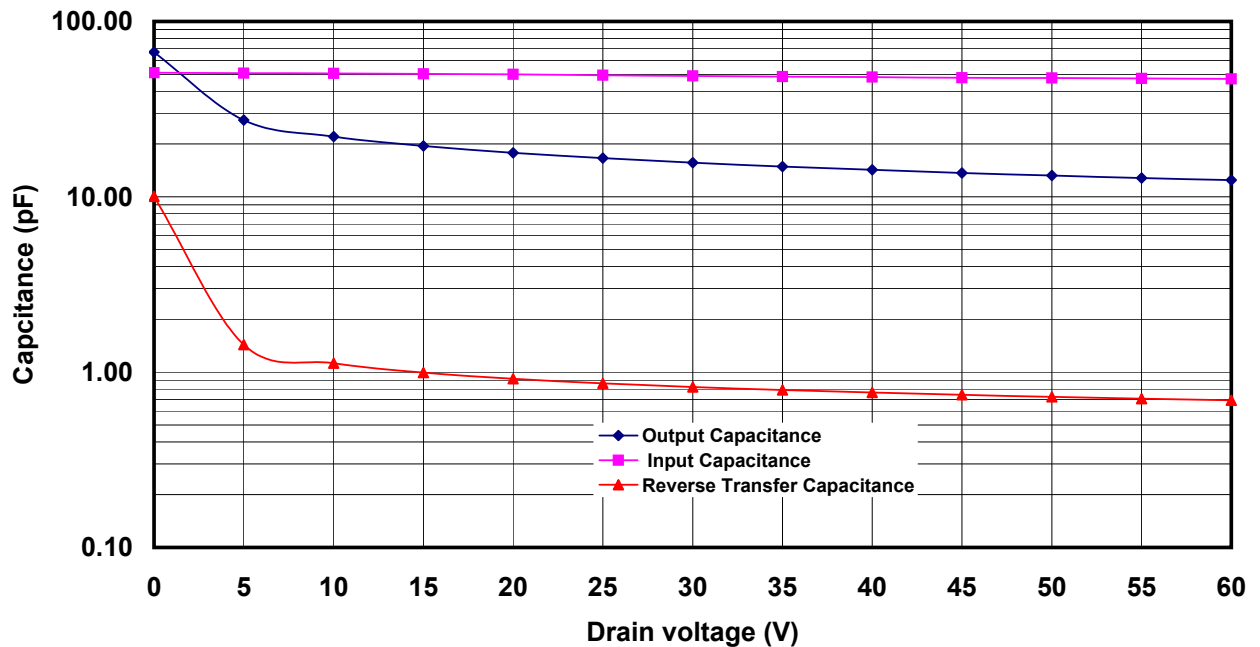
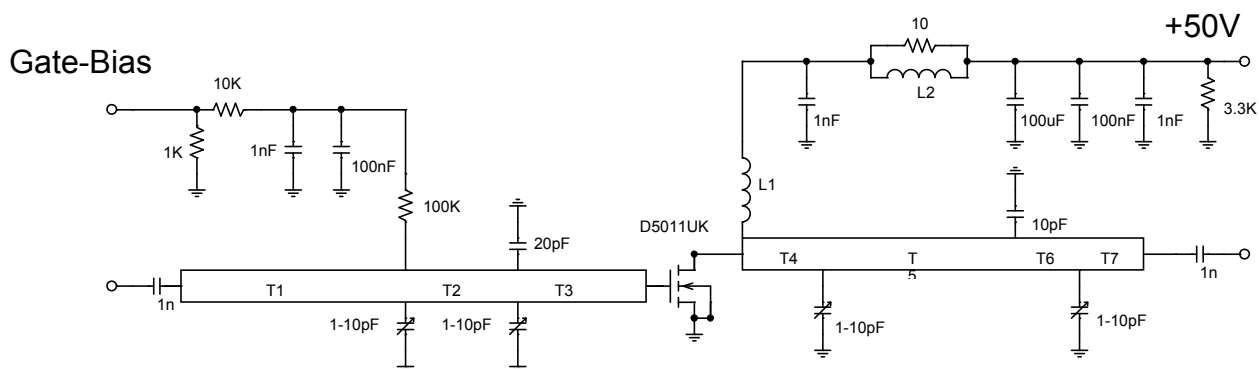

Figure 6 – Typical CV Characteristics.

Semelab Ltd reserves the right to change test conditions, parameter limits and package dimensions without notice. Information furnished by Semelab is believed to be both accurate and reliable at the time of going to press. However Semelab assumes no responsibility for any errors or omissions discovered in its use. Semelab encourages customers to verify that datasheets are current before placing orders.



D5011UK 500MHz TEST FIXTURE

Substrate 0.8mm FR4, Er=2.2

All microstrip lines W=2.2mm

T1 37.5mm
 T2 14.2mm
 T3 10mm
 T4 12.5mm
 T5 30mm
 T6 6mm
 T7 12.5mm

L1 5.5 turns 20swg enamelled copper wire, 7mm i.d.

L2 1.5 turns 24swg enamelled copper wire on Siemens B62152A7X 2 hole core

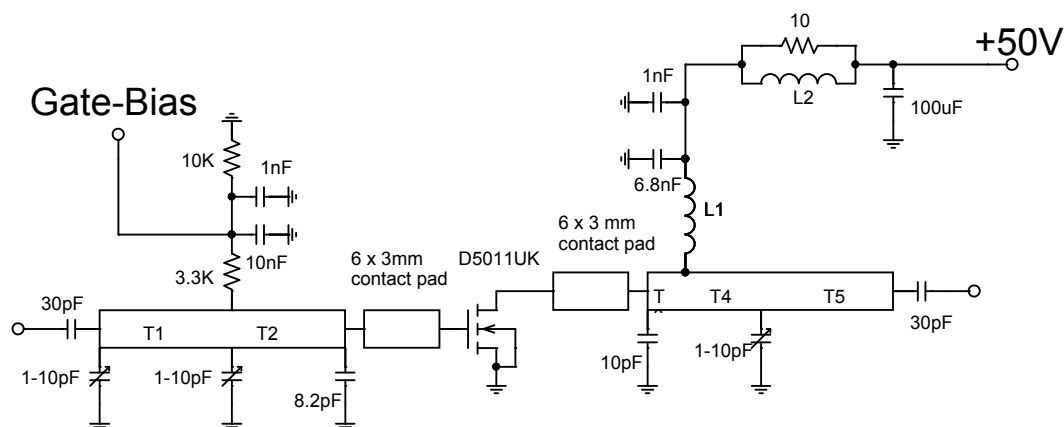

D5011UK 1GHz TEST FIXTURE

Substrate 0.8mm PTFE/glass, Er=2.5

All microstrip lines $W=2.2\text{mm}$

T1 35mm

T2 15mm

T3 4mm

T4 14 mm

T5 32mm

L1 7.5 turns 24swg enamelled copper wire, 3mm i.d.

L2 1.5 turns 24swg enamelled copper wire on ferrite core

Компания «Life Electronics» занимается поставками электронных компонентов импортного и отечественного производства от производителей и со складов крупных дистрибьюторов Европы, Америки и Азии.

С конца 2013 года компания активно расширяет линейку поставок компонентов по направлению коаксиальный кабель, кварцевые генераторы и конденсаторы (керамические, пленочные, электролитические), за счёт заключения дистрибьюторских договоров

Мы предлагаем:

- Конкурентоспособные цены и скидки постоянным клиентам.
- Специальные условия для постоянных клиентов.
- Подбор аналогов.
- Поставку компонентов в любых объемах, удовлетворяющих вашим потребностям.
- Приемлемые сроки поставки, возможна ускоренная поставка.
- Доставку товара в любую точку России и стран СНГ.
- Комплексную поставку.
- Работу по проектам и поставку образцов.
- Формирование склада под заказчика.
- Сертификаты соответствия на поставляемую продукцию (по желанию клиента).
- Тестирование поставляемой продукции.
- Поставку компонентов, требующих военную и космическую приемку.
- Входной контроль качества.
- Наличие сертификата ISO.

В составе нашей компании организован Конструкторский отдел, призванный помогать разработчикам, и инженерам.

Конструкторский отдел помогает осуществить:

- Регистрацию проекта у производителя компонентов.
- Техническую поддержку проекта.
- Защиту от снятия компонента с производства.
- Оценку стоимости проекта по компонентам.
- Изготовление тестовой платы монтаж и пусконаладочные работы.



Тел: +7 (812) 336 43 04 (многоканальный)

Email: org@lifeelectronics.ru