

ILD6150

Advanced Thermal Protection for High Power LEDs with 60V LED Driver IC ILD6150

Application Note

About this document

Scope and purpose

This Application Note introduces Infineon’s Hysteritic Buck DC/DC LED driver ILD6150 for general lighting application. It describes the demo board, performance as well as design ideas for various applications. The ILD6150 offers high efficiency, various protection features, superior dimming performance & reliability for high performance lighting system.

Intended audience

This document is intended for users, who wish to design high efficiency, high reliability lighting system with Infineon’s ILD6150/ILD6070 DC/DC LED driver.

Table of Contents

About this document	1
Table of Contents.....	1
1 Introduction	3
1.1 Features.....	3
1.2 Applications.....	4
1.3 Product Brief.....	4
2 Application Information.....	5
2.1 Schematic	5
2.2 PCB Layout.....	6
2.3 PCB Photo	6
3 Measurement Results	8
3.1 LED current vs supply voltage.....	8
3.2 Analog dimming	10
3.3 Contrast ratio.....	12
3.4 Over temperature protection	13
3.5 Efficiency	14
3.6 Transition from DC to switch mode	15
3.7 Soft start.....	16



Introduction

3.8 Over current protection.....18

3.9 PCB thermal resistance19

3.10 Thermal protection with NTC thermistor.....20

3.11 Slow start with additional PMOS for hot swapping21

3.12 Driving of LEDs with current more than 1.5 A by external MOSFETs22

4 References 23

Revision History..... 23

Introduction

1 Introduction

1.1 Features

- Wide input voltage range from 4.5 V to 60 V
- Capable to provide up to 1.5 A output current
- Up to 1 MHz switching frequency
- Soft-start capability
- Analog and PWM dimming possible
- Integrated PWM generator for analog dimming input
- Typical 3 % output current accuracy
- Very low LED current drift over temperature
- Undervoltage lockout
- Over current protection
- Thermally optimized package: PG-DSO-8-27
- Adjustable over temperature protection, reducing thermal load by decreasing the current

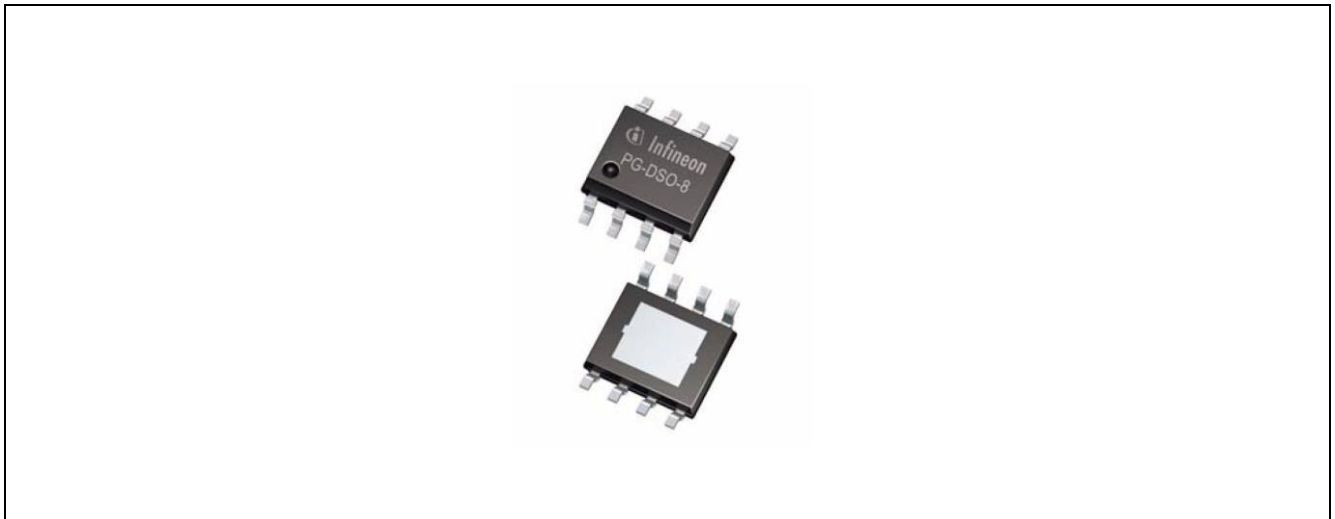

Figure 1 ILD6150

Introduction

1.2 Applications

- LED driver for general lighting
- Retail, office and residential downlights
- Street and tunnel lighting
- LED ballasts

1.3 Product Brief

The ILD6150 is a hysteretic buck LED driver IC for driving high power LEDs in general lighting applications with average currents up to 1.5 A.

The ILD6150 is suitable for LED applications with a wide range of supply voltages from 4.5 V to 60 V. A multifunctional PWM input signal allows dimming of the LEDs with an analog DC voltage or an external PWM signal. To minimize colorshifts of the LEDs an analog PWM voltage is converted to an internal 1.6 kHz PWM signal modulating the LED current.

The ILD6150 incorporates an undervoltage lock-out that will shut down the IC when the minimum supply voltage threshold is exceeded. The over-current protection turns off the output stage once the output current exceeds the current threshold. An integrated over-temperature protection circuit will start to reduce the LED current by internal PWM modulation once the adjustable junction temperature threshold of the IC is exceeded. Realizing a thermal coupling between LED driver and LEDs this feature eliminates the need of external temperature sensors as NTCs or PTCs.

The hysteretic concept the current control is extremely fast and always stable. A maximum contrast ratio of 3000:1 can be achieved depending of the dimensioning of the external components. The efficiency of the LED driver is remarkable high, reaching up to 98 % of efficiency over a wide range. The output current accuracy from device to device and under all load conditions and over temperature is limited to a minimum, making ILD6150 the perfect fit for LED ballasts.

Application Information

2 Application Information

In this application note, you will find more information about the demo board available for evaluation. The demo board is configured to have an output current of 1 A. The operating voltage range for the demo board can be from 4.5 V up to 60 V. The schematic, PCB layout and BOM list can be found in section 2.

2.1 Schematic

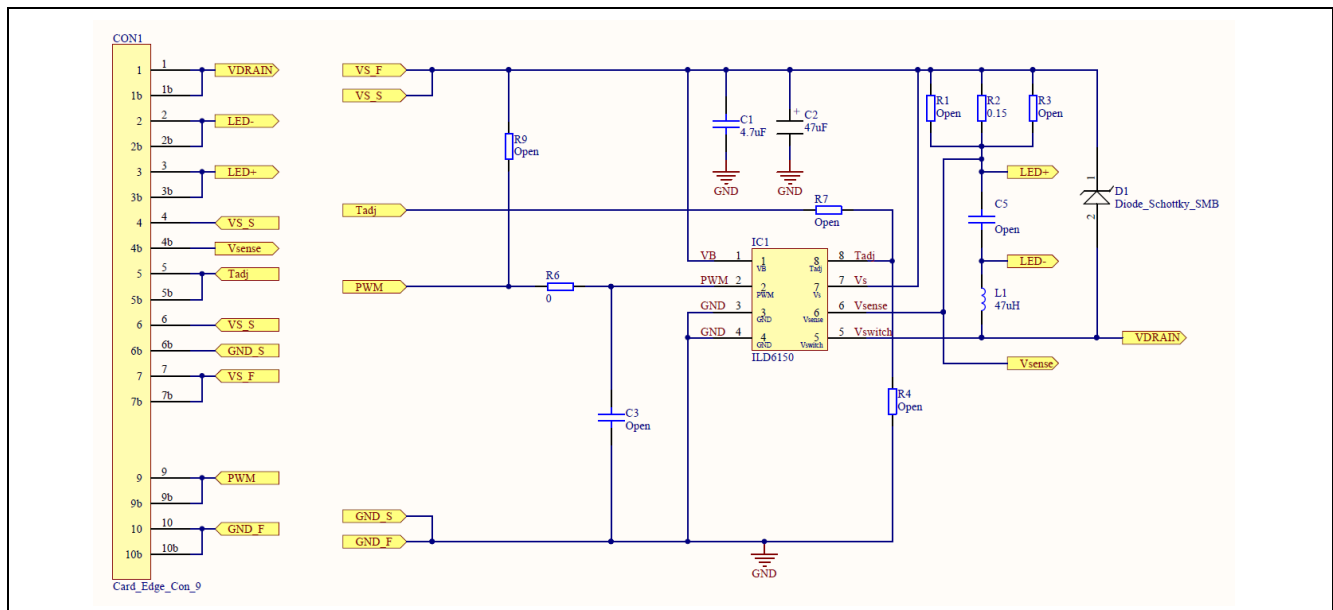

Figure 2 Schematic of the demonstration board

Application Information

2.2 PCB Layout

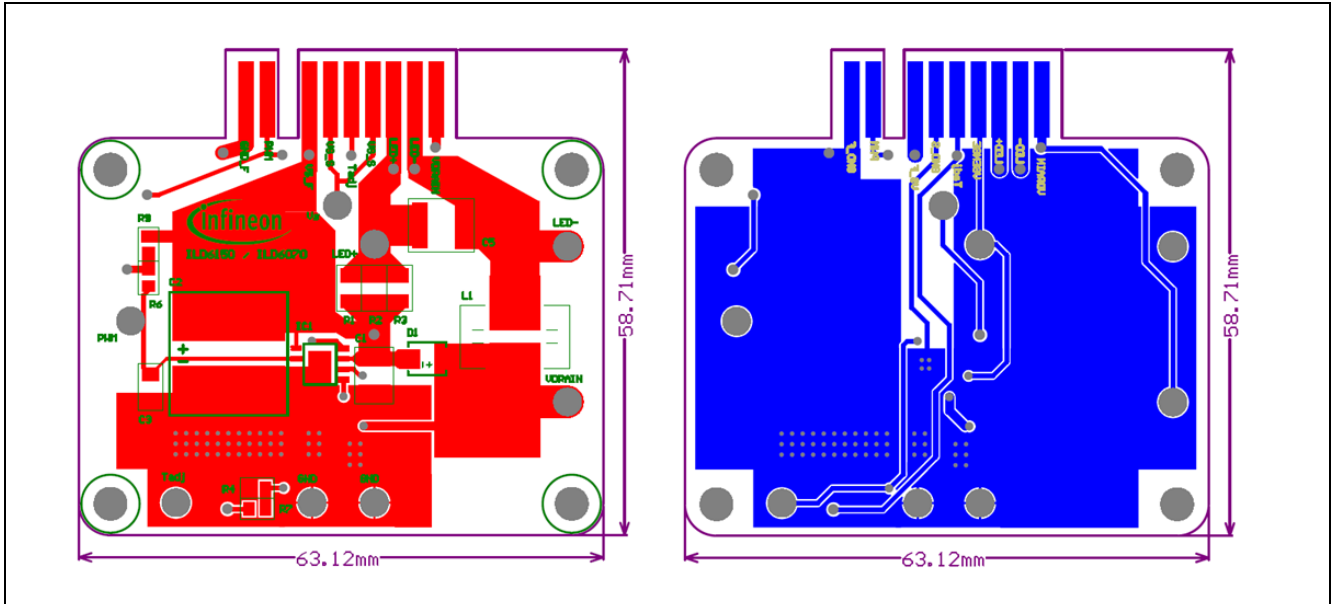

Figure 3 PCB layout of the demonstration board

2.3 PCB Photo

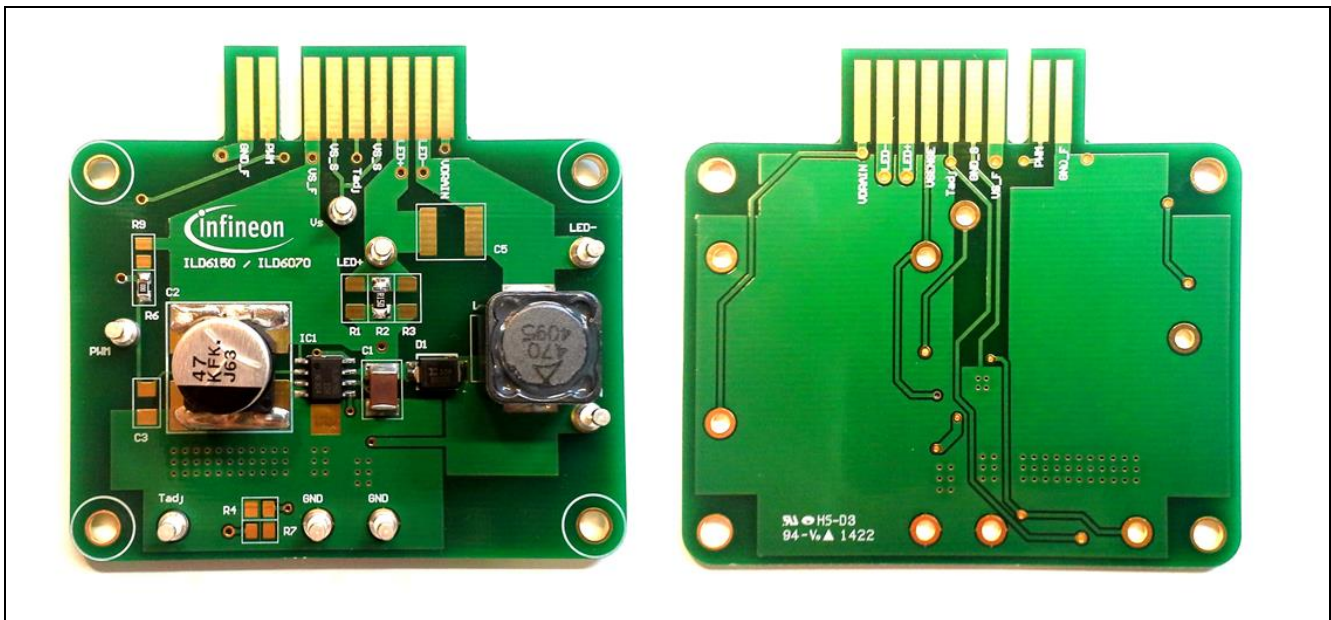

Figure 4 PCB photo of the demonstration board

Application Information

Table 1 Bill-Of-Materials

Symbol	Value	Unit	Size	Manufacturer	Comment
IC1	ILD6150		DSO-8	INFINEON	Hysteretic Buck controller and LED driver
R1	Open	Ω	1206		Current sense resistor
R2	0.15	Ω	1206		Current sense resistor
R3	Open	Ω	1206		Current sense resistor
R4	Open	Ω	0805		Resistor for TSD adjustment
R6	0	Ω	0805		Series resistor for PWM pin
R7	Open	Ω	0805		Series resistor for Tadj pin
R9	Open	Ω	0805		Pull-up resistor for PWM pin
C1	4.7	μF	1812	TDK	C4532X7S2A475M, Ceramic, 100 V
C2	47	μF	G	PANASONIC	EEEFK1K470P, Electrolytic, 80 V
C3	Open	μF	1206		Filter capacitor for PWM pin
C4	Open	μF	1206		Filter capacitor for VB pin
C5	Open	μF	2220		Current ripple reduction capacitor
J1	0	Ω	0805		Jumper
D1	B2100-13-F		SMB	DIODES INC.	Schottky diode, 100 V, 2 A
L1	47	μH	12 x 12 mm	EPCOS	Shielded Power Inductor

The demo boards are available on request. Please contact your local sales representative for the updated information of the demo board's status.

Measurement Results

3 Measurement Results

3.1 LED current vs supply voltage

The average LED current is determined by the value of the external current sense resistor (R_{sense}), formed by R1, R2 and R3 connected between V_s and V_{sense} . For ILD6150, the mean current sense threshold voltage is 152mV. The equation that determines the output LED current is given:

$$I_{OUT} = \frac{V_s - V_{sense}}{R_{sense}} = \frac{152mV}{R_{sense}}$$

The target current setting for the demo board is 1 A. Based on above equation the R_{sense} is equal to 0.152 Ω . A resistor at the value of 0.15 Ω is chosen for the demo board.

The measurement results in this session are based on the condition below, unless otherwise specified:

Table 2 Typical condition for measurement

Vs	Rsense	Inductance	LED load
48 V	0.15 Ω	47 μ H	12 pcs

Figure 5 shows the actual operating waveforms. The actual measured V_{sense} average voltage under this condition is 150 mV, and the LED current is 1 A. The switching frequency is 467 kHz and the internal DMOS transistor on duty-cycle is 73.8 %.

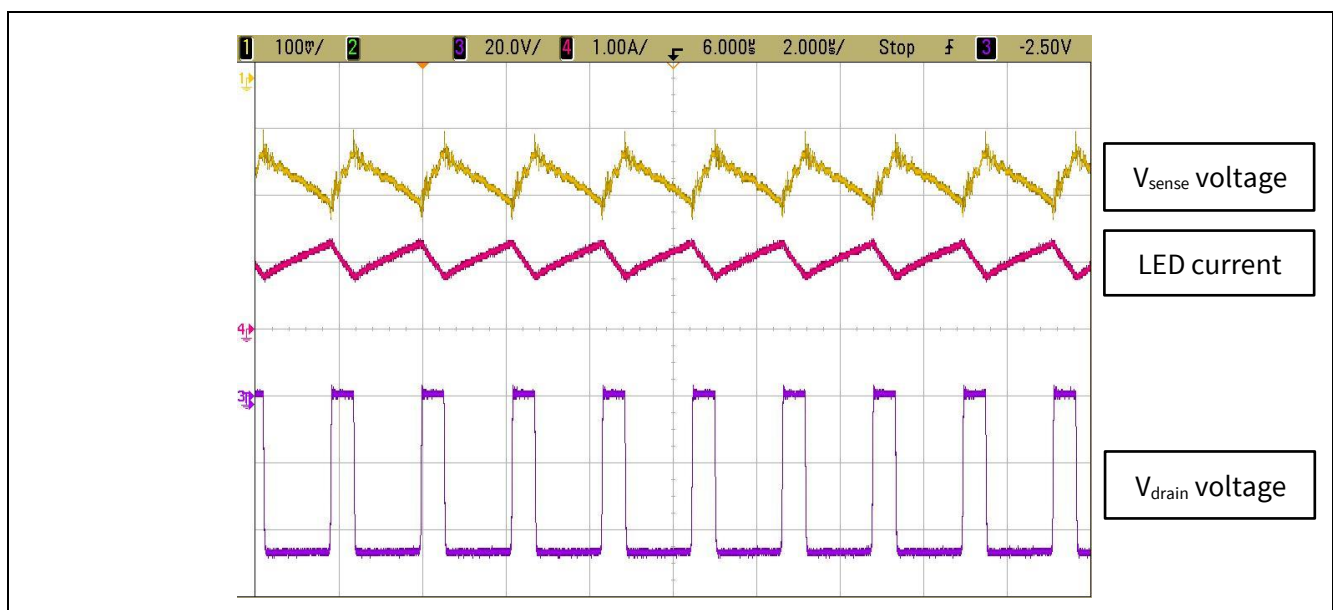

Figure 5 Normal operation waveforms

Measurement Results

The ILD6150 offer a high accuracy of output current despite the changes in supply voltage. Figure 6 shows the output current vs supply voltage from the range of 40 V to 60 V. Over the supply range from 40 V to 60 V, the output LED current only deviated by 2 %.

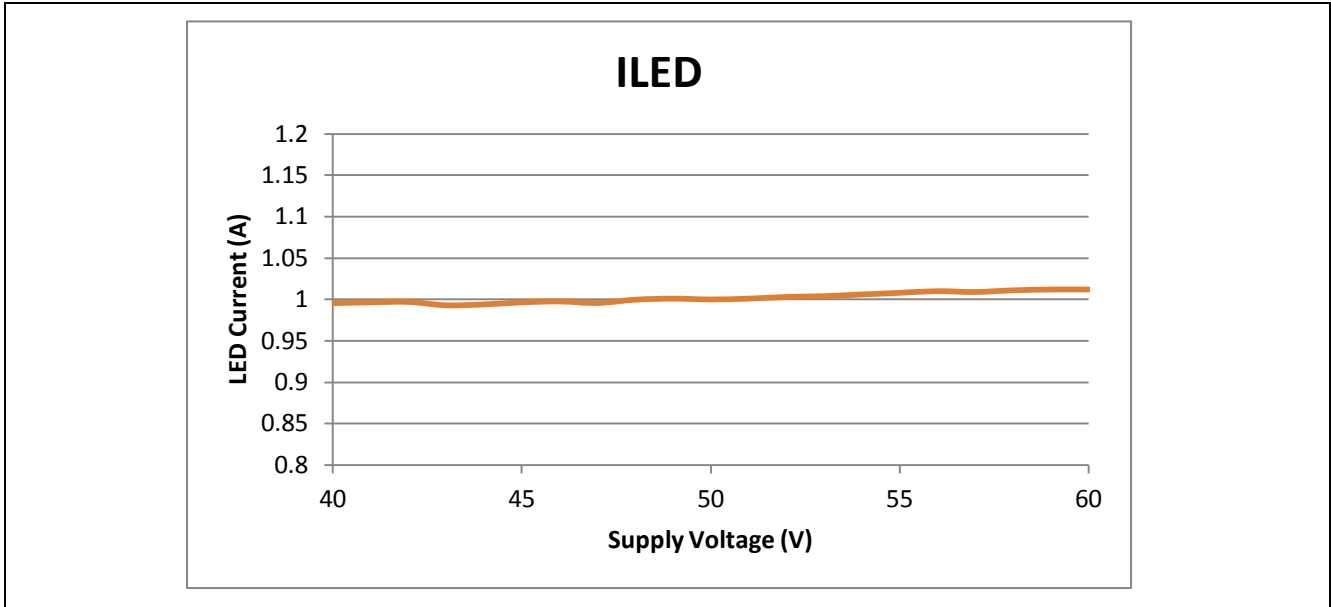

Figure 6 Output LED current vs supply voltage

Measurement Results

3.2 Analog dimming

The multifunctional PWM input pin allows dimming of the LEDs with an analog DC voltage. To minimize the colorshifts of the LEDs, the analog DC voltage is converted into a 1.6 kHz PWM signal modulating the LED current.

The linear range of the analog dimming is from 0.5 V to 2.5 V. LEDs is fully turned on for voltage above 2.5 V and fully turned off for voltage below 0.5 V.

Figure 7 shows the analog dimming ratio vs PWM pin voltage.

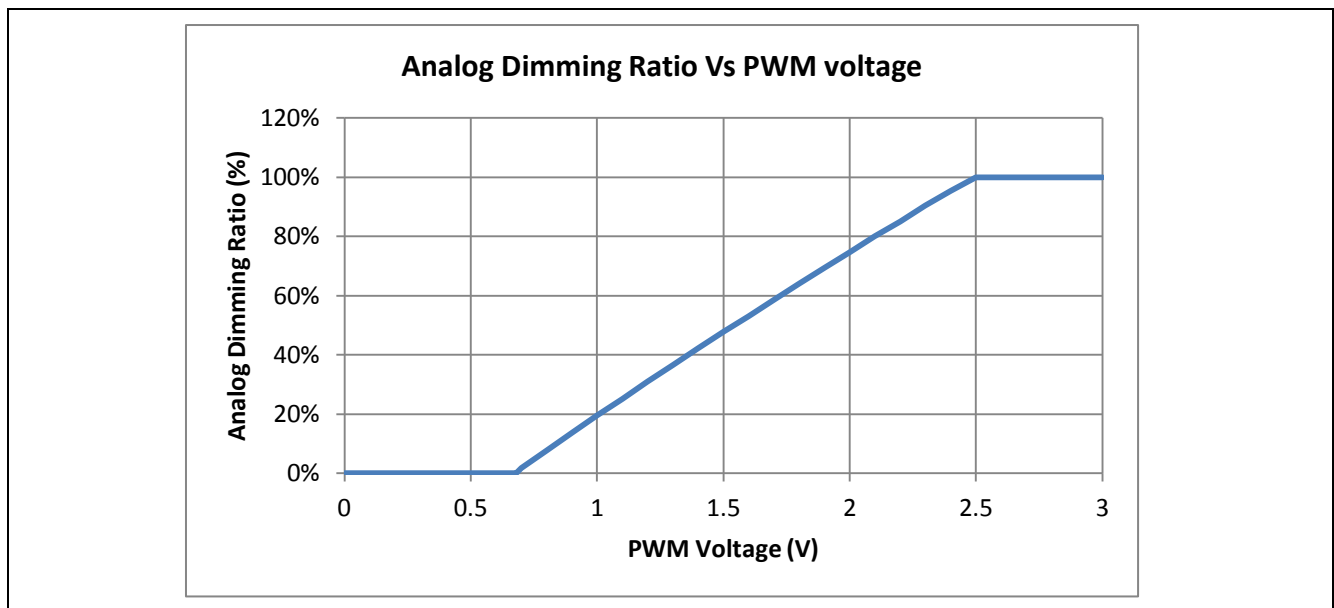

Figure 7 Analog dimming ratio vs PWM pin voltage

Figure 8 and Figure 9 show the waveforms while the PWM pin voltage is equal to 1V and 2V. The output current is modulated by the internal PWM signal at 1.6 kHz.

Measurement Results

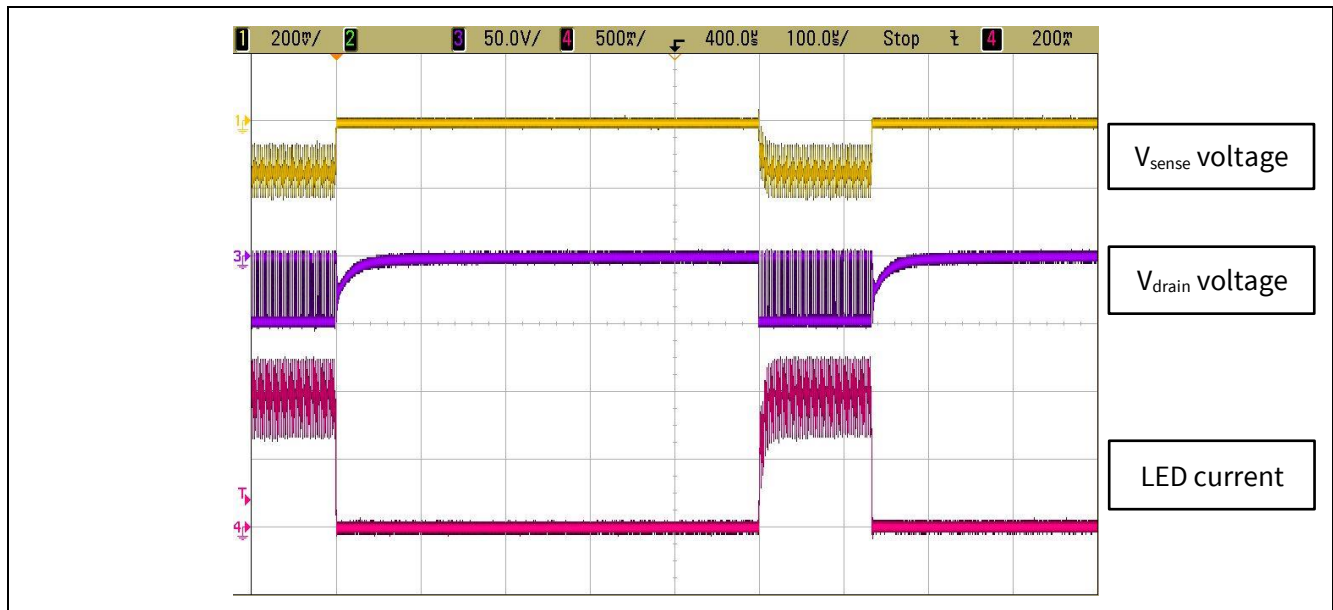

Figure 8 Output waveforms at $V_{PWM} = 1\text{ V}$

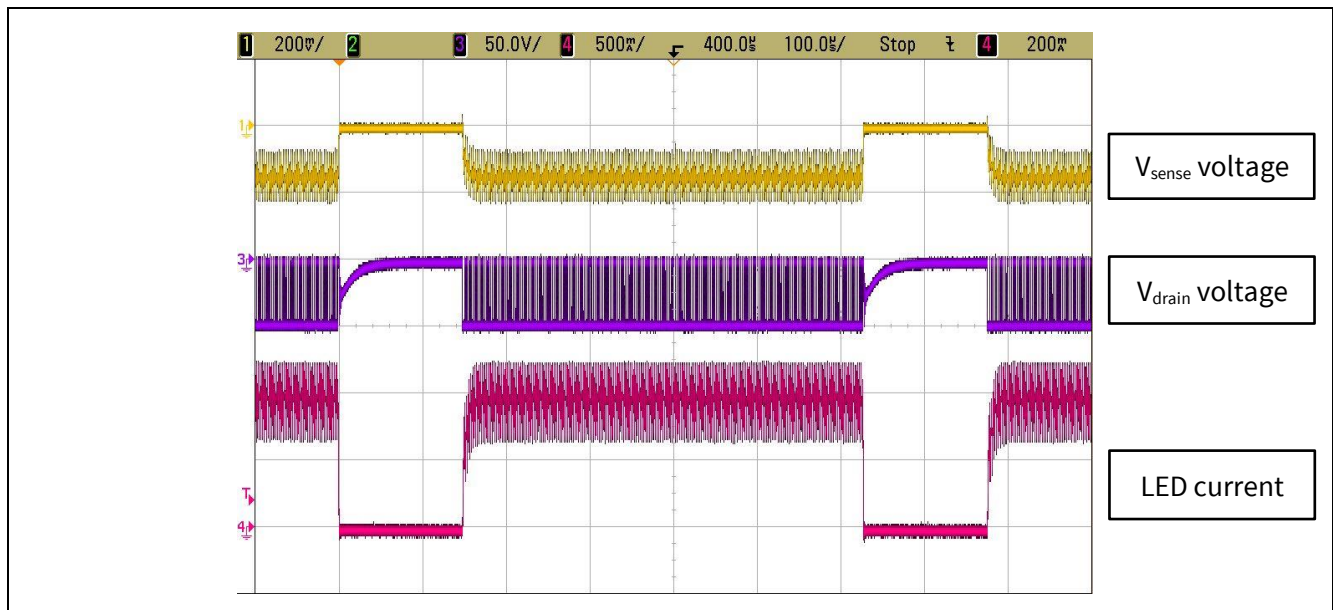

Figure 9 Output waveforms at $V_{PWM} = 2\text{ V}$

The multifunctional PWM pin allows both analog and PWM input for dimming control. However, it should not be operated with combining both analog and PWM input. For example, input a PWM signal with the input voltage of low level = 0 V and high level = 1.5 V, the output current will be modulated by the internal and external PWM frequency.

Measurement Results

3.3 Contrast ratio

The contrast ratio of a system depends on the dimensioning of the external components, PWM frequency as well as supply voltage. The definition of the contrast ratio (CR) is given as:

$$CR = \frac{1}{D_{MIN}}$$

Where

$$D_{MIN} = \frac{t_D + t_{SU}}{T}$$

$$T = \frac{1}{f_{PWM}}$$

Figure 10 shows the relationship of the PWM and LED current waveforms.

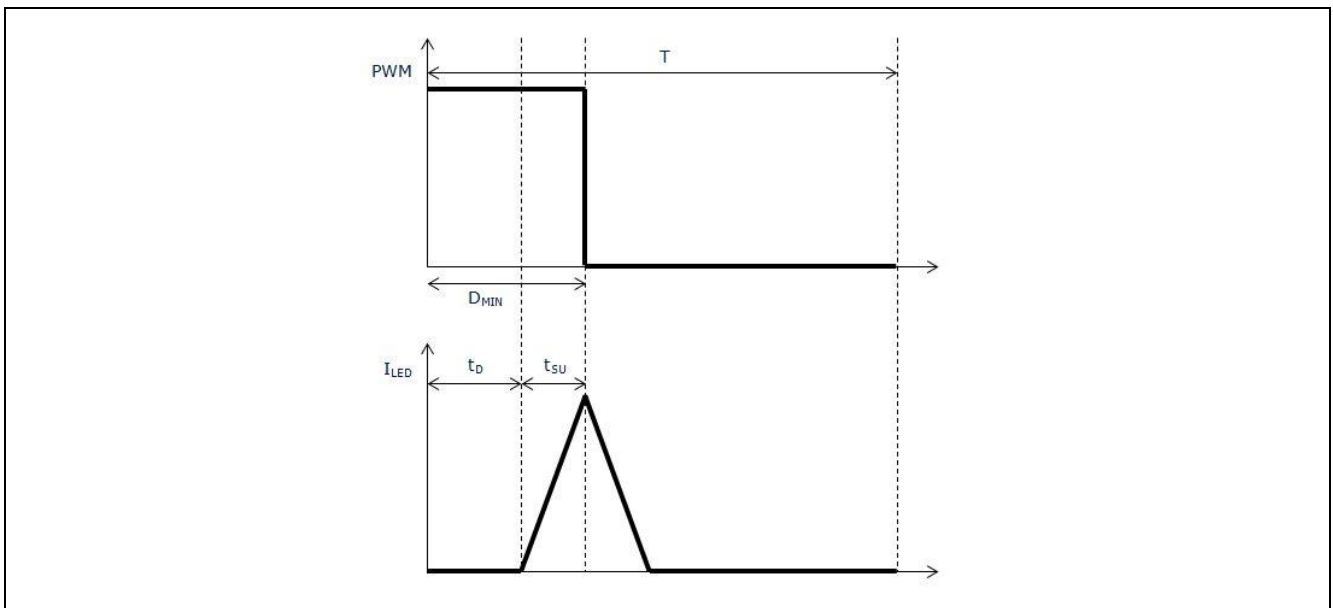

Figure 10 Contrast ratio definitions

Figure 11 shows the PWM and LED current waveform and Table 3 shows the measurement results for the demo board.

Measurement Results

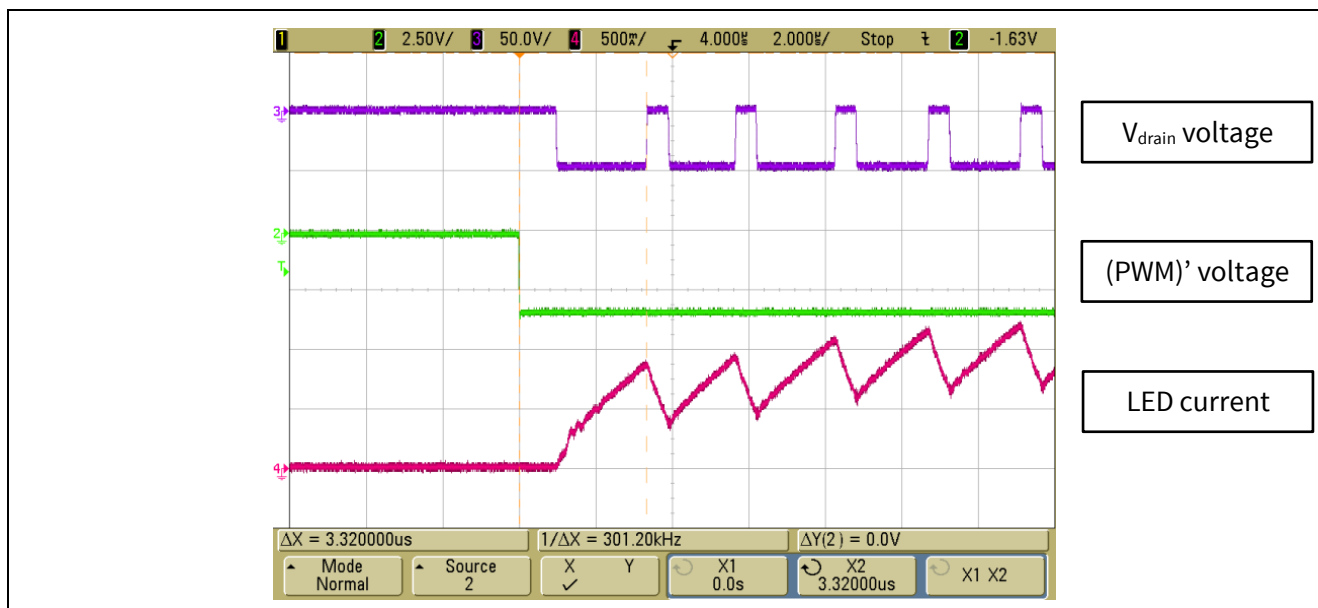

Figure 11 Contrast ratio – PWM and LED current waveforms

Table 3 Contrast ratio calculation

f_{PWM}	T	t_b	t_{su}	D_{MIN}	CR
500 Hz	2 ms	1 μ s	2.32 μ s	1.66×10^{-3}	600
200 Hz	5 ms	1 μ s	2.32 μ s	6.64×10^{-4}	1500
100 Hz	10 ms	1 μ s	2.32 μ s	3.32×10^{-4}	3000

With the PWM frequency of 500 Hz, the contrast ratio of 600:1 can be achieved. On the other hand, with the PWM frequency of 100 Hz, the contrast ratio of 3000:1 can be achieved.

3.4 Over temperature protection

The ILD6150 feature with an integrated over temperature protection (OTP) circuit will start to reduce the LED current by internal PWM modulation once the adjustable junction temperature threshold of the IC is exceeded. The OTP profile can be adjusted by using a resistor connect between between the T_{adj} pin and GND pin.

Figure 12 shows the measurement results of OTP profile with output LED current’s duty cycle vs junction temperature of the ILD6150 by using 0 Ω , 10 k Ω , 20 k Ω , 35 k Ω and open at T_{adj} pin.

With the adjustable OTP, it offers a great flexibility which the starting point of the current reduction at high temperature can be designed according to LED lamp requirement. This new OTP feature offers a great flexibility for the adjustable of the roll-off temperature and eliminates the use of the NTC/PTC thermistor in the system.

Measurement Results

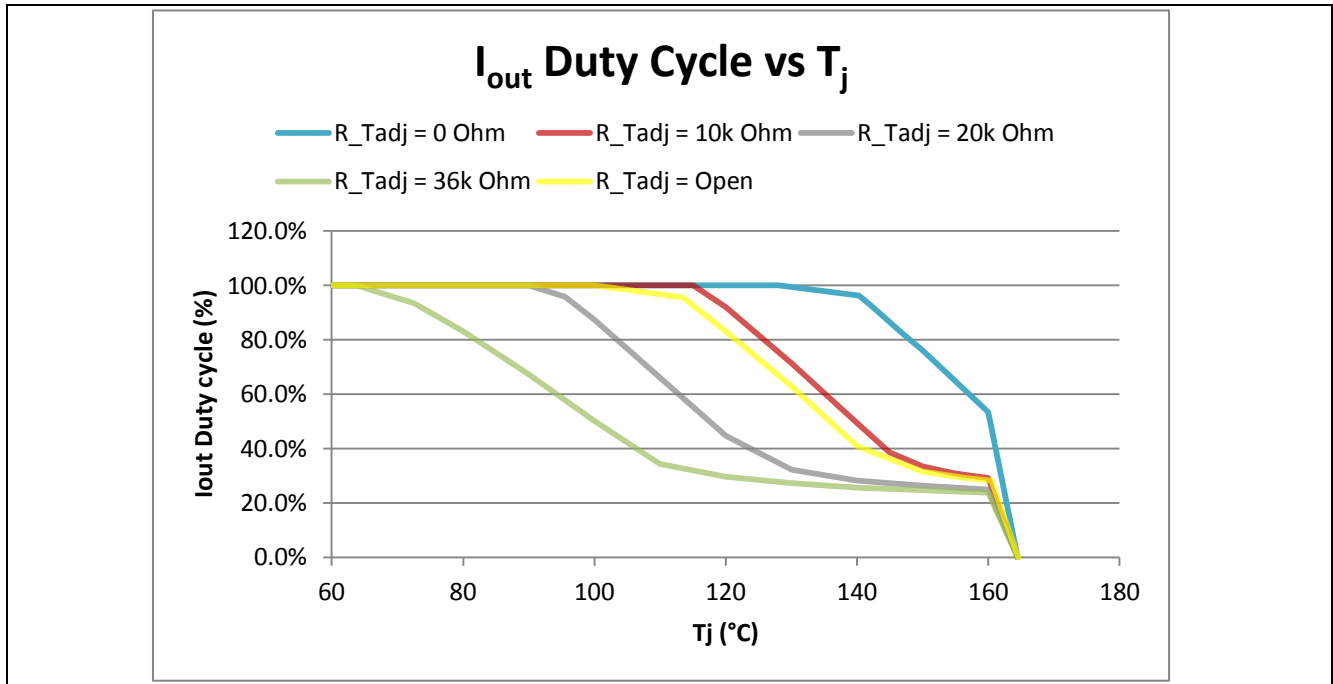

Figure 12 Over temperature protection

3.5 Efficiency

The measurement results of efficiency of the system for V_s = 40 V to 60 V can be found in Figure 13. For 12pcs LED as a load, the efficiency is keep above 92 % to 96 % in the voltage range from 40 V to 60 V.

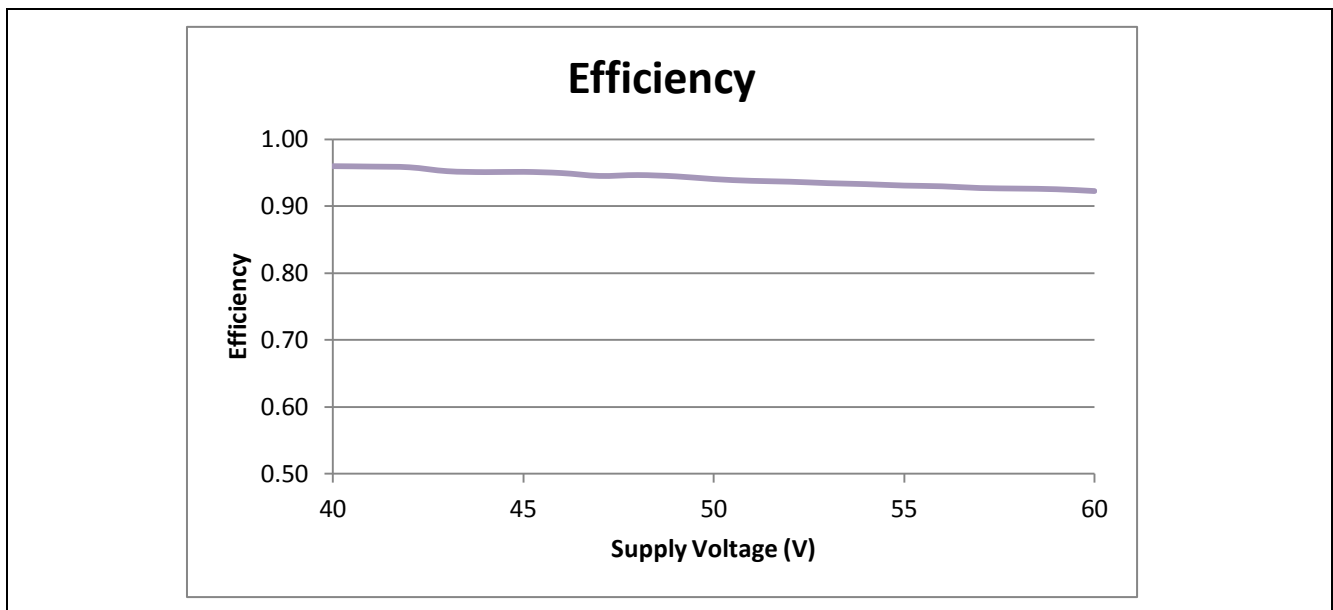

Figure 13 Efficiency vs Supply voltage

Measurement Results

3.6 Transition from DC to switch mode

While the input supply voltage is lesser or close to the LEDs load forward voltage’s requirement, the output current is not reaching the target setting value. Under this condition, the ILD6150 is working in the DC mode, meaning that the DMOS is fully turned on and no switching activities.

One of the nice features that ILD6150 offer is during the transition from the DC mode to switch mode, it will not have any overshoot in the output current.

Figure 14 shows the LED current measurement results for the entire operating voltage range from 4.5 V to 60 V, $R_{sense} = 0.1 \Omega$ with different number of LEDs as load.

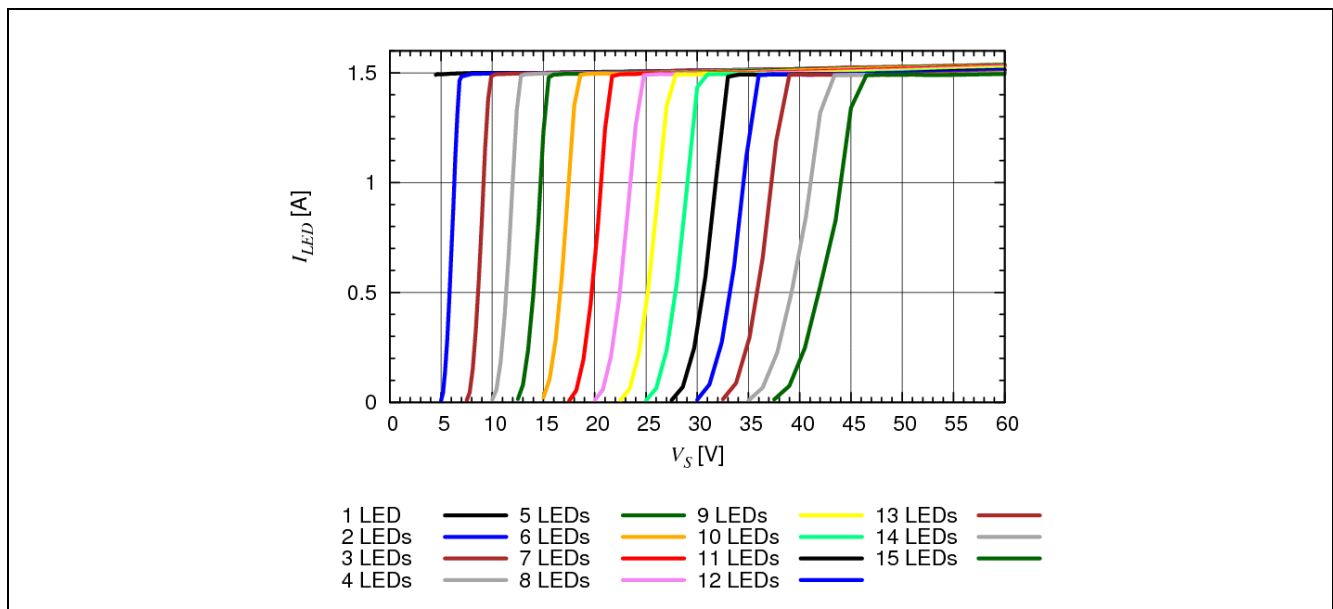

Figure 14 LED current at the transition from DC to switch mode

Measurement Results

3.7 Soft start

The soft start of the LED light can be achieved by adding a capacitor at the PWM pin. The ILD6150 having an internal current source of 18 μA will charge up the capacitor at the PWM pin from 0 V to 4.7 V linearly. The soft start timing can be calculated using below equation:

$$i = C \frac{dv}{dt}$$

$$\therefore dt = \frac{C \times dv}{i}$$

Refer to the specification of the analog dimming; the linear range of the output current from 0 % to 100 % is within the range from 0.67 V to 2.43 V. Hence the value of dv is equal to 1.76 V and the current i is equal to 18 μA .

For example if a capacitor in the value of 10 μF is connected to the PWM pin, the soft start timing for the light output from 0 % to 100 % require 0.978 second.

Figure 15 shows the LED current waveform which modulated by the PWM signal from 0 % to 100 % output. The actual measurement result for the soft start is 1.08 second. Figure 16 shows the average of the LED current during the soft start-up phase.

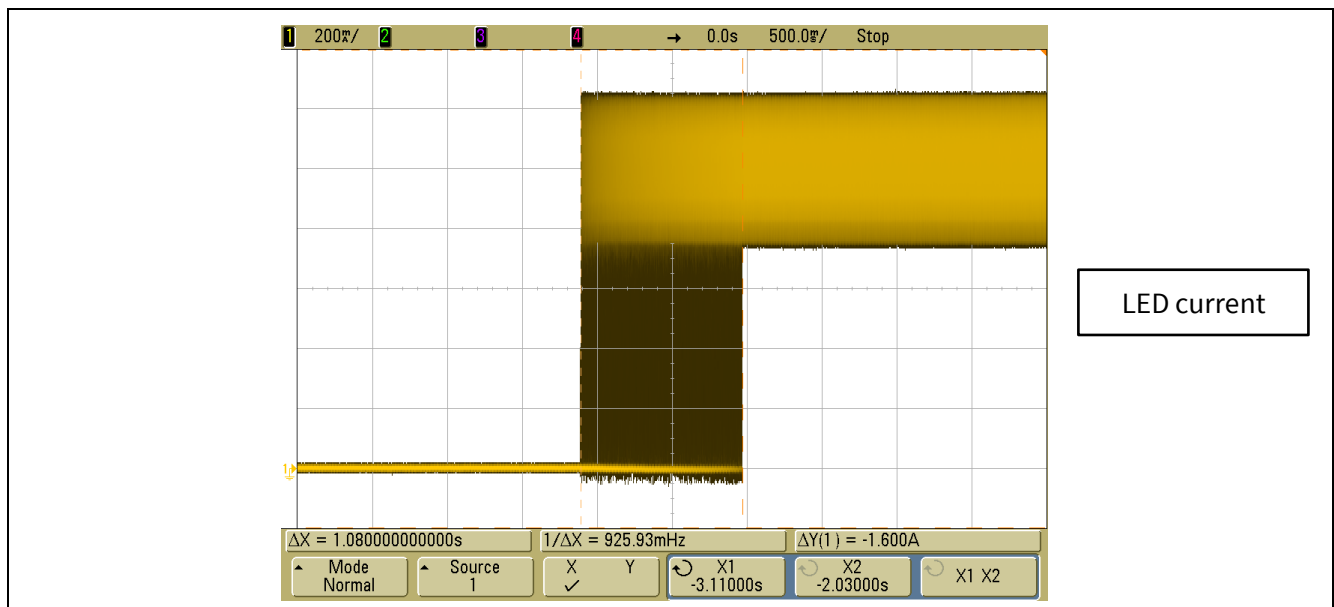

Figure 15 Soft-start with 10 μF at the PWM pin

Measurement Results

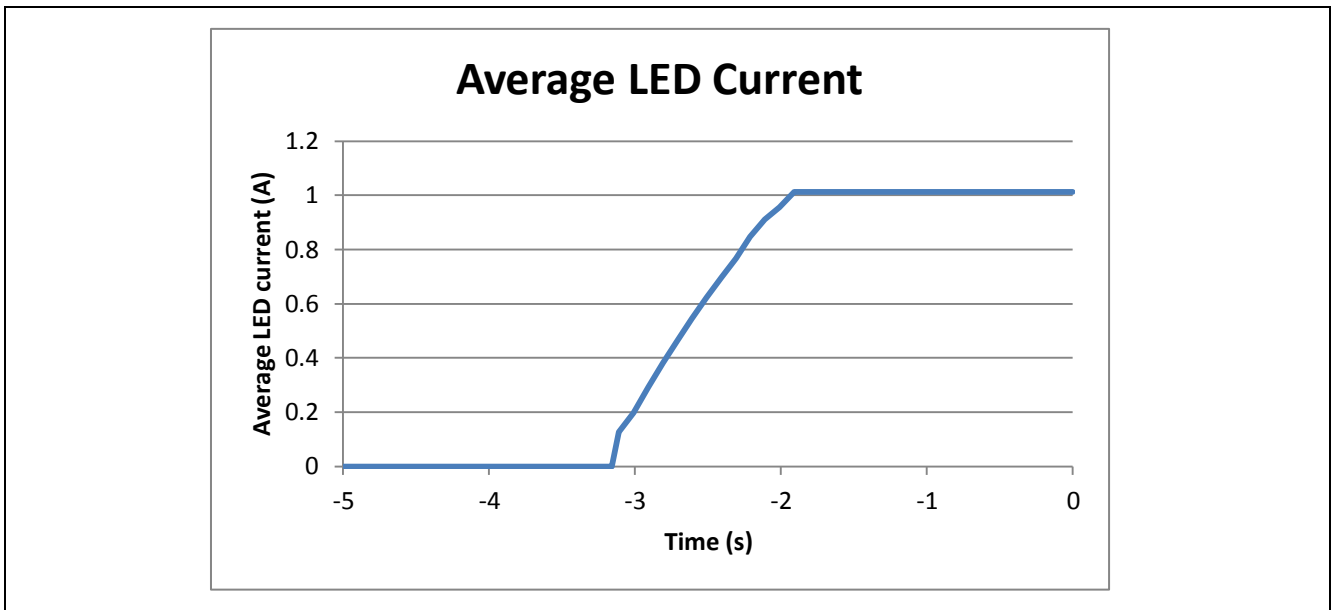

Figure 16 Average of LED current during the soft start with 10 μ F at the PWM pin

Measurement Results

3.8 Over current protection

The ILD6150 feature with over current protection (OCP), in case when the R_{sense} is shorted accidentally, the driver will not be damaged by the large current flowing through the internal MOSFET. However, the over current protection feature does not guarantee the protection for the LEDs load. This is because different type of LEDs having different maximum rating on the current specification. The threshold current to trigger the OCP for ILD6150 is 2.5 A.

Figure 17 below shows the waveforms where the ILD6150 in the OCP mode. The R_{sense} is shorted, the LEDs load is replaced by a $3\ \Omega$ resistor and input supply voltage is 20 V.

During the OCP, the MOSFET will be turned off for about $60\ \mu\text{s}$ when the 2.5 A current threshold is reached.

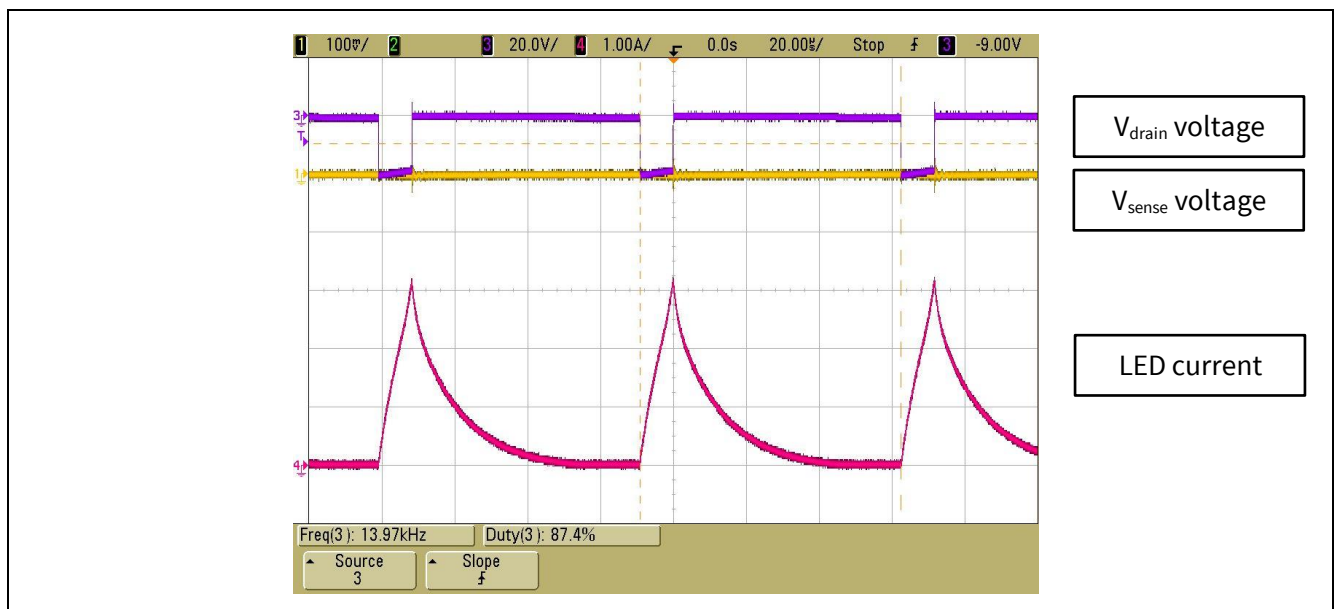

Figure 17 Over current protection waveforms

Measurement Results

3.9 PCB thermal resistance

As a reference for designing the surface area for the grounding for the PCB using FR4 to achieve a certain thermal resistance between desired solder point temperature and expected ambient temperature, the following chart can be used.

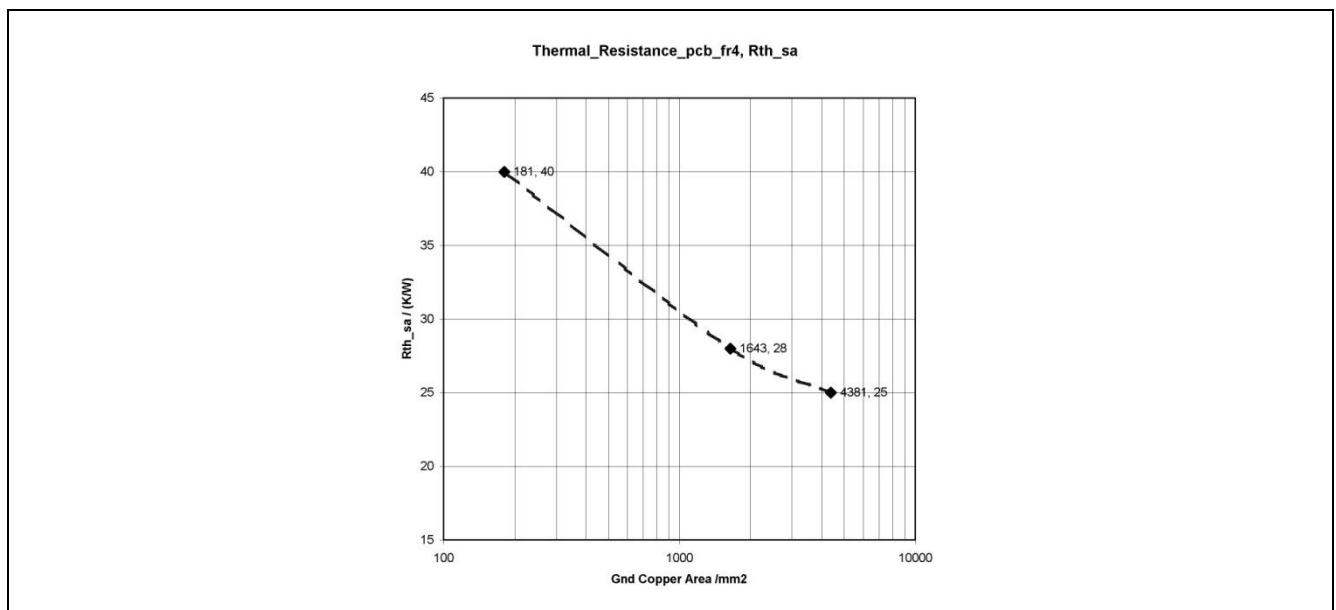

Figure 18 Thermal resistance of PCB-FR4 versus ground copper area

The data in the above Figure 18 were measured with the following conditions:

- Two copper layers.
- 2 oz copper (70 μm thick) and board thickness of about 1.6 mm.
- FR4 material.
- No forced convection.
- No heat sink.
- No special mask opening for improved heat dissipation.
- In the chart, only three points are marked by diamond symbol. These are measured data. The broken line represents intermediate points which can be derived by linear interpolation.

Measurement Results

3.10 Thermal protection with NTC thermistor

The build in thermal protection offers flexibility for the adjustment of roll-off temperature. However, the ILD6150 is required to be placed near the LEDs lamp to optimize this feature.

In case where the ILD6150 is placed far away from the LEDs (for example, in the electronic control gear), an external NTC thermistor can be used to realize the thermal protection. The NTC thermistor shall be placed near to the LEDs to sense the temperature of the LEDs accurately. Please refer to Figure 19 for the schematic. When the NTC thermistor is heated up, the resistance of the thermistor will drop and the voltage on the PWM pin will decrease. As the DC voltage on the PWM pin decreased, the output LED current will be reduced by analog dimming and the temperature of the LEDs will be reduced also.

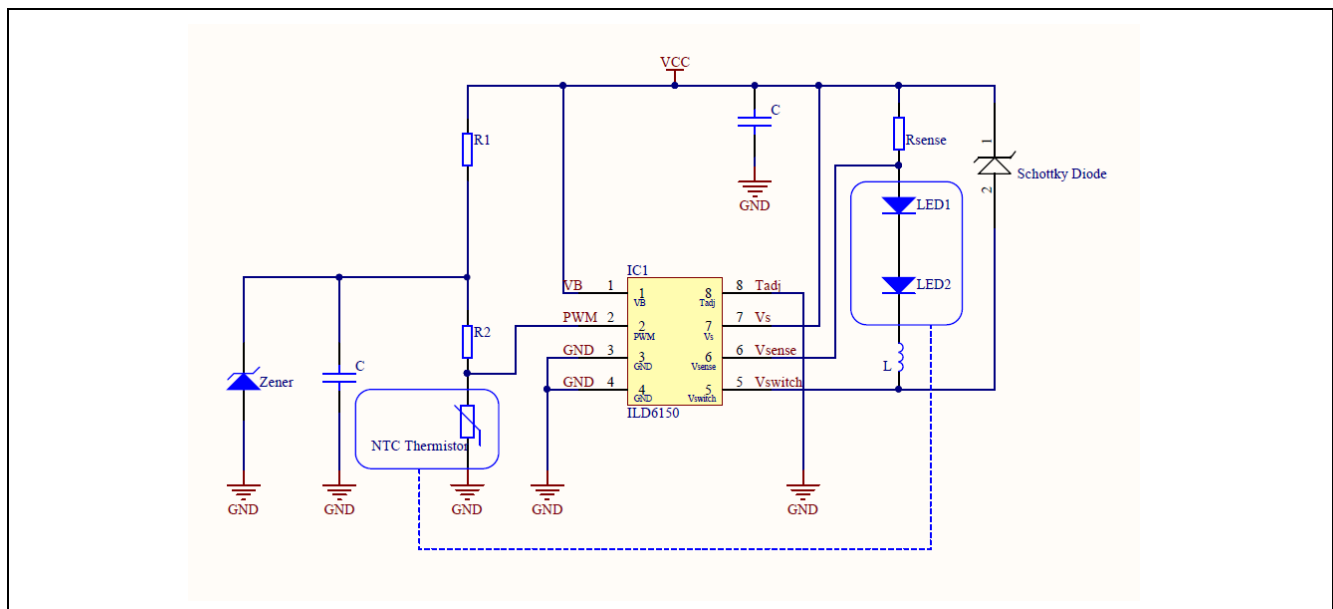

Figure 19 Thermal sensing with NTC thermistor

Measurement Results

3.11 Slow start with additional PMOS for hot swapping

In the event where the LED light is require for hot swappable, there is a possibility where the rise time of V_s voltage is very fast. In order to prevent the fast rising time of the V_s which might trigger the internal ESD structure of the ILD6150, it is require a larger blocking capacitor on the V_s pin as described in the datasheet, page 10.

To address this, with an additional PMOS by means of limiting the current flow during the hot swapping allows user to choose a smaller size of ceramic capacitor. Figure 20 shows the option of using the PMOS for hot swapping application with a smaller size of capacitor.

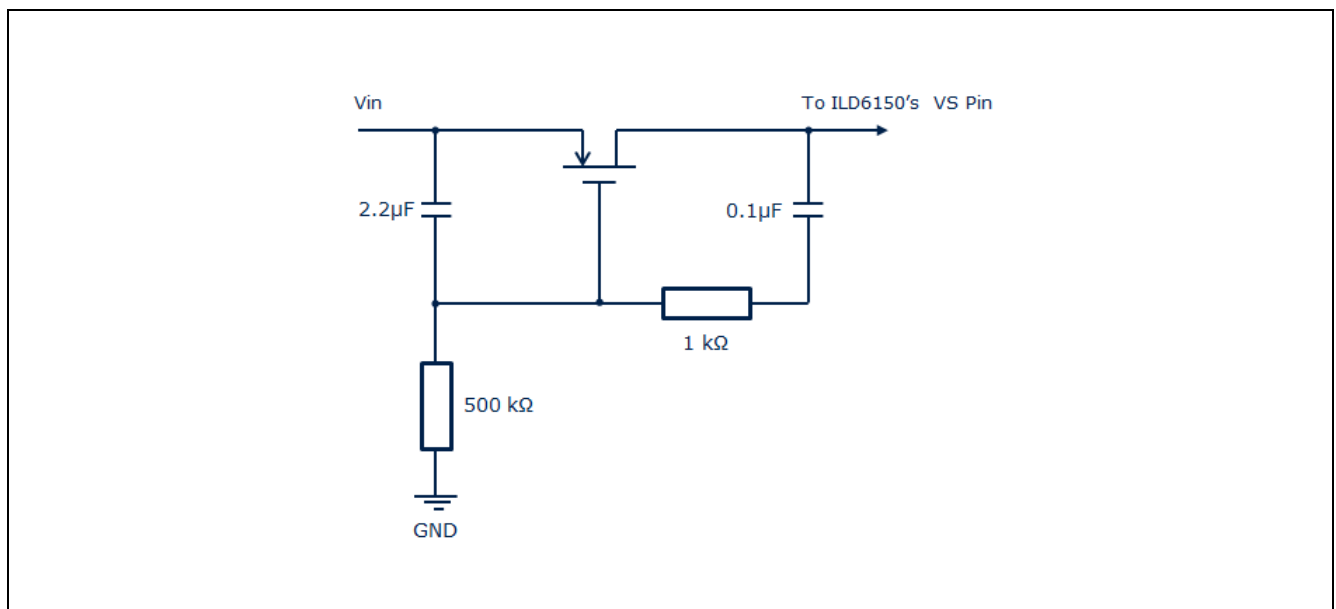

Figure 20 Schematic of additional PMOS circuitry

Measurement Results

3.12 Driving of LEDs with current more than 1.5 A by external MOSFETs

The build-in MOSFET in the ILD6150 limits the output current up to 1.5 A. In the situation where the LED current of more than 1.5 A is needed, the ILD6070 can be used as a controller to drive an external MOSFET in order to boost the output current. This chapter describes the design idea on how to achieve higher output current for driving high power LEDs.

Figure 21 shows the schematic example of applying ILD6070 as a controller and additional components. The extra components required are: 2 pull-up resistors, 2 zener diodes and 2 MOSFETs. The zener diodes at the gates are to prevent the Vgs breakdown of the external MOSFETs as the Vs could be higher than the maximum rating of the MOSFETs.

The ILD6070 is a DC/DC LED driver with build in MOSFET up to 700 mA. For more information about the ILD6070, refer to next chapter - References for the link to datasheet.

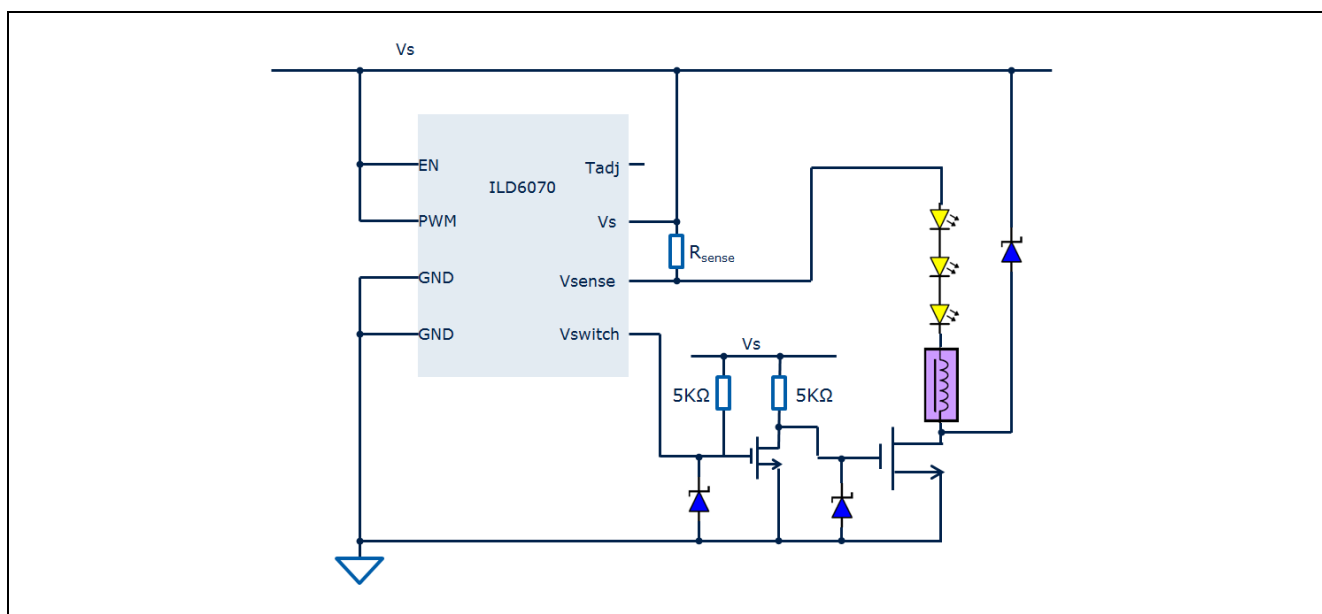

Figure 21 ILD6070 as a controller to drive external MOSFETs for high power LED application

References

4 References

Please refer to the ILD6150 Datasheet for more information:

[Link to ILD6150 Data sheet](#)

Please refer to the ILD6150 Datasheet for more information:

[Link to ILD6070 Data sheet](#)

Revision History

Major changes since the last revision

Page or Reference	Description of change
Revision 1.0	
Figure 2	Schematic updated
Revision 1.1	
Table 1	EN pin changes to VB pin
Figure 2	Schematic updated
Figure 3	Schematic updated
Figure 4	Schematic updated
Revision 2.1	
16	Additional – Soft start
17	Additional – Over current protection
13	Additional – Contrast ratio waveforms and CR at 200Hz
1	Title description
5	Features description
18	Additional – PCB thermal resistance
19	Additional – Thermal protection with NTC thermistor
Revision 2.2	
21	Additional - Slow start with additional PMOS for hot swapping
22	Additional - Driving of LEDs with current more than 1.5 A by external MOSFETs

Trademarks of Infineon Technologies AG

AURIX™, C166™, CanPAK™, CIPOS™, CIPURSE™, CoolGaN™, CoolMOS™, CoolSET™, CoolSiC™, CORECONTROL™, CROSSAVE™, DAVE™, DI-POL™, DrBLADE™, EasyPIM™, EconoBRIDGE™, EconoDUAL™, EconoPACK™, EconoPIM™, EiceDRIVER™, eupec™, FCOS™, HITFET™, HybridPACK™, ISOFACE™, IsoPACK™, i-Wafer™, MIPAQ™, ModSTACK™, my-d™, NovalithIC™, OmniTune™, OPTIGA™, OptiMOS™, ORIGA™, POWERCODE™, PRIMARION™, PrimePACK™, PrimeSTACK™, PROFET™, PRO-SIL™, RASIC™, REAL3™, ReverSave™, SatRIC™, SIEGET™, SIPMOS™, SmartLEWIS™, SOLID FLASH™, SPOC™, TEMPFET™, thinQ™, TRENCHSTOP™, TriCore™.

Other Trademarks

Advance Design System™ (ADS) of Agilent Technologies, AMBA™, ARM™, MULTI-ICE™, KEIL™, PRIMECELL™, REALVIEW™, THUMB™, μVision™ of ARM Limited, UK. ANSI™ of American National Standards Institute. AUTOSAR™ of AUTOSAR development partnership. Bluetooth™ of Bluetooth SIG Inc. CAT-iq™ of DECT Forum. COLOSSUS™, FirstGPS™ of Trimble Navigation Ltd. EMV™ of EMVCo, LLC (Visa Holdings Inc.). EPCOS™ of Epcos AG. FLEXGO™ of Microsoft Corporation. HYPERTERMINAL™ of Hilgraeve Incorporated. MCS™ of Intel Corp. IEC™ of Commission Electrotechnique Internationale. IrDA™ of Infrared Data Association Corporation. ISO™ of INTERNATIONAL ORGANIZATION FOR STANDARDIZATION. MATLAB™ of MathWorks, Inc. MAXIM™ of Maxim Integrated Products, Inc. MICROTEC™, NUCLEUS™ of Mentor Graphics Corporation. MIPI™ of MIPI Alliance, Inc. MIPS™ of MIPS Technologies, Inc., USA. muRata™ of MURATA MANUFACTURING CO., MICROWAVE OFFICE™ (MWO) of Applied Wave Research Inc., OmniVision™ of OmniVision Technologies, Inc. Openwave™ of Openwave Systems Inc. RED HAT™ of Red Hat, Inc. RFMD™ of RF Micro Devices, Inc. SIRIUS™ of Sirius Satellite Radio Inc. SOLARIS™ of Sun Microsystems, Inc. SPANSION™ of Spansion LLC Ltd. Symbian™ of Symbian Software Limited. TAIYO YUDEN™ of Taiyo Yuden Co. TEAKLITE™ of CEVA, Inc. TEKTRONIX™ of Tektronix Inc. TOKO™ of TOKO KABUSHIKI KAISHA TA. UNIX™ of X/Open Company Limited. VERILOG™, PALLADIUM™ of Cadence Design Systems, Inc. VLYNQ™ of Texas Instruments Incorporated. VXWORKS™, WIND RIVER™ of WIND RIVER SYSTEMS, INC. ZETEX™ of Diodes Zetex Limited.

Last Trademarks Update 2014-07-17

www.infineon.com

Edition 20 March 2015

Published by

Infineon Technologies AG

81726 Munich, Germany

© 2015 Infineon Technologies AG.

All Rights Reserved.

Do you have a question about any aspect of this document?

Email: erratum@infineon.com

Document reference

Legal Disclaimer

THE INFORMATION GIVEN IN THIS APPLICATION NOTE (INCLUDING BUT NOT LIMITED TO CONTENTS OF REFERENCED WEBSITES) IS GIVEN AS A HINT FOR THE IMPLEMENTATION OF THE INFINEON TECHNOLOGIES COMPONENT ONLY AND SHALL NOT BE REGARDED AS ANY DESCRIPTION OR WARRANTY OF A CERTAIN FUNCTIONALITY, CONDITION OR QUALITY OF THE INFINEON TECHNOLOGIES COMPONENT. THE RECIPIENT OF THIS APPLICATION NOTE MUST VERIFY ANY FUNCTION DESCRIBED HEREIN IN THE REAL APPLICATION. INFINEON TECHNOLOGIES HEREBY DISCLAIMS ANY AND ALL WARRANTIES AND LIABILITIES OF ANY KIND (INCLUDING WITHOUT LIMITATION WARRANTIES OF NON-INFRINGEMENT OF INTELLECTUAL PROPERTY RIGHTS OF ANY THIRD PARTY) WITH RESPECT TO ANY AND ALL INFORMATION GIVEN IN THIS APPLICATION NOTE.

Information

For further information on technology, delivery terms and conditions and prices, please contact the nearest Infineon Technologies Office (www.infineon.com).

Warnings

Due to technical requirements, components may contain dangerous substances. For information on the types in question, please contact the nearest Infineon Technologies Office. Infineon Technologies components may be used in life-support devices or systems only with the express written approval of Infineon Technologies, if a failure of such components can reasonably be expected to cause the failure of that life-support device or system or to affect the safety or effectiveness of that device or system. Life support devices or systems are intended to be implanted in the human body or to support and/or maintain and sustain and/or protect human life. If they fail, it is reasonable to assume that the health of the user or other persons may be endangered.

Компания «Life Electronics» занимается поставками электронных компонентов импортного и отечественного производства от производителей и со складов крупных дистрибьюторов Европы, Америки и Азии.

С конца 2013 года компания активно расширяет линейку поставок компонентов по направлению коаксиальный кабель, кварцевые генераторы и конденсаторы (керамические, пленочные, электролитические), за счёт заключения дистрибьюторских договоров

Мы предлагаем:

- Конкурентоспособные цены и скидки постоянным клиентам.
- Специальные условия для постоянных клиентов.
- Подбор аналогов.
- Поставку компонентов в любых объемах, удовлетворяющих вашим потребностям.
- Приемлемые сроки поставки, возможна ускоренная поставка.
- Доставку товара в любую точку России и стран СНГ.
- Комплексную поставку.
- Работу по проектам и поставку образцов.
- Формирование склада под заказчика.
- Сертификаты соответствия на поставляемую продукцию (по желанию клиента).
- Тестирование поставляемой продукции.
- Поставку компонентов, требующих военную и космическую приемку.
- Входной контроль качества.
- Наличие сертификата ISO.

В составе нашей компании организован Конструкторский отдел, призванный помогать разработчикам, и инженерам.

Конструкторский отдел помогает осуществить:

- Регистрацию проекта у производителя компонентов.
- Техническую поддержку проекта.
- Защиту от снятия компонента с производства.
- Оценку стоимости проекта по компонентам.
- Изготовление тестовой платы монтаж и пусконаладочные работы.



Тел: +7 (812) 336 43 04 (многоканальный)

Email: org@lifeelectronics.ru