

# 24V DRIVEN RECEIPT, TICKET PRINTER

## 3" KIOSK PRINTER UNIT

### FTP-639USL100-R Series

#### ■ OVERVIEW

The FTP-639USL Series is 24V driven receipt printer unit with cutter for 3 inch wide paper. The unit has our high-speed FTP-639MCL mechanism, cutter and control board, with an integrated paper feed and built-in paper guide section.

The receipt printer unit is most suitable for applications such as Kiosk, ATM, receipt, label, and ticket issuing printers for various other equipment.

#### ■ FEATURES

- External presenter option
- Medium duty unit (mounting is easy)
- Ultra high speed printer (125/200mm / sec.)
- Auto cutter included
- Paper near end-detection function
- Up to 6 inch paper roll diameter
- Rear paper auto loading
- Paper jam detection
- Prints 2-D barcodes

#### ■ DESIGNATION

	Item	Part Number	Comment
Printer module interface	USB (ver 2.0)	FTP-639USL101*	without presenter
	Serial (RS-232C) / USB	FTP-639USL102*	
	USB (ver 2.0)	FTP-639USL201	with presenter
	Serial (RS-232C) / USB	FTP-639USL202	
Cables	USB interface	FTP-629Y301	
	Serial interface	FTP-629Y302	
	Power for logic, head, motor	FTP-629Y603	

\*: Interface board is FTP-629DSL350 series



FTP-639USL100 - horizontal



FTP-639USL100 - vertical

# FTP-639USL100-R Series

## ■ SPECIFICATIONS

Item		Specifications
Part number		FTP-639USL101/102/201/202
Printing method		Thermal-sensitive line dot method
Dot structure		576 dots/line
Dot pitch (Horizontal)		0.125 mm (8 dots/mm)—Dot density
Dot pitch (Vertical)		0.125 mm (8 dots/mm)—Line feed pitch
Effective printing area		72 mm
Paper width		80 <sup>+0</sup> <sub>-1</sub> mm
Paper thickness		60 to 100 μm
Paper print length		50 to 250mm
Cutting type		Full or partial
Number of columns		48 columns/line (12×24 dot font)
Maximum printing speed		1600 dotlines/s (200 mm/s)
Page mode	Middle speed mode	80mm/sec. without automatic division
	High speed mode	125 mm/sec.without automatic division
	Ultra high speed mode	200 mm/sec.without automatic division
Character types		Alphanumeric KANA: 159, Registered: 94, International: 195, OCR: 103 JIS KANJI (FTP-629DSL400): approximately 6800
Character composition, dimensions (H×W), Number of characters		24 × 12 dots, (3.0 × 1.5 mm), 48 columns 24 × 24 dots, (3.0 × 3.0 mm), 24 columns 16 × 8 dots, (2.0 × 1.0 mm), 72 columns 16 × 16 dots, (2.0 × 2.0 mm), 36 columns OCR I: 24 × 40, 24 columns OCR III: 24 × 48, 24 columns OCR IV: 36×60, 16 columns Expanded: 24×48, 24 columns
Interface		Serial (RS232C), USB
Power supply	For head	24VDC ± 5%, Voltage Current : average*1 ( ) : Peak 12.5% printing ratio 1.0 (2.0) A (at 200 mm/s printing speed, 1 division) 0.7 (1.0) A (at 125 mm/s printing speed, 2 divisions) 0.6 (1.0) A (at 80 mm/s printing speed, 2 divisions) 0.6 (2.0) A (at 80mm/s printing speed, automatic division)
	For print motor	24VDC ± 5%, 1.1 A maximum, 0.9A average
	For cutter	24VDC ± 5%, 1.3 A maximum
	For logic	5VDC ± 5%, 0.2 A maximum (converted from 24V)

(Continued)

# FTP-639USL100-R Series

(Continued)

Item		Specifications
Dimensions		120.0(W) × 100.0(D) × 80.0(H) mm
Weight (mechanism, cutter, board, frame)		Approximately 760g without arm, 990g with arm
Expected life	Mechanism	Pulse durability : 100 million pulse/dot (using Fujitsu's standard driving method) Wear resistance: 100 km (at 12.5% printing ratio)
	Cutter	1,000,000 cuts
	Platen	5,000 cycles
Environmental conditions	Operating temperature	-20°C to +60°C
	Operating humidity	10 to 85% RH (no condensation)
	Storage temperature	-25°C to +65°C (excluding paper)
	Storage humidity	5 to 90% RH (no condensation)
Detection	Head temperature	By thermistor (applied energy control, abnormal temperature detection)
	Paper out/Mark detect	By photointerrupter
	Platen open	By microswitch
	Near end paper	By mechanical switch
Recommended thermal sensitive paper		For rear insertion use (80 mm width) : FTP-030P0701/P0102 Recommended papers · Oji Paper : PD150R,PD160R-N,PD170R · NIPPON Paper : TF50KS-E,TF60KS-E,TF50KS-E4 · MITSUBISHI Paper Mills : P220VBB-1,AFP-235
Paper diameter	Standard	83mm
	Extended	150mm

\*1: 24VDC, minimum head resistance.

## ■ FUNCTIONS

Item	Item
1. Test print function	9. Internal RAM abnormality detection
2. Paper feed	10. Cutter abnormality detection
3. Paper out detection	11. Mark detection
4. Paper near end detection	12. MCU operation abnormality detection
5. Platen open detection	13. Motor power saving
6. Thermal head temperature abnormality detection	14. Power supply disconnection protection
7. Motor temperature detection	15. Motor protection
8. Voltage abnormality detection	16. Thermal head protection

## ■ INTERFACE , COMMAND, OPTIONS

Please refer to the FTP-629DSL350 series. Interface command options, please see FTP-609 datasheet.

## EXTERNAL DIMENSION SPECIFICATIONS

### 1. External Dimension Chart of the Control Board

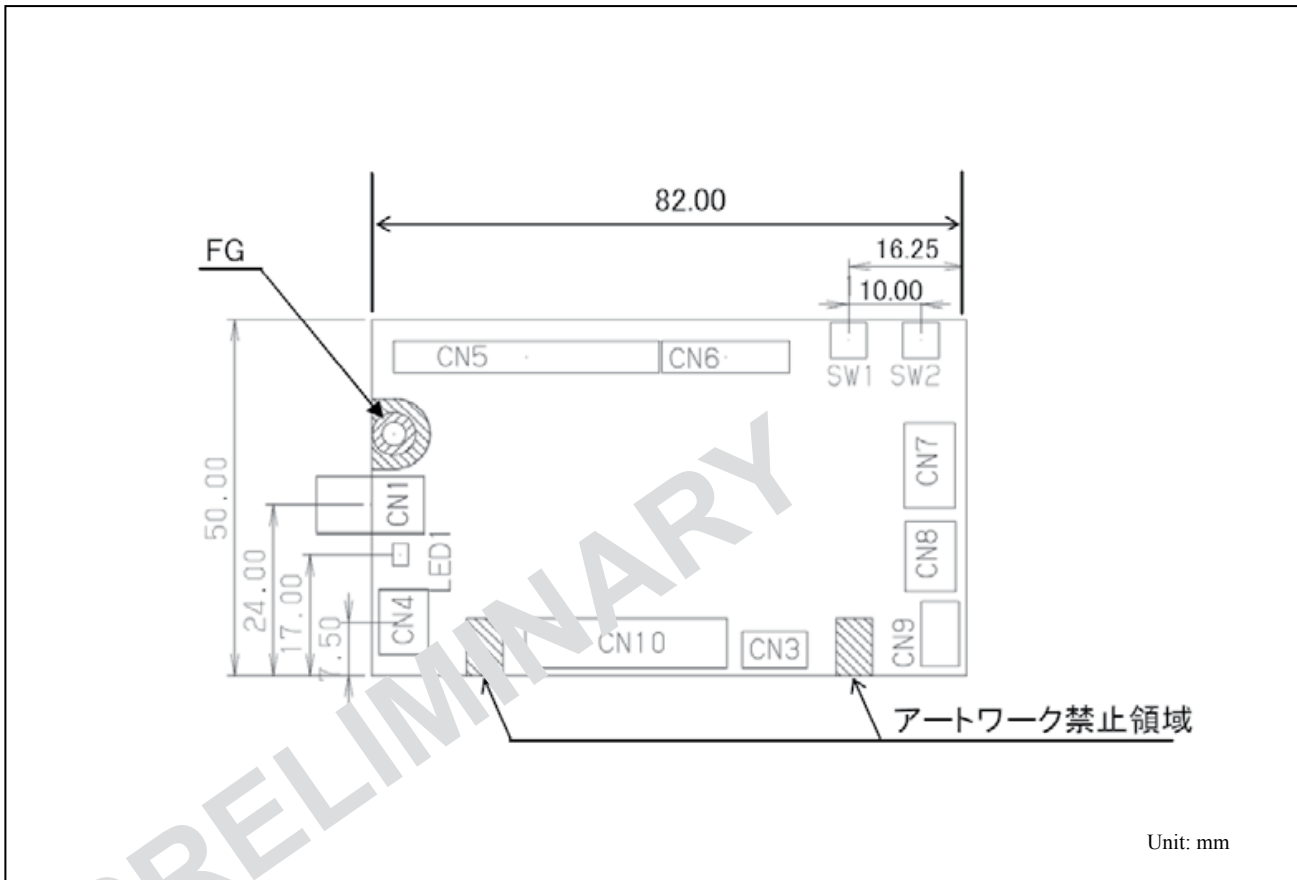

### 2. Connector Types of Control Board

No.	Name	Function	Remarks
CN1	Power connector	Connect +24V power supply	-
CN2	RS-232 connector	Connect RS-232 interface	depends on models
CN3	Operation panel connector	Connect to operation panel	-
CN4	USB interface connector	Connect USB interface	depends on models
CN5	Thermal head connector	Connect thermal head	-
CN6	Paper feed motor	Connect paper feed motor	-
CN7	Cutter connector	Connect cutter motor	-
CN8	Near end connector	Connect near end switch or sensor	-
CN9	External sensor connector	Connect external sensor	optional

# FTP-639USL100-R Series

## ■ DIMENSIONS

### Modular printer without presenter and standard paper roll

(1) Paper Diameter: 83mm

Horizontal installation

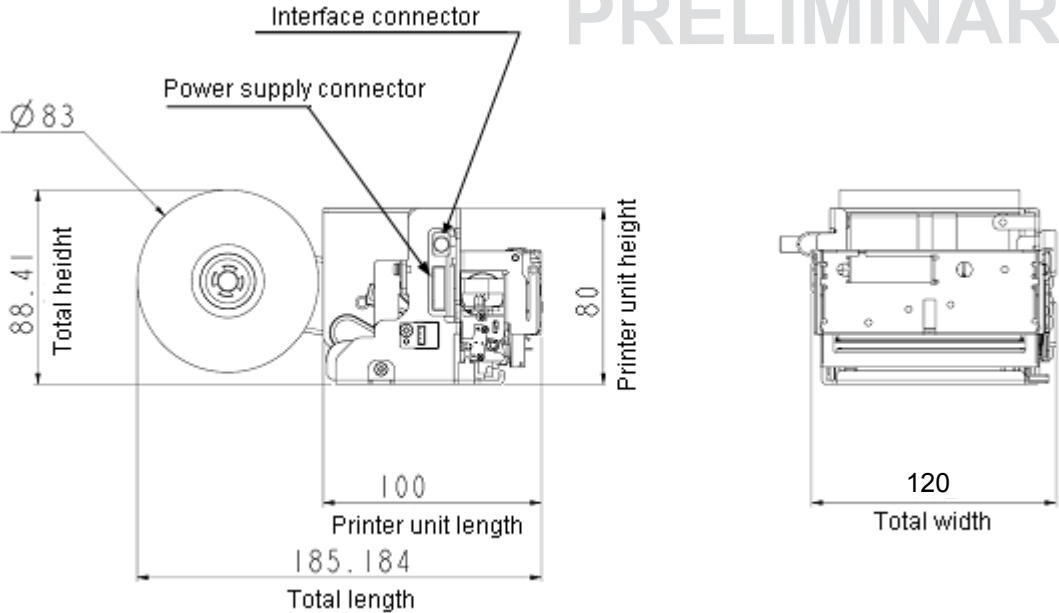

Lower installation

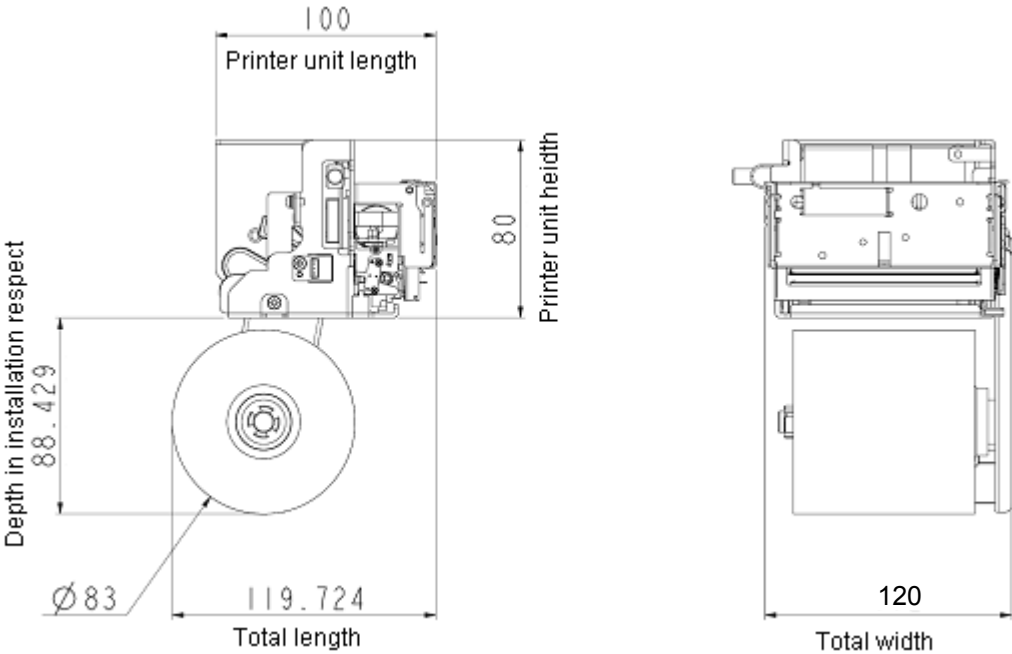

## ■ DIMENSIONS

### Modular printer without presenter and large paper roll

(1) Paper Diameter: 150mm  
Horizontal installation

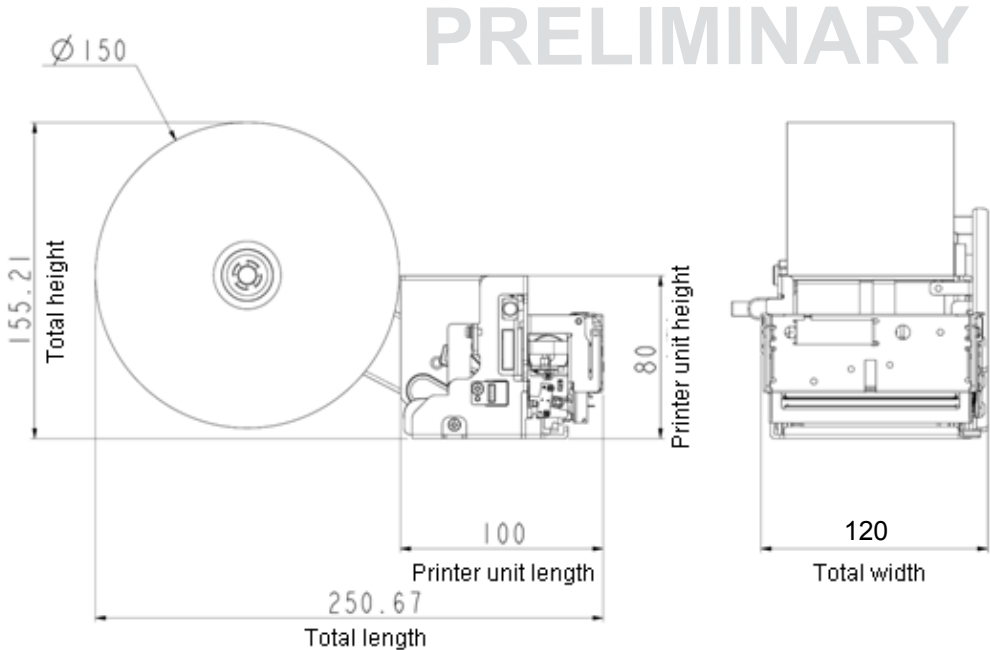

Lower installation

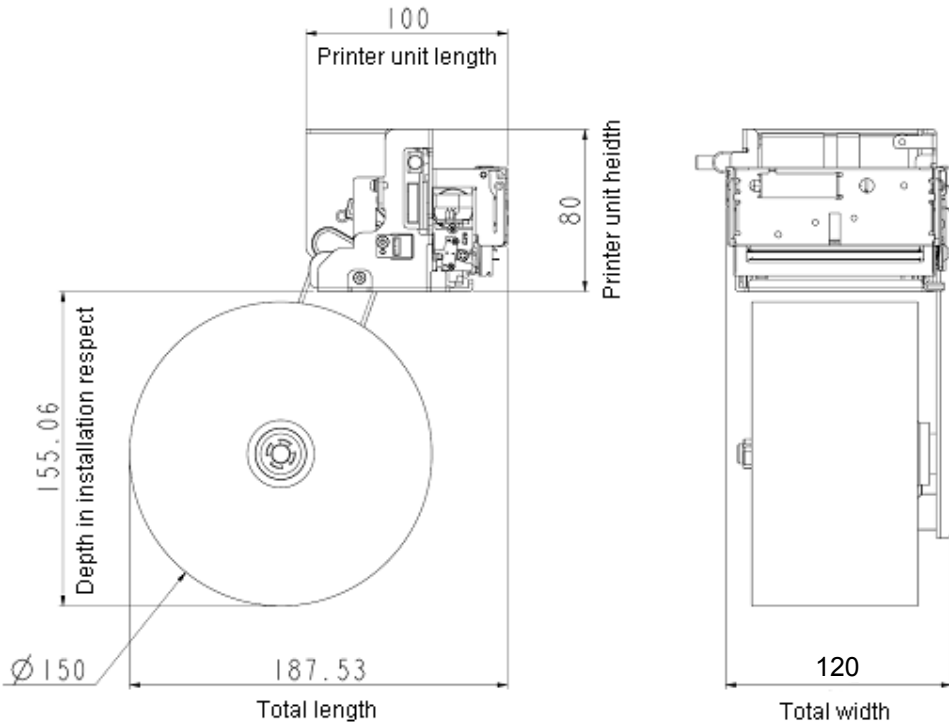

■ DIMENSIONS

Modular printer with presenter and large paper roll

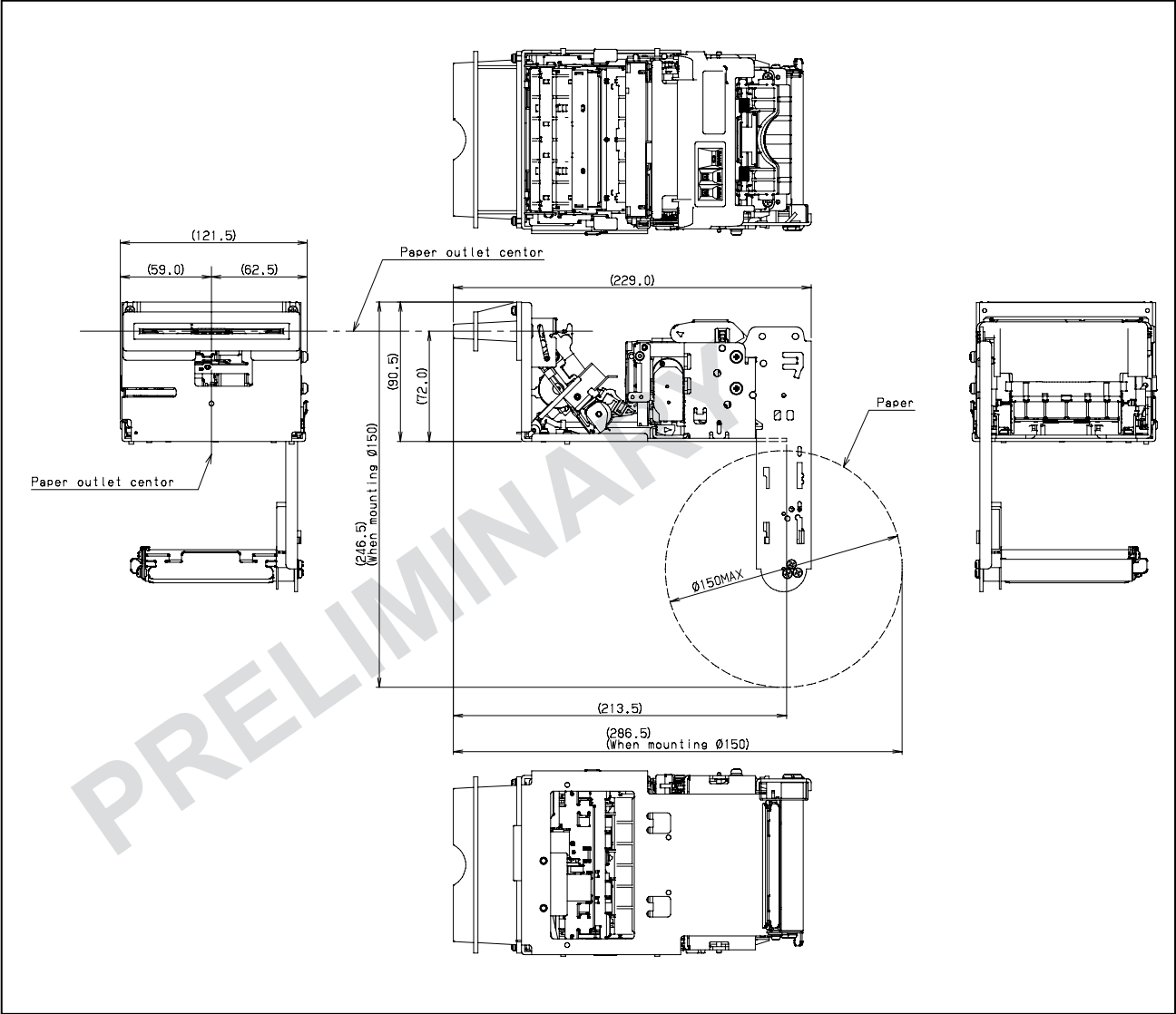

# FTP-639USL100-R Series

## ■ COMMANDS

Command	Contents
HT	Moves print position to the next tab.
LF	Line feed.
FF	Feeds forms (new page).
ESC EM+n	Setting the amount of the feeding at automatic paper feed.
ECS RS	Sets reverse printing.
ESC US	Resets reverse printing.
ESC SP+n	Character spacing setting.
ESC ! + n	Sets print mode.
ESC % + n	External registration character specification/cancellation.
ESC & +y+c1+c2+x+d1to dn	External registration character definition.
ESC *+m+n1+n2+d1+dN	Sets bit image mode.
ESC - +n	Undeline setting.
ESC 2	Sets 1/6 inch line feed length.
ESC 3+n	Sets the line feed length.
ESC ? + n	External registration character deletion.
ESC @	Printer initialization.
ESC A+n	Sets the space between the line.
ESC C+n	Sets the page length by character line.
ESC D+d1+dN +NUL	Sets the tab position.
ESC J+n	Feeds paper in forward direction and prints.
ESC K+n	Reverse paper feed.
ESC R+n	Selects international character.
ESC V+n	Right Rotation 90° specification / cancellation
ESC X+m+n	Setting the turning time of the motor excitation.
ESC c+1+n	Sets internal processing.
ESC c+5+n	Panel switch enable/disable setting.
ESC d+n	Printing and n-line feeding.
ESC e+n	Prints and reverse feeds n-lines.
ECS s+n	Sets printing speed.
ECS t+n	Character code table selection.
ESC {+n	Sets/resets upside down printing.



# FTP-639USL100-R Series

Commands continued

Command	Contents
ESC DEL+n	
FS !+n	Kanji printing mode collective specification.
FS &	Kanji printing mode specification.
FS - + n	Kanji underline specification/cancellation.
FS *+ m+n1+n2+d1 to dn	High speed collective image printing specified.
FS .	Kanji printing mode cancellation.
FS 2+c1+c2+d1 to dn	External character definition.
FS 9+n	Sets the detection functions.
FS C+n	Kanji code system selection.
FS E+n	Correction of impressed energy.
FS S+n+n1+n2	Kanji spacing setting.
FS W+n	Kanji double height and width printing specification/cancellation.
FS r+n <sup>*1</sup>	Parameter transmission.
GS ! + n	Character size specification.
GS & +m + x + y1 + y2 + d1 to dn	Registered bit image definition.
GS' + m + n	Registered bit image printing..
GS (+E+L1+L2+n+d,~dq	RS-232C communication setting* <sup>1</sup>
GS <	Line feeds to the next mark.
GS A+m+n	Sets the line feed length after mark detection.
GS E+n	Sets print quality.
GS L+n1+n2	Left margin position setting.
GS V+m+n	
GS W + n1 + n2	Printing area width setting.
GS a+n	Automatic status transmission setting* <sup>1</sup>
GS e+n+m	Sets bar code width.
GS h+n	Sets bar code height.
GS k+m+n+ d1 to dn	Bar code printing.
GS w+n	Sets bar code length.

\*<sup>1</sup>: These commands are valid with FTP-629DSL350 series serial interface.

# FTP-639USL100-R Series

## ■ OPTIONS

### 1. Cables

Name		Part Number	Cable length
Interface cable (board to mechanism)	USB	FTP-629Y301	500mm (19.7 inch)
	RS-232C	FTP-629Y302	500mm (19.7 inch)
Power supply cable	Logic, head, motor	FTP-629Y603	300mm (11. 8inch)

### 2. Driver LSI of Control Board

Name	Part Number	Quantity / Tray	Remarks
MCU	FTP-629CU350	84	On-board Flash and SRAM

## Fujitsu Components International Headquarter Offices

<b>Japan</b> Fujitsu Component Limited Gotanda-Chuo Building 3-5, Higashigotanda 2-chome, Shinagawa-ku Tokyo 141 8630, Japan Tel: (81-3) 5449-7010 Fax: (81-3) 5449-2626 Email: <a href="mailto:promothq@fcl.fujitsu.com">promothq@fcl.fujitsu.com</a> Web: <a href="http://www.fcl.fujitsu.com">www.fcl.fujitsu.com</a>	<b>Europe</b> Fujitsu Components Europe B.V. Diamantlaan 25 2132 WV Hoofddorp Netherlands Tel: (31-23) 5560910 Fax: (31-23) 5560950 Email: <a href="mailto:info@fceu.fujitsu.com">info@fceu.fujitsu.com</a> Web: <a href="http://emea.fujitsu.com/components/">emea.fujitsu.com/components/</a>
<b>North and South America</b> Fujitsu Components America, Inc. 250 E. Caribbean Drive Sunnyvale, CA 94089 U.S.A. Tel: (1-408) 745-4900 Fax: (1-408) 745-4970 Email: <a href="mailto:components@us.fujitsu.com">components@us.fujitsu.com</a> Web: <a href="http://us.fujitsu.com/components/">http://us.fujitsu.com/components/</a>	<b>Asia Pacific</b> Fujitsu Components Asia Ltd. 102E Pasir Panjang Road #01-01 Citilink Warehouse Complex Singapore 118529 Tel: (65) 6375-8560 Fax: (65) 6273-3021 Email: <a href="mailto:fcal@fcal.fujitsu.com">fcal@fcal.fujitsu.com</a> Web: <a href="http://www.fujitsu.com/sg/services/micro/components/">http://www.fujitsu.com/sg/services/micro/components/</a>

©2012 Fujitsu Components America, Inc. All rights reserved. All trademarks or registered trademarks are the property of their respective owners.

Fujitsu Components America or its affiliates do not warrant that the content of datasheet is error free. In a continuing effort to improve our products Fujitsu Components America, Inc. or its affiliates reserve the right to change specifications/datasheets without prior notice.  
Rev. October 16, 2012.

Компания «Life Electronics» занимается поставками электронных компонентов импортного и отечественного производства от производителей и со складов крупных дистрибьюторов Европы, Америки и Азии.

С конца 2013 года компания активно расширяет линейку поставок компонентов по направлению коаксиальный кабель, кварцевые генераторы и конденсаторы (керамические, пленочные, электролитические), за счёт заключения дистрибьюторских договоров

Мы предлагаем:

- Конкурентоспособные цены и скидки постоянным клиентам.
- Специальные условия для постоянных клиентов.
- Подбор аналогов.
- Поставку компонентов в любых объемах, удовлетворяющих вашим потребностям.
- Приемлемые сроки поставки, возможна ускоренная поставка.
- Доставку товара в любую точку России и стран СНГ.
- Комплексную поставку.
- Работу по проектам и поставку образцов.
- Формирование склада под заказчика.
- Сертификаты соответствия на поставляемую продукцию (по желанию клиента).
- Тестирование поставляемой продукции.
- Поставку компонентов, требующих военную и космическую приемку.
- Входной контроль качества.
- Наличие сертификата ISO.

В составе нашей компании организован Конструкторский отдел, призванный помогать разработчикам, и инженерам.

Конструкторский отдел помогает осуществить:

- Регистрацию проекта у производителя компонентов.
- Техническую поддержку проекта.
- Защиту от снятия компонента с производства.
- Оценку стоимости проекта по компонентам.
- Изготовление тестовой платы монтаж и пусконаладочные работы.



Тел: +7 (812) 336 43 04 (многоканальный)

Email: [org@lifeelectronics.ru](mailto:org@lifeelectronics.ru)