

Constant Current LED Driver with PWM Dimming Control

■ GENERAL DESCRIPTION

The NJW4615A is a constant current LED driver with PWM dimming control. Driving roads up to 100mA, the output current level can be adjusted via an external resistor.

Because the withstand voltage of the LED pin is 35V, it can series-connect the LED depending on forward voltage of the LED.

The LED brightness control can be regulated via PWM duty cycle. It suitable for back light, light source and so on.

■ PACKAGE OUTLINE

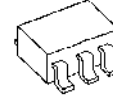

NJW4615AF1
(SOT-23-6-1)

■ FEATURES

- Supply Voltage Range 2.5V to 35V
- Output Voltage $V_{LED}=35V$ max.
- Output Current $I_{LED}=5mA$ to 100mA
- Output Current Accuracy $\pm 1.2\%$
- To 10 of White LED can be operated. (at LED $V_f=3.4V$)
- Quiescent Current 370 μA max.
- PWM Dimming Control
- ON/OFF Control
- Over Current Protection
- Thermal Shutdown Protection
- LED Short Protection
- Package SOT-23-6-1

■ BLOCK DIAGRAM

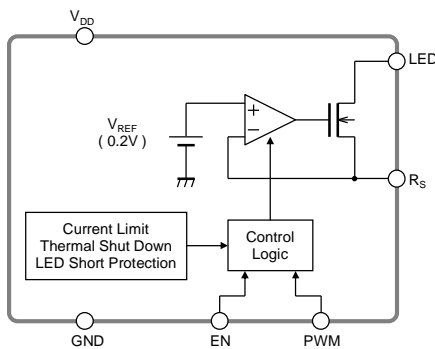

■ PIN CONFIGURATION

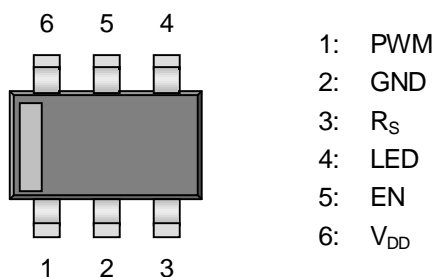

NJW4615A

■ ABSOLUTE MAXIMUM RATINGS

(Ta=25°C)

PARAMETERS	SYMBOL	RATINGS	UNIT
Supply Voltage	V _{DD}	-0.3 to +40	V
Output voltage	V _{LED}	-0.3 to +40	V
EN Pin Voltage	V _{EN}	-0.3 to +40	V
PWM Pin Voltage	V _{PWM}	-0.3 to +6	V
Power Dissipation	P _D	510 (*1) 710 (*2)	mW
Junction Temperature Range	T _j	-40 to +150	°C
Operating Temperature Range	T _{opr}	-40 to +125	°C
Storage Temperature Range	T _{stg}	-50 to +150	°C

(*1): Mounted on glass epoxy board. (76.2x114.3x1.6mm: based on EIA/JEDEC standard, 2Layers)

(*2): Mounted on glass epoxy board. (76.2x114.3x1.6mm: based on EIA/JEDEC standard, 4Layers),

Internal Cu area: 74.2x74.2mm

■ RECOMMENDED OPERATING CONDITIONS

(Ta=25°C)

PARAMETERS	SYMBOL	CONDITIONS	MIN	TYP	MAX	Unit
Supply Voltage	V _{DD}		2.5	-	35	V
Output Current	I _{LED}		5	-	100	mA
Output Voltage	V _{LED}		-	-	35	V

■ ELECTRICAL CHARACTERISTICS

(Unless otherwise noted, V_{DD}=V_{EN}=12V, V_{LED}=1V, R_S=10Ω, V_{PWM}=OPEN, Ta=25°C)

PARAMETERS	SYMBOL	CONDITIONS	MIN	TYP	MAX	Unit
Quiescent Current	I _{DD}		-	260	370	μA
Quiescent Current at OFF State	I _{DD_OFF}	V _{EN} =GND	-	-	0.1	μA
Output Current Accuracy	ΔI _{LED}		-1.2	-	+1.2	%
Output Pin Leak Current 1	I _{LEAK1}	V _{EN} =GND, V _{DD} =35V, V _{LED} =35V	-	-	0.1	μA
Output Pin Leak Current 2	I _{LEAK2}	V _{PWM} =GND, V _{DD} =35V, V _{LED} =35V	-	-	0.1	μA
EN Pin ON Voltage	V _{EN_ON}	I _{LED} =OFF→ON	1.6	-	V _{DD}	V
EN Pin OFF Voltage	V _{EN_OFF}	I _{LED} =ON→OFF	0	-	0.3	V
PWM Pin ON Voltage 1	V _{PWM_ON1}	V _{DD} <5V, I _{LED} =OFF→ON	0.7V _{DD}	-	V _{DD}	V
PWM Pin OFF Voltage 1	V _{PWM_OFF1}	V _{DD} <5V, I _{LED} =ON→OFF	0	-	0.3V _{DD}	V
PWM Pin ON Voltage 2	V _{PWM_ON2}	V _{DD} ≥5V, I _{LED} =OFF→ON	3.5	-	5.5	V
PWM Pin OFF Voltage 2	V _{PWM_OFF2}	V _{DD} ≥5V, I _{LED} =ON→OFF	0	-	1.5	V
EN Pin Input Current	I _{EN}	V _{EN} =12V	-	7	-	μA
PWM Pin Pull Up Resistance	R _{PWM}		-	1	-	MΩ
R _S Pin Output Current	I _{OUT_RS}	LED=OPEN	-	2.3	-	μA
PWM Pin ON Delay Time	t _{PWM_ON}	V _{PWM} =L→H, I _{LED} =OFF→ON	-	3	-	μs
PWM Pin OFF Delay Time	t _{PWM_OFF}	V _{PWM} =H→L, I _{LED} =ON→OFF	-	1	-	μs
LED Short Protection Detect Voltage	V _{LED_SHORT}		17	20	23	V
Maximum Output Current	I _{LED_MAX}	R _S =0Ω	100	170	-	mA

■ TYPICAL APPLICATION

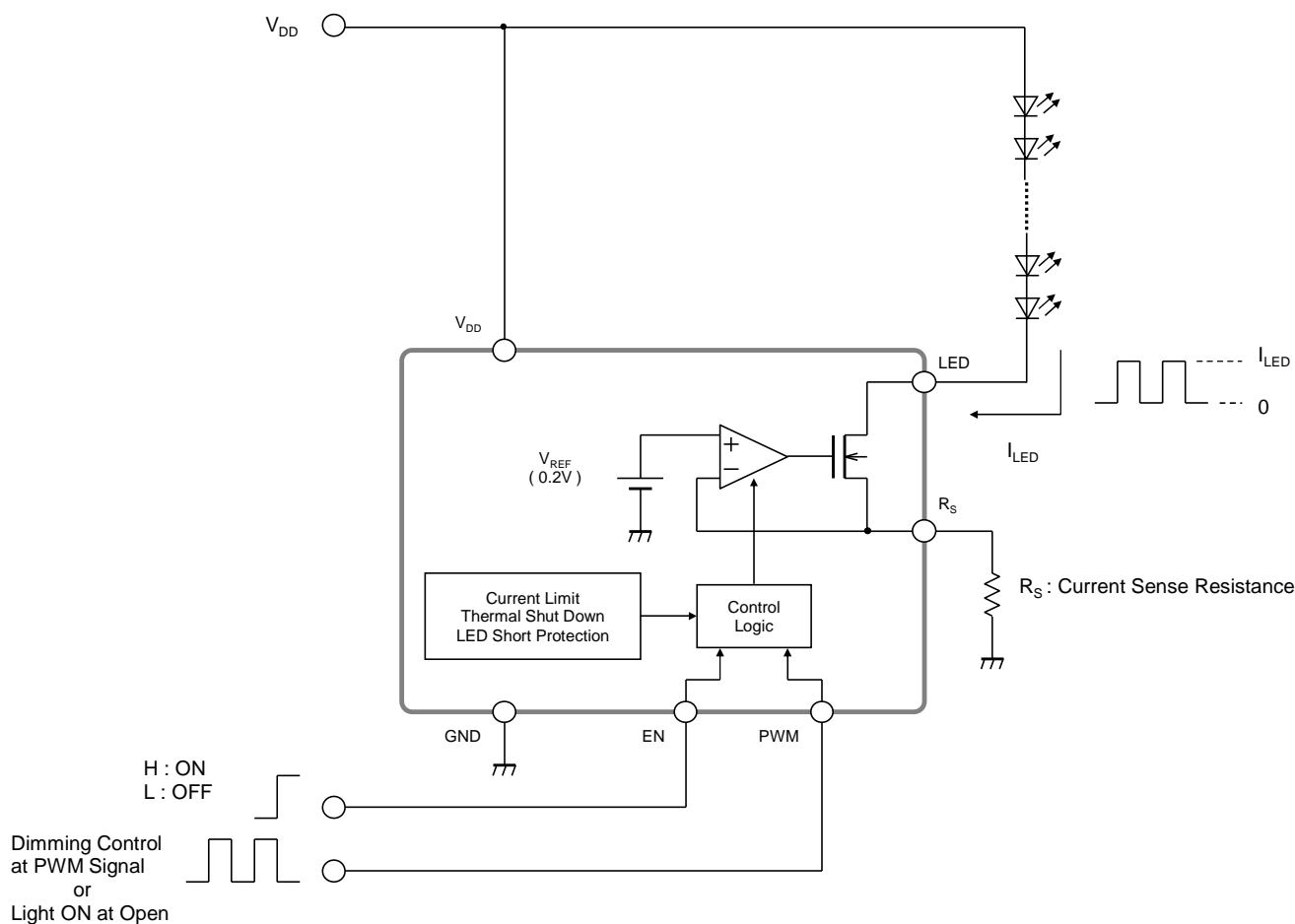

The R_S Resistance Setting formula: $R_S(\Omega) = \frac{0.2(V)}{I_{LED}(A)}$

■ PIN DESCRIPTIONS

Pin No.	Pin Name	I/O	Function
1	PWM	I	PWM Signal input pin for Dimming Control. Not use Dimming Control, This pin is open.
2	GND	-	Ground
3	R_S	O	I _{LED} Setting Resistor Connect Pin. The LED current can be set connecting resistance (R_S) between R_S pin and GND pin. $R_S[\Omega] = 0.2[V] / I_{LED}[A]$
4	LED	O	Constant Current Circuit Output Pin Connect Cathode Pin of LED.
5	EN	I	Standby Control Pin Normal Operation at the time of High Level. Standby Mode at the time of Low Level.
6	V_{DD}	I	Power Supply

MEMO

[CAUTION]

The specifications on this databook are only given for information, without any guarantee as regards either mistakes or omissions. The application circuits in this databook are described only to show representative usages of the product and not intended for the guarantee or permission of any right including the industrial rights.

Mouser Electronics

Authorized Distributor

Click to View Pricing, Inventory, Delivery & Lifecycle Information:

[NJR:](#)

[NJW4615F1-TE2](#) [NJW4615AF1-TE1](#)

Компания «Life Electronics» занимается поставками электронных компонентов импортного и отечественного производства от производителей и со складов крупных дистрибьюторов Европы, Америки и Азии.

С конца 2013 года компания активно расширяет линейку поставок компонентов по направлению коаксиальный кабель, кварцевые генераторы и конденсаторы (керамические, пленочные, электролитические), за счёт заключения дистрибьюторских договоров

Мы предлагаем:

- Конкурентоспособные цены и скидки постоянным клиентам.
- Специальные условия для постоянных клиентов.
- Подбор аналогов.
- Поставку компонентов в любых объемах, удовлетворяющих вашим потребностям.
- Приемлемые сроки поставки, возможна ускоренная поставка.
- Доставку товара в любую точку России и стран СНГ.
- Комплексную поставку.
- Работу по проектам и поставку образцов.
- Формирование склада под заказчика.
- Сертификаты соответствия на поставляемую продукцию (по желанию клиента).
- Тестирование поставляемой продукции.
- Поставку компонентов, требующих военную и космическую приемку.
- Входной контроль качества.
- Наличие сертификата ISO.

В составе нашей компании организован Конструкторский отдел, призванный помогать разработчикам, и инженерам.

Конструкторский отдел помогает осуществить:

- Регистрацию проекта у производителя компонентов.
- Техническую поддержку проекта.
- Защиту от снятия компонента с производства.
- Оценку стоимости проекта по компонентам.
- Изготовление тестовой платы монтаж и пусконаладочные работы.



Тел: +7 (812) 336 43 04 (многоканальный)

Email: org@lifeelectronics.ru