

DC Brushless FAN Motor Drivers

Three-phase Full-wave Fan Motor Driver



BD6346FV

General Description

BD6346FV is a three phase, sensorless motor 1chip driver with integrated power DMOS MOSFETs. Its feature is sensor-less drive which doesn't require a hall device as a location detection sensor. Furthermore, introducing a PWM soft switched driving mechanism achieves silent operations and low vibrations.

Features

- Integrated Power DMOS FET driver
- Sensorless PWM soft switched drive
- Lock protection and automatic restart
- DC voltage/direct PWM input ,speed control
- Current limit
- Soft-Start function
- Quick-Start function
- Rotating speed pulse signal(FG)output
- UVLO

Package(s)

SSOP-B20

W (Typ.) x D (Typ.) x H (Max.)

6.50mm x 6.40mm x 1.45mm



Applications

- Refrigerator, Sever, Desktop, cooling Fan for general consumer equipment

Absolute maximum ratings

Parameter	Symbol	Limit	Unit
Supply voltage	V_{CC}	20	V
Power dissipation	P_d	1200* ¹	mW
Operating temperature	T_{opr}	-40 to +100	
Storage temperature	T_{stg}	-55 to +150	
Output voltage	V_{omax}	20	V
Output Current	I_{omax}	1.2* ²	A
FG signal output voltage	V_{FG}	20	V
FG signal output current	I_{FG}	10	mA
REF current ability	I_{REF}	8	mA
Input voltage 1 (COM)	V_{in1}	20	V
Input voltage2 (CONT, MIN, SS, OSC, TOSC, SEL)	V_{in2}	6.5	V
Junction temperature	T_{jmax}	150	°C

*1 Reduce by 9.6mW/°C, over $T_a=25^{\circ}C$ (on 70.0mm×70.0mm×1.6mm glass epoxy board)

*2 This value is not exceed P_d and ASO

Recommended operating conditions

Parameter	Symbol	Limit	Unit
supply voltage range	V_{cc}	5.5 to 17.0	V
Input voltage (CONT)	V_{cont}	0 to V_{ref}	V
Input voltage (MIN)	V_{min}	V_{oscl} to V_{ref}	V
Input frequency (CONT, OSC=GND setting)	F_{cont}	20 to 50	kHz

Pin Configuration(s)

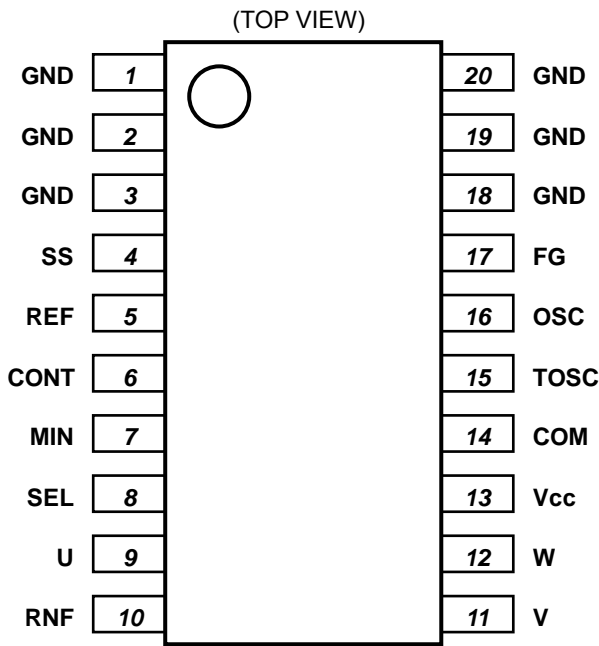

Fig. 1 Pin configuration

Pin description

P/No.	T/Name	Function
1	GND	GND terminal (signal GND)
2	GND	GND terminal (signal GND)
3	GND	GND terminal (signal GND)
4	SS	Soft-Start capacitor connecting terminal
5	REF	Reference voltage terminal
6	CONT	Output duty control terminal
7	MIN	Minimum rotating speed setting terminal
8	SEL	Output slope current select terminal
9	U	Motor output U terminal
10	RNF	Output current detecting terminal (Motor GND)
11	V	Motor output V terminal
12	W	Motor output W terminal
13	Vcc	Power Supply terminal
14	COM	Motor central tap terminal
15	TOSC	Oscillating capacitor connecting terminal for synchronous driving
16	OSC	Oscillating capacitor connecting terminal for output PWM operation
17	FG	Rotating speed pulse signal output terminal
18	GND	GND terminal (signal GND)
19	GND	GND terminal (signal GND)
20	GND	GND terminal (signal GND)

GND pin is shorted all GND pin (1-3, 18-20) on board

Block diagram

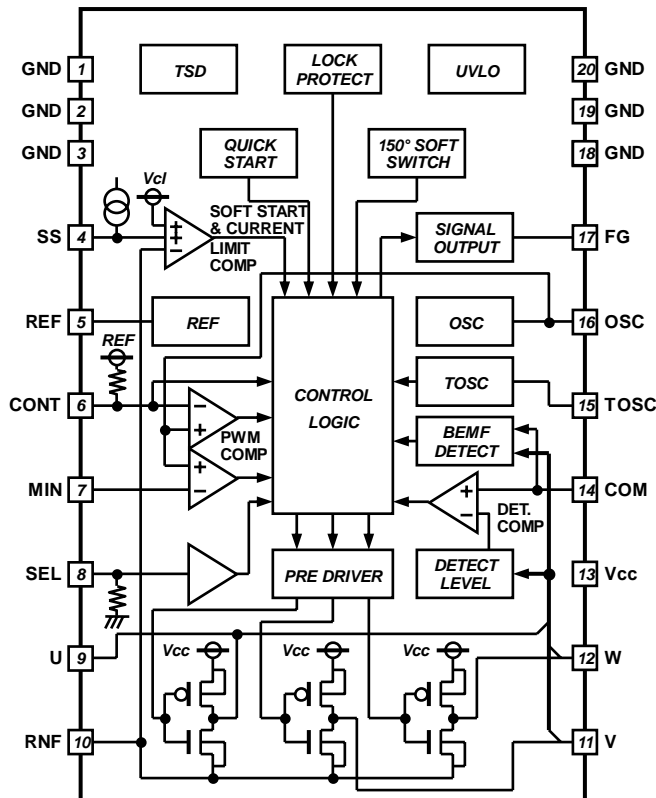

Fig. 2 Block diagram

Electrical characteristics(Unless otherwise specified Ta=25°C, Vcc=12V)

Parameter	Symbol	Limit			Unit Min.	Conditions Typ.	Ref. data
		Min.	Typ.	Max.			
Circuit current	Icc	3.6	6	8.4	mA		P.4
<REF>							
REF voltage	Vref	4.65	5.00	5.35	V	Iref=-2mA	P.4
<TOSC>							
TOSC high voltage	Vtosch	2.3	2.5	2.7	V		P.4
TOSC low voltage	Vtoscl	0.80	1.05	1.20	V		P.4
TOSC Charge current	Ictosc	-80	-60	-40	μA		P.5
TOSC Discharge current	Idtosc	40	60	80	μA		P.5
<CONT, MIN>							
CONT input high voltage	Vconth	2.8	-	-	V	Vosc=0V	-
CONT input low voltage	Vcontl	-	-	1.0	V	Vosc=0V	-
CONT input bias current	Icont	-	-	-1	μA		P.6
CONT input frequency	Fcont	20	-	50	kHz		-
MIN input bias current	Imin	-	-	-1	μA		P.6
<OSC>							
OSC High voltage	Vosch	2.3	2.5	2.7	V		P.6
OSC Low voltage	Voscl	0.80	1.05	1.20	V		P.6
OSC Charge current	Icosc	-40	-30	-20	μA		P.6
OSC Discharge current	Idosc	20	30	40	μA		P.6
<Current Limit>							
Current limit voltage	Vcl	200	250	300	mV		P.7
<Soft-Start>							
SS charge current	Icss	1.35	1.9	2.45	μA	Vss=0V	P.7
<FG>							
FG output Low voltage	Vfgl	-	0.3	0.4	V	I _{fg} =5mA	P.5
FG output leak current	I _{fgl}	-	-	10	μA	V _{fg} =20V	P.5
<Lock protection>							
Lock detect ON time	T _{on}	0.5	1	1.5	s	TOSC_CAP=1000pF	-
Lock detect OFF time	T _{off}	2.5	5	7.5	s		-
<Output>							
Output high voltage	V _{ohh}	-	0.15	0.20	V	I _o =-200mA, for VCC voltage	P.7
Output low voltage	V _{oll}	-	0.09	0.16	V	I _o =+200mA	P.8

About a current item, define the inflow current to IC as a positive notation, and the outflow current from IC as a negative notation.

Typical performance curves(Reference data)

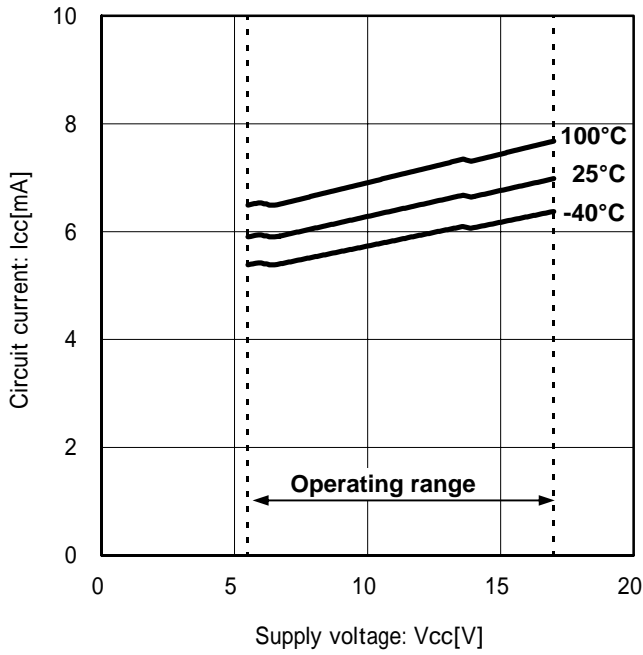

Fig. 3 Circuit current

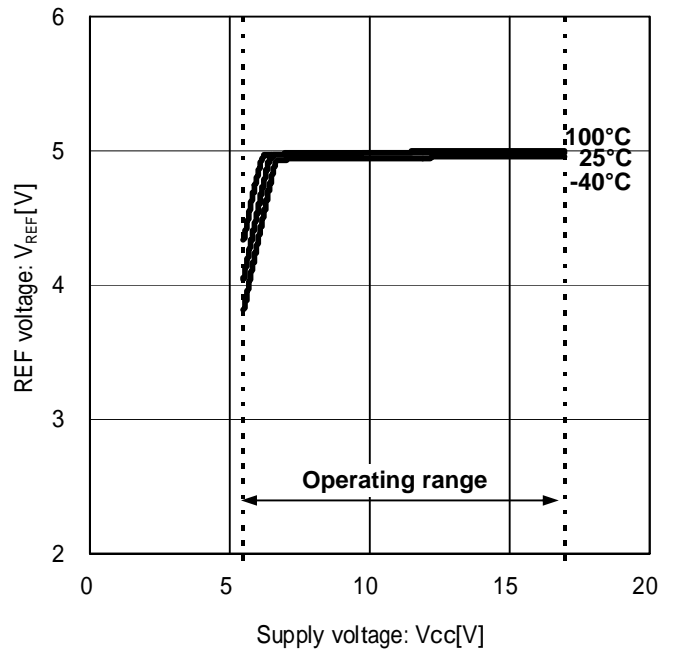

Fig. 4 REF voltage

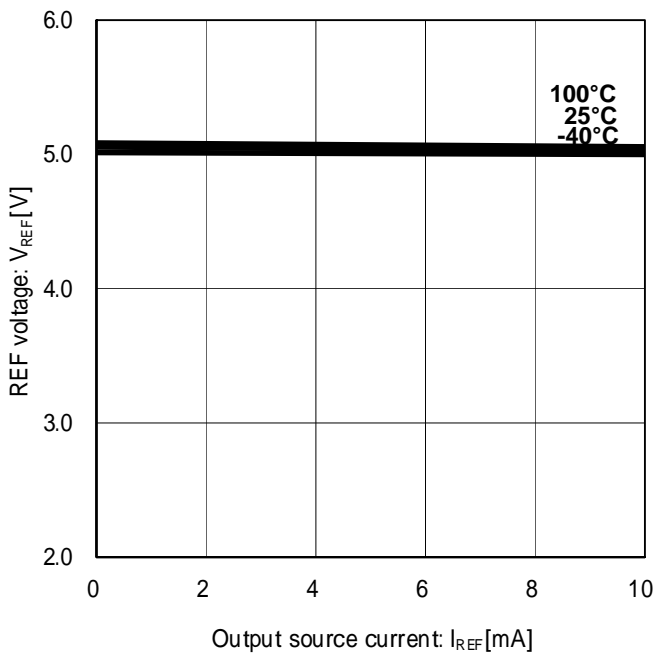

Fig. 5 REF voltage current ability (Vcc=12V)

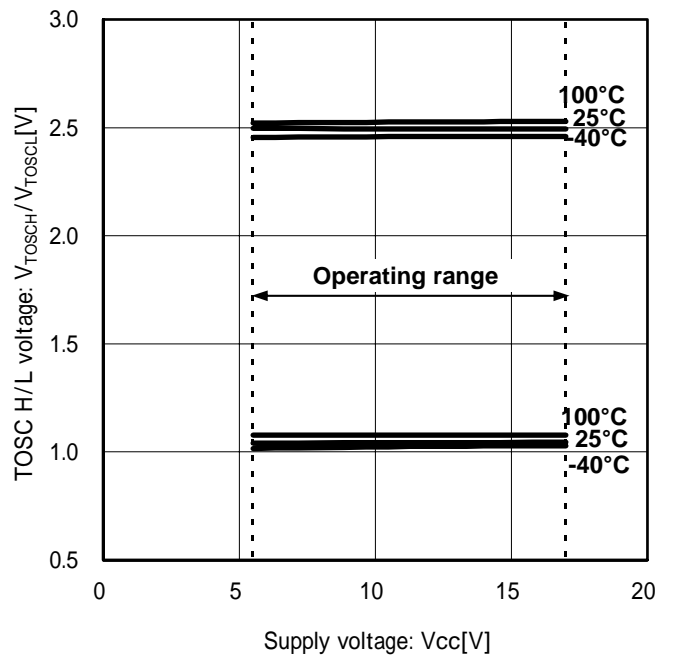

Fig. 6 TOSC High/Low voltage

Typical performance curves(Reference data)

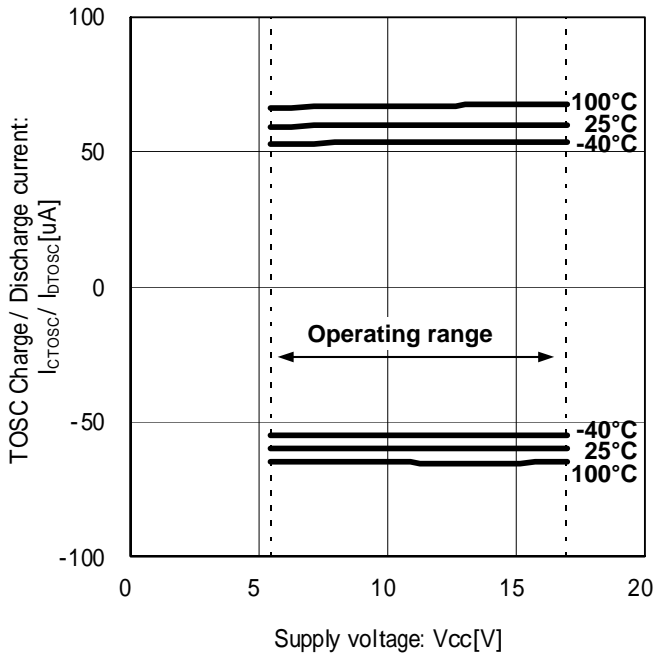

Fig. 7 TOSC charge/discharge current

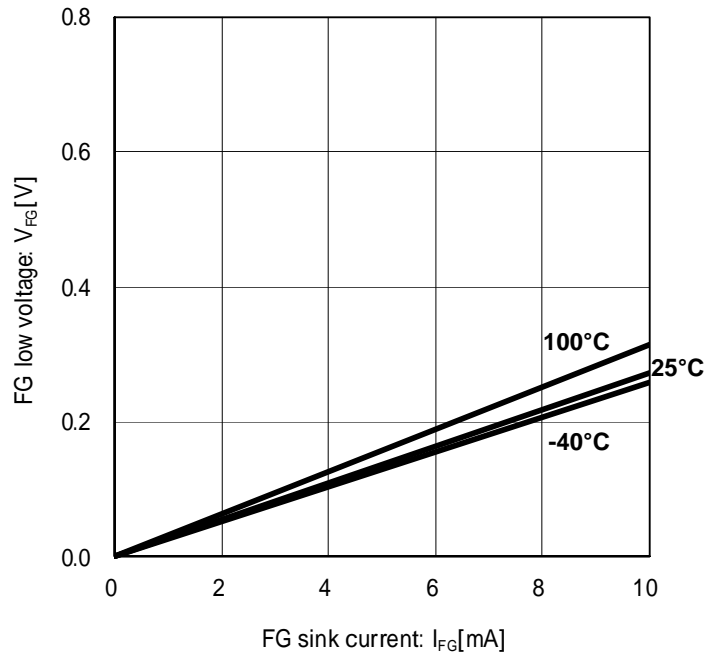

Fig. 8 FG low voltage ($V_{CC}=12V$)

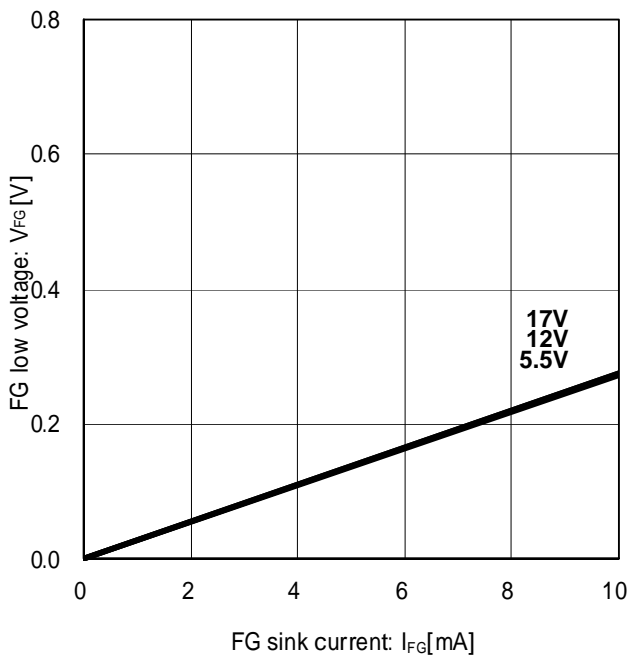

Fig. 9 FG low voltage ($T_a=25^\circ C$)

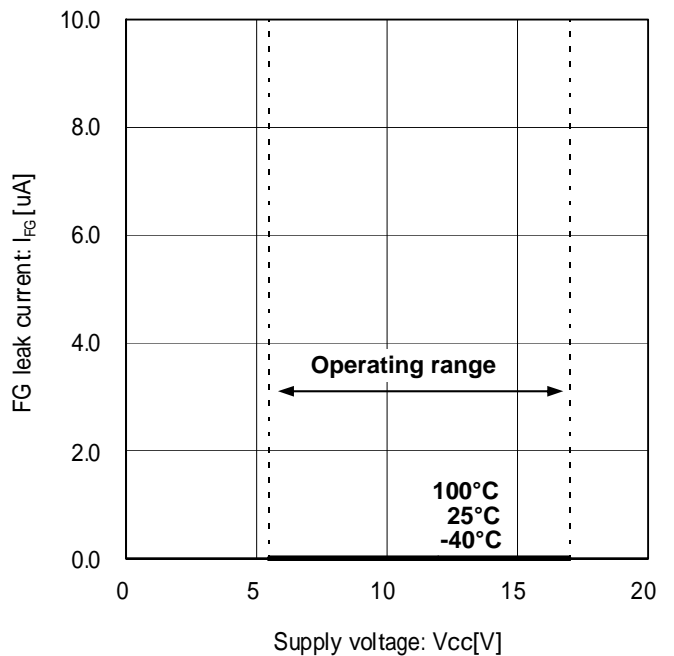

Fig. 10 FG leak current

Typical performance curves(Reference data)

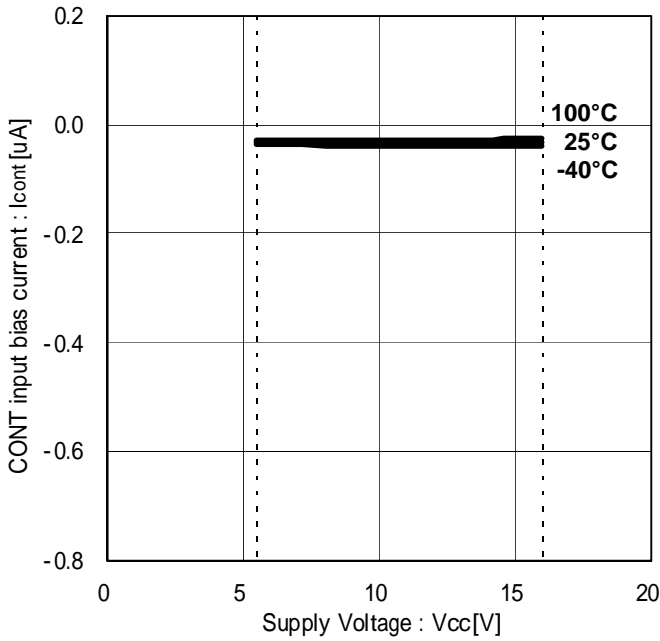

Fig. 11 CONT input bias current

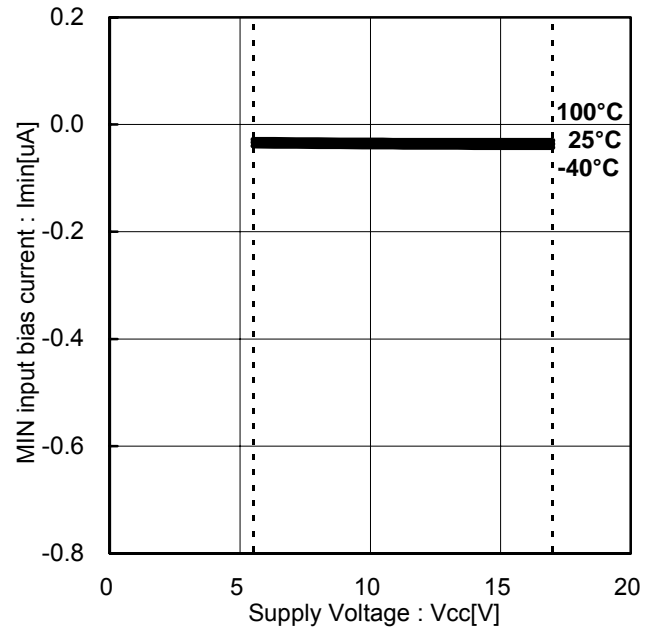

Fig. 12 CONT input bias current

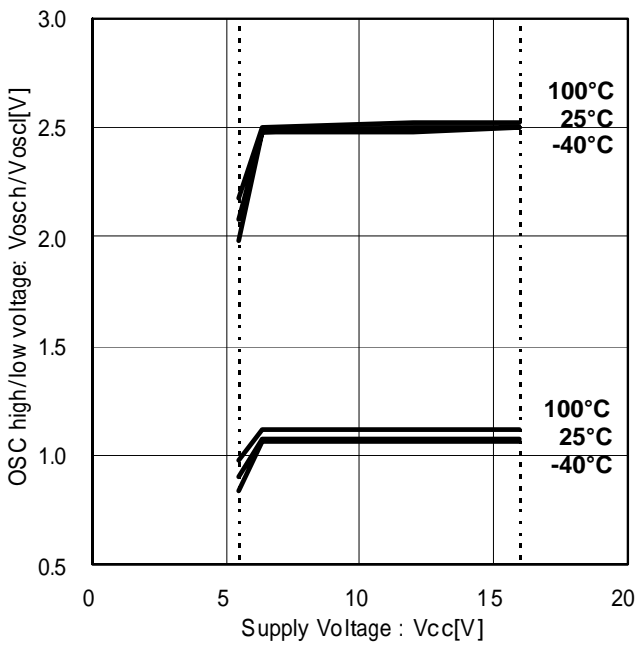

Fig. 13 OSC high/low voltage

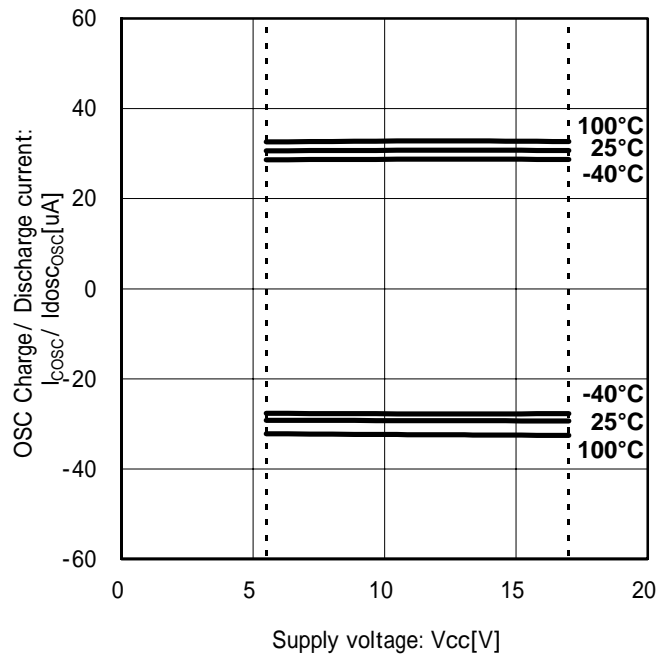

Fig. 14 OSC charge/discharge current

Typical performance curves(Reference data)

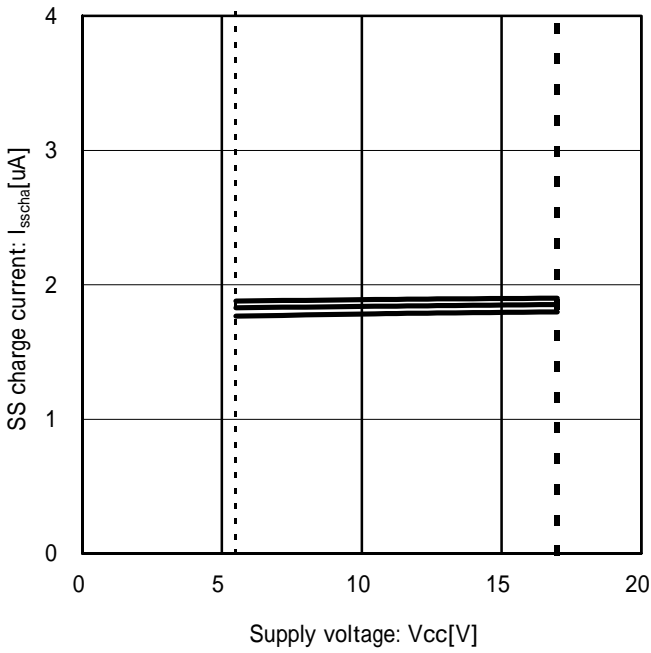

Fig. 15 SS charge current

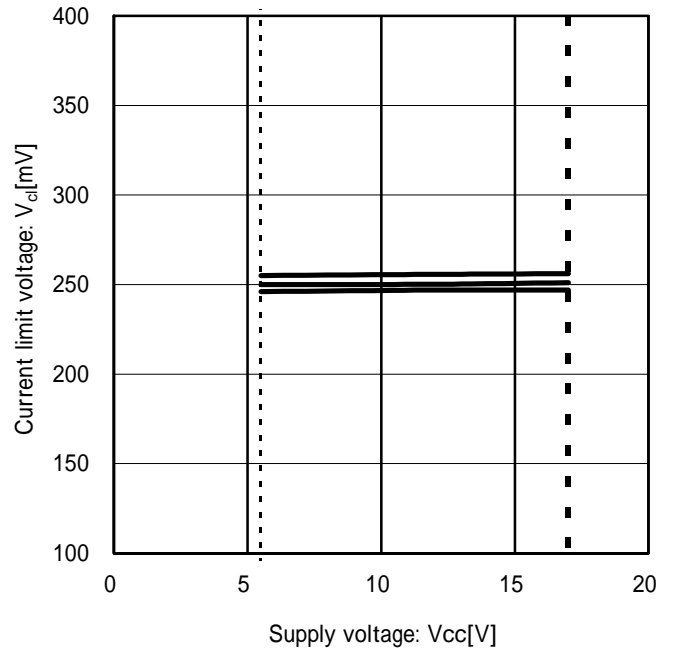

Fig. 16 Current limit voltage

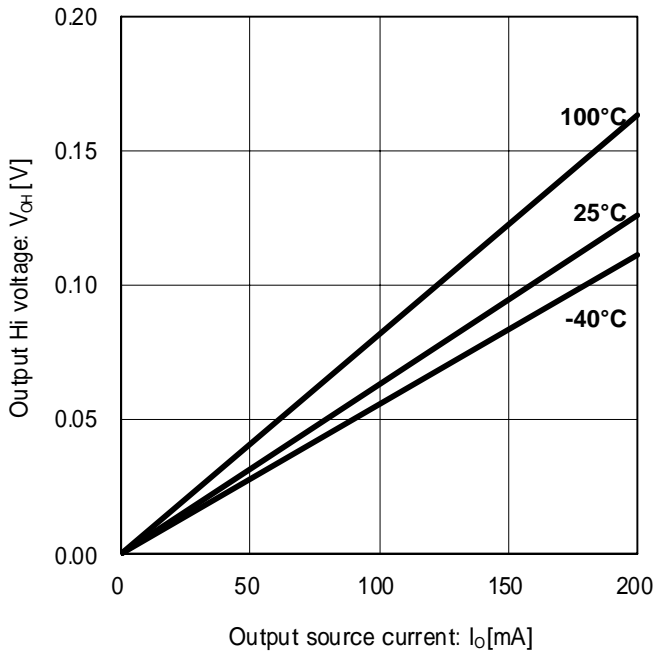

Fig. 17 Output Hi voltage (Vcc=12V)

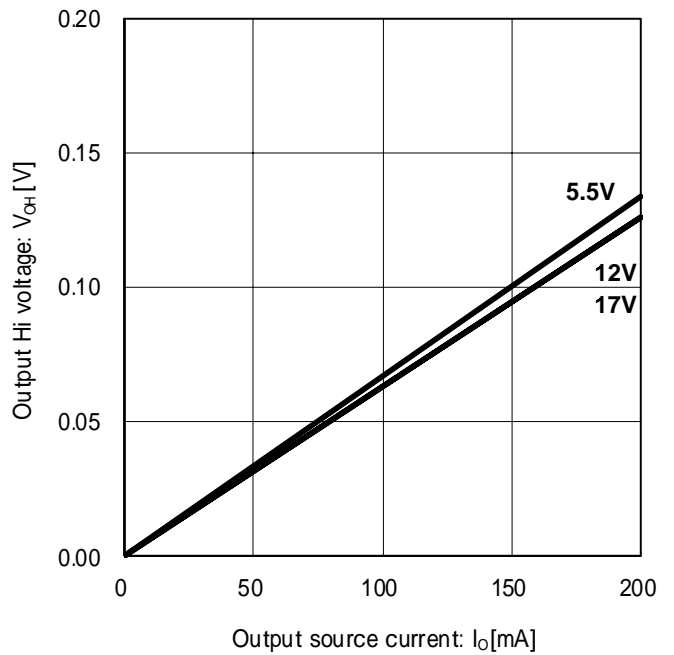

Fig. 18 Output Hi voltage (Ta=25)

Typical performance curve (Reference data)

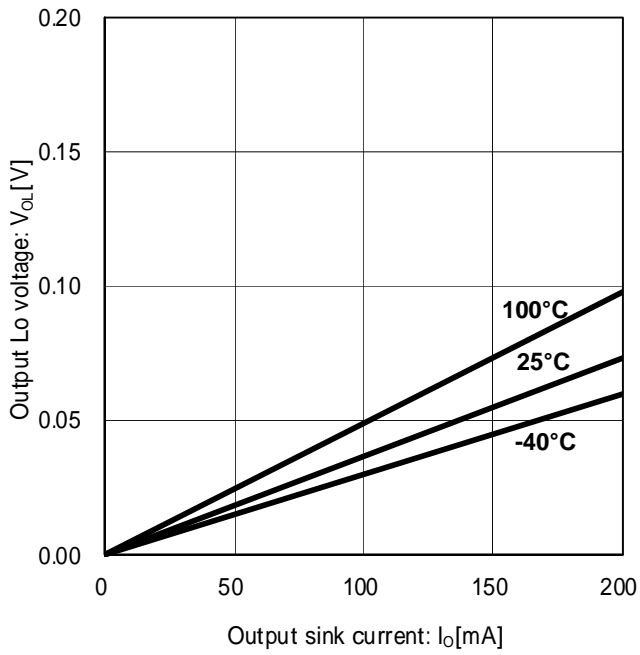

Fig.19 Output Lo voltage ($V_{CC}=12V$)

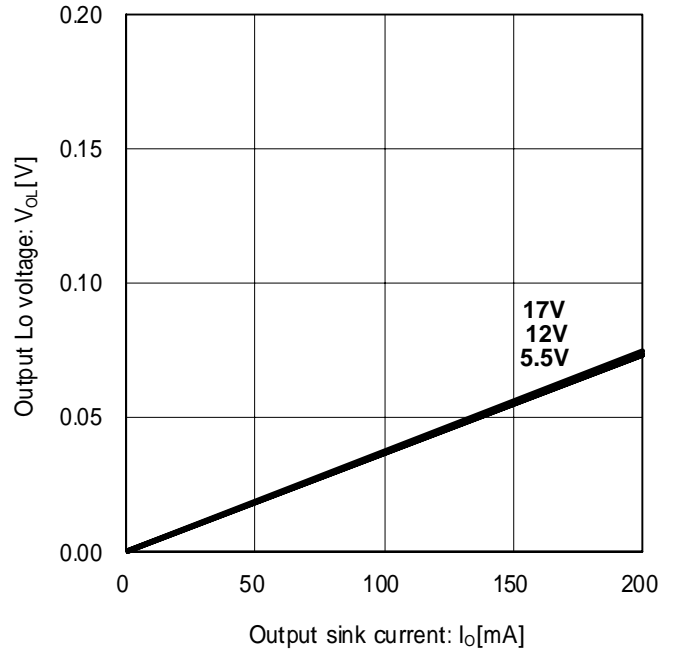

Fig. 20 Output Lo voltage ($T_a=25^\circ C$)

Application circuit example (Constant values are for reference)

- 1) Vcc control motor variable speed for application
 ex. Vcc input voltage control motor constant speed, not necessary to set minimum rotation speed.

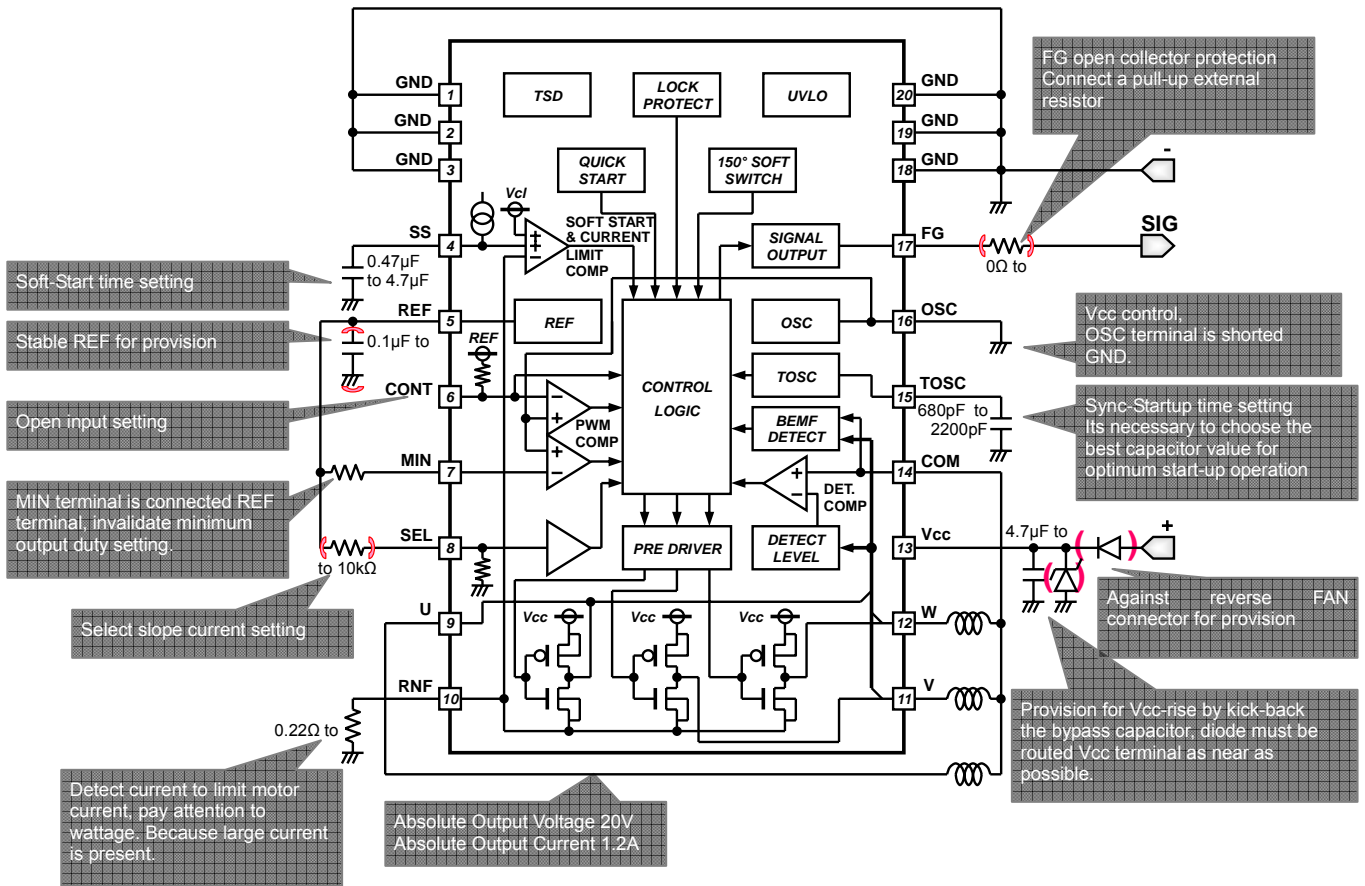

Fig. 21 Vcc control application

Control input terminal setting of Vcc control motor variable speed for application

In case of Vcc control with OSC terminal is shorted GND, control input terminal (CONT, MIN) is shown in Fig. 22,23.

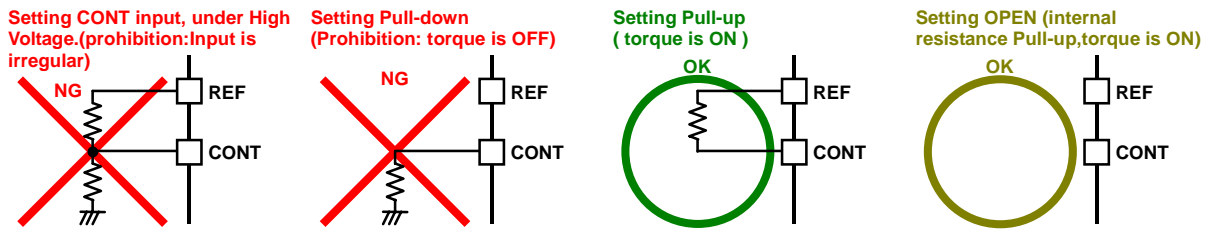

Fig. 22 Vcc control (OSC terminal is shorted GND), CONT terminal setting

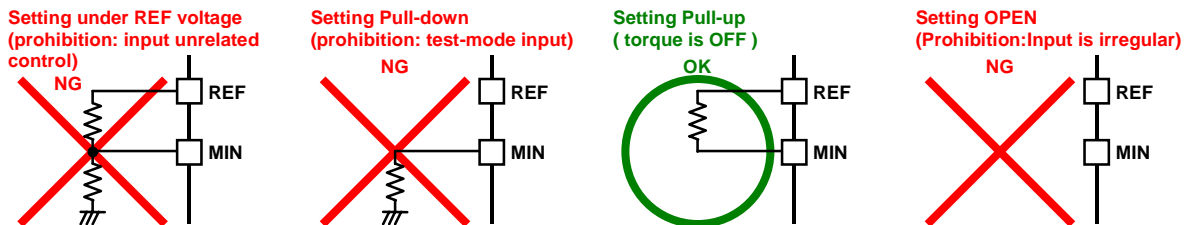

Fig. 23 Vcc control application (OSC terminal is shorted GND), MIN terminal setting

Pay attention to design board

- a) IC Vcc, Motor Output, Motor GND line is as wide as possible
- b) IC GND line is common to other application GND without motor GND. Wire from near the (-) land.
- c) bypass-capacitor, Diode must be routed Vcc terminal as near as possible.

Application circuit example(Constant values are for reference)

2) PWM control motor variable speed for application by PWM duty convert input DC voltage

ex. external PWM signal convert DC voltage, control rotation speed for application. Possible to set minimum rotation speed.

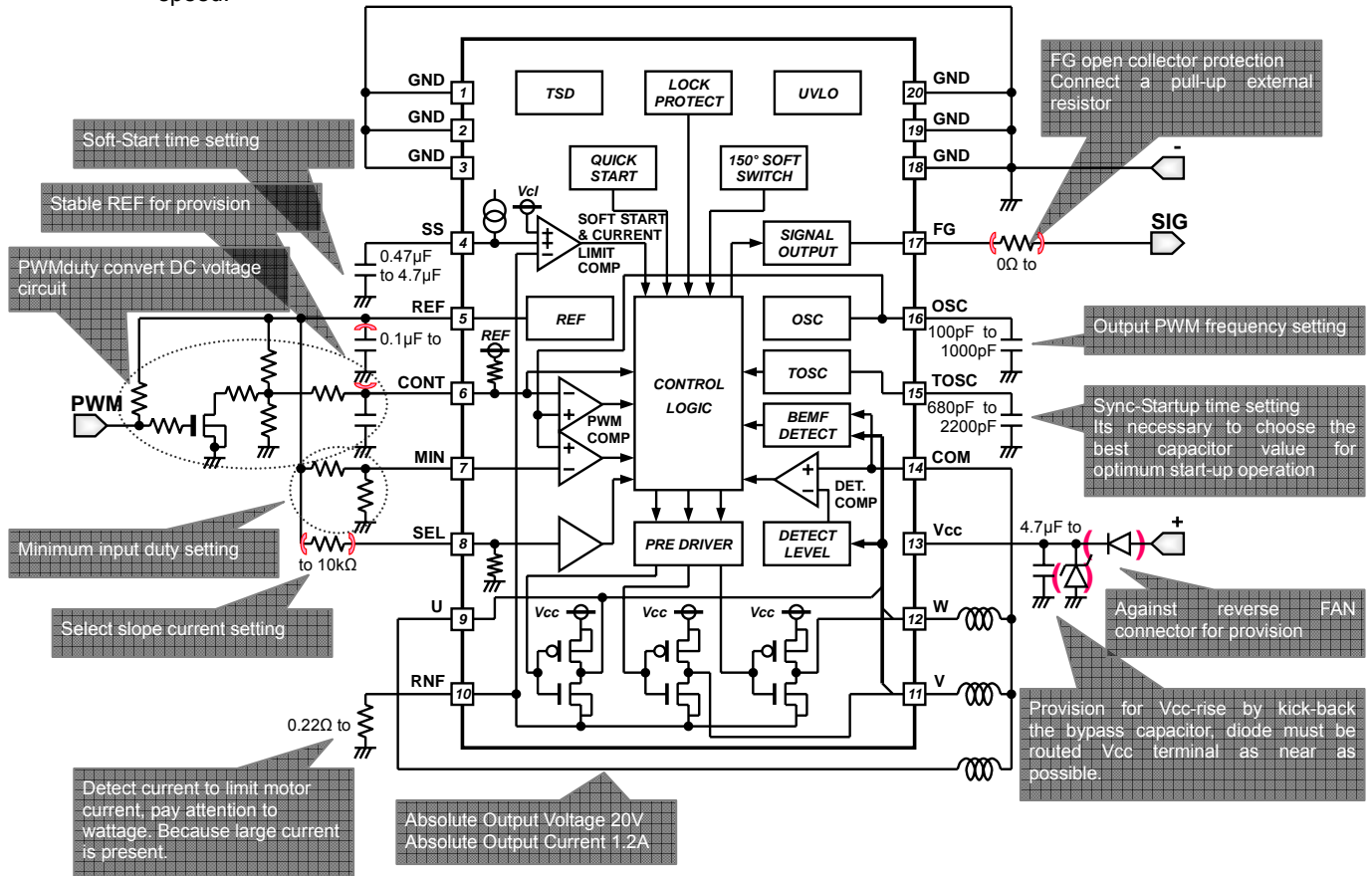

Fig. 24 PWM duty convert DC voltage application

Control input terminal setting of PWM control motor variable speed for application

In case of PWM control with OSC terminal is shorted GND, control input terminal (CONT, MIN) is shown in Fig. 25,26. But CONT,MIN terminal setting Pull-up are state of Motor stop.

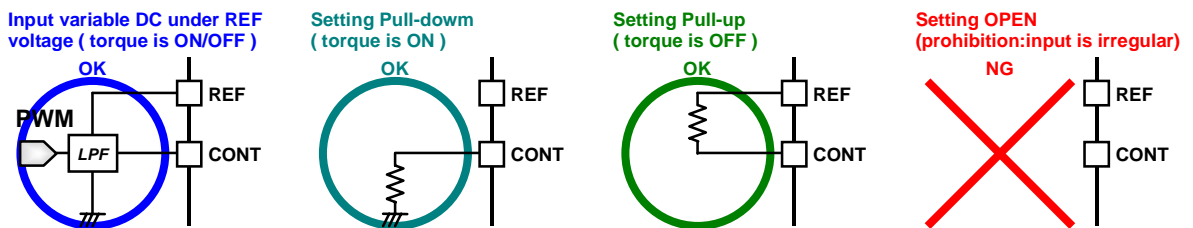

Fig. 25 PWM control by input DC voltage(OSC terminal is CAP to GND), CONT terminal

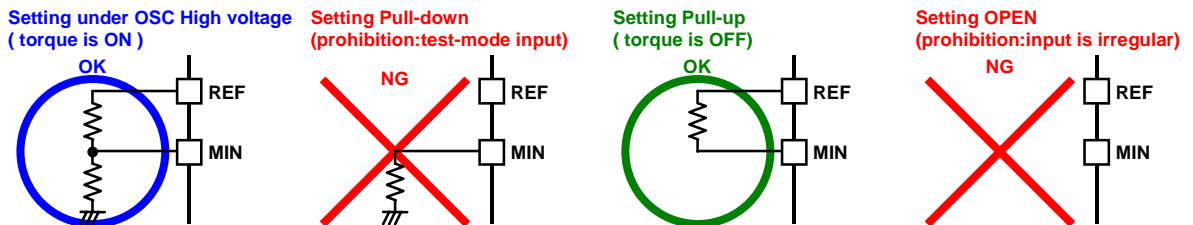

Fig. 26 PWM control by input DC voltage (OSC terminal is CAP to GND), MIN terminal setting

Application circuit example(Constant values are for reference)

3) PWM control motor variable speed for application by input pulse signal (direct PWM input)

ex. external PWM signal duty control directly rotation speed for application. Its not necessary to set minimum rotation speed.

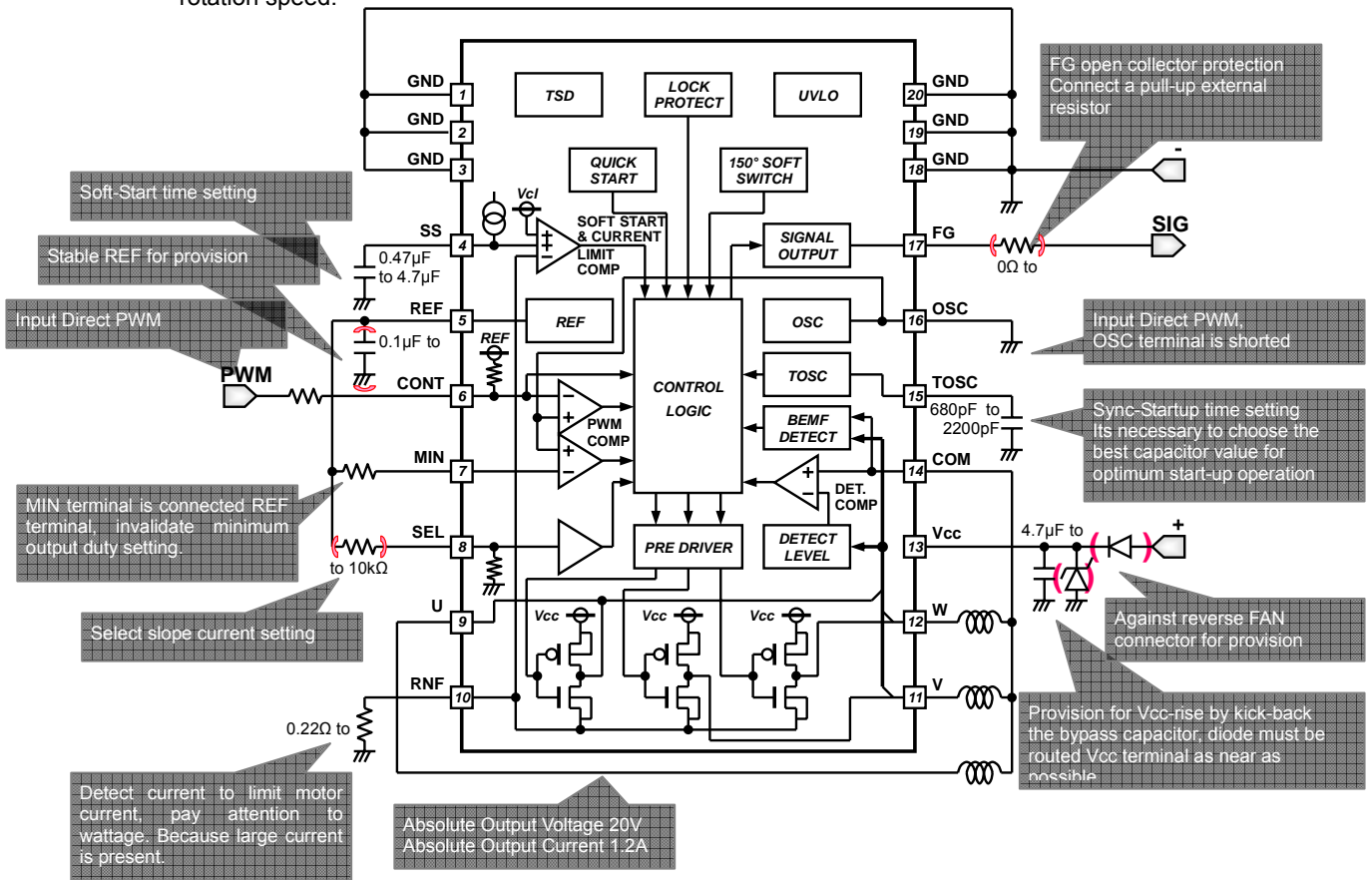

Fig. 27 Direct PWM application

Control input terminal setting of PWM control motor variable speed by pulse input for application

In case of PWM control with OSC terminal is shorted GND, control input terminal (CONT, MIN) is showed in Fig. 28,29. But CONT terminal setting Pull-up or OPEN, Motor is state of constant rotation speed.

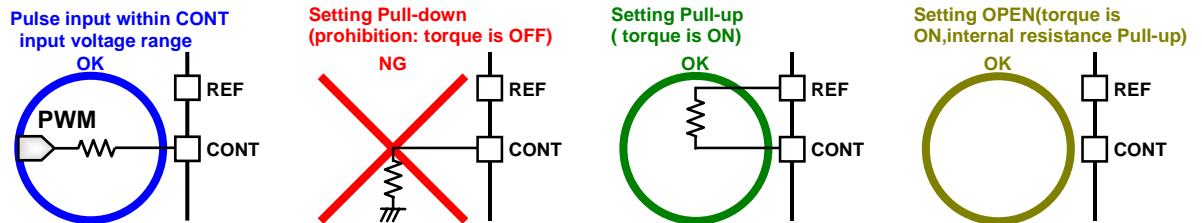

Fig. 28 PWM control by input pulse signal (OSC terminal is shorted GND), CONT terminal setting

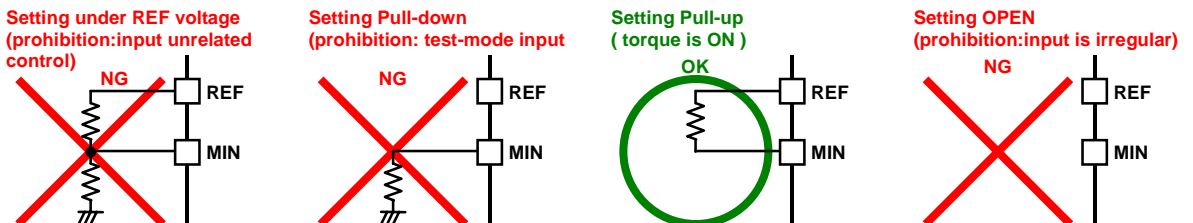

Fig. 29 PWM control by input pulse signal (OSC terminal is shorted GND), MIN terminal setting

Description of operations

1) Sensorless Drive

BD6346FV is a motor driver IC for driving a three-phase brushless DC motor without a hall sensor.

Synchronized start-up and BEMF detection driving

Synchronized start-up way, when BEMF signal isn't detected for constant time at start-up, synchronized start-up mechanism outputs output logic forcibly by using standard synchronized signal (sync signal) and makes motor forward drive. This assistance of motor start-up as constant cycle is synchronized driving mechanism. Synchronized frequency is standard synchronized signal. Driving mechanism changes to BEMF detection driving after detect BEMF signal. Fig. 30, the timing chart (outline) is shown.

FG signal fixed High (masking) during 1.1s (typ.) after Vcc on.

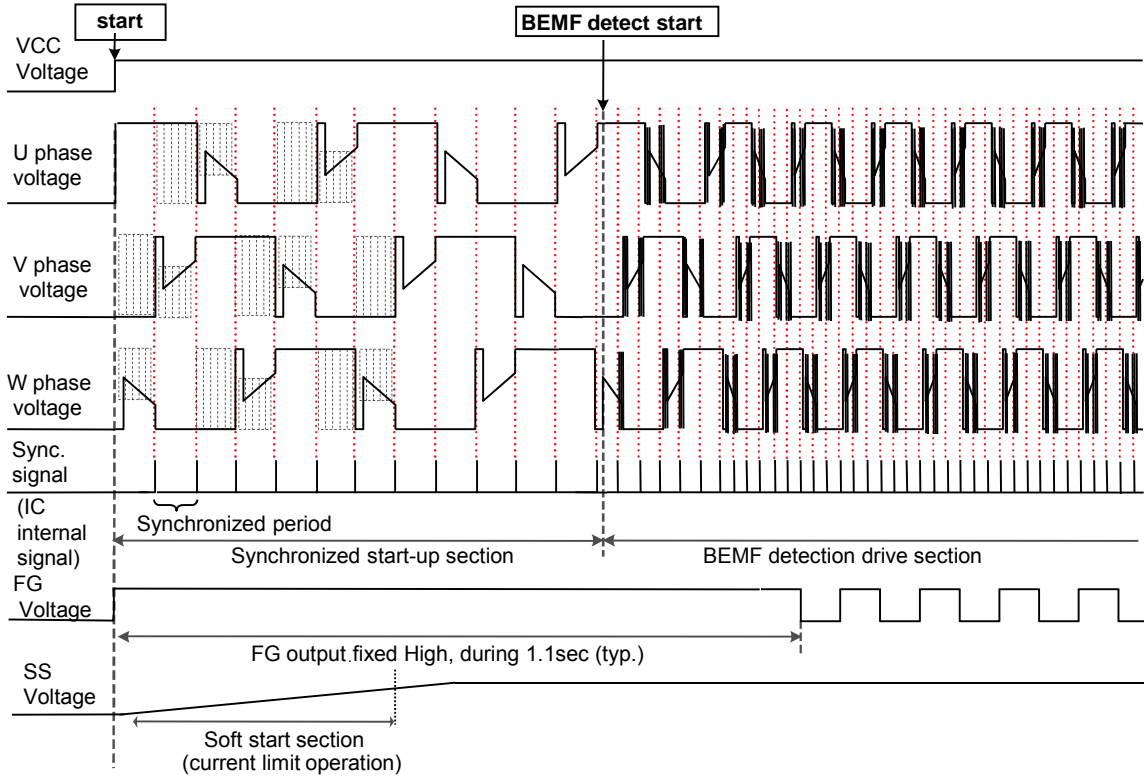

Fig. 30 Synchronized start-up and BEMF detection driving timing chart

Synchronized time (TOSC)

The TOSC terminal starts a self-oscillation by connecting a capacitor between the TOSC terminal and GND terminal. It becomes a start-up frequency, and synchronized time can be adjusted by changing external capacitor. When the capacitor value is small, synchronized time becomes short. It is necessary to choose the best capacitor value for optimum start-up operation. For example external capacitor is 1000pF, synchronized time is 96ms (typ.). 1000pF is recommended for setting value . Relationship between external capacitor and synchronized time is shown in below.

$$T_{tosc}[s] = \{C_{tosc}[F] \times (|I_{dtosc}[A]| + |I_{ctosc}[A]|) \times (V_{tosch}[V] - V_{toscl}[V])\} / (|I_{dtosc}[A]| \times |I_{ctosc}[A]|)$$

$$T_{osc} [s] = 2000 \times T_{tosc}[s]$$

(ex.) When $C_{tosc} = 1000[pF]$, TOSC period is nearly 48us, Synchronized time is nearly 96ms.

$$T_{tosc}[s] = \{1000[pF] \times (|60[\mu A]| + |-60[\mu A]|) \times (2.5[V] - 1.05[V])\} / \{60[\mu A] \times (-60[\mu A])\}$$

$$= 48 \times 10^{-6}[s]$$

$$T_{osc}[s] = 2000 \times 48[\mu s]$$

$$= 96 \times 10^{-3}[s]$$

TOSC Capacitor Synchronized time Table (ref. Val)

TOSC Capacitor (C _{tosc}) [pF]	Synchronized time (T _{osc}) [ms]
680	65
1000	96
2200	211

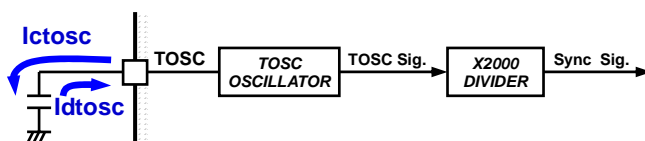

Fig. 31 TOSC Capacitor and IC internal circuit

Setting of Appropriate capacitor value

Appropriate value of synchronized time is differ with characteristic and parameter of motor. Appropriate value decided by start-up confirmation with various capacitor value. Recommend to TOSC_CAP with 1000pF, next confirm to start up with 1200,1500,1700,2000,2200pF... ,and 870,670,470,330pF... ,etc. Appropriate capacitor value is decided after confirm maximum start-up NG value and minimum start-up NG value. For example, small BEMF voltage motor tends to small capacitor value. Set capacitor value after confirm sufficiently. Setting TOSC_CAP value range is from 680pF to 2200pF.

1) Sensorless-drive (continuance)

PWM soft-switched driving

PWM soft-switched driving, When each phase changed, change smoothly each phase current. For purpose, silent and low vibration motor driving.

In Fig. 32, the timing charts of the output signals from U,V,W phase as well as the FG terminal is shown with PWM soft-switched driving section. Assuming that a three-slot tetrode motor is used, two pulse outputs of FG are produced for one motor cycle. The three phases are excited in the order of U,V, and W phases.

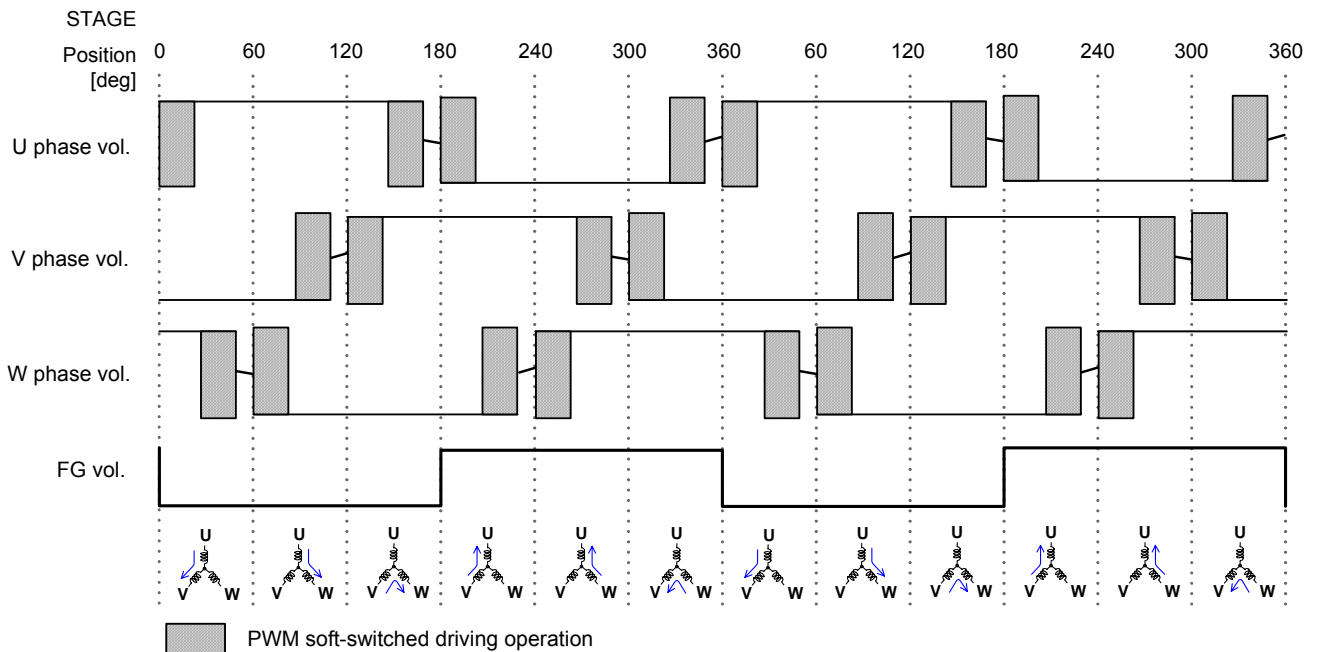

Fig. 32 BEMF detection driving (full-torque) and PWM soft-switched driving timing

STAGE	Motor Output		
	Motor U output	Motor V output	Motor W output
1	H	L	Hi-Z
2	H	Hi-Z	L
3	Hi-Z	H	L
4	L	H	Hi-Z
5	L	Hi-Z	H
6	Hi-Z	L	H

note) Output pattern proceed in numeric 1 2 3 ~ 6 1.
H; High, L; Low, Hi-Z; High impedance

Description of operations

2) Lock Protection Feature, Automatic Recovery Circuit

To prevent passing a coil current on any phase when a motor is locked, it is provided with a function, which can turn OFF the output for a certain period of time and then automatically restore itself to the normal operation. During the motor rotation, an appropriate logic based on the induced electromotive voltage can be continuously given to each phase; on the other hand, when the motor is locked, no induced electromotive voltage is obtained. Utilizing this phenomenon to take a protective against locking, when the induced electromotive voltage is not detected for a predetermined period of time (TON typ. 1.0s), it is judged that the motor is locked and the output is turned OFF for a predetermined period of time (TOFF typ. 5.0s). In Fig. 33, the timing chart is shown.

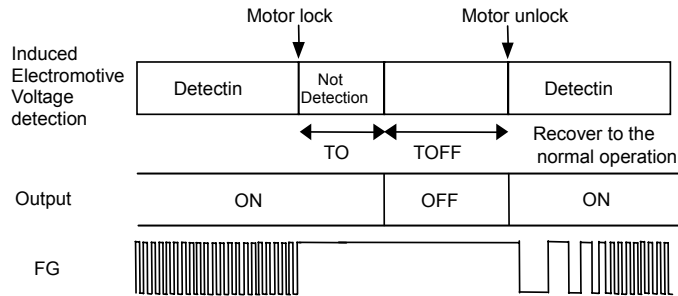

Fig. 33 Lock protection (Internal counter way) timing chart

3)UVLO (Under voltage lock out circuit)

In the operation area under the guaranteed operating power supply voltage of 5.5V (typ.), the transistor on the output can be turned OFF at a power supply voltage of 3.9V (typ.). A hysteresis width of 250mV is provided and a normal operation can be performed at 4.15V(typ.). This function is installed to prevent unpredictable operations, such as a large amount of current passing through the output, by means of intentionally turning OFF the output during an operation at a very low power supply voltage which may cause an abnormal function in the internal circuit. About turning off a output voltage at UVLO, It becomes a OFF mode.
(Upper MOS FET and Under MOS FET are turned OFF.)

Description of operations

4) PWM speed control

Rotation speed change by Motor output (U,V,W) PWM duty., PWM operation are in below two ways.

- a) OSC terminal connect CAP to GND, DC voltage input to CONT terminal, MIN terminal.
- b) OSC terminal is shorted GND, Pulse signal input to CONT terminal.

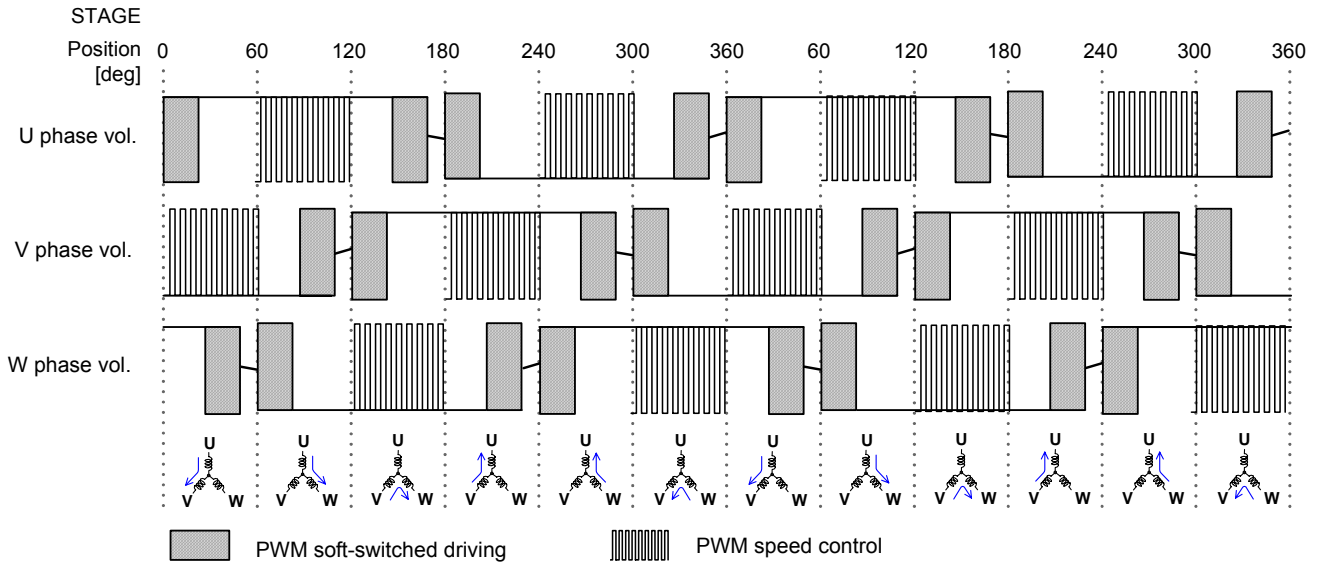

Fig. 34 BEMF detection driving (PWM control) and PWM soft-switching timing chart

- a) PWM control, OSC terminal connect CAP to GND, DC voltage input to CONT terminal, MIN terminal.

As shown in Fig. 36, to change the output ON time, a DC input voltage from TH terminal is compared to the triangle wave produced by the OSC circuit. MIN terminal is use to set the minimum rotational speed. ON time is determined by either CONT terminal voltage or MIN terminal voltage, whichever is lower.

- OSC voltage > CONT voltage (MIN voltage): PWM output phase ON
- OSC voltage < CONT voltage (MIN voltage): PWM output phase OFF

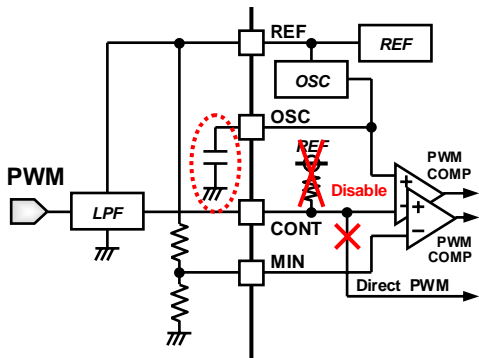

Fig. 35 DC input application

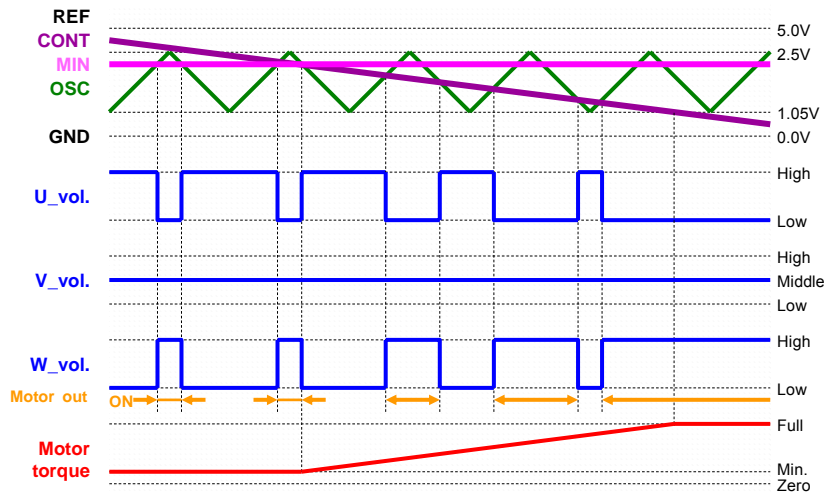

Fig. 36 DC input PWM control timing chart (ex. (U, V, W) = (L, M, H))

Resistor divider of the internal regulator (REF) terminal equal to typ. 5.0V) generates OSC high and low voltage level of typically 2.5V and 1.05V respectively, and the ratio of those voltages is designed not to fluctuate easily. When the input voltage at TH terminal is constant, the effect of OSC H/L voltage fluctuation is large. However, an application can be made which is not easily affected by the fluctuation of the triangular wave by generating CONT voltage from REF. For application that requires high precision, determine the value with sufficient margin after taking full consideration of external components. It should be detected constant value with margin for application of more severe precision.

Output frequency setting

The PWM Frequency (Fosc) in which the motor is operated is set according to the capacitor value (Cosc) connected to OSC terminal.

$$Fosc[Hz] = \{ |I_{dosc}[A] \times I_{cosc}[A] \} / \{ Cosc[F] \times (|I_{dosc}[A] | + |I_{cosc}[A] |) \times (Vosch[V] - Voscl[V]) \}$$

(ex.) When Cosc is 330pF, the PWM output frequency is 31kHz.

$$Fosc[Hz] = \{ |30[\mu A] \times (-30[\mu A]) \} / \{ 330[pF] \times (|30[\mu A] | + |-30[\mu A] |) \times (2.5[V] - 1.05[V]) \}$$

$$= 31 \times 10^3 [Hz]$$

Description of operations

- 4) PWM speed control (continuance)
 - b) PWM control: OSC terminal is shorted GND, Pulse signal input to CONT terminal.

In Fig. 38, PWM control, pulse signal input to CONT terminal. Motor output PWM duty change by input pulse signal duty. MIN terminal should be pulled up REF terminal.

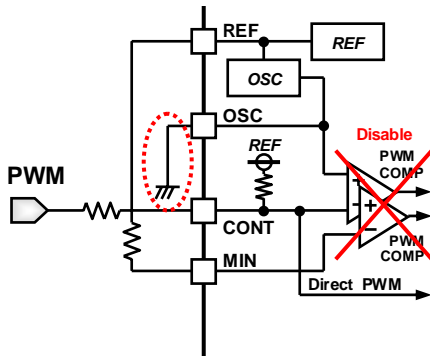

Fig. 37 Input pulse application

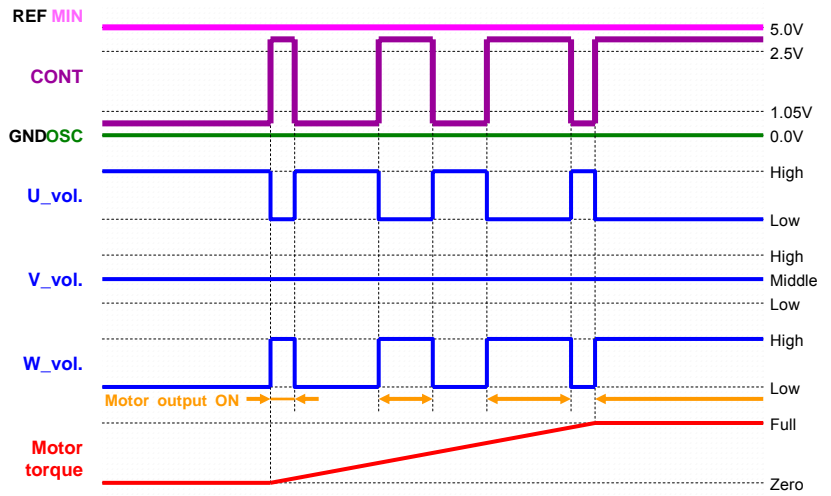

Fig. 38 Input pulse PWM control timing chart (ex. (U, V, W) = (L, M, H))

5) Current limit

A current passing through the motor coil can be detected on the output current detection resistance to prohibit a current flow larger than a current limit value (motor output off). The current limit value is determined by setting of the IC internal limit (Vcl) :250mV (typ.), and the output current detection resistance value using the following in below equation.

$$I_o[A] = V_{cl}[V] / R1[\Omega] \quad P_R[W] = V_{cl}[V] \times I_o[A]$$

$$= 250[mV] / 0.33[\Omega] \quad = 250[mV] \times 0.758[A]$$

$$= 0.758[A] \quad = 0.19[W]$$

When no-use current limit function, RNF terminal is shorted GND.

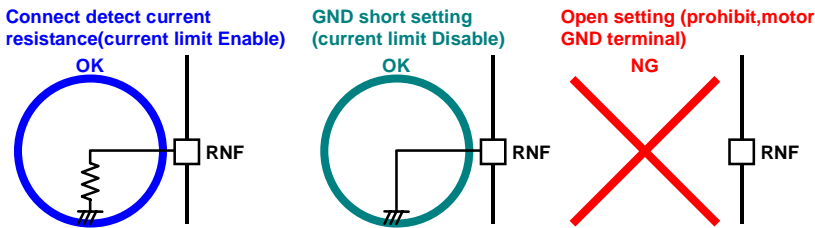

Fig. 39 Current limit function, RNF terminal setting

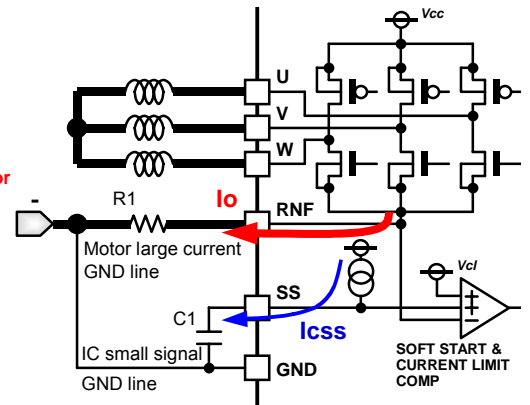

Fig. 40 small signal and large current GND line separate

In Fig. 40, IC small signal GND line should be separated Motor large current GND line connected R1. Same as soft start Capacitor. (P.4 Pay attention to design board(b)) item reference)

6) Soft start

To prevent lush current, slowly up to rotation speed, when motor start in VCC on, quick start, restart lock detect on etc. Soft start time set by SS terminal connected CAP to charge current. No use soft start, SS terminal set open. 1uF is recommended for setting value at first, or 0.47uF-4.7uF.

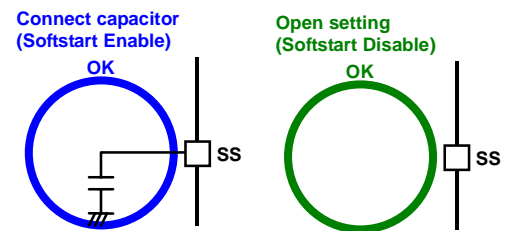

Fig. 41 Soft start function, SS terminal setting

Description of operations

6) Soft start (continuance)

In Fig. 40, SS terminal charge current (Icss) is 1.9uA (typ.), Set SS terminal connect Capacitor (C1) and cut motor output current (Icut), lead to that current time(Tss) in below equation. Icss1 is reduced 1/10 SS terminal charge current (Icss) in internal IC.

$$T_{ss}[s] = (C1[F] \times I_{cut}[A] \times R1[\Omega]) / I_{css1}[A]$$

(ex.) Assuming that C1 = 1.0[μF], Icut = 0.8[A], R1 = 0.1[Ω] then, soft-start time is 421ms

$$T_{ss}[s] = (1.0[\mu F] \times 0.8[A] \times 0.1[\Omega]) / (1.9/10)[uA]$$

$$= 421 \times 10^{-3}[s]$$

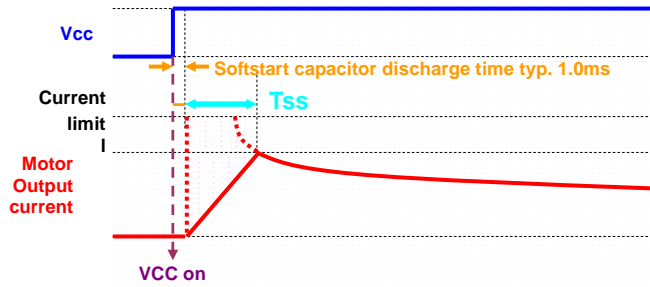

Fig. 42 Characteristic of motor output current at soft-start setting

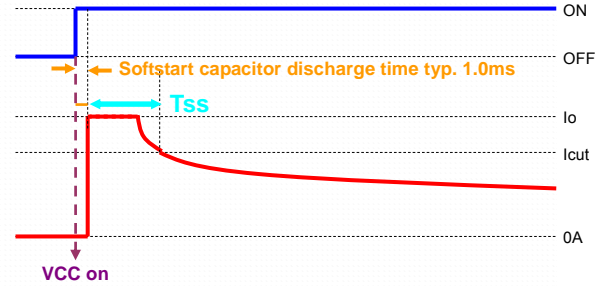

Fig. 43 Characteristic of motor output current at no soft-start setting

7) Quick start

When torque off logic is inputted by the control signal over fixed time (80us), the lock protection function becomes off. And the motor could restart quickly at the timing of control signal in input.

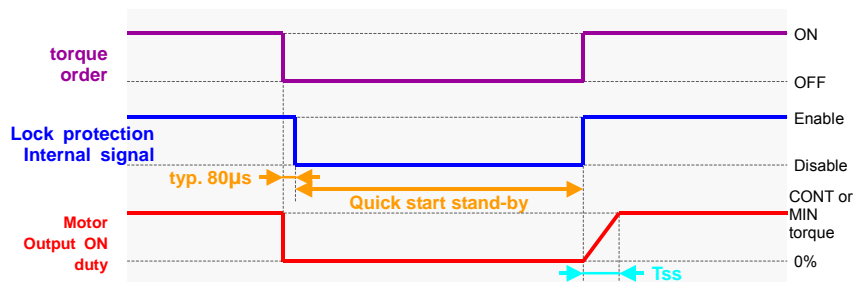

Fig. 44 torque order and quick start, timing chart

8) Select of drive current slope

By changing two steps PWM soft-switching section in SEL terminal, can adjust each phase slope at motor driving. SEL terminal pull down resistance internal IC. SEL terminal is to pull-up REF terminal, SEL input signal is high. When SEL terminal pull up REF terminal, PWM soft-switching section is more wide to smoothly current slope than SEL terminal OPEN, BEMF detection section is more narrow. Please select to fit application.

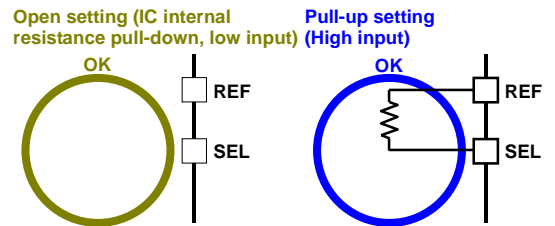

Fig. 45 Slope of drive current, SEL setting

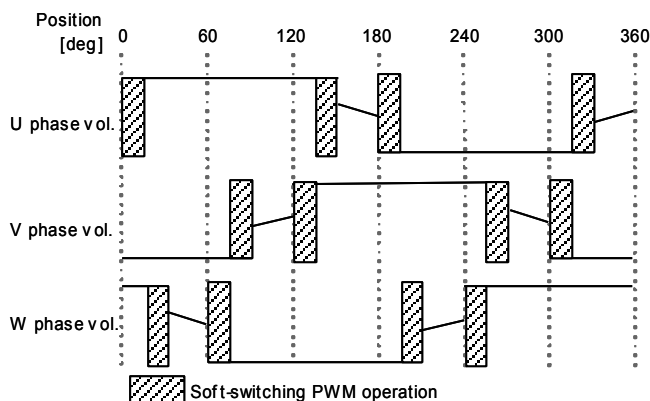

Fig. 46 SEL open, drive waveform

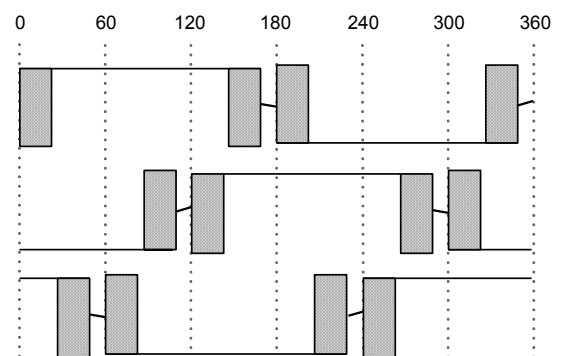

Fig. 47 SEL pull-up, drive waveform

Safety measure

1) Reverse connection protection diode

Reverse connection of power results in IC destruction as shown in Fig. 48. When reverse connection is possible, reverse connection protection diode must be added between power supply and V_{CC} .

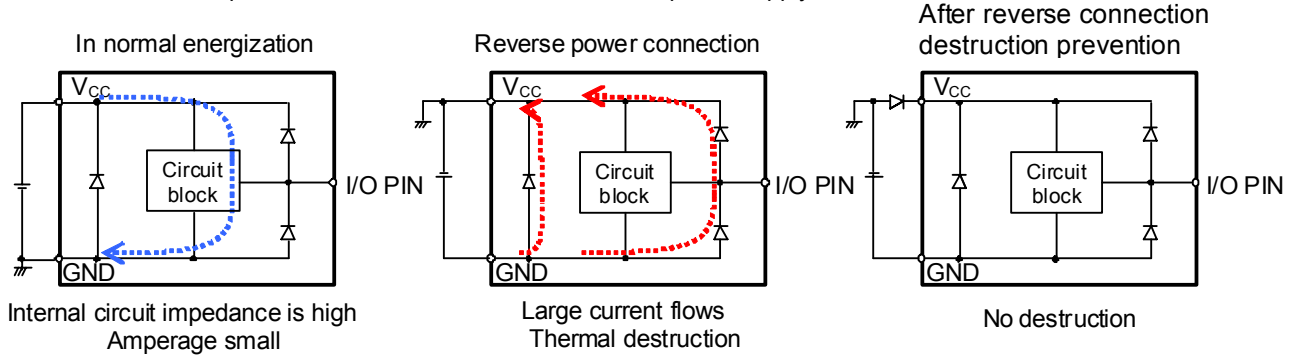

Fig. 48 Flow of current when power is connected reversely

2) Measure against V_{CC} voltage rise by back electromotive force

Back electromotive force (Back EMF) generates regenerative current to power supply. However, when reverse connection protection diode is connected, V_{CC} voltage rises because the diode prevents current flow to power supply.

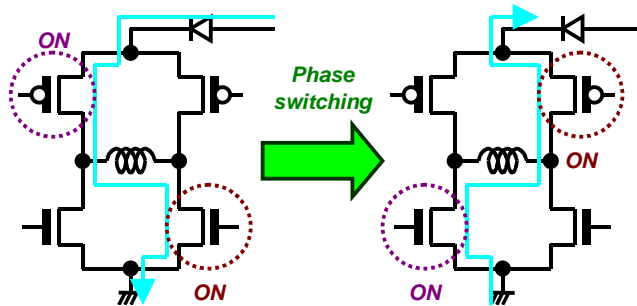

Fig. 49 V_{CC} voltage rise by back electromotive force

When you use reverse connection protection diode, Please connect Zener diode, or capacitor. Do not exceed absolute maximum ratings $V_{CC}=20V$.

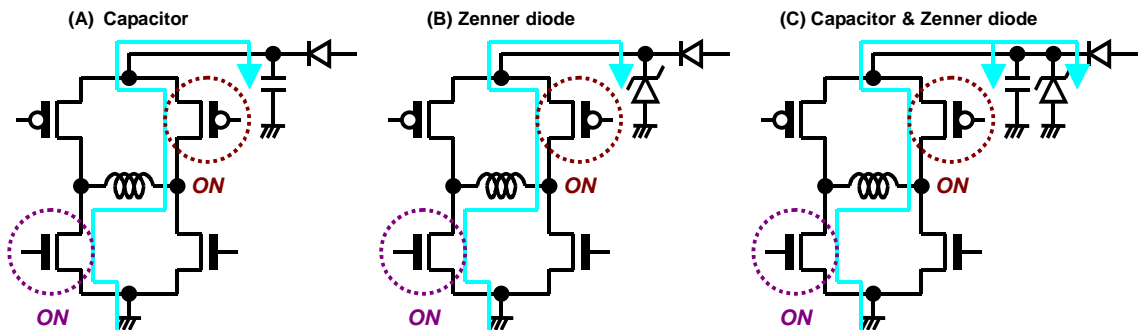

Fig. 50 Measure against V_{CC} voltage rise

3) Problem of GND line PWM switching

Do not perform PWM switching of GND line because GND terminal potential cannot be kept to a minimum.

4) FG output

FG output is an open drain and requires pull-up resistor. Adding resistor R1 can protect the IC. An excess of absolute maximum rating, when FG output terminal is directly connected to power supply, could damage the IC.

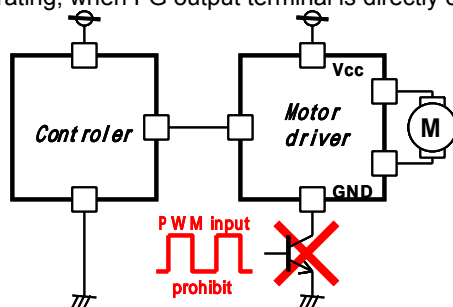

Fig. 51 GND line PWM switching prohibited

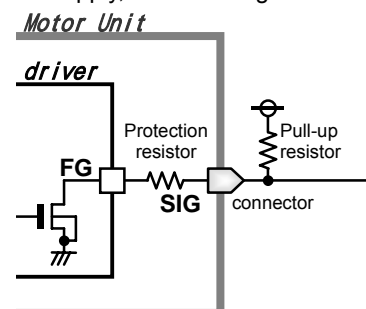

Fig. 52 Protection of FG terminal

Power dissipation

Power dissipation (total loss) indicates the power that can be consumed by IC at Ta=25°C (normal temperature). IC is heated when it consumes power, and the temperature of IC chip becomes higher than ambient temperature. The temperature that can be accepted by IC chip depends on circuit configuration, manufacturing process, etc, and consumable power is limited. Power dissipation is determined by the temperature allowed in IC chip (maximum junction temperature) and thermal resistance of package (heat dissipation capability). The maximum junction temperature is in general equal to the maximum value in the storage temperature range.

Heat generated by consumed power of IC is radiated from the mold resin or lead frame of package. The parameter which indicates this heat dissipation capability (hardness of heat release) is called heat resistance, represented by the symbol θ_{ja} [°C/W]. This heat resistance can estimate the temperature of IC inside the package. Fig. 53 shows the model of heat resistance of the package. Heat resistance θ_{ja} , ambient temperature Ta, junction temperature Tj, and power consumption P can be calculated by the equation below:

$$\theta_{ja} = (T_j - T_a) / P \text{ [}^\circ\text{C/W]}$$

Thermal derating curve indicates power that can be consumed by IC with reference to ambient temperature. Power that can be consumed by IC begins to attenuate at certain ambient temperature. This gradient is determined by thermal resistance θ_{ja} . Thermal resistance θ_{ja} depends on chip size, power consumption, package ambient temperature, packaging condition, wind velocity, etc., even when the same package is used. Thermal derating curve indicates a reference value measured at a specified condition. Fig. 54 shows a thermal derating curve (Value when mounting FR4 glass epoxy board 70[mm]×70[mm] × 1.6[mm] (copper foil area below 3[%]))

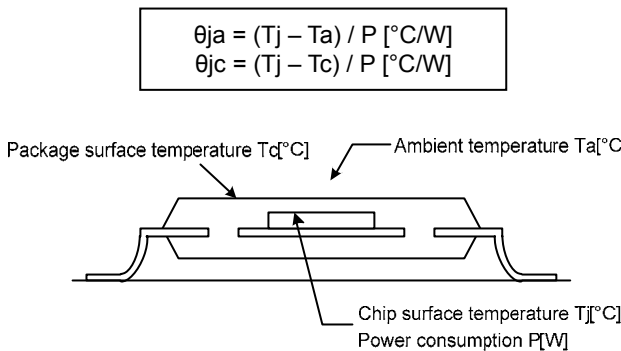

Fig. 53 Thermal resistance

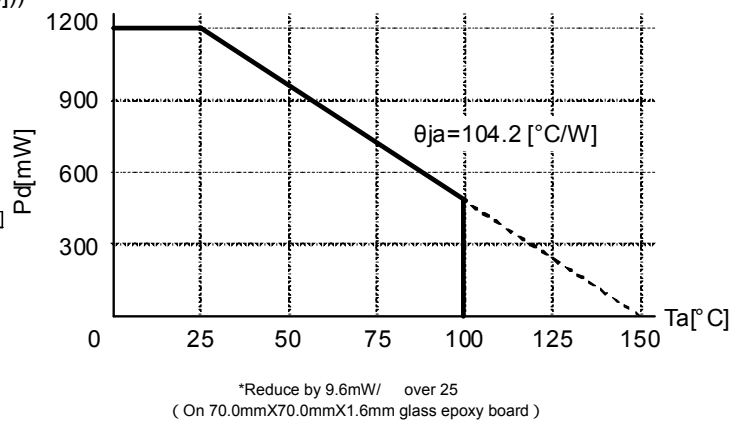
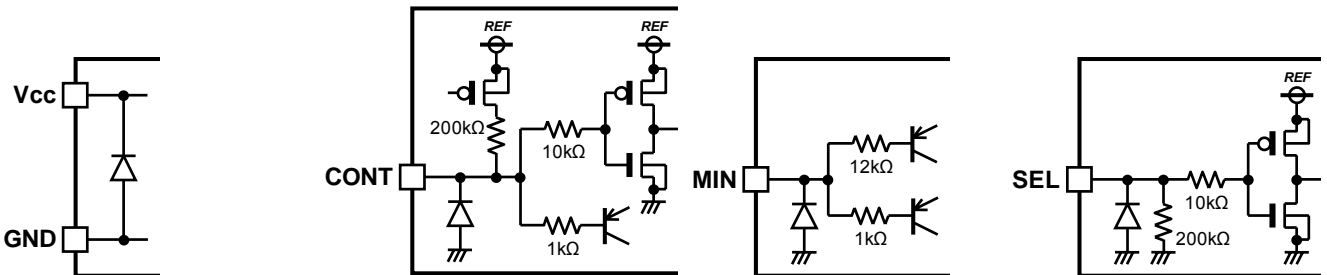

Fig. 54 Thermal derating curve

Equivalent circuit (resistor is reference value)

- 1) Vcc,GND terminal
- 2) CONT terminal
- 3) MIN terminal
- 4) SEL terminal



- 5) REF terminal
- 6) OSC,TOSC terminal
- 7) SS terminal
- 8) U,V,W,RNF terminal

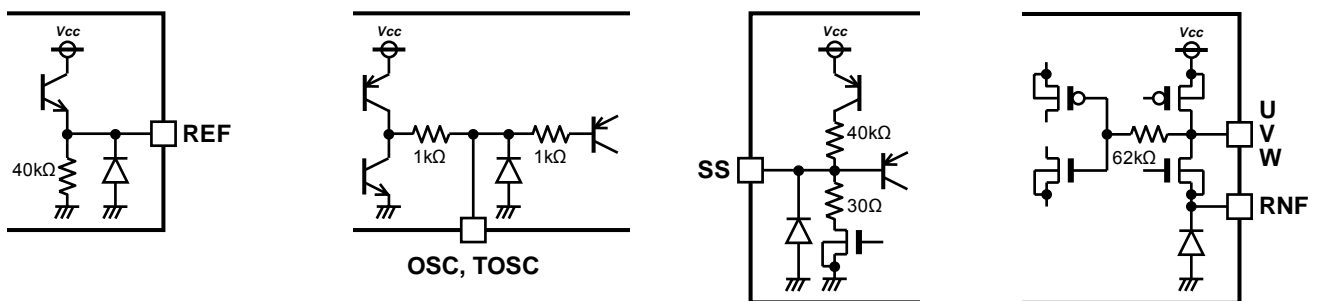

- 9) COM terminal
- 10) FG terminal

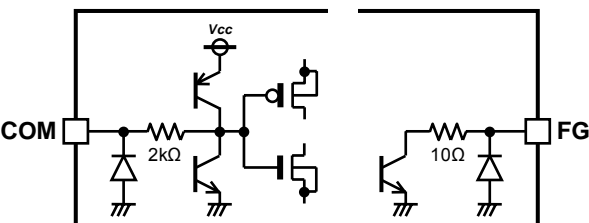

Operational Notes

- 1) Absolute maximum ratings
An excess in the absolute maximum ratings, such as supply voltage, temperature range of operating conditions, etc., can break down the devices, thus making impossible to identify breaking mode, such as a short circuit or an open circuit. If any over rated values will expect to exceed the absolute maximum ratings, consider adding circuit protection devices, such as fuses.
- 2) Connecting the power supply connector backward
Connecting of the power supply in reverse polarity can damage IC. Take precautions when connecting the power supply lines. An external direction diode can be added.
- 3) Power supply line
Back electromotive force causes regenerated current to power supply line, therefore take a measure such as placing a capacitor between power supply and GND for routing regenerated current. And fully ensure that the capacitor characteristics have no problem before determine a capacitor value. (When applying electrolytic capacitors, capacitance characteristic values are reduced at low temperatures)
- 4) GND potential
It is possible that the motor output terminal may deflect below GND terminal because of influence by back electromotive force of motor. The potential GND terminal must be minimum potential in all operating conditions, except that the levels of the motor outputs terminals are under GND level by the back electromotive force of the motor coil. Also ensure that all terminals except GND and motor output terminals do not fall below GND voltage including transient characteristics. Malfunction may possibly occur depending on use condition, environment, and property of individual motor. Please make fully confirmation that no problem is found on operation of IC.
- 5) Thermal design
Use a thermal design that allows for a sufficient margin in light of the power dissipation (Pd) in actual operating conditions.
- 6) Inter-pin shorts and mounting errors
Use caution when positioning the IC for mounting on printed circuit boards. The IC may be damaged if there is any connection error or if pins are shorted together.
- 7) Actions in strong electromagnetic field
Use caution when using the IC in the presence of a strong electromagnetic field as doing so may cause the IC to malfunction.
- 8) ASO
When using the IC, set the output transistor so that it does not exceed absolute maximum ratings or ASO.
- 9) Thermal shut down circuit
The IC incorporates a built-in thermal shutdown circuit (TSD circuit). Operation temperature is 175°C (typ.) and has a hysteresis width of 25°C (typ.). When IC chip temperature rises and TSD circuit works, the output terminal becomes an open state. TSD circuit is designed only to shut the IC off to prevent thermal runaway. It is not designed to protect the IC or guarantee its operation. Do not continue to use the IC after operation this circuit or use the IC in an environment where the operation of this circuit is assumed.
- 10) Testing on application boards
When testing the IC on an application board, connecting a capacitor to a pin with low impedance subjects the IC to stress. Always discharge capacitors after each process or step. Always turn the IC's power supply off before connecting it to or removing it from a jig or fixture during the inspection process. Ground the IC during assembly steps as an antistatic measure. Use similar precaution when transporting or storing the IC.
- 11) GND wiring pattern
When using both small signal and large current GND patterns, it is recommended to isolate the two ground patterns, placing a single ground point at the ground potential of application so that the pattern wiring resistance and voltage variations caused by large currents do not cause variations in the small signal ground voltage. Be careful not to change the GND wiring pattern of any external components, either.
- 12) Capacitor between output and GND
When a large capacitor is connected between output and GND, if Vcc is shorted with 0V or GND for some cause, it is possible that the current charged in the capacitor may flow into the output resulting in destruction. Keep the capacitor between output and GND below 100uF.
- 13) IC terminal input
When Vcc voltage is not applied to IC, do not apply voltage to each input terminal. When voltage above Vcc or below GND is applied to the input terminal, parasitic element is actuated due to the structure of IC. Operation of parasitic element causes mutual interference between circuits, resulting in malfunction as well as destruction in the last. Do not use in a manner where parasitic element is actuated.
- 14) In use
We are sure that the example of application circuit is preferable, but please check the character further more in application to a part that requires high precision. In using the unit with external circuit constant changed, consider the variation of externally equipped parts and our IC including not only static character but also transient character and allow sufficient margin in determining.

status of this document

The English version of this document is formal specification. A customer may use this translation version only for a reference to help reading the formal version.

If there are any differences in translation version of this document formal version takes priority

Physical Dimension Tape and Reel Information

SSOP-B20

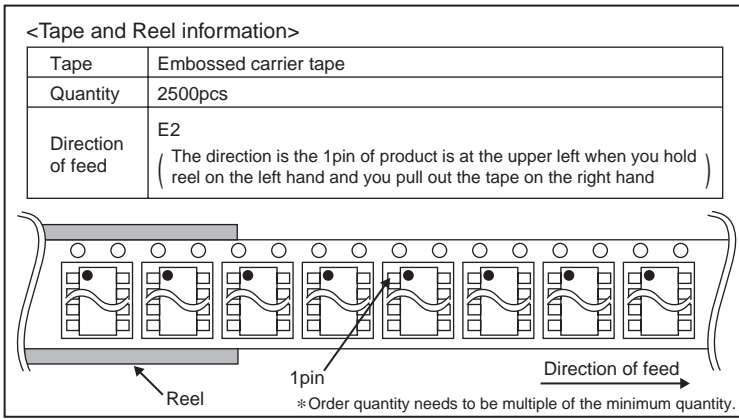
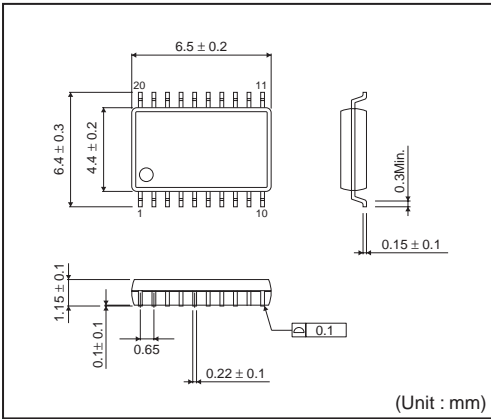

Marking Diagram

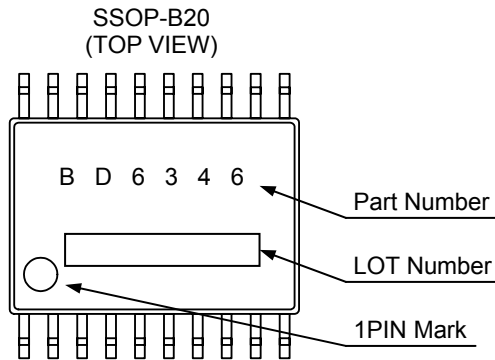

Notice

Precaution on using ROHM Products

- Our Products are designed and manufactured for application in ordinary electronic equipments (such as AV equipment, OA equipment, telecommunication equipment, home electronic appliances, amusement equipment, etc.). If you intend to use our Products in devices requiring extremely high reliability (such as medical equipment ^(Note 1), transport equipment, traffic equipment, aircraft/spacecraft, nuclear power controllers, fuel controllers, car equipment including car accessories, safety devices, etc.) and whose malfunction or failure may cause loss of human life, bodily injury or serious damage to property ("Specific Applications"), please consult with the ROHM sales representative in advance. Unless otherwise agreed in writing by ROHM in advance, ROHM shall not be in any way responsible or liable for any damages, expenses or losses incurred by you or third parties arising from the use of any ROHM's Products for Specific Applications.

(Note1) Medical Equipment Classification of the Specific Applications

JAPAN	USA	EU	CHINA
CLASS III	CLASS III	CLASS II b	CLASS III
CLASS IV		CLASS III	

- ROHM designs and manufactures its Products subject to strict quality control system. However, semiconductor products can fail or malfunction at a certain rate. Please be sure to implement, at your own responsibilities, adequate safety measures including but not limited to fail-safe design against the physical injury, damage to any property, which a failure or malfunction of our Products may cause. The following are examples of safety measures:
 - Installation of protection circuits or other protective devices to improve system safety
 - Installation of redundant circuits to reduce the impact of single or multiple circuit failure
- Our Products are designed and manufactured for use under standard conditions and not under any special or extraordinary environments or conditions, as exemplified below. Accordingly, ROHM shall not be in any way responsible or liable for any damages, expenses or losses arising from the use of any ROHM's Products under any special or extraordinary environments or conditions. If you intend to use our Products under any special or extraordinary environments or conditions (as exemplified below), your independent verification and confirmation of product performance, reliability, etc. prior to use, must be necessary:
 - Use of our Products in any types of liquid, including water, oils, chemicals, and organic solvents
 - Use of our Products outdoors or in places where the Products are exposed to direct sunlight or dust
 - Use of our Products in places where the Products are exposed to sea wind or corrosive gases, including Cl₂, H₂S, NH₃, SO₂, and NO₂
 - Use of our Products in places where the Products are exposed to static electricity or electromagnetic waves
 - Use of our Products in proximity to heat-producing components, plastic cords, or other flammable items
 - Sealing or coating our Products with resin or other coating materials
 - Use of our Products without cleaning residue of flux (even if you use no-clean type fluxes, cleaning residue of flux is recommended); or Washing our Products by using water or water-soluble cleaning agents for cleaning residue after soldering
 - Use of the Products in places subject to dew condensation
- The Products are not subject to radiation-proof design.
- Please verify and confirm characteristics of the final or mounted products in using the Products.
- In particular, if a transient load (a large amount of load applied in a short period of time, such as pulse. is applied, confirmation of performance characteristics after on-board mounting is strongly recommended. Avoid applying power exceeding normal rated power; exceeding the power rating under steady-state loading condition may negatively affect product performance and reliability.
- De-rate Power Dissipation depending on ambient temperature. When used in sealed area, confirm that it is the use in the range that does not exceed the maximum junction temperature.
- Confirm that operation temperature is within the specified range described in the product specification.
- ROHM shall not be in any way responsible or liable for failure induced under deviant condition from what is defined in this document.

Precaution for Mounting / Circuit board design

- When a highly active halogenous (chlorine, bromine, etc.) flux is used, the residue of flux may negatively affect product performance and reliability.
- In principle, the reflow soldering method must be used on a surface-mount products, the flow soldering method must be used on a through hole mount products. If the flow soldering method is preferred on a surface-mount products, please consult with the ROHM representative in advance.

For details, please refer to ROHM Mounting specification

Precautions Regarding Application Examples and External Circuits

1. If change is made to the constant of an external circuit, please allow a sufficient margin considering variations of the characteristics of the Products and external components, including transient characteristics, as well as static characteristics.
2. You agree that application notes, reference designs, and associated data and information contained in this document are presented only as guidance for Products use. Therefore, in case you use such information, you are solely responsible for it and you must exercise your own independent verification and judgment in the use of such information contained in this document. ROHM shall not be in any way responsible or liable for any damages, expenses or losses incurred by you or third parties arising from the use of such information.

Precaution for Electrostatic

This Product is electrostatic sensitive product, which may be damaged due to electrostatic discharge. Please take proper caution in your manufacturing process and storage so that voltage exceeding the Products maximum rating will not be applied to Products. Please take special care under dry condition (e.g. Grounding of human body / equipment / solder iron, isolation from charged objects, setting of Ionizer, friction prevention and temperature / humidity control).

Precaution for Storage / Transportation

1. Product performance and soldered connections may deteriorate if the Products are stored in the places where:
 - [a] the Products are exposed to sea winds or corrosive gases, including Cl₂, H₂S, NH₃, SO₂, and NO₂
 - [b] the temperature or humidity exceeds those recommended by ROHM
 - [c] the Products are exposed to direct sunshine or condensation
 - [d] the Products are exposed to high Electrostatic
2. Even under ROHM recommended storage condition, solderability of products out of recommended storage time period may be degraded. It is strongly recommended to confirm solderability before using Products of which storage time is exceeding the recommended storage time period.
3. Store / transport cartons in the correct direction, which is indicated on a carton with a symbol. Otherwise bent leads may occur due to excessive stress applied when dropping of a carton.
4. Use Products within the specified time after opening a humidity barrier bag. Baking is required before using Products of which storage time is exceeding the recommended storage time period.

Precaution for Product Label

A two-dimensional barcode printed on ROHM Products label is for ROHM's internal use only.

Precaution for Disposition

When disposing Products please dispose them properly using an authorized industry waste company.

Precaution for Foreign Exchange and Foreign Trade act

Since concerned goods might be fallen under listed items of export control prescribed by Foreign exchange and Foreign trade act, please consult with ROHM in case of export.

Precaution Regarding Intellectual Property Rights

1. All information and data including but not limited to application example contained in this document is for reference only. ROHM does not warrant that foregoing information or data will not infringe any intellectual property rights or any other rights of any third party regarding such information or data.
2. ROHM shall not have any obligations where the claims, actions or demands arising from the combination of the Products with other articles such as components, circuits, systems or external equipment (including software).
3. No license, expressly or implied, is granted hereby under any intellectual property rights or other rights of ROHM or any third parties with respect to the Products or the information contained in this document. Provided, however, that ROHM will not assert its intellectual property rights or other rights against you or your customers to the extent necessary to manufacture or sell products containing the Products, subject to the terms and conditions herein.

Other Precaution

1. This document may not be reprinted or reproduced, in whole or in part, without prior written consent of ROHM.
2. The Products may not be disassembled, converted, modified, reproduced or otherwise changed without prior written consent of ROHM.
3. In no event shall you use in any way whatsoever the Products and the related technical information contained in the Products or this document for any military purposes, including but not limited to, the development of mass-destruction weapons.
4. The proper names of companies or products described in this document are trademarks or registered trademarks of ROHM, its affiliated companies or third parties.

General Precaution

1. Before you use our Products, you are requested to carefully read this document and fully understand its contents. ROHM shall not be in any way responsible or liable for failure, malfunction or accident arising from the use of any ROHM's Products against warning, caution or note contained in this document.
2. All information contained in this document is current as of the issuing date and subject to change without any prior notice. Before purchasing or using ROHM's Products, please confirm the latest information with a ROHM sales representative.
3. The information contained in this document is provided on an "as is" basis and ROHM does not warrant that all information contained in this document is accurate and/or error-free. ROHM shall not be in any way responsible or liable for any damages, expenses or losses incurred by you or third parties resulting from inaccuracy or errors of or concerning such information.

Mouser Electronics

Authorized Distributor

Click to View Pricing, Inventory, Delivery & Lifecycle Information:

[ROHM Semiconductor:](#)

[BD6346FV-E2](#)

Компания «Life Electronics» занимается поставками электронных компонентов импортного и отечественного производства от производителей и со складов крупных дистрибьюторов Европы, Америки и Азии.

С конца 2013 года компания активно расширяет линейку поставок компонентов по направлению коаксиальный кабель, кварцевые генераторы и конденсаторы (керамические, пленочные, электролитические), за счёт заключения дистрибьюторских договоров

Мы предлагаем:

- Конкурентоспособные цены и скидки постоянным клиентам.
- Специальные условия для постоянных клиентов.
- Подбор аналогов.
- Поставку компонентов в любых объемах, удовлетворяющих вашим потребностям.
- Приемлемые сроки поставки, возможна ускоренная поставка.
- Доставку товара в любую точку России и стран СНГ.
- Комплексную поставку.
- Работу по проектам и поставку образцов.
- Формирование склада под заказчика.
- Сертификаты соответствия на поставляемую продукцию (по желанию клиента).
- Тестирование поставляемой продукции.
- Поставку компонентов, требующих военную и космическую приемку.
- Входной контроль качества.
- Наличие сертификата ISO.

В составе нашей компании организован Конструкторский отдел, призванный помогать разработчикам, и инженерам.

Конструкторский отдел помогает осуществить:

- Регистрацию проекта у производителя компонентов.
- Техническую поддержку проекта.
- Защиту от снятия компонента с производства.
- Оценку стоимости проекта по компонентам.
- Изготовление тестовой платы монтаж и пусконаладочные работы.



Тел: +7 (812) 336 43 04 (многоканальный)

Email: org@lifeelectronics.ru