

Discrete Output Light Grid in Robust Aluminum Housing

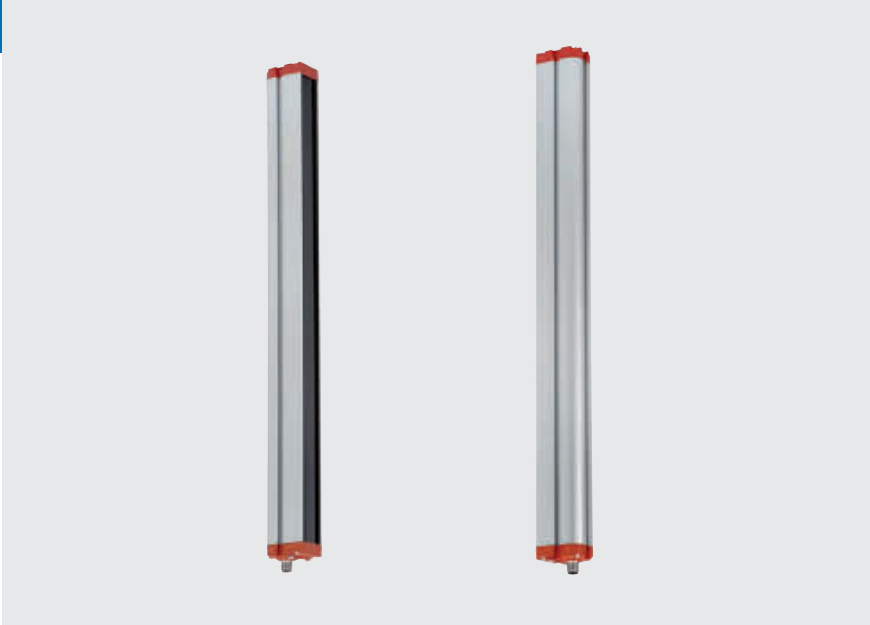

F3ET2

The F3ET2 light grids provide reliable area monitoring in robust housing. The M12, 5-pin connectors and optical synchronization between transmitter and receiver allow for fast and simple installation without special requirements.

- Optical synchronization for reliable operation without additional wiring
- Robust aluminum housing
- NPN/PNP and Light-on / Dark-on selectable
- Brackets included with Light Grids

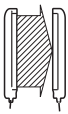

Ordering Information

Sensor Type	Detection Area (mm)	Pitch	Sensing Distance	Beams	Connection Method	Output*	Model
Throughbeam 	150	5 mm	3 m	30	 5 pin	PNP/NPN	F3ET2-005-150
		18 mm	15 m	8			F3ET2-018-150
	300	5 mm	3 m	60			F3ET2-005-300
		18 mm	15 m	16			F3ET2-018-300
	450	5 mm	3 m	90			F3ET2-005-450
		18 mm	15 m	24			F3ET2-018-450
	600	5 mm	3 m	120			F3ET2-005-600
		18 mm	15 m	32			F3ET2-018-600
	900	5 mm	3 m	180			F3ET2-005-900
		18 mm	15 m	48			F3ET2-018-900
	1200	5 mm	3 m	240			F3ET2-005-1200
		18 mm	15 m	64			F3ET2-018-1200
	1500	5 mm	3 m	300			F3ET2-005-1500
		18 mm	15 m	80			F3ET2-018-1500
	1800	5 mm	3 m	360			F3ET2-005-1800
		18 mm	15 m	96			F3ET2-005-1800
2100	18 mm	15 m	112	F3ET2-018-2100			

* Light-ON / Dark-ON selectable

Rating/Specifications

Item	Through-beam	
	F3ET2-005_	F3ET2-018_
Sensing distance	0 to 3 m	0 to 15 m
Vertical detection area	0 to: 150, 300, 450, 600, 900, 1200, 1500, 1800 mm	0 to: 150, 300, 450, 600, 900, 1200, 1500, 1800, 2100 mm
Minimum detectable object size	10 mm	30 mm
Beam axis pitch	5 mm	18 mm
Response time	4 ms + 80 μs × number of beams	
Power-on delay	1 s max	
Light source (wavelength)	Infrared LED (880 nm)	
Power supply voltage	24 VDC ±20%	
Current consumption	150 mA max	
Ambient temperature	-10 to 55°C	
Storage temperature	-25 to 70°C	
Degree of protection	IEC 60529 IP65	
Protective circuits	Reverse polarity protection, output short-circuit protection	
Material	Case	Aluminum
	Cover	Polycarbonate

Cable connectors

For pin arrangement and wire connection refer to Output Circuits.

Type	Features	Material		Model	
		Nut	Cable	Straight	Angled
M12	5 wires	CuZn	PVC 2 m	XS2F-M12PVC5S2M	XS2F-M12PVC5A2M
			PUR 2 m	XS2F-M12PUR5S2M	XS2F-M12PUR5A2M
			PVC 5 m	XS2F-M12PVC5S5M	XS2F-M12PVC5A5M
			PUR 5 m	XS2F-M12PUR5S5M	XS2F-M12PUR5A5M

Output circuits

Please connect the light grid as described below:

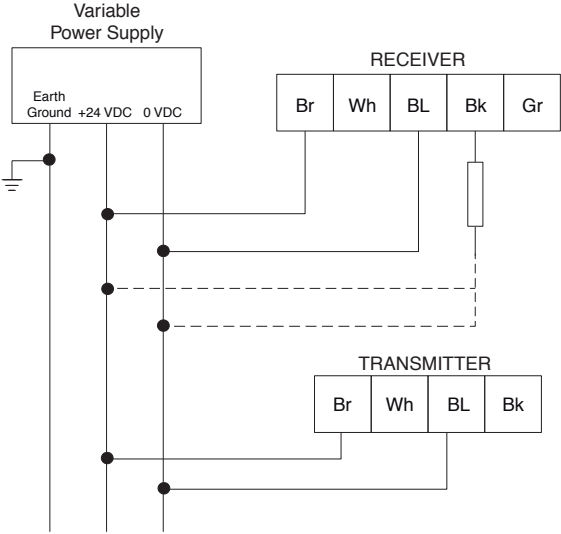

Connector PIN assignment - Receiver

Type	Internal wiring	Pin	Color	Signal name
M12 n4 pole		1	Brown	+Vs
		2	White	not used
		3	Blue	0V
		4	Black	PNP/NPN output
		5	Gray	not used

Connector PIN assignment - Transmitter

Type	Internal wiring	Pin	Color	Signal name
M12 n4 pole		1	Brown	+Vs
		2	White	not used
		3	Blue	0V
		4	Black	Not used

Dimensions

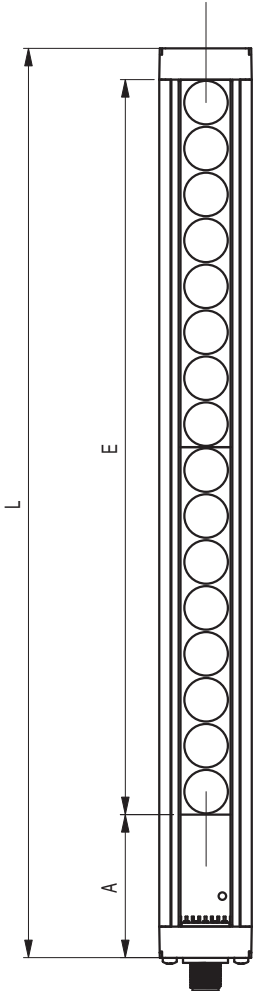

- L: Total length
- E: Detection zone
- A: Dead zone without detection capability

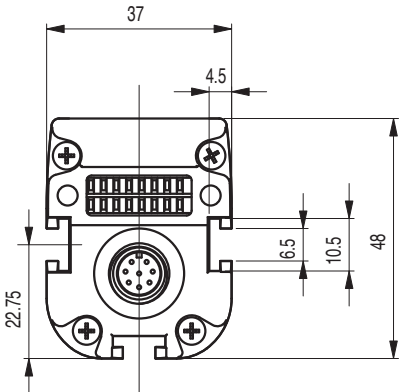

All dimensions shown are in mm

Model	Detection zone E (mm)	Total length L (mm)
F3ET2-005-150	159	218
F3ET2-018-150	147	217
F3ET2-005-300	318	277
F3ET2-018-300	294	364
F3ET2-005-450	477	536
F3ET2-018-450	441	511
F3ET2-005-600	636	695
F3ET2-018-600	588	658
F3ET2-005-900	954	1013
F3ET2-018-900	882	952
F3ET2-005-1200	1272	1331
F3ET2-018-1200	1176	1246
F3ET2-005-1500	1590	1649
F3ET2-018-1500	1470	1540
F3ET2-005-1800	1908	1967
F3ET2-018-1800	1764	1834
F3ET2-018-2100	2058	2128

Operation

The F3ET light grid features optical synchronization. This function is provided by the upper beam located on the opposite side of the connector (see illustration on the right). During operation this beam must always be kept free (unblocked). Otherwise it will result in a longer response frequency of the light grid.

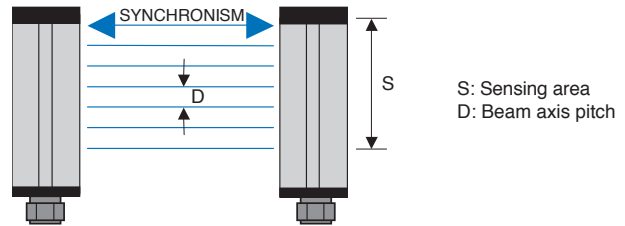

Indicator LEDs

For functions of indicator LEDs please refer to the tables below:

Status of Receiver is displayed by 5 LEDs:

Disposition of indicator	Name of indicator	Color
	POWER	Green
	RUN	Yellow
	FREE	Green
	BREAK	Red
	STATUS	Yellow

Status of Transmitter is displayed by 5 LEDs:

Disposition of indicator	Name of indicator	Color
	POWER	Green
	STATUS 1	Yellow
	RANGE	Green
	Not used	
	STATUS 2	Yellow

Selector Switches

Operation mode and distance setting can be changed by selector switches. To access selector switches, unscrew the end cap of the receiver unit:

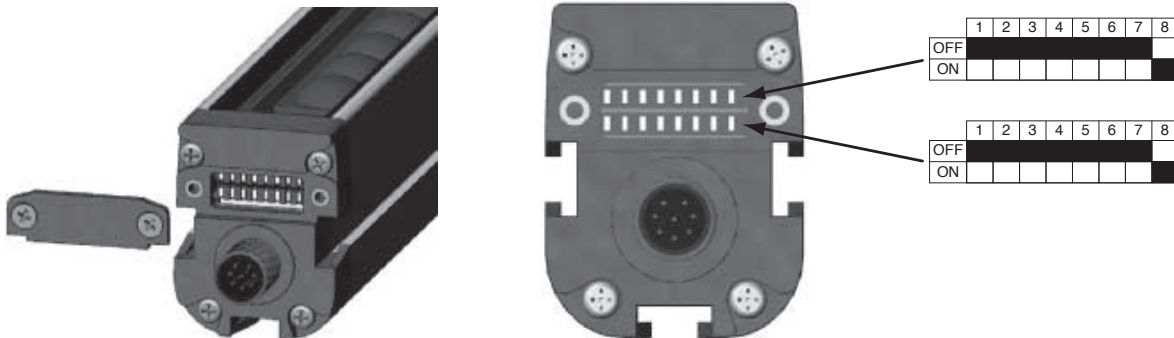

Transmitter

Dip-SW	Status	Function
1, 2, 3, 4, 7, 8	OFF	Not USED
	ON	Not USED
5	OFF	FAR (Default)
	ON	NEAR

Receiver

Dip-SW	Status	Function
1, 4, 5, 7, 8	OFF	Not USED
	ON	Not USED
2	OFF	PNP operation (Default)
	ON	NPN operation
3	OFF	Dark on (Default)
	ON	Light on

Note: Selector setting must only be carried out when the receiver is NOT connected to the power supply. There are two lines of dip switches in each transmitter and receiver. The settings must be done for both lines.

Mounting

Mounting accessories

The F3ET2 system is mechanically installed by using the T-slots on the two sides or the back-side of the housing.

Use the movable bolts, washers, spacers and nuts to attach the mounting brackets as shown in the picture

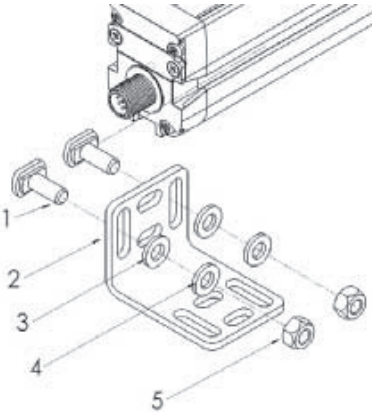

ID	Description
1	M6 bolt
2	bracket
3	M6 washer
4	M6 spacer
5	M6 nut

Note: Shipments contain a different quantity of brackets, depending on the length of the light grid. Longer light grids contain a higher number of brackets, following the rule of one bracket every 400 mm.

Additional mounting rigidity

It is recommended that the distance between the mounting brackets is 400 mm or less for optimum performance of the F3ET2 system.

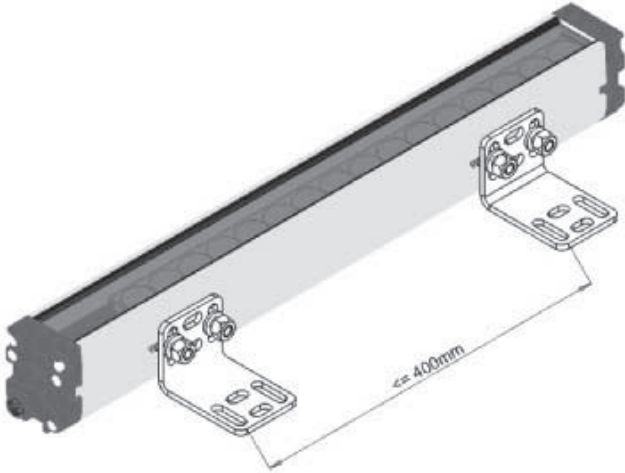

Mechanical Mounting

Please mount the light grids in proper alignment as shown in the pictures below by using the brackets provided with the light grids.

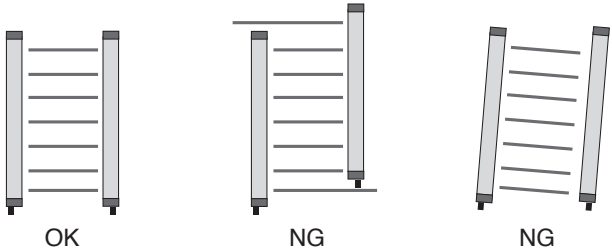

If several light grids are installed close to each other, interference of the light grids must be avoided. In this case the assembly should be carried out as follows:

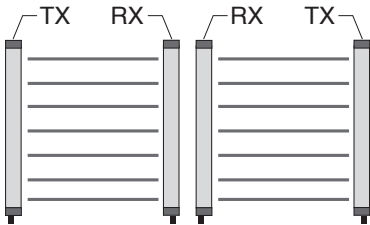

Precautions

⚠ WARNING

The F3ET multi-beam photoelectric sensor is not a safety component for ensuring the safety of people which is defined in EC directive (2006/42/EC) or by any other regulations or standards.

Power Supply Voltage and Output Load Power Supply Voltage

Do not connect an AC power supply to the Sensor. If AC power (100 VAC or more) is supplied to the Sensor, it may be damaged, explode or burn. Make sure that the power supply to the Sensor is within the rated voltage range. If a voltage exceeding the rated voltage range is supplied to the Sensor, it may explode or burn.

Operating Environment

Do not use the sensor in locations with explosive or flammable gas. Make sure that the product is operated in accordance with IP65 standards.

Do not subject the sensor to excessive shock when mounting.

When you use the sensor in the vicinity of an inverter motor, be sure to connect the protective earth ground wire of the motor to earth. Failure to ground the motor may result in malfunction of the sensor.

Mounting the Sensor

Do not strike the sensor with a hammer or any other tool during the installation of the Sensor.

Cleaning

Never use paint thinners or other organic solvents to clean the surface of the product

M12 Connector

Always turn OFF the power supply to the sensor before connecting or disconnecting the metal connector. Hold the connector cover to connect or disconnect it.

Secure the connector cover by hand. Do not use pliers; otherwise the connector may be damaged.

If the connector is not connected securely, it may be disconnected by vibration or the proper degree of protection of the sensor may not be maintained.

OMRON AUTOMATION AND SAFETY • THE AMERICAS HEADQUARTERS • Schaumburg, IL USA • 847.843.7900 • 800.556.6766 • www.omron247.com

OMRON CANADA, INC. • HEAD OFFICE

Toronto, ON, Canada • 416.286.6465 • 866.986.6766 • www.omron247.com

OMRON ELECTRONICS DE MEXICO • HEAD OFFICE

México DF • 52.55.59.01.43.00 • 001.800.556.6766 • mela@omron.com

OMRON ELECTRONICS DE MEXICO • SALES OFFICE

Apodaca, N.L. • 52.81.11.56.99.20 • 001.800.556.6766 • mela@omron.com

OMRON ELETRÔNICA DO BRASIL LTDA • HEAD OFFICE

São Paulo, SP, Brasil • 55.11.2101.6300 • www.omron.com.br

OMRON ARGENTINA • SALES OFFICE

Cono Sur • 54.11.4783.5300

OMRON CHILE • SALES OFFICE

Santiago • 56.9.9917.3920

OTHER OMRON LATIN AMERICA SALES

54.11.4783.5300

OMRON EUROPE B.V. • Wegalaan 67-69, NL-2132 JD, Hoofddorp, The Netherlands. • Tel: +31 (0) 23 568 13 00 • Fax: +31 (0) 23 568 13 88 • www.industrial.omron.eu

Компания «Life Electronics» занимается поставками электронных компонентов импортного и отечественного производства от производителей и со складов крупных дистрибьюторов Европы, Америки и Азии.

С конца 2013 года компания активно расширяет линейку поставок компонентов по направлению коаксиальный кабель, кварцевые генераторы и конденсаторы (керамические, пленочные, электролитические), за счёт заключения дистрибьюторских договоров

Мы предлагаем:

- Конкурентоспособные цены и скидки постоянным клиентам.
- Специальные условия для постоянных клиентов.
- Подбор аналогов.
- Поставку компонентов в любых объемах, удовлетворяющих вашим потребностям.
- Приемлемые сроки поставки, возможна ускоренная поставка.
- Доставку товара в любую точку России и стран СНГ.
- Комплексную поставку.
- Работу по проектам и поставку образцов.
- Формирование склада под заказчика.
- Сертификаты соответствия на поставляемую продукцию (по желанию клиента).
- Тестирование поставляемой продукции.
- Поставку компонентов, требующих военную и космическую приемку.
- Входной контроль качества.
- Наличие сертификата ISO.

В составе нашей компании организован Конструкторский отдел, призванный помогать разработчикам, и инженерам.

Конструкторский отдел помогает осуществить:

- Регистрацию проекта у производителя компонентов.
- Техническую поддержку проекта.
- Защиту от снятия компонента с производства.
- Оценку стоимости проекта по компонентам.
- Изготовление тестовой платы монтаж и пусконаладочные работы.



Тел: +7 (812) 336 43 04 (многоканальный)
Email: org@lifeelectronics.ru