

SZP6SMB Series



Agency Approvals

Agency	Agency File Number
	E128662

Maximum Ratings and Thermal Characteristics

Parameter	Symbol	Value	Unit
Peak Power Dissipation (Note 1) @ $T_L = 25^\circ\text{C}$, Pulse Width = 1 ms	P_{PK}	600	W
DC Power Dissipation @ $T_L = 75^\circ\text{C}$ Measured Zero Lead Length (Note 2) Derate Above 75°C	P_D	3.0 40	W $\text{mW}/^\circ\text{C}$
Thermal Resistance from Junction-to-Lead	$R_{\theta JL}$	25	$^\circ\text{C}/\text{W}$
DC Power Dissipation (Note 3) @ $T_A = 25^\circ\text{C}$ Derate Above 25°C	P_D	0.55 4.4	W $\text{mW}/^\circ\text{C}$
Thermal Resistance from Junction-to-Ambient	$R_{\theta JA}$	226	$^\circ\text{C}/\text{W}$
Forward Surge Current (Note 4) @ $T_A = 25^\circ\text{C}$	I_{FSM}	100	A
Operating and Storage Temperature Range	T_J, T_{stg}	-65 to +150	$^\circ\text{C}$

Stresses exceeding those listed in the Maximum Ratings table may damage the component. If any of these limits are exceeded, device functionality should not be assumed, damage may occur and reliability may be affected.

- 10/1000 μs , non-repetitive.
- 1" square copper pad, FR-4 board.
- FR-4 board, using Littelfuse minimum recommended footprint
- 1/2 sine wave (or equivalent square wave), PW = 8.3 ms, duty cycle = 4 pulses per minute maximum. For Unidirectional only.

Description

The SZP6SMB series is designed to protect voltage sensitive components from high voltage, high energy transients. They have excellent clamping capability, high surge capability, low breakdown impedance and fast response time. The SZP6SMB series is supplied in the Littelfuse exclusive, cost-effective, highly reliable package and is ideally suited for use in communication systems, automotive, numerical controls, process controls, medical equipment, business machines, power supplies and many other industrial/consumer applications.

Features

- Zener Transient Overvoltage Suppressors
- Working Peak Reverse Voltage Range – 5.8 to 171 V (for Uni-directional), 9.4 to 70.1 V (for Bi-directional)
- Standard Breakdown Voltage Range – 6.45 to 210V for Uni-directional , 10.5 to 86.1V for Bi-directional
- Peak Power – 600 W @ 1 ms
- ESD Rating of Class 3 (> 16 kV) per Human Body Model
- Maximum Clamp Voltage @ Peak Pulse Current
- Low Leakage < 5 μA Above 10 V
- Response Time is Typically < 1 ns
- Pb-free means 2nd level interconnect is Pb-free and the terminal finish material is tin(Sn) (IPC/JEDEC J-STD-609A.01)
- SZ Prefix for Automotive and Other Applications Requiring Unique Site and Control Change Requirements; AEC-Q101 Qualified and PPAP Capable

Additional Information



Datasheet



Resources



Samples

Functional Diagram

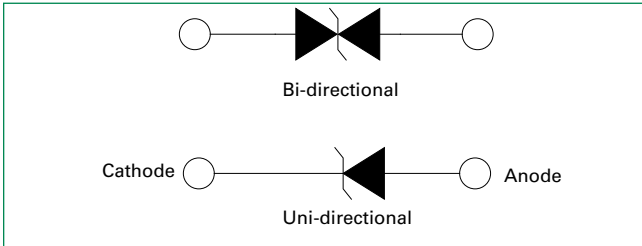

I-V Curve Characteristics ($T_A = 25^\circ\text{C}$ unless otherwise noted, $V_F = 3.5\text{ V Max.}$ @ I_F (Note 5) = 30 A) **For Uni-directional**

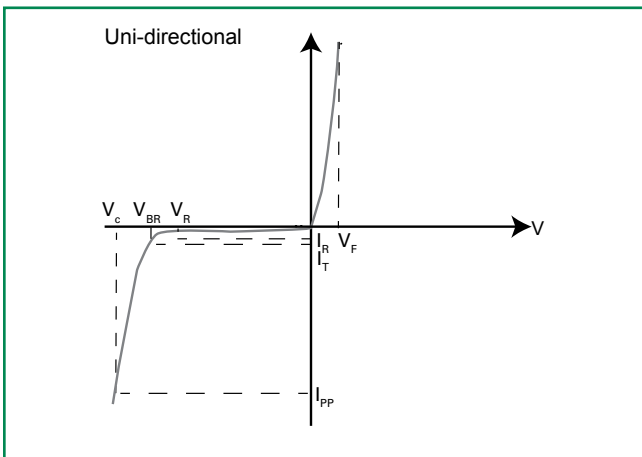

Symbol	Parameter
I_{PP}	Maximum Reverse Peak Pulse Current
V_C	Clamping Voltage @ I_{PP}
V_{RWM}	Working Peak Reverse Voltage
I_R	Maximum Reverse Leakage Current @ V_{RWM}
V_{BR}	Breakdown Voltage @ I_T
I_T	On-State Current
V_F	Forward Voltage @ I_F
I_F	Forward Current

5. 1/2 sine wave (or equivalent square wave), PW = 8.3 ms, non-repetitive duty cycle.

I-V Curve Characteristics ($T_A = 25^\circ\text{C}$ unless otherwise noted) – **For Bi-directional**

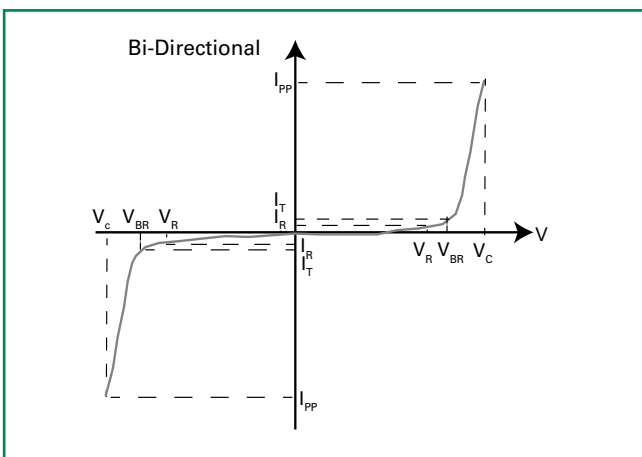

Symbol	Parameter
I_{PP}	Maximum Reverse Peak Pulse Current
V_C	Clamping Voltage @ I_{PP}
V_{RWM}	Working Peak Reverse Voltage
I_R	Maximum Reverse Leakage Current @ V_{RWM}
V_{BR}	Breakdown Voltage @ I_T
I_T	Test Current

Electrical Characteristics - For Unidirectional

Component	Component Marking	Breakdown Voltage						$V_C @ I_{PP}$ (Note 8)		V_{BR}	C_{TYP} (Note 9)
		V_{RWM} (Note 6)	$I_R @ V_{RWM}$	$V_{BR} @ I_T$ (V) (Note 7)			@ I_T	V_C	I_{PP}		
		Volts	μA	MIN	NOM	MAX	mA	Volts	Amps	%/°C	pF
SZP6SMB6.8AT3G	6V8A	5.8	1000	6.45	6.8	7.14	10	10.5	57	0.057	2380
SZP6SMB7.5AT3G	7V5A	6.4	500	7.13	7.51	7.88	10	11.3	53	0.061	2180
SZP6SMB8.2AT3G	8V2A	7.02	200	7.79	8.2	8.61	10	12.1	50	0.065	2015
SZP6SMB9.1AT3G	9V1A	7.78	50	8.65	9.1	9.55	1	13.4	45	0.068	1835
SZP6SMB10AT3G	10A	8.55	10	9.5	10	10.5	1	14.5	41	0.073	1690
SZP6SMB12AT3G	12A	10.2	5	11.4	12	12.6	1	16.7	36	0.078	1435
SZP6SMB13AT3G	13A	11.1	5	12.4	13.05	13.7	1	18.2	33	0.081	1335
SZP6SMB15AT3G	15A	12.8	5	14.3	15.05	15.8	1	21.2	28	0.084	1175
SZP6SMB16AT3G	16A	13.6	5	15.2	16	16.8	1	22.5	27	0.086	1110
SZP6SMB18AT3G	18A	15.3	5	17.1	18	18.9	1	25.2	24	0.088	1000
SZP6SMB20AT3G	20A	17.1	5	19	20	21	1	27.7	22	0.09	910
SZP6SMB22AT3G	22A	18.8	5	20.9	22	23.1	1	30.6	20	0.092	835
SZP6SMB24AT3G	24A	20.5	5	22.8	24	25.2	1	33.2	18	0.094	775
SZP6SMB27AT3G	27A	23.1	5	25.7	27.05	28.4	1	37.5	16	0.096	700
SZP6SMB30AT3G	30A	25.6	5	28.5	30	31.5	1	41.4	14.4	0.097	635
SZP6SMB33AT3G	33A	28.2	5	31.4	33.05	34.7	1	45.7	13.2	0.098	585
SZP6SMB36AT3G	36A	30.8	5	34.2	36	37.8	1	49.9	12	0.099	540
SZP6SMB39AT3G	39A	33.3	5	37.1	39.05	41	1	53.9	11.2	0.1	500
SZP6SMB43AT3G	43A	36.8	5	40.9	43.05	45.2	1	59.3	10.1	0.101	460
SZP6SMB47AT3G	47A	40.2	5	44.7	47.05	49.4	1	64.8	9.3	0.101	425
SZP6SMB51AT3G	51A	43.6	5	48.5	51.05	53.6	1	70.1	8.6	0.102	395
SZP6SMB56AT3G	56A	47.8	5	53.2	56	58.8	1	77	7.8	0.103	365
SZP6SMB62AT3G	62A	53	5	58.9	62	65.1	1	85	7.1	0.104	335
SZP6SMB68AT3G	68A	58.1	5	64.6	68	71.4	1	92	6.5	0.104	305
SZP6SMB75AT3G	75A	64.1	5	71.3	75.05	78.8	1	103	5.8	0.105	280
SZP6SMB91AT3G	91A	77.8	5	86.5	91	95.5	1	125	4.8	0.106	235
SZP6SMB100AT3G	100A	85.5	5	95	100	105	1	137	4.4	0.106	215
SZP6SMB120AT3G	120A	102	5	114	120	126	1	165	3.6	0.107	185
SZP6SMB130AT3G	130A	111	5	124	130.5	137	1	179	3.3	0.107	170
SZP6SMB150AT3G	150A	128	5	143	150.5	158	1	207	2.9	0.108	150
SZP6SMB160AT3G	160A	136	5	152	160	168	1	219	2.7	0.108	140
SZP6SMB180AT3G	180A	154	5	171	180	189	1	246	2.4	0.108	130
SZP6SMB200AT3G	200A	171	5	190	200	210	1	274	2.2	0.108	115

Electrical Characteristics - For Bidirectional

Component	Component Marking	V _{RWM} (Note 5)	I _R @ V _{RWM}	Breakdown Voltage				V _C @ I _{PP} (Note 8)		V _{BR}	C _{Typ.} (Note 9)
				V _{BR} @ I _T (V) (Note 7)			@ I _T	V _C	I _{PP}		
				Volts	μA	MIN	NOM	MAX	mA		
SZP6SMB11CAT3G	11C	9.4	5	10.5	11.05	11.6	1	15.6	38	0.075	865
SZP6SMB12CAT3G	12C	10.2	5	11.4	12	12.6	1	16.7	36	0.078	800
SZP6SMB15CAT3G	15C	12.8	5	14.3	15.05	15.8	1	21.2	28	0.084	645
SZP6SMB16CAT3G	16C	13.6	5	15.2	16	16.8	1	22.5	27	0.086	610
SZP6SMB18CAT3G	18C	15.3	5	17.1	18	18.9	1	25.2	24	0.088	545
SZP6SMB20CAT3G	20C	17.1	5	19	20	21	1	27.7	22	0.09	490
SZP6SMB22CAT3G	22C	18.8	5	20.9	22	23.1	1	30.6	20	0.09	450
SZP6SMB24CAT3G	24C	20.5	5	22.8	24	25.2	1	33.2	18	0.094	415
SZP6SMB27CAT3G	27C	23.1	5	25.7	27.05	28.4	1	37.5	16	0.096	370
SZP6SMB30CAT3G	30C	25.6	5	28.5	30	31.5	1	41.4	14.4	0.097	335
SZP6SMB33CAT3G	33C	28.2	5	31.4	33.05	34.7	1	45.7	13.2	0.098	305
SZP6SMB36CAT3G	36C	30.8	5	34.2	36	37.8	1	49.9	12	0.099	280
SZP6SMB39CAT3G	39C	33.3	5	37.1	39.05	41	1	53.9	11.2	0.1	260
SZP6SMB43CAT3G	43C	36.8	5	40.9	43.05	45.2	1	59.3	10.1	0.101	240
SZP6SMB47CAT3G	47C	40.2	5	44.7	47.05	49.4	1	64.8	9.3	0.101	220
SZP6SMB51CAT3G	51C	43.6	5	48.5	51.05	53.6	1	70.1	8.6	0.102	205
SZP6SMB56CAT3G	56C	47.8	5	53.2	56	58.8	1	77	7.8	0.103	185
SZP6SMB62CAT3G	62C	53	5	58.9	62	65.1	1	85	7.1	0.104	170
SZP6SMB68CAT3G	68C	58.1	5	64.6	68	71.4	1	92	6.5	0.104	155
SZP6SMB82CAT3G	82C	70.1	5	77.9	82	86.1	1	113	5.3	0.105	130

6. A transient suppressor is normally selected according to the working peak reverse voltage (V_{RWM}), which should be equal to or greater than the DC or continuous peak operating voltage level.

7. V_{BR} measured at pulse test current I_T at an ambient temperature of 25°C.

8. Surge current waveform per Figure 2 and derate per Figure 3 of the General Data – 600 Watt at the beginning of this group.

9. Bias Voltage = 0 V, F = 1 MHz, T_J = 25°C

Ratings and Characteristic Curves - For Unidirectional

Figure 1. Pulse Rating Curve

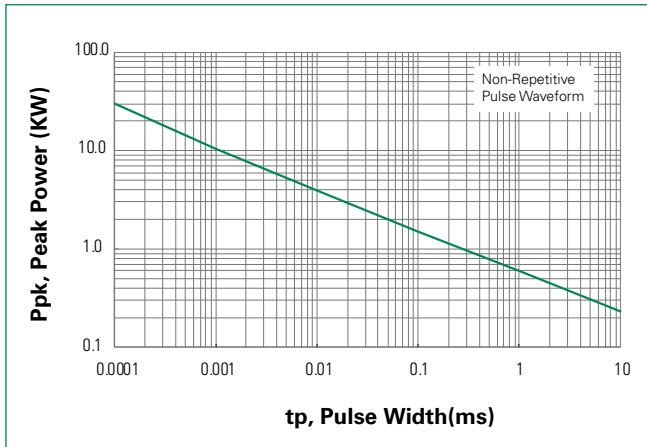

Figure 2. Pulse Waveform

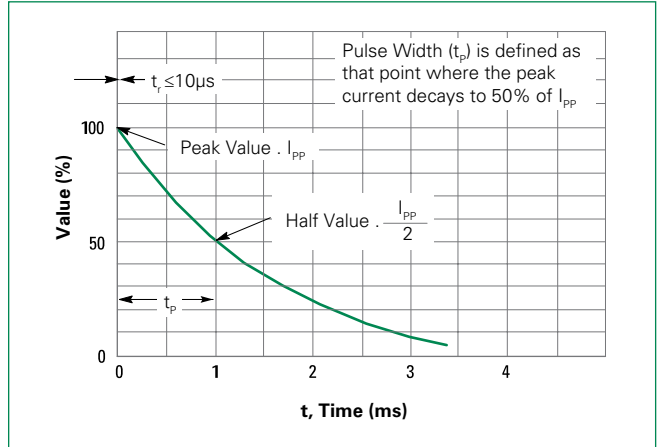

Figure 3. Surge Derating Curve

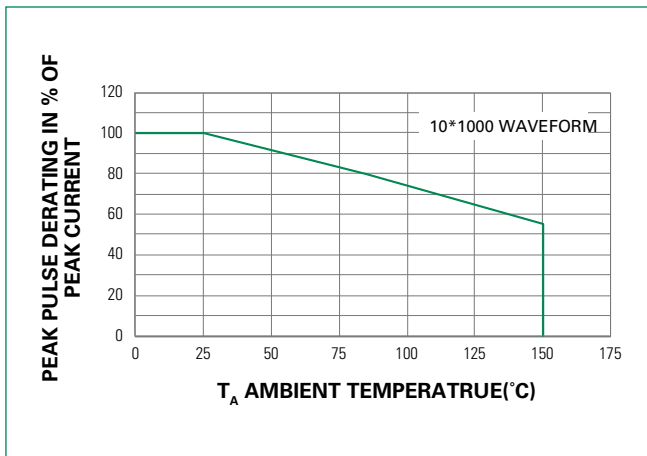

Figure 4. Typical Junction Capacitance vs. Bias Voltage

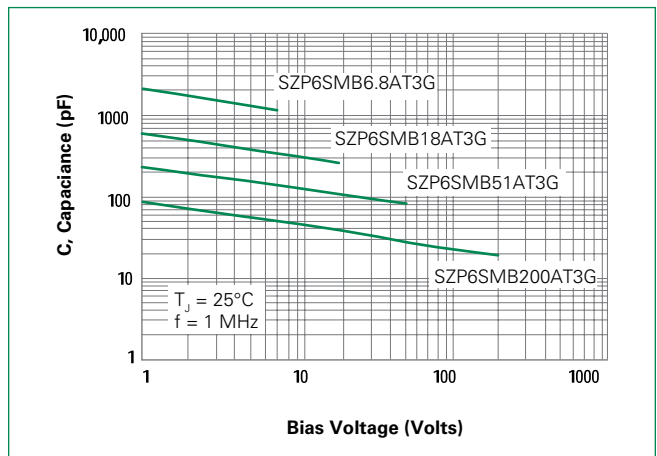

Figure 5. Typical Junction Capacitance vs. Bias Voltage

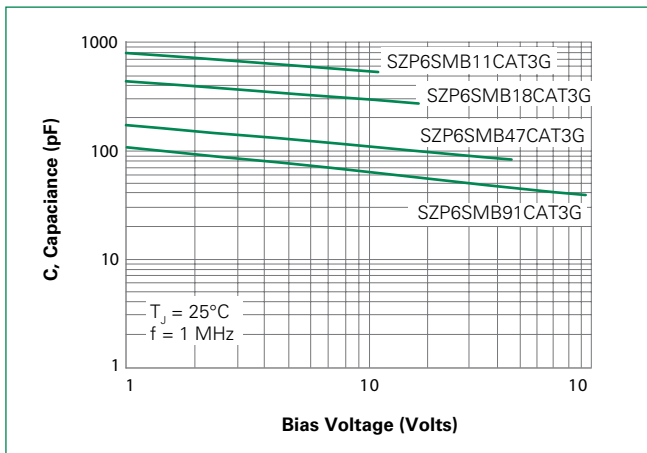
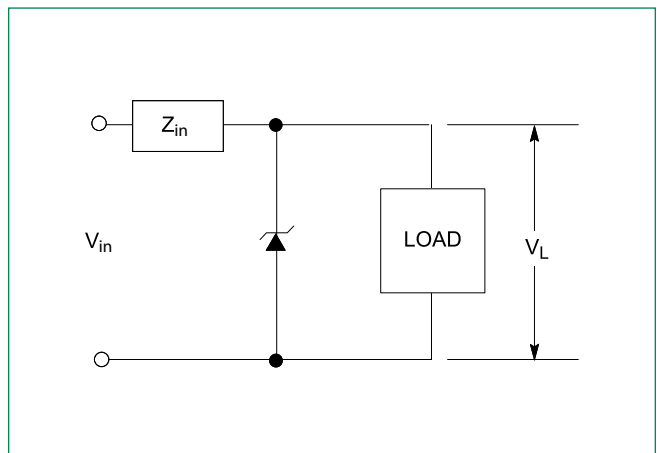
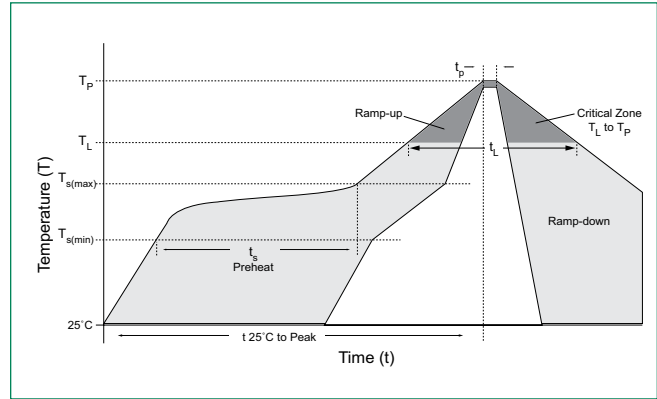

Figure 6. Typical Protection Circuit



Soldering Parameters

Reflow Condition		Lead-free assembly
Pre Heat	- Temperature Min ($T_{s(min)}$)	150°C
	- Temperature Max ($T_{s(max)}$)	200°C
	- Time (min to max) (t_p)	60 – 120 secs
Average ramp up rate (Liquidus Temp (T_L) to peak)		3°C/second max
$T_{s(max)}$ to T_L - Ramp-up Rate		3°C/second max
Reflow	- Temperature (T_L) (Liquidus)	217°C
	- Time (min to max) (t_r)	60 – 150 seconds
Peak Temperature (T_p)		260 ^{+0/-5} °C
Time within 5°C of actual peak Temperature (t_p)		30 seconds max
Ramp-down Rate		6°C/second max
Time 25°C to peak Temperature (T_p)		8 minutes max.
Do not exceed		260°C



Physical Specifications

Weight	0.00326 ounce, 0.1015 grams
Case	JEDEC DO214AA. Void-Free, Transfer-Molded, Thermosetting Plastic Epoxy Meets UL 94V-0
Polarity	Color band denotes cathode for unidirectional components.
Terminal	Matte Tin-plated leads, Solderable per JESD22-B102

Environmental Specifications

High Temp. Storage	JESD22-A103
HTRB	JESD22-A108
Temperature Cycling	JESD22-A104
MSL	JEDEC-J-STD-020, Level 1
H3TRB	JESD22-A101
RSH	JESD22-A111

Dimensions

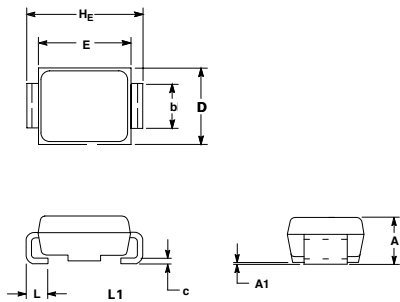

Dim	Inches			Millimeters		
	Min	Nom	Max	Min	Nom	Max
A	0.077	0.091	0.097	1.95	2.30	2.47
A1	0.002	0.004	0.008	0.05	0.10	0.20
b	0.077	0.080	0.087	1.96	2.03	2.20
c	0.006	0.009	0.012	0.15	0.23	0.31
D	0.130	0.140	0.156	3.30	3.56	3.95
E	0.160	0.170	0.181	4.06	4.32	4.60
HE	0.205	0.214	0.220	5.21	5.44	5.60
L	0.030	0.040	0.063	0.76	1.02	1.60
L1	0.51 REF			0.020 REF		

Soldering Footprint

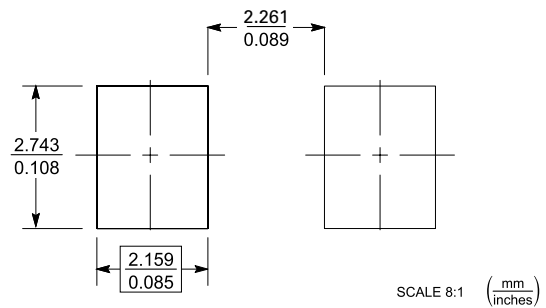

Ordering Information

Device	Package	Shipping
SZP6SMBxxxAT3G	SMB (Pb-Free)	2,500 / Tape & Reel
SZP6SMBxxxCAT3G	SMB (Pb-Free)	2,500 / Tape & Reel

Part Marking System

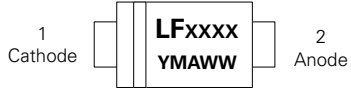

XXXX = Device Code
 Y = Year
 M = Month
 A = Assembly Location
 WW = Lot Code

Part Numbering System

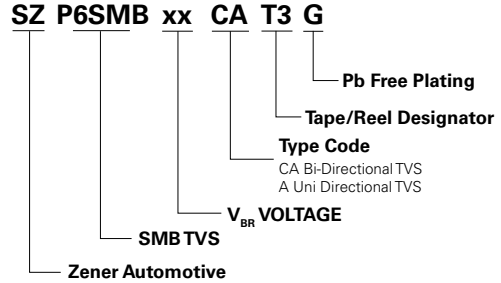

Tape and Reel Specification

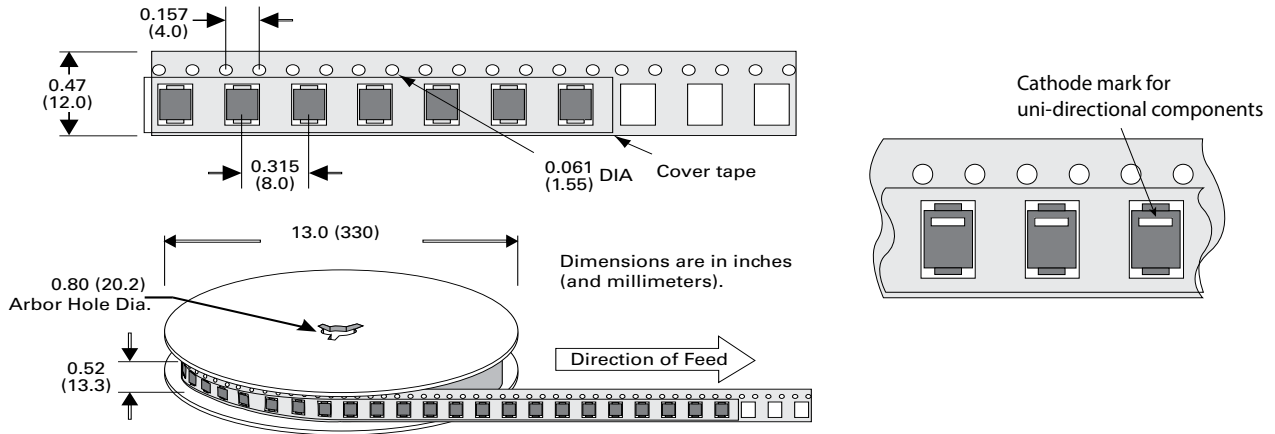

Disclaimer Notice - Information furnished is believed to be accurate and reliable. However, users should independently evaluate the suitability of and test each product selected for their own applications. Littelfuse products are not designed for, and may not be used in, all applications. Read complete Disclaimer Notice at: www.littelfuse.com/disclaimer-electronics.

Компания «Life Electronics» занимается поставками электронных компонентов импортного и отечественного производства от производителей и со складов крупных дистрибьюторов Европы, Америки и Азии.

С конца 2013 года компания активно расширяет линейку поставок компонентов по направлению коаксиальный кабель, кварцевые генераторы и конденсаторы (керамические, пленочные, электролитические), за счёт заключения дистрибьюторских договоров

Мы предлагаем:

- Конкурентоспособные цены и скидки постоянным клиентам.
- Специальные условия для постоянных клиентов.
- Подбор аналогов.
- Поставку компонентов в любых объемах, удовлетворяющих вашим потребностям.
- Приемлемые сроки поставки, возможна ускоренная поставка.
- Доставку товара в любую точку России и стран СНГ.
- Комплексную поставку.
- Работу по проектам и поставку образцов.
- Формирование склада под заказчика.
- Сертификаты соответствия на поставляемую продукцию (по желанию клиента).
- Тестирование поставляемой продукции.
- Поставку компонентов, требующих военную и космическую приемку.
- Входной контроль качества.
- Наличие сертификата ISO.

В составе нашей компании организован Конструкторский отдел, призванный помогать разработчикам, и инженерам.

Конструкторский отдел помогает осуществить:

- Регистрацию проекта у производителя компонентов.
- Техническую поддержку проекта.
- Защиту от снятия компонента с производства.
- Оценку стоимости проекта по компонентам.
- Изготовление тестовой платы монтаж и пусконаладочные работы.



Тел: +7 (812) 336 43 04 (многоканальный)

Email: org@lifeelectronics.ru