

1-Wire 4Kb EEPROM

General Description

The DS24B33 is a 4096-bit, 1-Wire® EEPROM organized as 16 memory pages of 256 bits each. Data is written to a 32-byte scratchpad, verified, and then copied to the EEPROM memory. The DS24B33 communicates over a single-conductor 1-Wire bus. The communication follows the standard 1-Wire protocol. Each device has its own unalterable and unique 64-bit registration number that is factory programmed into the chip. The registration number is used to address the device in a multidrop 1-Wire net environment. The DS24B33 is software compatible to the DS2433.

Applications

Storage of Calibration Constants
 Board Identification
 Storage of Product Revision Status

Typical Operating Circuit

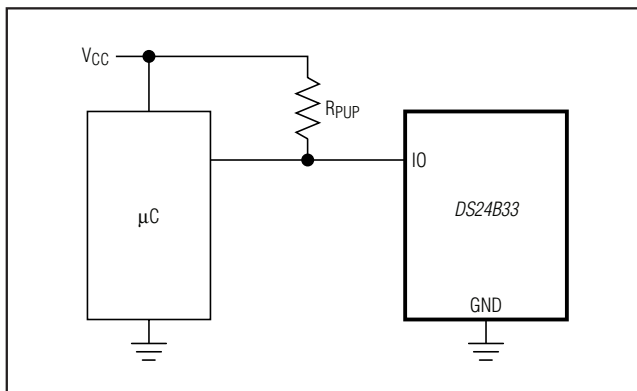

Features

- ◆ 4096 Bits of Nonvolatile EEPROM Partitioned Into Sixteen 256-Bit Pages
- ◆ Read and Write Access is Highly Backward-Compatible to the DS2433
- ◆ 256-Bit Scratchpad with Strict Read/Write Protocols Ensures Integrity of Data Transfer
- ◆ Unique, Factory-Programmed, 64-Bit Registration Number Ensures Error-Free Device Selection and Absolute Part Identity
- ◆ Switchpoint Hysteresis to Optimize Performance in the Presence of Noise
- ◆ Communicates to Host at 15.4kbps or 125kbps Using 1-Wire Protocol
- ◆ Low-Cost Through-Hole and SMD Packages
- ◆ Operating Range: +2.8V to +5.25V, -40°C to +85°C
- ◆ IEC 1000-4-2 Level 4 ESD Protection (±8kV Contact, ±15kV Air, Typical) for IO Pin

Ordering Information

PART	TEMP RANGE	PIN-PACKAGE
DS24B33+	-40°C to +85°C	TO-92
DS24B33+T&R	-40°C to +85°C	TO-92
DS24B33G+T&R	-40°C to +85°C	2 SFN (2.5k pcs)
DS24B33Q+T&R	-40°C to +85°C	6 TDFN-EP* (2.5k pcs)
DS24B33S+	-40°C to +85°C	8 SO (208 mils)
DS24B33S+T&R	-40°C to +85°C	8 SO (208 mils)

Note: The leads of TO-92 packages on tape and reel are formed to approximately 100-mil (2.54mm) spacing. For details, refer to the package outline drawing.

+Denotes a lead(Pb)-free/RoHS-compliant package.

T&R = Tape and reel.

*EP = Exposed pad.

1-Wire is a registered trademark of Maxim Integrated Products, Inc.

For pricing, delivery, and ordering information, please contact Maxim Direct at 1-888-629-4642, or visit Maxim's website at www.maximintegrated.com.

DS24B33

1-Wire 4Kb EEPROM

ABSOLUTE MAXIMUM RATINGS

IO Voltage Range to GND-0.5V to +6V
 IO Sink Current.....20mA
 Operating Temperature Range-40°C to +85°C
 Junction Temperature+150°C
 Storage Temperature Range-55°C to +125°C

Lead Temperature (soldering, 10s).....+300°C
 Soldering Temperature (reflow)
 TO-92+250°C
 All other packages, excluding SFN+260°C

Stresses beyond those listed under "Absolute Maximum Ratings" may cause permanent damage to the device. These are stress ratings only, and functional operation of the device at these or any other conditions beyond those indicated in the operational sections of the specifications is not implied. Exposure to absolute maximum rating conditions for extended periods may affect device reliability.

ELECTRICAL CHARACTERISTICS

(T_A = -40°C to +85°C.) (Note 1)

PARAMETER	SYMBOL	CONDITIONS	MIN	TYP	MAX	UNITS
IO PIN: GENERAL DATA						
1-Wire Pullup Voltage	V _{PUP}	(Notes 2, 3)	2.8		5.25	V
1-Wire Pullup Resistance	R _{PUP}	(Notes 2, 4)	0.3		2.2	kΩ
Input Capacitance	C _{IO}	(Notes 5, 6)		2000		pF
Input Load Current	I _L	IO at V _{PUPMAX}	0.05		5	μA
High-to-Low Switching Threshold	V _{TL}	(Notes 6, 7, 8)	0.5		V _{PUP} - 1.8	V
Input Low Voltage	V _{IL}	(Notes 2, 9)			0.5	V
Low-to-High Switching Threshold	V _{TH}	(Notes 6, 7, 10)	1.0		V _{PUP} - 1.0	V
Switching Hysteresis	V _{HY}	(Notes 6, 7, 11)	0.2		1.7	V
Output Low Voltage	V _{OL}	At 4mA (Note 12)			0.4	V
Recovery Time (Notes 2, 13)	t _{REC}	Standard speed	5			μs
		Overdrive speed	2			
		V _{PUP} ≥ +4.5V	1			
		Directly prior to reset pulse ≤ 640μs	5			
		Directly prior to reset pulse > 640μs	10			
Time-Slot Duration (Notes 2, 14)	t _{SLOT}	Standard speed	65			μs
		Standard speed, V _{PUP} ≥ +4.5V	61			
		Overdrive speed	8			
		Overdrive speed, V _{PUP} ≥ +4.5V	7			
IO PIN: 1-Wire RESET, PRESENCE-DETECT CYCLE						
Reset Low Time (Note 2)	t _{RSTL}	Standard speed, t _{REC} before reset = 10μs	480		960	μs
		Standard speed, t _{REC} before reset = 5μs	480		640	
		Overdrive speed	48		80	
Presence-Detect High Time	t _{PDH}	Standard speed	15		60	μs
		Overdrive speed	2		6	
Presence-Detect Low Time	t _{PDL}	Standard speed	60		240	μs
		Overdrive speed	8		24	
Presence-Detect Sample Time (Notes 2, 15)	t _{MSP}	Standard speed	60		75	μs
		Overdrive speed	6		10	

DS24B33

1-Wire 4Kb EEPROM

ELECTRICAL CHARACTERISTICS (continued)

(T_A = -40°C to +85°C.) (Note 1)

PARAMETER	SYMBOL	CONDITIONS	MIN	TYP	MAX	UNITS
IO PIN: 1-Wire WRITE						
Write-Zero Low Time (Notes 2, 16)	t _{W0L}	Standard speed	60		120	μs
		Overdrive speed	6		16	
Write-One Low Time (Notes 2, 16)	t _{W1L}	Standard speed	5		15	μs
		Overdrive speed	1		2	
IO PIN: 1-Wire READ						
Read Low Time (Notes 2, 17)	t _{RL}	Standard speed	5		15 - δ	μs
		Overdrive speed	1		2 - δ	
Read Sample Time (Notes 2, 17)	t _{MSR}	Standard speed	t _{RL} + δ		15	μs
		Overdrive speed	t _{RL} + δ		2	
EEPROM						
Programming Current	I _{PROG}	(Note 18)			2	mA
Programming Time	t _{PROG}	(Note 19)			5	ms
Write/Erase Cycles (Endurance) (Notes 20, 21)	N _{CY}	At +25°C	200,000			—
		At +85°C (worst case)	50,000			
Data Retention (Notes 22, 23, 24)	t _{DR}	At +85°C (worst case)	40			Years

Note 1: Limits are 100% production tested at T_A = +25°C and/or T_A = +85°C. Limits over the operating temperature range and relevant supply voltage range are guaranteed by design and characterization. Typical values are not guaranteed.

Note 2: System requirement.

Note 3: When operating near the minimum operating voltage (2.8V), a falling edge slew rate of 15V/μs or faster is recommended.

Note 4: Maximum allowable pullup resistance is a function of the number of 1-Wire devices in the system, 1-Wire recovery times, and current requirements during EEPROM programming. The specified value here applies to systems with only one device and with the minimum 1-Wire recovery times. For more heavily loaded systems, an active pullup such as that found in the DS2482-x00 or DS2480B may be required.

Note 5: Capacitance on the data pin could be 250pF when V_{PUP} is first applied. Once the parasite capacitance is charged, it does not affect normal communication.

Note 6: Guaranteed by design, characterization, and/or simulation only. Not production tested.

Note 7: V_{TL}, V_{TH}, and V_{HY} are a function of the internal supply voltage, which is a function of V_{PUP}, R_{PUP}, 1-Wire timing, and capacitive loading on IO. Lower V_{PUP}, higher R_{PUP}, shorter t_{REC}, and heavier capacitive loading all lead to lower values of V_{TL}, V_{TH}, and V_{HY}.

Note 8: Voltage below which, during a falling edge on IO, a logic 0 is detected.

Note 9: The voltage on IO must be less than or equal to V_{ILMAX} at all times while the master is driving IO to a logic 0 level.

Note 10: Voltage above which, during a rising edge on IO, a logic 1 is detected.

Note 11: After V_{TH} is crossed during a rising edge on IO, the voltage on IO must drop by at least V_{HY} to be detected as logic 0.

Note 12: The I-V characteristic is linear for voltages less than +1V.

Note 13: Applies to a single DS24B33 attached to a 1-Wire line.

Note 14: Defines maximum possible bit rate. Equal to 1/(t_{W0LMIN} + t_{RECMIN}).

Note 15: Interval after t_{RSTL} during which a bus master can read a logic 0 on IO if there is a DS24B33 present. The power-up presence detect pulse could be outside this interval but will be complete within 2ms after power-up.

Note 16: ε in Figure 11 represents the time required for the pullup circuitry to pull the voltage on IO up from V_{IL} to V_{TH}. The actual maximum duration for the master to pull the line low is t_{W1LMAX} + t_F - ε and t_{W0LMAX} + t_F - ε, respectively.

Note 17: δ in Figure 11 represents the time required for the pullup circuitry to pull the voltage on IO up from V_{IL} to the input high threshold of the bus master. The actual maximum duration for the master to pull the line low is t_{RLMAX} + t_F.

Note 18: Current drawn from IO during the EEPROM programming interval. The pullup circuit on IO should be such that during the programming interval, the voltage at IO is greater than or equal to V_{PUPMIN}. If V_{PUP} in the system is close to V_{PUPMIN}, then a low-impedance bypass of R_{PUP}, which can be activated during programming, may need to be added.

DS24B33

1-Wire 4Kb EEPROM

ELECTRICAL CHARACTERISTICS (continued)

($T_A = -40^{\circ}\text{C}$ to $+85^{\circ}\text{C}$.) (Note 1)

- Note 19:** The t_{PROG} interval begins after the trailing rising edge on IO for the last time slot of the E/S byte for a valid copy scratch-pad sequence. The interval ends once the device's self-timed EEPROM programming cycle is complete and the current drawn by the device has returned from I_{PROG} to I_L .
- Note 20:** Write-cycle endurance is degraded as T_A increases.
- Note 21:** Not 100% production tested; guaranteed by reliability monitor sampling.
- Note 22:** Data retention is degraded as T_A increases.
- Note 23:** Guaranteed by 100% production test at elevated temperature for a shorter time; equivalence of this production test to data sheet limit at operating temperature range is established by reliability testing.
- Note 24:** EEPROM writes can become nonfunctional after the data-retention time is exceeded. Long-time storage at elevated temperatures is not recommended; the device can lose its write capability after 10 years at $+125^{\circ}\text{C}$ or 40 years at $+85^{\circ}\text{C}$.

Pin Configurations

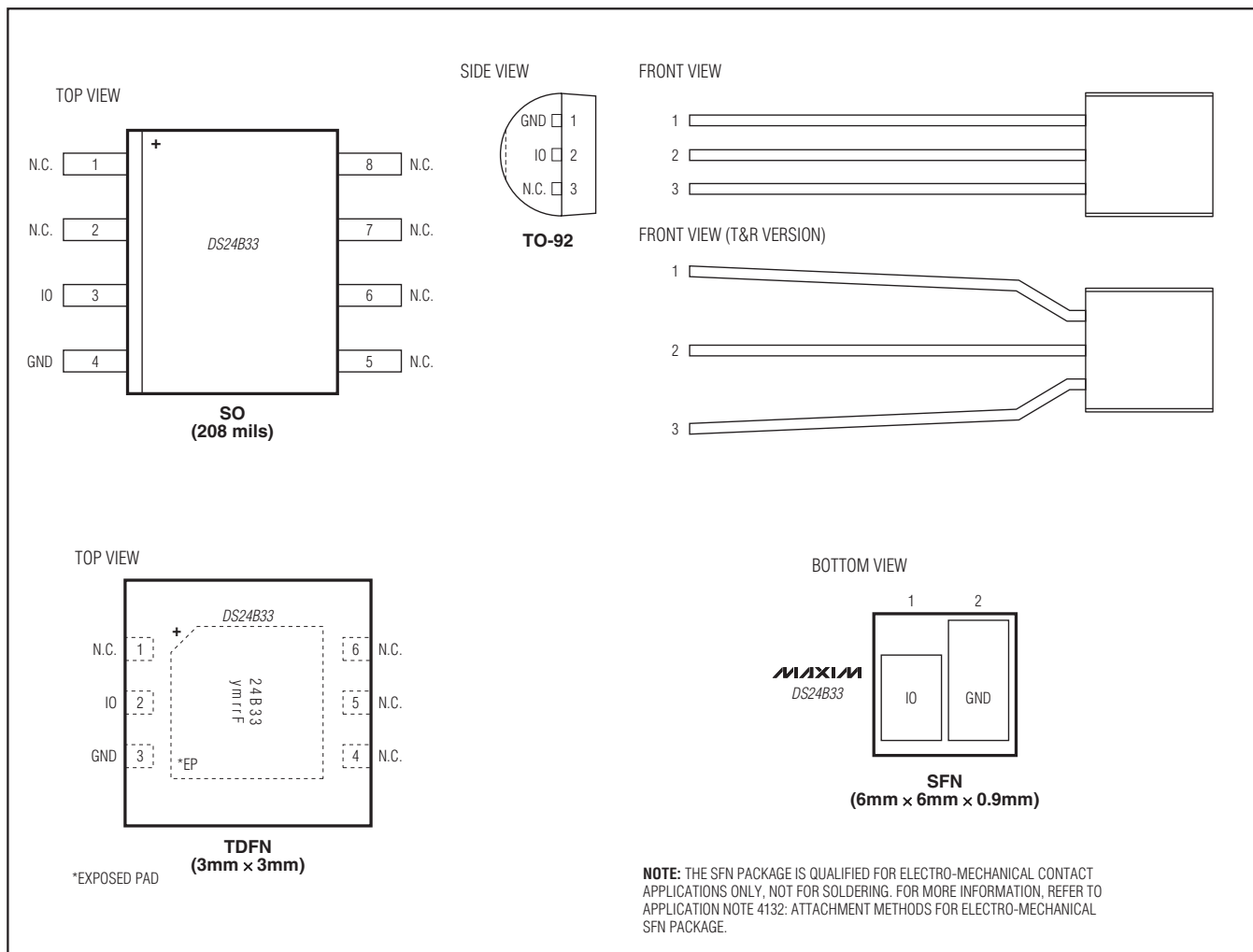

DS24B33

1-Wire 4Kb EEPROM

Pin Description

PIN				NAME	FUNCTION
SFN	TDFN-EP	TO-92	SO		
2	3	1	4	GND	Ground Reference
1	2	2	3	IO	1-Wire Bus Interface. Open-drain pin that requires external pullup
—	1, 4, 5, 6	3	1, 2, 5–8	N.C.	Not Connected
—	—	—	—	EP	Exposed Pad (TDFN only). Solder evenly to the board's ground plane for proper operation. Refer to Application Note 3273: <i>Exposed Pads: A Brief Introduction</i> for additional information.

Detailed Description

The DS24B33 combines 4Kb of data EEPROM with a fully featured 1-Wire interface in a single chip. The memory is organized as 16 pages of 256 bits each. A volatile 256-bit memory page called the scratchpad acts as a buffer when writing data to the EEPROM to ensure data integrity. Data is first written to the scratchpad, from which it can be read back for verification before transferring it to the EEPROM. The operation of the DS24B33 is controlled over the single-conductor 1-Wire bus. Device communication follows the standard 1-Wire protocol. The energy required to read and write the DS24B33 is derived entirely from the 1-Wire communication line. Each DS24B33 has its own unalterable

and unique 64-bit registration number. The registration number guarantees unique identification and is used to address the device in a multidrop 1-Wire net environment. Multiple DS24B33 devices can reside on a common 1-Wire bus and be operated independently of each other. Applications of the DS24B33 include calibration data storage, PCB identification, and storage of product revision status. The DS24B33 provides a high degree of backward compatibility with the DS2433, including having the same family code.

Overview

Figure 1 shows the relationships between the major control and memory sections of the DS24B33. The DS24B33 has four main data components: 64-bit

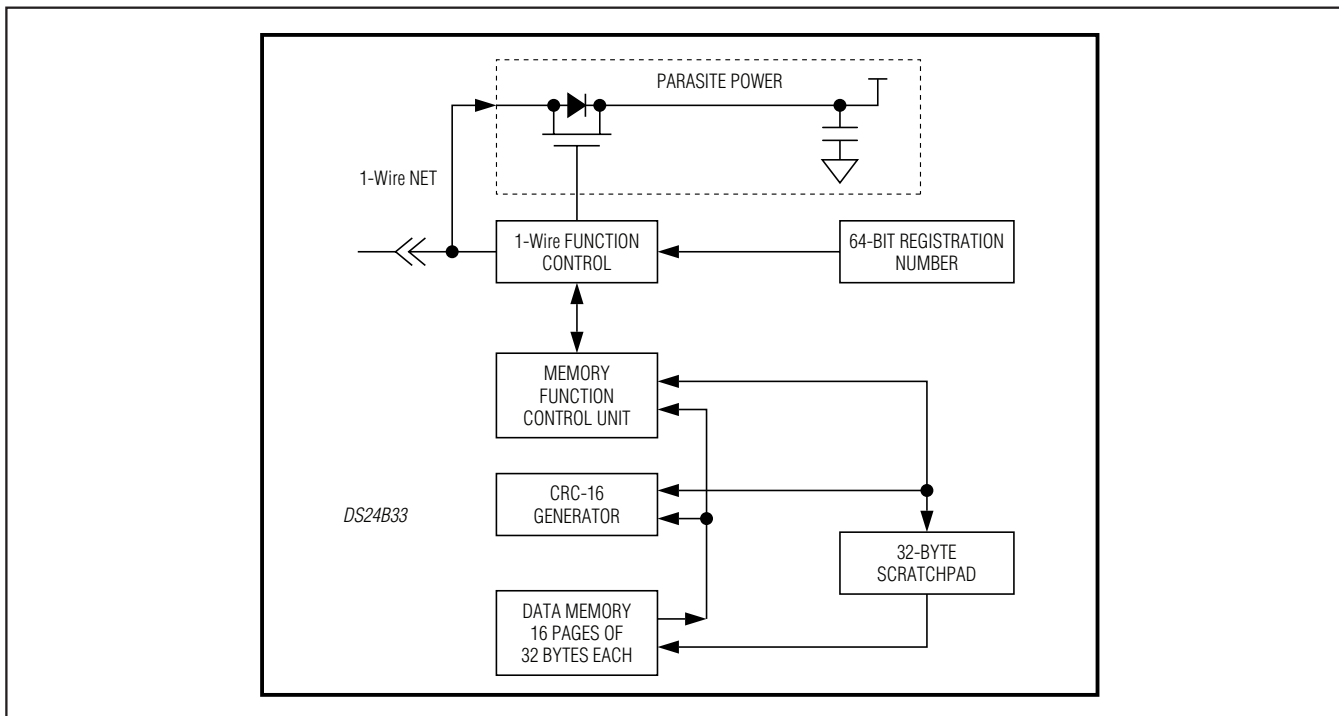

Figure 1. Block Diagram

DS24B33

1-Wire 4Kb EEPROM

registration number, 32-byte scratchpad, sixteen 32-byte pages of EEPROM, and a CRC-16 generator. Figure 2 shows the hierarchical structure of the 1-Wire protocol. The bus master must first provide one of the seven ROM (network) function commands: Read ROM, Match ROM, Search ROM, Skip ROM, Resume, Overdrive-Skip ROM, or Overdrive-Match ROM. Upon completion of an overdrive ROM command byte executed at standard speed, the device enters overdrive mode where all subsequent communication occurs at a higher speed. Figure 9 describes the protocol required for these ROM function commands. After a ROM function command is successfully executed, the memory functions become accessible and the master can provide any one of the four memory function commands. Figure 7 describes the protocol for these commands. **All data is read and written least significant bit (LSB) first.**

Parasite Power

Figure 1 shows the parasite power supply. This circuitry “steals” power whenever the IO input is high. IO provides sufficient power as long as the specified timing and voltage requirements are met.

64-Bit Registration Number

Each DS24B33 contains a unique registration number that is 64 bits long. The first 8 bits are a 1-Wire family code. The next 48 bits are a unique serial number. The last 8 bits are a cyclic redundancy check (CRC) of the first 56 bits. See Figure 3 for details. The 1-Wire CRC is generated using a polynomial generator consisting of a shift register and XOR gates as shown in Figure 4. The polynomial is $X^8 + X^5 + X^4 + 1$. Additional information about the 1-Wire CRC is available in Application Note 27: *Understanding and Using Cyclic Redundancy Checks with Maxim iButton® Products.*

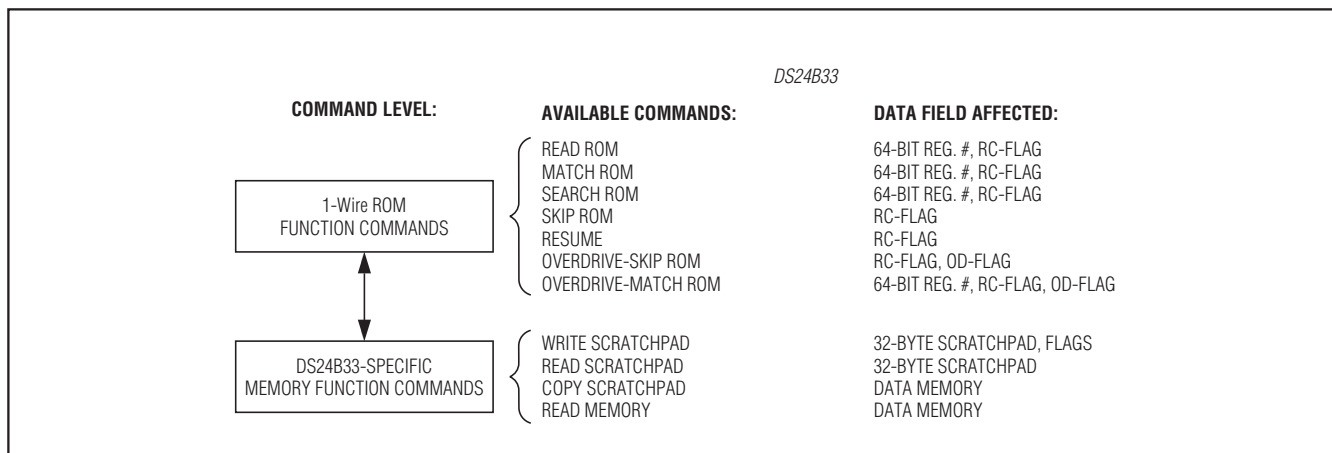

Figure 2. Hierarchical Structure for 1-Wire Protocol

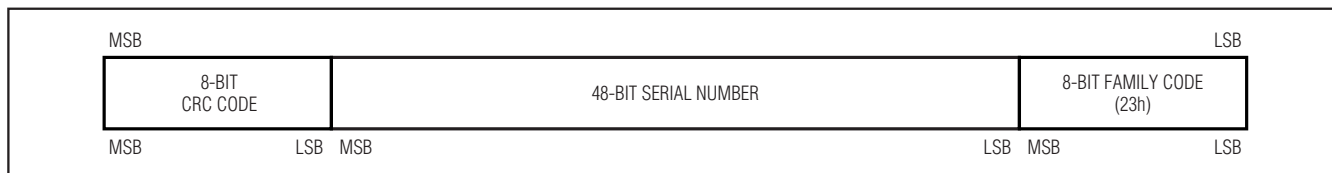

Figure 3. 64-Bit Registration Number

iButton is a registered trademark of Maxim Integrated Products, Inc.

DS24B33

1-Wire 4Kb EEPROM

The shift register bits are initialized to 0. Then, starting with the LSB of the family code, one bit at a time is shifted in. After the 8th bit of the family code has been entered, the serial number is entered. After the last bit of the serial number has been entered, the shift register contains the CRC value. Shifting in the 8 bits of the CRC returns the shift register to all 0s.

Memory

The DS24B33 EEPROM array (Figure 5) consists of 16 pages of 32 bytes each, starting at address 0000h and ending at address 01FFh. In addition to the EEPROM, the device has a 32-byte volatile scratchpad. Writes to the EEPROM array are a two-step process. First, data is written to the scratchpad and then copied into the main array. The user can verify the data in the scratchpad prior to copying.

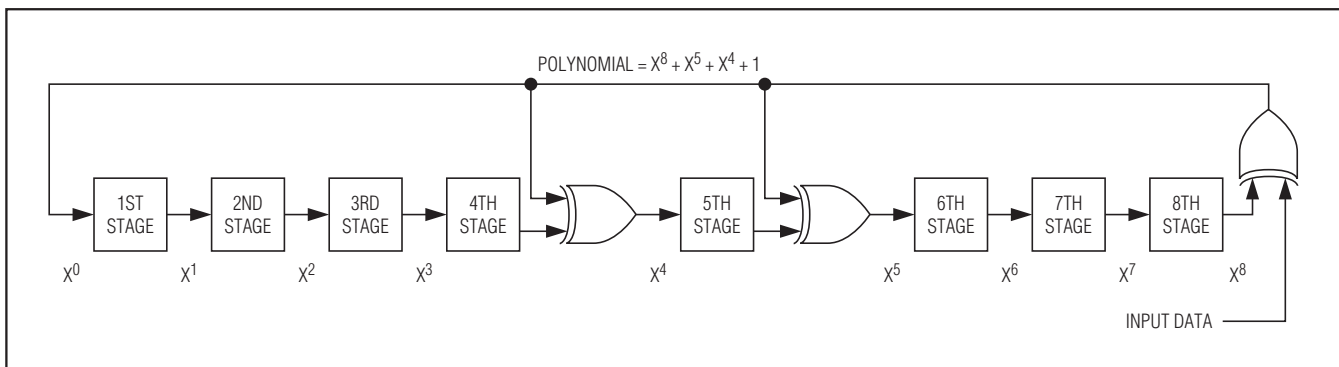

Figure 4. 1-Wire CRC Generator

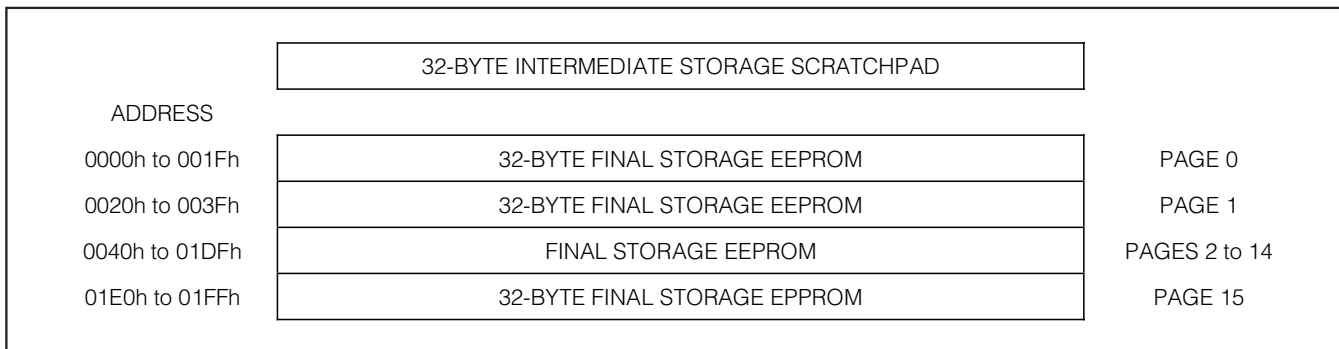

Figure 5. Memory Map

DS24B33

1-Wire 4Kb EEPROM

Memory Access

Address Registers and Transfer Status

The DS24B33 employs three address registers: TA1, TA2, and E/S (Figure 6). Registers TA1 and TA2 must be loaded with the target address to which the data is written or from which data is read. Register E/S is a read-only transfer status register used to verify data integrity with write commands. ES bits E[4:0] are loaded with the incoming T[4:0] on a Write Scratchpad command and increment on each subsequent data byte. This is, in effect, a byte-ending offset counter within the 32-byte scratchpad. Bit 5 of the E/S register, called the partial byte flag (PF), is set if the number of data bits sent by the master is not an integer multiple of 8 or if the data in the scratchpad is not valid due to a loss of power. A valid write to the scratchpad clears the PF bit. Bit 6 has no function; it always reads 0. The highest valued bit of the E/S register, called authorization accepted (AA), is valid only if the PF flag reads 0. If PF is 0 and AA is 1, the data stored in the scratchpad has already been copied to the target memory address. Writing data to the scratchpad clears this flag.

Writing with Verification

To write data to the DS24B33, the scratchpad must be used as intermediate storage. First, the master issues the Write Scratchpad command to specify the desired target address, followed by the data to be written to the scratchpad. Under certain conditions (see the *Write*

Scratchpad [0Fh] section) the master receives an inverted CRC-16 of the command, address, and data at the end of the Write Scratchpad command sequence. Knowing this CRC value, the master can compare it to the value it has calculated itself to decide if the communication was successful and proceed to the Copy Scratchpad command. If the master could not receive the CRC-16, it should send the Read Scratchpad command to verify data integrity. As a preamble to the scratchpad data, the DS24B33 repeats the target address TA1 and TA2 and sends the contents of the E/S register. If the PF flag is set, data did not arrive correctly in the scratchpad or there was a loss of power since data was last written to the scratchpad. The master does not need to continue reading; it can start a new trial to write data to the scratchpad. Similarly, a set AA flag together with a cleared PF flag indicates that the device did not recognize the write command. If everything went correctly, both flags are cleared and the ending offset indicates the address of the last byte written to the scratchpad. Now the master can continue reading and verifying every data byte. After the master has verified the data, it can send the Copy Scratchpad command, for example. This command must be followed exactly by the data of the three address registers TA1, TA2, and E/S. The master should obtain the contents of these registers by reading the scratchpad. As soon as the DS24B33 has received these bytes correctly, it starts copying the scratchpad data to the requested location.

BIT NUMBER	7	6	5	4	3	2	1	0
TARGET ADDRESS (TA1)	T7	T6	T5	T4	T3	T2	T1	T0
TARGET ADDRESS (TA2)	T15	T14	T13	T12	T11	T10	T9	T8
ENDING ADDRESS WITH DATA STATUS (E/S) (READ ONLY)	AA	0	PF	E4	E3	E2	E1	E0

Figure 6. Address Registers

DS24B33

1-Wire 4Kb EEPROM

Memory Function Commands

The *Memory Function Flowchart* (Figure 7) describes the protocols necessary for accessing the memory of the DS24B33. The target address registers TA1 and TA2 are used for both read and write. The communication between the master and the DS24B33 takes place either at standard speed (default, OD = 0) or at overdrive speed (OD = 1). If not explicitly set into the overdrive mode, the DS24B33 assumes standard speed.

Write Scratchpad [0Fh]

The Write Scratchpad command applies to the data memory. After issuing the Write Scratchpad command, the master must first provide the 2-byte target address, followed by the data to be written to the scratchpad. The data is written to the scratchpad starting at the byte offset of T[4:0]. The ES bits E[4:0] are loaded with the starting byte offset and increment with each subsequent byte. Effectively, E[4:0] is the byte offset of the last full byte written to the scratchpad. Only full bytes are accepted. If the last byte is incomplete, its content is ignored and PF is set.

When executing the Write Scratchpad command, the CRC generator inside the DS24B33 (Figure 13) calculates a 16-bit CRC of the entire data stream, starting at the command code and ending at the last data byte as sent by the master. This CRC is generated using the CRC-16 polynomial ($X^{16} + X^{15} + X^2 + 1$) by first clearing the CRC generator and then shifting in the command code (0Fh) of the Write Scratchpad command, the target addresses TA1 and TA2 as supplied by the master, and all the data bytes. The master can end the Write Scratchpad command at any time. However, if the end of the scratchpad is reached (E[4:0] = 11111b), the master can send 16 read time slots to receive the CRC generated by the DS24B33.

The DS24B33's memory address range is 0000h to 01FFh. If the bus master sends a target address higher than this, the DS24B33's internal circuitry sets the 7 most significant address bits to zero as they are shifted into the internal address register. The Read Scratchpad command reveals the modified target address. The master identifies such address modifications by comparing the target address read back to the target address transmitted. If the master does not read the scratchpad, a subsequent Copy Scratchpad command does not work because the most significant bits of the target address the master sends do not match the value that the DS24B33 expects.

Read Scratchpad [AAh]

The Read Scratchpad command allows for verifying the target address and the integrity of the scratchpad data. After issuing the command code, the master begins reading. The first 2 bytes are the target address. The next byte is the ending offset/data status byte (E/S) followed by the scratchpad data beginning at the byte offset (T[4:0]). The master should read through the end of the scratchpad. If the master continues reading beyond the end of the scratchpad, all data are logic 1s.

Copy Scratchpad [55h]

The Copy Scratchpad command is used to copy data from the scratchpad to the data memory. After issuing the Copy Scratchpad command, the master must provide a 3-byte authorization pattern, which should have been obtained by an immediately preceding Read Scratchpad command. This 3-byte pattern must exactly match the data contained in the three address registers (TA1, TA2, E/S, in that order). If the pattern matches and the target address is valid, the AA flag is set and the copy begins. The data to be copied is determined by the three address registers. The scratchpad data from the beginning offset through the ending offset is copied to memory, starting at the target address. Anywhere from 1 to 32 bytes can be copied with this command. The duration of the device's internal data transfer is t_{PROG} , during which the voltage on the 1-Wire bus must not fall below V_{PUPMIN} . A pattern of alternating 0s and 1s are transmitted after the data has been copied until the master issues a reset pulse.

Note: Because of the memory architecture of the DS24B33, if a Copy Scratchpad command is interrupted during the write cycle, **two** consecutive Copy Scratchpad commands of the same data to the same location may be necessary to recover. To verify the success of the Copy Scratchpad command, always look for the alternating 0-to-1 pattern at the end of the Copy Scratchpad command flow and also read back the EEPROM page that was to be updated. If the alternating pattern appeared and the EEPROM page data shows the intended new data, the write access was successful. No further action is required. In all other cases (alternating 0-to-1 pattern is not seen or nonmatching EEPROM page data), repeat the Write Scratchpad, Copy Scratchpad sequence until successful.

DS24B33

1-Wire 4Kb EEPROM

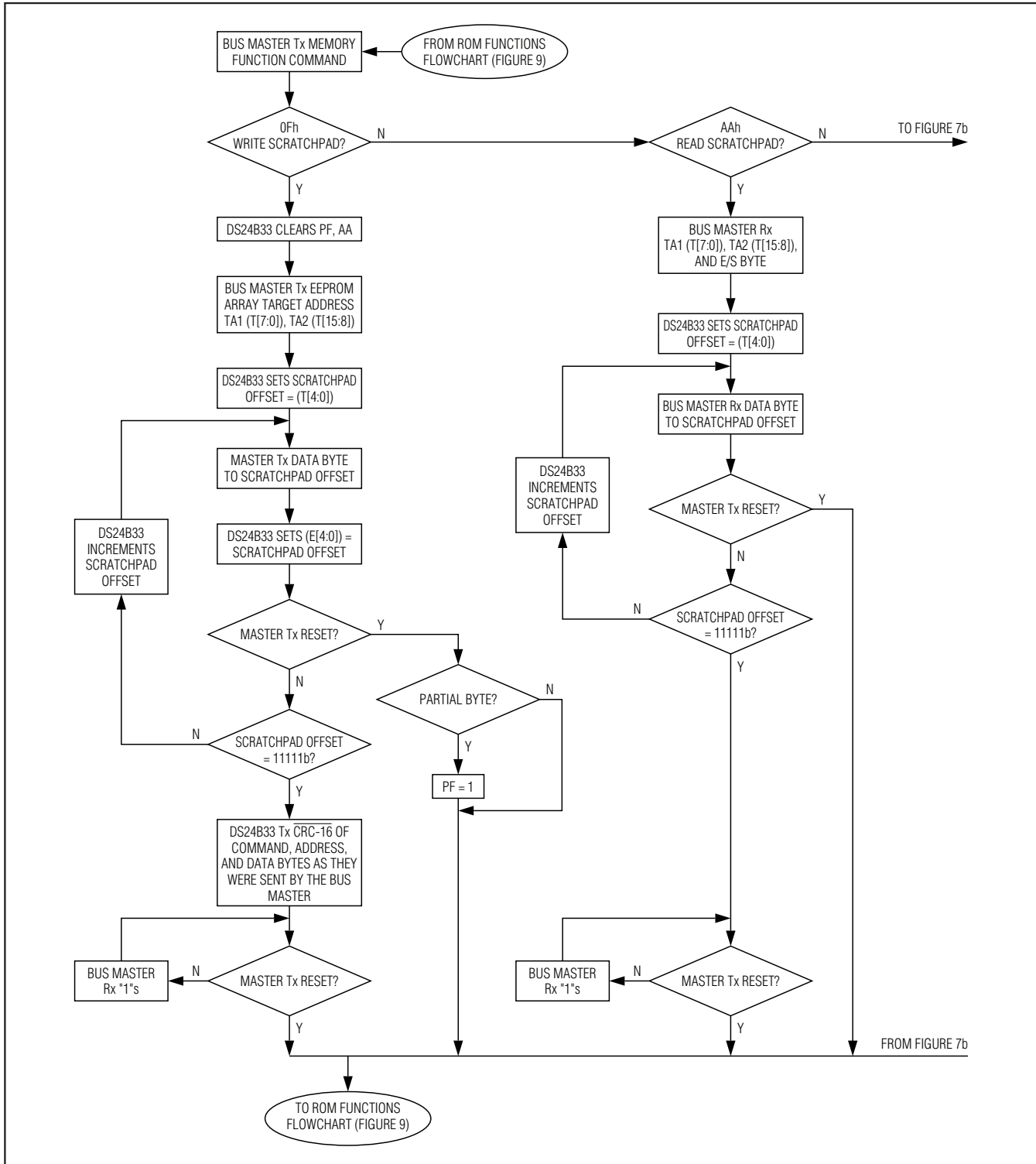

Figure 7a. Memory Function Flowchart

DS24B33

1-Wire 4Kb EEPROM

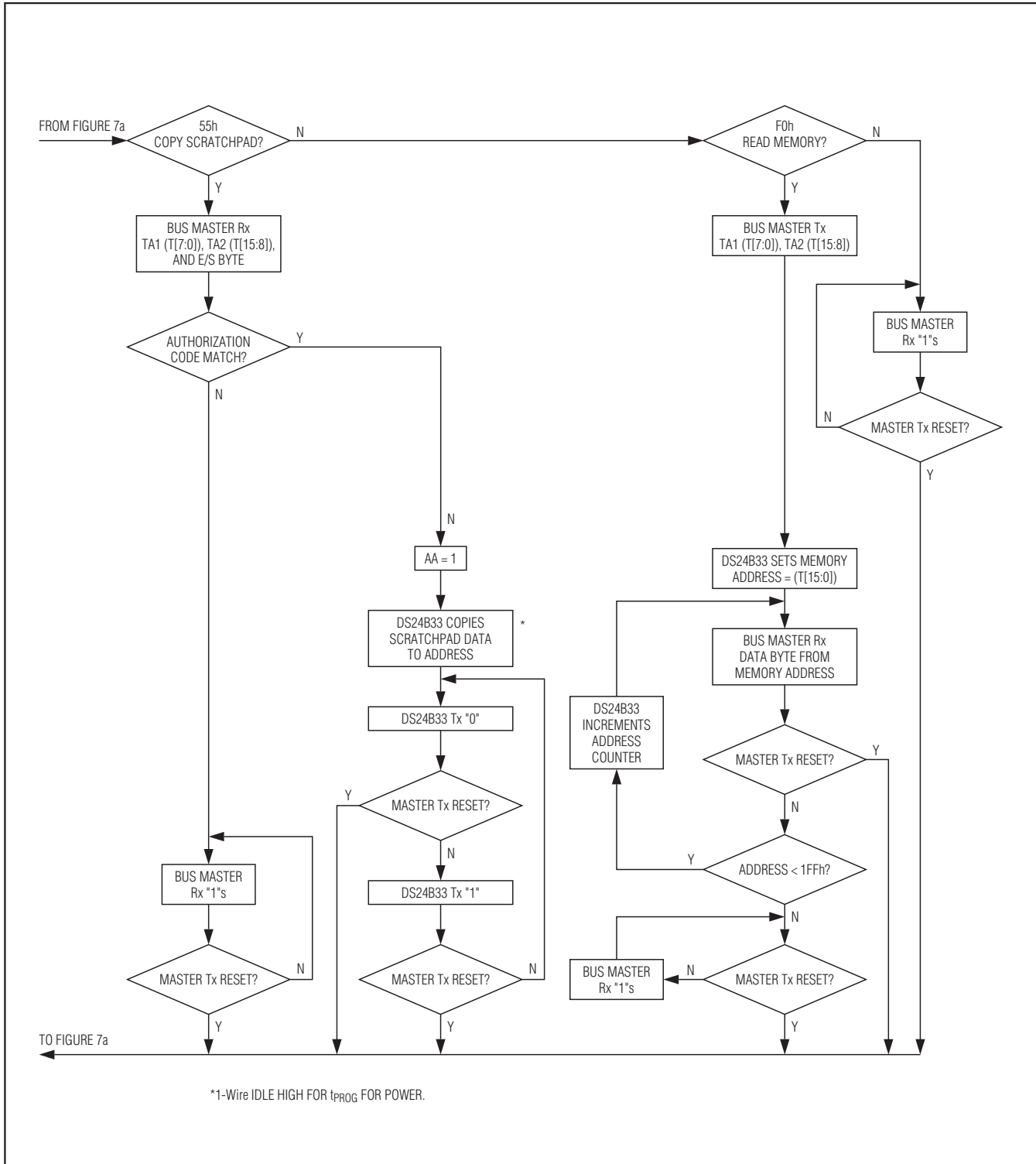

Figure 7b. Memory Function Flowchart (continued)

DS24B33

1-Wire 4Kb EEPROM

Read Memory [F0h]

The Read Memory command is the general function to read from the DS24B33. After issuing the command, the master must provide a 2-byte target address, which should be in the range of 0000h to 01FFh. If the target address is higher than 01FFh, the DS24B33 changes the upper 7 address bits to 0. After the address is transmitted, the master reads data starting at the (modified) target address and can continue until address 01FFh. If the master continues reading, the result is FFh. The Read Memory command can be ended at any point by issuing a reset pulse. Note that the (modified) target address provided with the Read Memory command overwrites the target address that was specified with a previously issued Write Scratchpad command. The Read Memory command overwrites the scratchpad with data from the target memory page. When reading the last byte of a memory page, the scratchpad is loaded with data from the next memory page. This could cause unexpected data to be loaded into the scratchpad.

1-Wire Bus System

The 1-Wire bus is a system that has a single bus master and one or more slaves. In all instances the DS24B33 is a slave device. The bus master is typically a microcontroller. The discussion of this bus system is broken down into three topics: hardware configuration, transaction sequence, and 1-Wire signaling (signal types and timing). The 1-Wire protocol defines bus transactions in terms of the bus state during specific time slots, which are initiated on the falling edge of sync pulses from the bus master.

Hardware Configuration

The 1-Wire bus has only a single line by definition; it is important that each device on the bus be able to drive it at the appropriate time. To facilitate this, each device attached to the 1-Wire bus must have open-drain or three-state outputs. The 1-Wire port of the DS24B33 is open drain with an internal circuit equivalent to that shown in Figure 8.

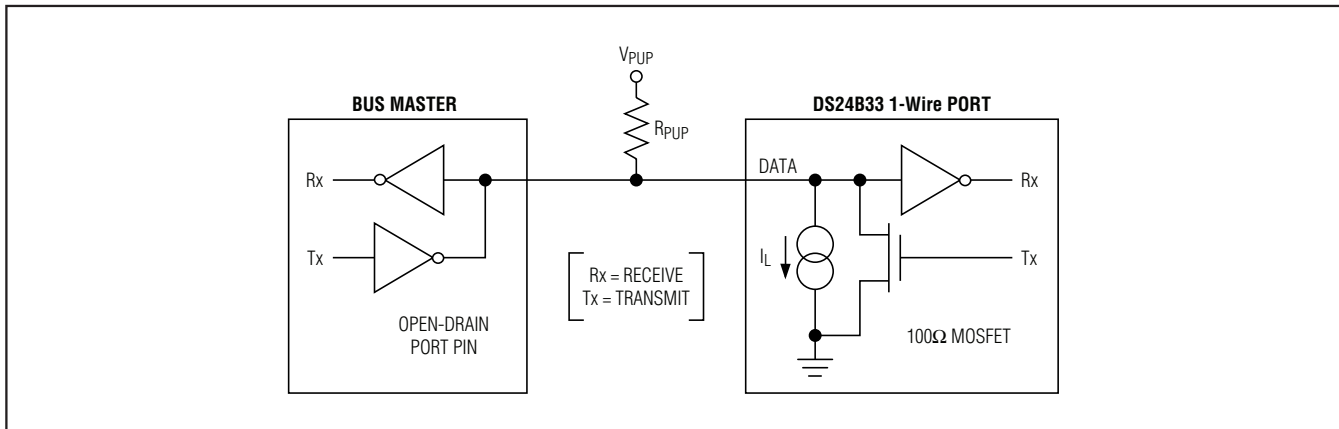

Figure 8. Hardware Configuration

DS24B33

1-Wire 4Kb EEPROM

A multidrop bus consists of a 1-Wire bus with multiple slaves attached. The DS24B33 supports both a standard and overdrive communication speed of 15.4kbps (maximum) and 125kbps (maximum), respectively, over the full pullup voltage range. For pullup voltages of +4.75V and higher, the DS24B33 also supports the legacy communication speed of 16.3kbps and overdrive speed of 142kbps. The slightly reduced rates for the DS24B33 are a result of additional recovery times, which in turn were driven by a 1-Wire physical interface enhancement to improve noise immunity. The value of the pullup resistor primarily depends on the network size and load conditions. The DS24B33 requires a pullup resistor of 2.2k Ω (maximum) at any speed.

The idle state for the 1-Wire bus is high. If for any reason a transaction must be suspended, the bus *must* be left in the idle state if the transaction is to resume. If this does not occur and the bus is left low for more than 16 μ s (overdrive speed) or more than 120 μ s (standard speed), one or more devices on the bus may be reset.

Transaction Sequence

The protocol for accessing the DS24B33 through the 1-Wire port is as follows:

- Initialization
- ROM Function Commands
- Memory Function Commands
- Transaction/Data

Initialization

All transactions on the 1-Wire bus begin with an initialization sequence. The initialization sequence consists of a reset pulse transmitted by the bus master followed by presence pulse(s) transmitted by the slave(s). The presence pulse lets the bus master know that the DS24B33 is on the bus and is ready to operate. For more details, see the *1-Wire Signaling* section.

1-Wire ROM Function Commands

Once the bus master has detected a presence, it can issue one of the seven ROM function commands that the DS24B33 supports. All ROM function commands are 8 bits long. See Figure 9 for a list of these commands.

Read ROM [33h]

This command allows the bus master to read the DS24B33's 8-bit family code, unique 48-bit serial number, and 8-bit CRC. This command can only be used if there is a single slave on the bus. If more than one slave is present on the bus, a data collision occurs when all slaves try to transmit at the same time (open drain produces a wired-AND result). The resultant family code and 48-bit serial number results in a mismatch of the CRC.

Match ROM [55h]

The Match ROM command, followed by a 64-bit ROM sequence, allows the bus master to address a specific DS24B33 on a multidrop bus. Only the DS24B33 that exactly matches the 64-bit ROM sequence responds to the memory function command that follows. All other slaves wait for a reset pulse. This command can be used with a single device or multiple devices on the bus.

Search ROM [F0h]

When a system is initially brought up, the bus master might not know the number of devices on the 1-Wire bus or their registration numbers. By taking advantage of the bus's wired-AND property, the master can use a process of elimination to identify the registration numbers of all slave devices. For each bit of the registration number, starting with the LSB, the bus master issues a triplet of time slots. On the first slot, each slave device participating in the search outputs the true value of its registration number bit. On the second slot, each slave device participating in the search outputs the complemented value of its registration number bit. On the third slot, the master writes the true value of the bit to be selected. All slave devices that do not match the bit written by the master stop participating in the search. If both of the read bits are zero, the master knows that slave devices exist with both states of the bit. By choosing which state to write, the bus master branches in the ROM code tree. After one complete pass, the bus master knows the registration number of a single device. Additional passes identify the registration numbers of the remaining devices. Refer to Application Note 187: *1-Wire Search Algorithm* for a detailed discussion and an example.

DS24B33

1-Wire 4Kb EEPROM

Skip ROM [CCh]

This command can save time in a single-drop bus system by allowing the bus master to access the memory functions without providing the 64-bit ROM code. If more than one slave is present on the bus and, for example, a read command is issued following the Skip ROM command, data collision occurs on the bus as multiple slaves transmit simultaneously (open-drain pulldowns produce a wired-AND result).

Resume [A5h]

To maximize the data throughput in a multidrop environment, the Resume command is available. This command checks the status of the RC bit and, if it is set, directly transfers control to the memory functions, similar to a Skip ROM command. The only way to set the RC bit is by successfully executing the Match ROM, Search ROM, or Overdrive-Match ROM command. Once the RC bit is set, the device can repeatedly be accessed through the Resume command. Accessing another device on the bus clears the RC bit, preventing two or more devices from simultaneously responding to the Resume command.

Overdrive-Skip ROM [3Ch]

On a single-drop bus, this command can save time by allowing the bus master to access the memory functions without providing the 64-bit ROM code. Unlike the normal Skip ROM command, the Overdrive-Skip ROM command sets the DS24B33 in the overdrive mode (OD = 1). All communication following this command must occur at overdrive speed until a reset pulse of minimum 480µs duration resets all devices on the bus to standard speed (OD = 0).

When issued on a multidrop bus, this command sets all overdrive-supporting devices into overdrive mode. To subsequently address a specific overdrive-supporting device, a reset pulse at overdrive speed must be issued followed by a Match ROM or Search ROM command sequence. This speeds up the time for the search process. If more than one slave supporting overdrive is present on the bus and the Overdrive-Skip ROM command is followed by a Read command, data collision occurs on the bus as multiple slaves transmit simultaneously (open-drain pulldowns produce a wired-AND result).

Overdrive-Match ROM [69h]

The Overdrive-Match ROM command followed by a 64-bit ROM sequence transmitted at overdrive speed allows the bus master to address a specific DS24B33 on a multidrop bus and to simultaneously set it in overdrive mode. Only the DS24B33 that exactly matches the 64-bit ROM sequence responds to the subsequent memory function command. Slaves already in overdrive mode from a previous Overdrive-Skip ROM or successful Overdrive-Match ROM command remain in overdrive mode. All overdrive-capable slaves return to standard speed at the next reset pulse of minimum 480µs duration. The Overdrive-Match ROM command can be used with a single device or multiple devices on the bus.

DS24B33

1-Wire 4Kb EEPROM

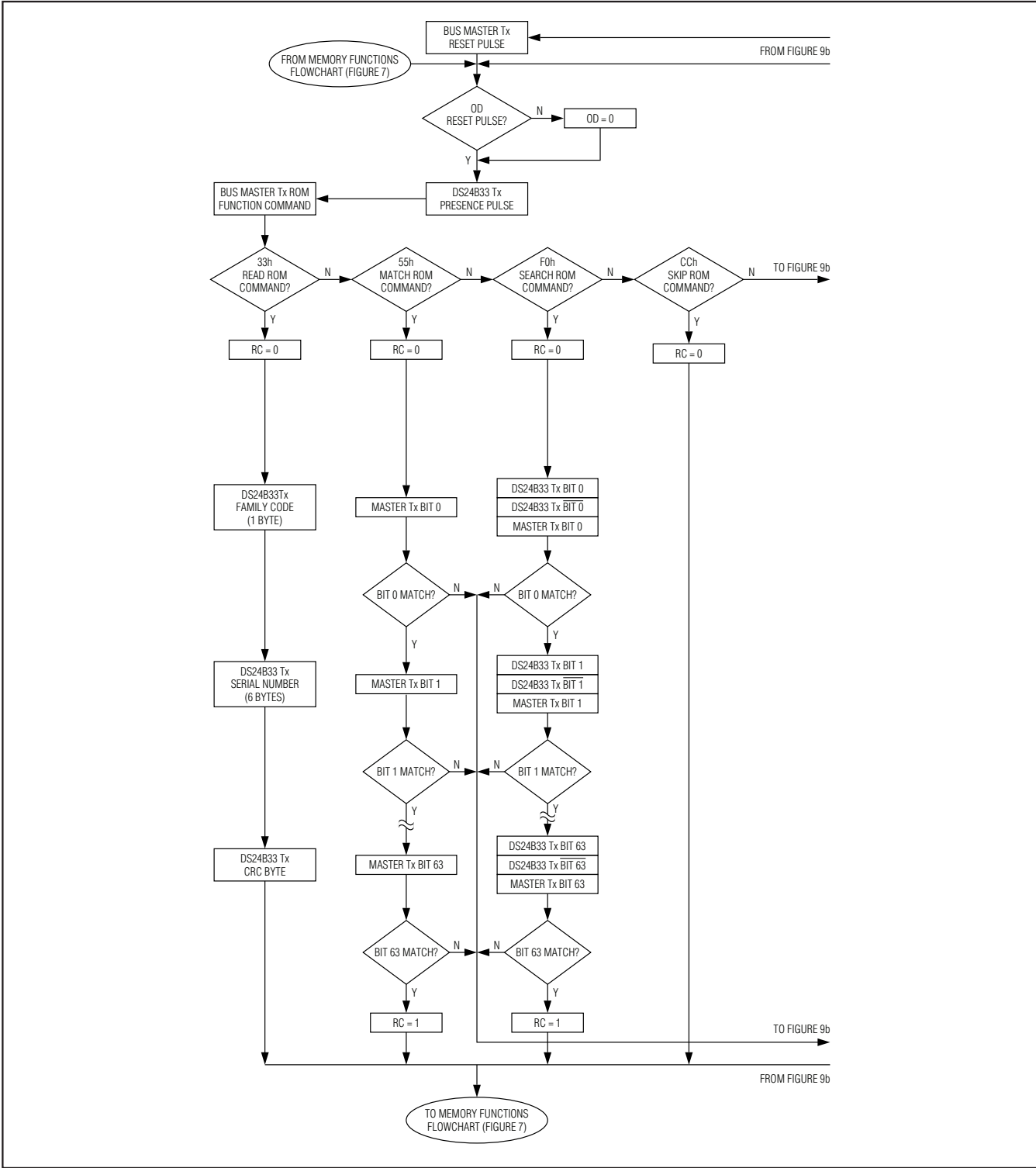

Figure 9a. ROM Functions Flowchart

DS24B33

1-Wire 4Kb EEPROM

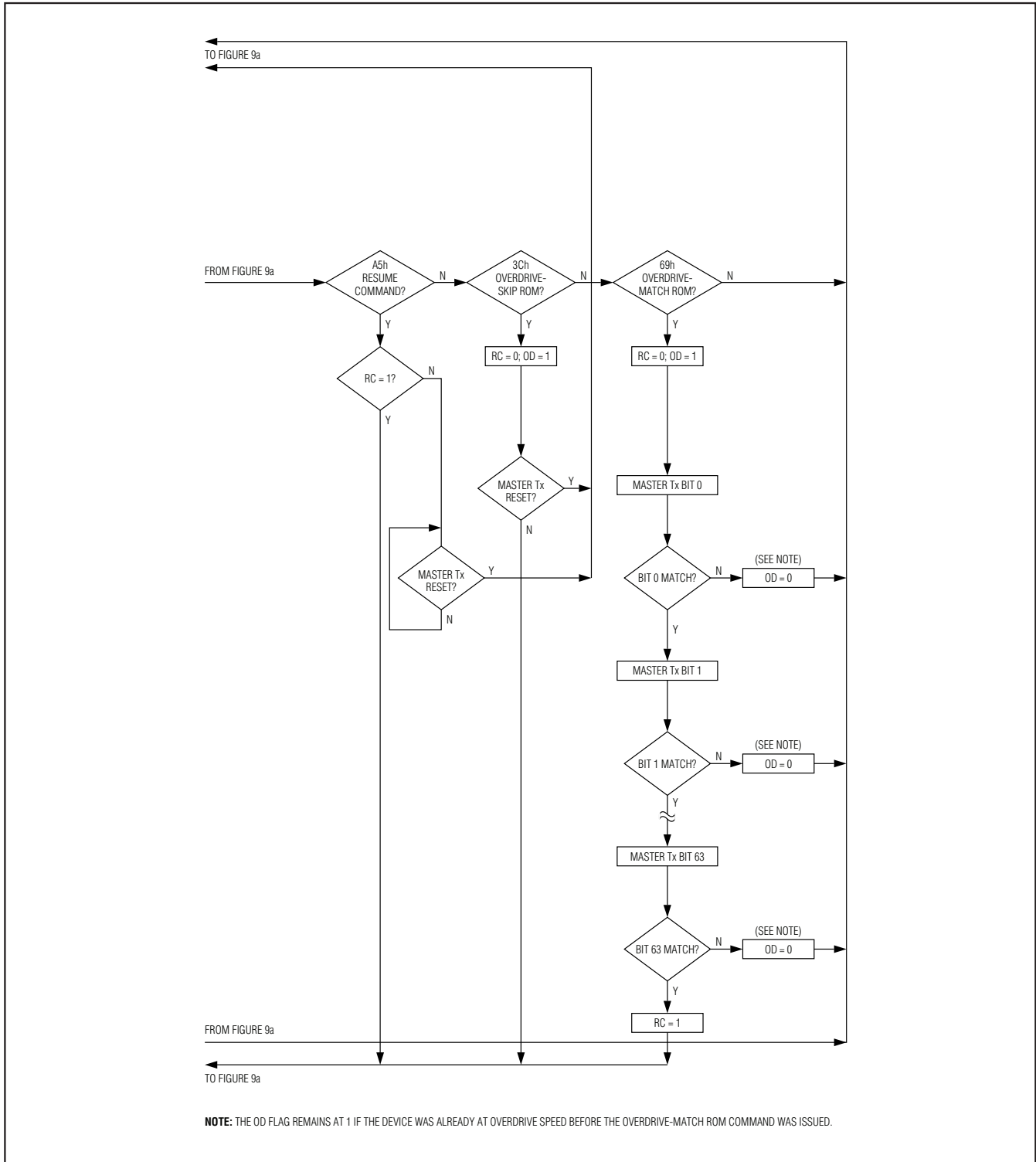

Figure 9b. ROM Functions Flowchart (continued)

DS24B33

1-Wire 4Kb EEPROM

1-Wire Signaling

The DS24B33 requires strict protocols to ensure data integrity. The protocol consists of four types of signaling on one line: reset sequence with reset pulse and presence pulse, write-zero, write-one, and read-data. Except for the presence pulse, the bus master initiates all falling edges. The DS24B33 can communicate at two different speeds: standard speed and overdrive speed. If not explicitly set into the overdrive mode, the DS24B33 communicates at standard speed. While in overdrive mode the fast timing applies to all waveforms.

To get from idle to active, the voltage on the 1-Wire line needs to fall from V_{PUP} below the threshold V_{TL} . To get from active to idle, the voltage needs to rise from V_{ILMAX} past the threshold V_{TH} . The time it takes for the voltage to make this rise is seen in Figure 10 as ϵ , and its duration depends on the pullup resistor (R_{PUP}) used and the capacitance of the 1-Wire network attached. The voltage V_{ILMAX} is relevant for the DS24B33 when determining a logical level, not triggering any events.

Figure 10 shows the initialization sequence required to begin any communication with the DS24B33. A reset pulse followed by a presence pulse indicates that the DS24B33 is ready to receive data, given the correct ROM and memory function command. If the bus master uses slew-rate control on the falling edge, it must pull down the line for $t_{RSTL} + t_f$ to compensate for the edge. A t_{RSTL} duration of $480\mu s$ or longer exits the overdrive mode, returning the device to standard speed. If the DS24B33 is in overdrive mode and t_{RSTL} is no longer than $80\mu s$, the device remains in overdrive mode. If the device is in overdrive mode and t_{RSTL} is between $80\mu s$ and $480\mu s$, the device resets, but the communication speed is undetermined.

After the bus master has released the line it goes into receive mode. Now the 1-Wire bus is pulled to V_{PUP} through the pullup resistor, or in case of a DS2482-x00 or DS2480B driver, by active circuitry. When the threshold V_{TH} is crossed, the DS24B33 waits for t_{PDH} and then transmits a presence pulse by pulling the line low for t_{PDL} . To detect a presence pulse, the master must test the logical state of the 1-Wire line at t_{MSP} .

The t_{RSTH} window must be at least the sum of t_{PDHMAX} , t_{PDLMAX} , and t_{RECMIN} . Immediately after t_{RSTH} is expired, the DS24B33 is ready for data communication. In a mixed population network, t_{RSTH} should be extended to minimum $480\mu s$ at standard speed and $48\mu s$ at overdrive speed to accommodate other 1-Wire devices.

Read/Write Time Slots

Data communication with the DS24B33 takes place in time slots, which carry a single bit each. Write time slots transport data from bus master to slave. Read time slots transfer data from slave to master. Figure 11 illustrates the definitions of the write and read time slots.

All communication begins with the master pulling the data line low. As the voltage on the 1-Wire line falls below the threshold V_{TL} , the DS24B33 starts its internal timing generator that determines when the data line is sampled during a write time slot and how long data is valid during a read time slot.

Master-to-Slave

For a **write-one** time slot, the voltage on the data line must have crossed the V_{TH} threshold before the write-one low time t_{W1LMAX} is expired. For a **write-zero** time slot, the voltage on the data line must stay below the V_{TH} threshold until the write-zero low time t_{W0LMIN} is expired. For the most reliable communication, the

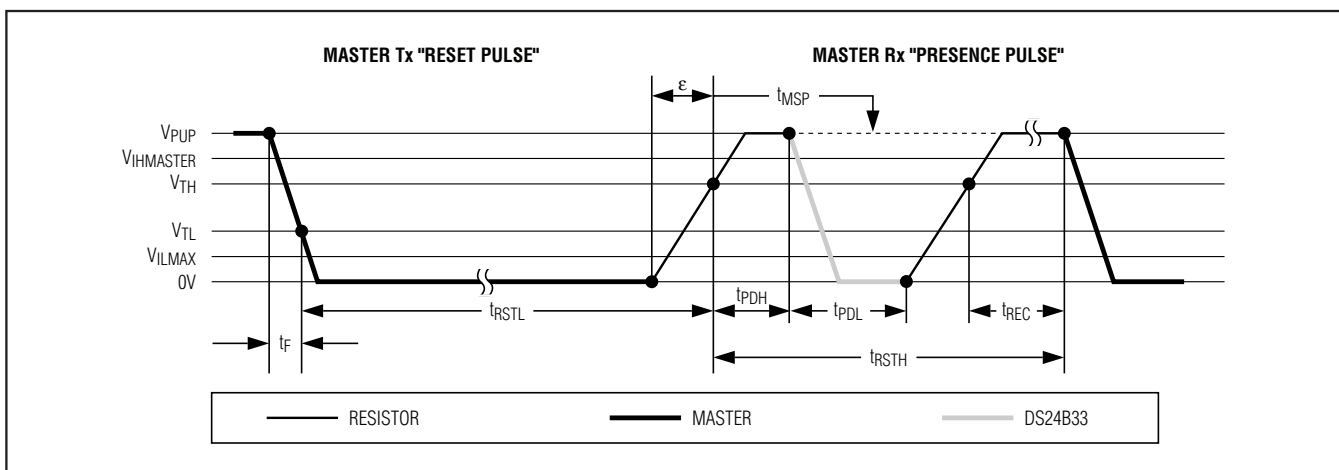

Figure 10. Initialization Procedure: Reset and Presence Pulse

DS24B33

1-Wire 4Kb EEPROM

voltage on the data line should not exceed V_{ILMAX} during the entire t_{WOL} or t_{W1L} window. After the V_{TH} thresh-

old has been crossed, the DS24B33 needs a recovery time t_{REC} before it is ready for the next time slot.

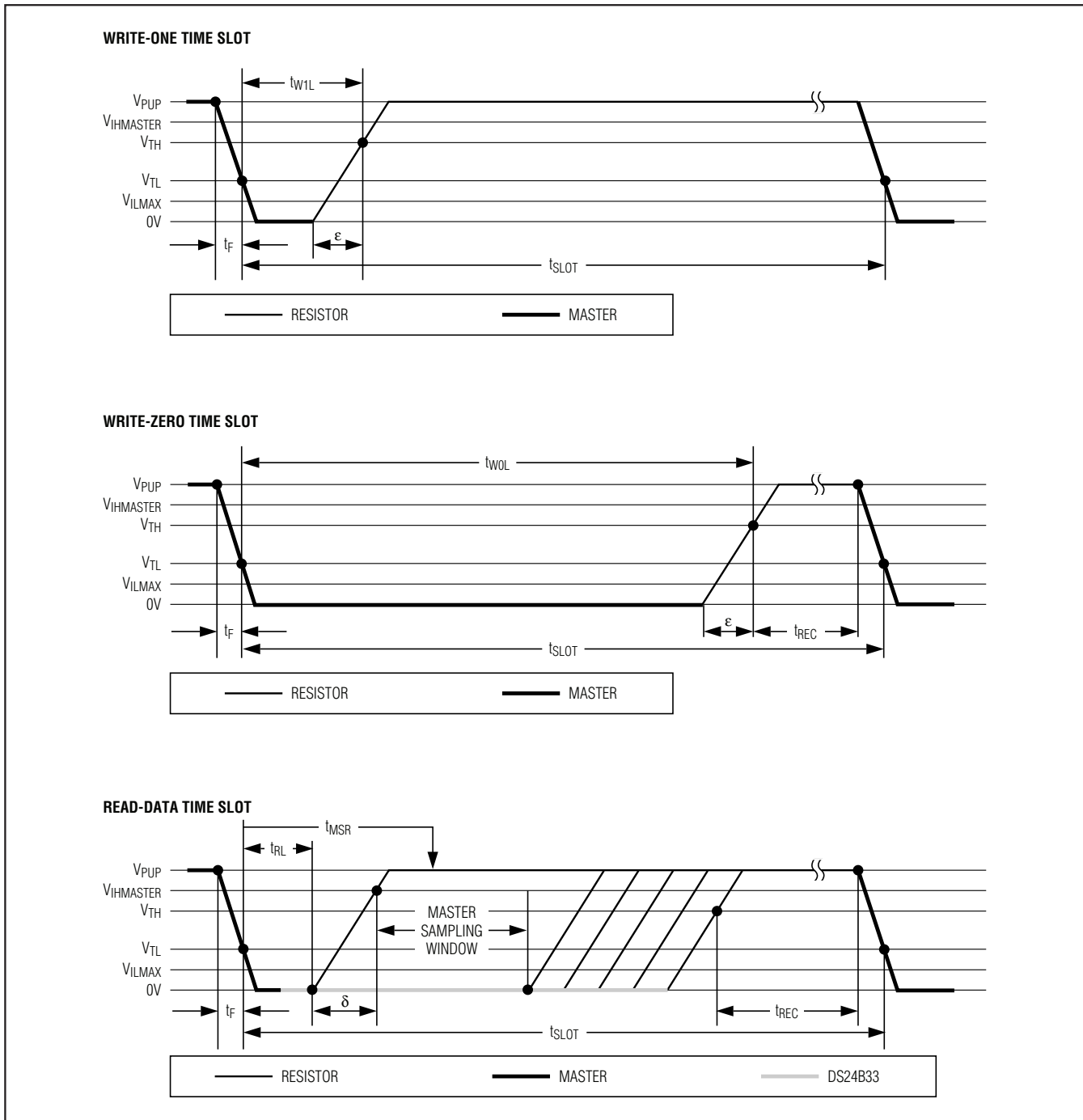

Figure 11. Read/Write Timing Diagrams

DS24B33

1-Wire 4Kb EEPROM

Slave-to-Master

A **read-data** time slot begins like a write-one time slot. The voltage on the data line must remain below V_{TL} until the read low time t_{RL} is expired. During the t_{RL} window, when responding with a 0, the DS24B33 starts pulling the data line low; its internal timing generator determines when this pulldown ends and the voltage starts rising again. When responding with a 1, the DS24B33 does not hold the data line low at all, and the voltage starts rising as soon as t_{RL} is over.

The sum of $t_{RL} + \delta$ (rise time) on one side and the internal timing generator of the DS24B33 on the other side define the master sampling window (t_{MSRMIN} to t_{MSRMAX}) in which the master must perform a read from the data line. For the most reliable communication, t_{RL} should be as short as permissible, and the master should read close to but no later than t_{MSRMAX} . After reading from the data line, the master must wait until t_{SLOT} is expired. This guarantees sufficient recovery time t_{REC} for the DS24B33 to get ready for the next time slot. Note that t_{REC} specified herein applies only to a single DS24B33 attached to a 1-Wire line. For multidevice configurations, t_{REC} needs to be extended to accommodate the additional 1-Wire device input capacitance. Alternatively, an interface that performs active pullup during the 1-Wire recovery time such as the DS2482-x00 or DS2480B 1-Wire line drivers can be used.

Improved Network Behavior (Switchpoint Hysteresis)

In a 1-Wire environment, line termination is possible only during transients controlled by the bus master (1-Wire driver). 1-Wire networks, therefore, are susceptible to noise of various origins. Depending on the physical size and topology of the network, reflections from end points and branch points can add up or cancel each other to some extent. Such reflections are visible as glitches or ringing on the 1-Wire communication line.

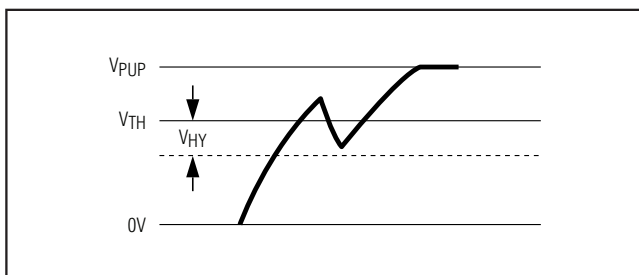

Figure 12. Hysteresis at the Low-to-High Switching Threshold

Noise coupled onto the 1-Wire line from external sources can also result in signal glitching. A glitch during the rising edge of a time slot can cause a slave device to lose synchronization with the master and, consequently, result in a Search ROM command coming to a dead end or cause a device-specific function command to abort. For better performance in network applications, the DS24B33 uses an improved 1-Wire front-end, which makes it less sensitive to noise.

The 1-Wire front-end of the DS24B33 differs from traditional slave devices in one characteristic: There is a hysteresis at the low-to-high switching threshold V_{TH} . If a negative glitch crosses V_{TH} but does not go below $V_{TH} - V_{HY}$, it is not recognized (Figure 12). The hysteresis is effective at any 1-Wire speed.

CRC Generation

The DS24B33 uses two different types of CRCs. One CRC is an 8-bit type and is stored in the most significant byte of the 64-bit registration number. The bus master can compute a CRC value from the first 56 bits of the 64-bit registration number and compare it to the value stored within the DS24B33 to determine if the registration number has been received error-free. The equivalent polynomial function of this CRC is $X^8 + X^5 + X^4 + 1$. This 8-bit CRC is received in the true (noninverted) form. It is computed and programmed into the chip at the factory.

The other CRC is a 16-bit type, generated according to the standardized CRC-16 polynomial function $X^{16} + X^{15} + X^2 + 1$. This CRC is used for fast verification of a data transfer when writing to the scratchpad. In contrast to the 8-bit CRC, the 16-bit CRC is always communicated in the inverted form. A CRC generator inside the DS24B33 (Figure 13) calculates a new 16-bit CRC, as shown in the command flowchart (Figure 7). The bus master compares the CRC value read from the device to the one it calculates from the data, and decides whether to continue with an operation.

With the Write Scratchpad command, the CRC is generated by first clearing the CRC generator and then shifting in the command code, the target addresses TA1 and TA2, and all the data bytes as they were sent by the bus master. The DS24B33 transmits this CRC only if the data bytes written to the scratchpad include scratchpad ending offset 11111b. The data can start at any location within the scratchpad.

For more information on generating CRC values refer to Application Note 27: *Understanding and Using Cyclic Redundancy Checks with Maxim iButton Products*.

DS24B33

1-Wire 4Kb EEPROM

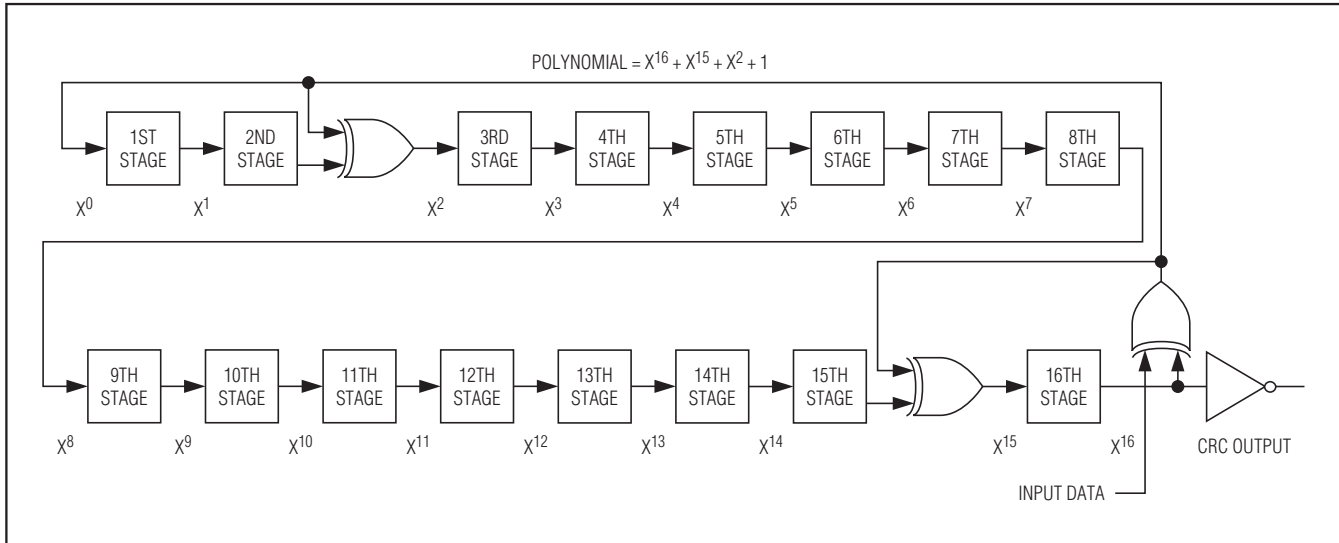

Figure 13. CRC-16 Hardware Description and Polynomial

Command-Specific 1-Wire Communication Protocol—Legend

SYMBOL	DESCRIPTION
RST	1-Wire reset pulse generated by master
PD	1-Wire presence pulse generated by slave
Select	Command and data to satisfy the ROM function protocol
WS	Command: "Write Scratchpad"
RS	Command: "Read Scratchpad"
CPS	Command: "Copy Scratchpad"
RM	Command: "Read Memory"
TA	Target Address TA1, TA2
TA-E/S	Target Address TA1, TA2 with E/S byte
<data to EOS>	Transfer of as many bytes as needed to reach the end of the scratchpad for a given target address
<data to EOM>	Transfer of as many bytes as are needed to reach the end of the memory
$\overline{\text{CRC-16}}$	Transfer of an inverted CRC-16
FF loop	Indefinite loop where the master reads FF bytes
AA loop	Indefinite loop where the master reads AA bytes
Programming	Data transfer to EEPROM; no activity on the 1-Wire bus permitted during this time

DS24B33

1-Wire 4Kb EEPROM

Command-Specific 1-Wire Communication Protocol—Color Codes

Master-to-Slave	Slave-to-Master	Programming
-----------------	-----------------	-------------

1-Wire Communication Examples

Write Scratchpad, Reaching the End of the Scratchpad

RST	PD	Select	WS	TA	<data to EOS>	CRC-16	FF loop
-----	----	--------	----	----	---------------	--------	---------

Read Scratchpad

RST	PD	Select	RS	TA-E/S	<data to EOS>	FF loop
-----	----	--------	----	--------	---------------	---------

Copy Scratchpad (Success)

RST	PD	Select	CPS	TA-E/S	Programming	AA loop
-----	----	--------	-----	--------	-------------	---------

Copy Scratchpad (Fail TA-E/S)

RST	PD	Select	CPS	TA-E/S	FF loop
-----	----	--------	-----	--------	---------

Read Memory

RST	PD	Select	RM	TA	<data to EOM>	FF loop
-----	----	--------	----	----	---------------	---------

DS24B33

1-Wire 4Kb EEPROM

SFN Package Orientation on Tape and Reel

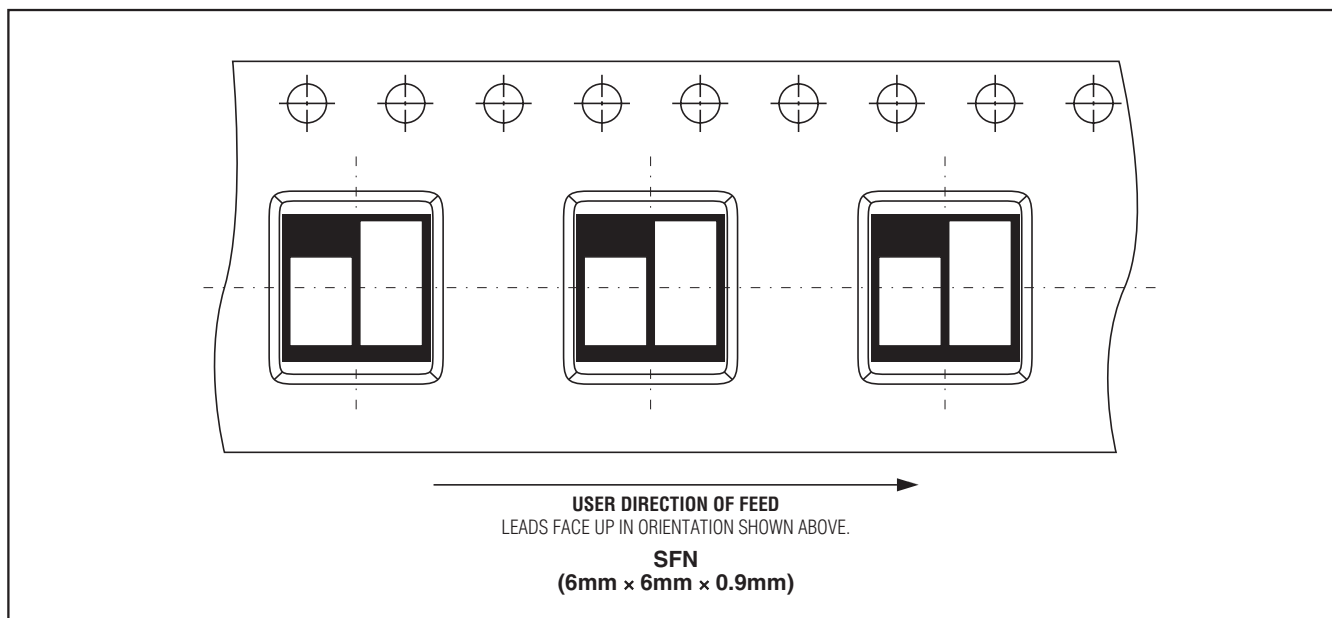

Package Information

For the latest package outline information and land patterns (footprints), go to www.maxim-ic.com/packages. Note that a "+", "#", or "-" in the package code indicates RoHS status only. Package drawings may show a different suffix character, but the drawing pertains to the package regardless of RoHS status.

PACKAGE TYPE	PACKAGE CODE	OUTLINE NO.	LAND PATTERN NO.
8 SO	W8+2	21-0262	90-0258
3 TO-92 (Bulk)	Q3+1	21-0248	—
3 TO-92 (T&R)	Q3+4	21-0250	—
2 SFN	G266N+1	21-0390	—
6 TDFN-EP	T633+2	21-0137	90-0058

DS24B33

1-Wire 4Kb EEPROM

Revision History

REVISION NUMBER	REVISION DATE	DESCRIPTION	PAGES CHANGED
0	2/11	Initial release	—
1	5/11	Implemented text changes to better market the document	1
2	3/12	Revised the <i>Electrical Characteristics</i> table notes 1, 5, and 15.	3
3	5/12	Added the SFN (6mm x 6mm x 0.9mm) and TDFN (3mm x 3mm) packages	1, 2, 4, 5, 22



Maxim cannot assume responsibility for use of any circuitry other than circuitry entirely embodied in a Maxim product. No circuit patent licenses are implied. Maxim reserves the right to change the circuitry and specifications without notice at any time. The parametric values (min and max limits) shown in the Electrical Characteristics table are guaranteed. Other parametric values quoted in this data sheet are provided for guidance.

Maxim Integrated 160 Rio Robles, San Jose, CA 95134 USA 1-408-601-1000

&

Компания «Life Electronics» занимается поставками электронных компонентов импортного и отечественного производства от производителей и со складов крупных дистрибьюторов Европы, Америки и Азии.

С конца 2013 года компания активно расширяет линейку поставок компонентов по направлению коаксиальный кабель, кварцевые генераторы и конденсаторы (керамические, пленочные, электролитические), за счёт заключения дистрибьюторских договоров

Мы предлагаем:

- Конкурентоспособные цены и скидки постоянным клиентам.
- Специальные условия для постоянных клиентов.
- Подбор аналогов.
- Поставку компонентов в любых объемах, удовлетворяющих вашим потребностям.
- Приемлемые сроки поставки, возможна ускоренная поставка.
- Доставку товара в любую точку России и стран СНГ.
- Комплексную поставку.
- Работу по проектам и поставку образцов.
- Формирование склада под заказчика.
- Сертификаты соответствия на поставляемую продукцию (по желанию клиента).
- Тестирование поставляемой продукции.
- Поставку компонентов, требующих военную и космическую приемку.
- Входной контроль качества.
- Наличие сертификата ISO.

В составе нашей компании организован Конструкторский отдел, призванный помогать разработчикам, и инженерам.

Конструкторский отдел помогает осуществить:

- Регистрацию проекта у производителя компонентов.
- Техническую поддержку проекта.
- Защиту от снятия компонента с производства.
- Оценку стоимости проекта по компонентам.
- Изготовление тестовой платы монтаж и пусконаладочные работы.



Тел: +7 (812) 336 43 04 (многоканальный)
Email: org@lifeelectronics.ru