

I²C HUMIDITY AND TWO-ZONE TEMPERATURE SENSOR

Features

- Precision Relative Humidity Sensor
 - ± 3% RH (max), 0–80% RH
- High Accuracy Temperature Sensor
 - ±0.4 °C (max), –10 to 85 °C
- 0 to 100% RH operating range
- Up to –40 to +125 °C operating range
- Low Voltage Operation (1.9 to 3.6 V)
- Low Power Consumption
 - 150 µA active current
 - 60 nA standby current
- Factory-calibrated
- I²C Interface
- Integrated on-chip heater
- Auxiliary Sensor input
 - Direct readout of remote thermistor temperature in °C
- Package: 3x3 mm DFN
- Excellent long term stability
- Optional factory-installed cover
 - Low-profile
 - Protection during reflow
 - Excludes liquids and particulates

Applications

- HVAC/R
- Thermostats/humidistats
- Instrumentation
- White goods
- Micro-environments/data centers
- Industrial Controls
- Indoor weather stations

Description

The Si7013 I²C Humidity and 2-Zone Temperature Sensor is a monolithic CMOS IC integrating humidity and temperature sensor elements, an analog-to-digital converter, signal processing, calibration data, and an I²C Interface. The patented use of industry-standard, low-K polymeric dielectrics for sensing humidity enables the construction of low-power, monolithic CMOS Sensor ICs with low drift and hysteresis, and excellent long term stability.

The humidity and temperature sensors are factory-calibrated and the calibration data is stored in the on-chip non-volatile memory. This ensures that the sensors are fully interchangeable, with no recalibration or software changes required.

An auxiliary sensor input with power management can be tied directly to an external thermistor network or other voltage-output sensor. On-board logic performs calibration/linearization of the external input using user-programmable coefficients. The least-significant bit of the Si7013's I²C address is programmable, allowing two devices to share the same bus.

The Si7013 is available in a 3x3 mm DFN package and is reflow solderable. The optional factory-installed cover offers a low profile, convenient means of protecting the sensor during assembly (e.g., reflow soldering) and throughout the life of the product, excluding liquids (hydrophobic/oleophobic) and particulates.

The Si7013 offers an accurate, low-power, factory-calibrated digital solution ideal for measuring humidity, dew-point, and temperature, in applications ranging from HVAC/R and asset tracking to industrial and consumer platforms.

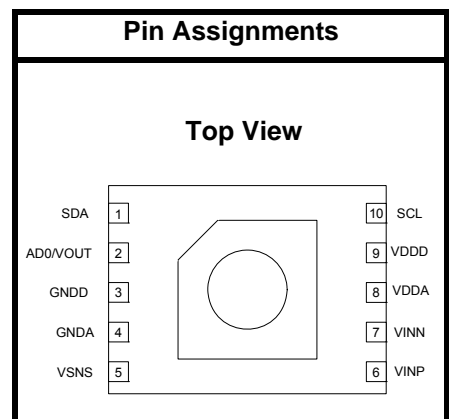

Patent Protected. Patents pending

Si7013-A10

Functional Block Diagram

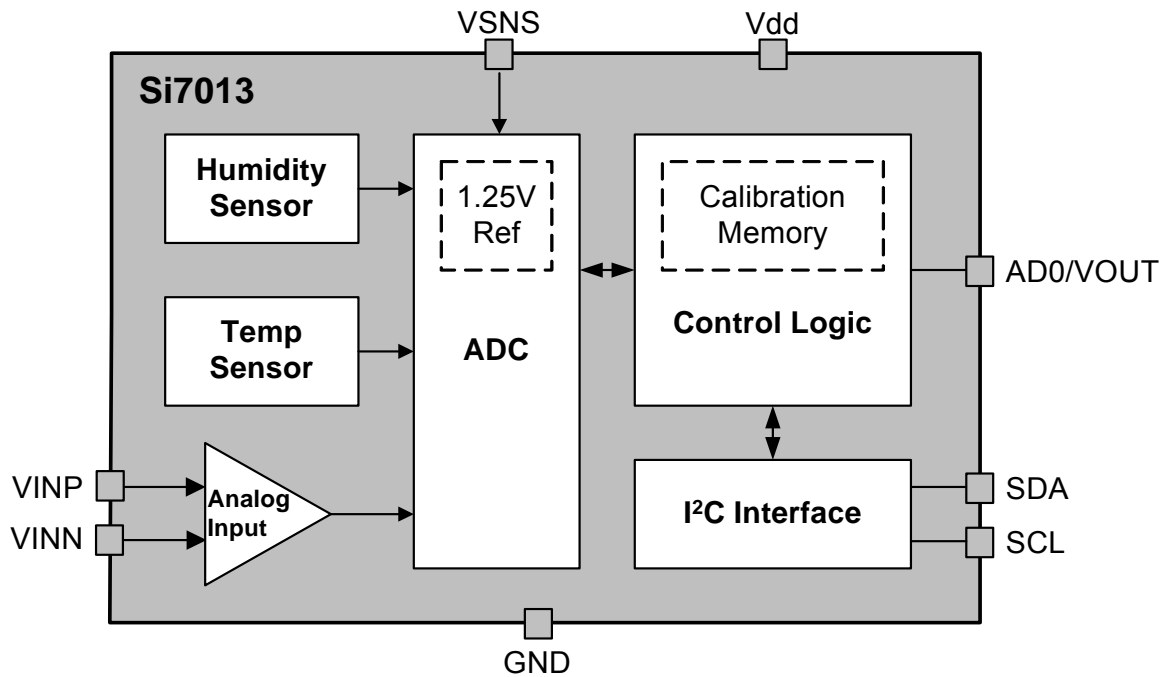

TABLE OF CONTENTS

<u>Section</u>	<u>Page</u>
1. Electrical Specifications	4
2. Typical Application Circuits	12
3. Bill of Materials	14
4. Functional Description	15
4.1. Relative Humidity Sensor Accuracy	16
4.2. Hysteresis	17
4.3. Prolonged Exposure to High Humidity	17
4.4. PCB Assembly	17
4.5. Protecting the Sensor	19
4.6. Bake/Hydrate Procedure	20
4.7. Long Term Drift/Aging	20
5. I2C Interface	21
5.1. Issuing a Measurement Command	22
5.2. Reading and Writing User Registers	25
5.3. Measuring Analog Voltage	25
5.4. Nonlinear Correction of Voltage Inputs:	26
5.5. Firmware Revision	31
5.6. Heater	31
5.7. Electronic Serial Number	32
6. Control Registers	33
6.1. Register Descriptions	34
7. Pin Descriptions: Si7013 (Top View)	37
8. Ordering Guide	38
9. Package Outline	39
9.1. Package Outline: 3x3 10-pin DFN	39
9.2. Package Outline: 3x3 10-pin DFN with Protective Cover	40
10. PCB Land Pattern and Solder Mask Design	41
11. Top Marking	42
11.1. Si7013 Top Marking	42
11.2. Top Marking Explanation	42
12. Additional Reference Resources	43
Document Change List	44
Contact Information	45

Si7013-A10

1. Electrical Specifications

Unless otherwise specified, all min/max specifications apply over the recommended operating conditions.

Table 1. Recommended Operating Conditions

Parameter	Symbol	Test Condition	Min	Typ	Max	Unit
Power Supply	V _{DD}		1.9	—	3.6	V
Operating Temperature	T _A	I and Y grade	-40	—	+125	°C
Operating Temperature	T _A	G grade	-40	—	+85	°C

Table 2. General Specifications

1.9 ≤ V_{DD} ≤ 3.6 V; T_A = -40 to 85 °C (G grade) or -40 to 125 °C (I/Y grade); default conversion time unless otherwise noted.

Parameter	Symbol	Test Condition	Min	Typ	Max	Unit
Input Voltage High	V _{IH}	AD0, SCL, SDA, VSNS pins	0.7xV _{DD}	—	—	V
Input Voltage Low	V _{IL}	AD0, SCL, SDA, VSNS pins	—	—	0.3xV _{DD}	V
Input Voltage Range	V _{IN}	SCL, SDA, VSNS pins with respect to GND	0.0	—	V _{DD}	V
Input Leakage	I _{IL}	SCL, SDA pins; V _{IN} = GND	—	—	1	μA
		VSNS pin (200K nominal pull up); V _{in} = GND	5xV _{DD}			μA
Output Voltage Low	V _{OL}	SDA pin; I _{OL} = 2.5 mA; V _{DD} = 3.3 V	—	—	0.6	V
		SDA pin; I _{OL} = 1.2 mA; V _{DD} = 1.9 V	—	—	0.4	V
Output Voltage High	V _{OH}	V _{OUT} pin, I _{OH} = -0.5 mA, V _{DD} = 2.0 V	V _{DD} - 0.2	—	—	V
		V _{OUT} pin, I _{OH} = -10 μA	V _{DD} - 0.1	—	—	V
		V _{OUT} pin, I _{OH} = -1.7 mA, V _{DD} = 3.0 V	V _{DD} - 0.4	—	—	V

Notes:

1. Initiating a RH measurement will also automatically initiate a temperature measurement. The total conversion time will be t_{CONV(RH)} + t_{CONV(T)}.
2. No conversion or I²C transaction in progress. Typical values measured at 25 °C.
3. Occurs once during powerup. Duration is <5 msec.
4. Occurs during I²C commands for Reset, Read/Write User Registers, Read EID, Read Firmware Version, Read/Write Thermistor Coefficients and Measure Analog Voltage or Thermistor Temperature. Duration is <50 μs for all commands except Measure Analog Voltage or Thermistor Temperature, which has <150 μs duration when Thermistor Correction is enabled.
5. I_{DD} after a user register write. Initiating any other subsequent I²C transaction on the same bus (such as a user register read, starting an RH measurement, or traffic directed at other I²C devices) will transition the device to standby mode.
6. Additional current consumption when HTRE bit enabled. See Section "5.6. Heater" for more information.

Table 2. General Specifications (Continued)

1.9 ≤ V_{DD} ≤ 3.6 V; T_A = –40 to 85 °C (G grade) or –40 to 125 °C (I/Y grade); default conversion time unless otherwise noted.

Parameter	Symbol	Test Condition	Min	Typ	Max	Unit
Current Consumption	I _{DD}	RH conversion in progress	—	150	180	μA
		Temperature conversion in progress	—	90	120	μA
		Standby, –40 to +85 °C ²	—	0.06	0.62	μA
		Standby, –40 to +125 °C ²	—	0.06	3.8	μA
		Peak IDD during powerup ³	—	3.5	4.0	mA
		Peak IDD during I ² C operations ⁴	—	3.5	4.0	mA
		After writing to user registers ⁵	—	20	—	μA
Heater Current ⁶	I _{HEAT}		—	3.1 to 94.2	—	mA
Conversion Time ¹	t _{CONV}	12-bit RH	—	10	12	ms
		11-bit RH	—	5.8	7	
		10-bit RH	—	3.7	4.5	
		8-bit RH	—	2.6	3.1	
		14-bit temperature	—	7	10.8	
		13-bit temperature	—	4	6.2	
		12-bit temperature	—	2.4	3.8	
		11-bit temperature	—	1.5	2.4	
		Voltage Normal	—	—	7	
		Voltage Fast	—	—	3.1	
Powerup Time	t _{PU}	From V _{DD} ≥ 1.9 V to ready for a conversion, 25 °C	—	18	25	ms
		From V _{DD} ≥ 1.9 V to ready for a conversion, full temperature range	—	—	80	ms
		After issuing a software reset command	—	5	15	ms

Notes:

1. Initiating a RH measurement will also automatically initiate a temperature measurement. The total conversion time will be t_{CONV}(RH) + t_{CONV}(T).
2. No conversion or I²C transaction in progress. Typical values measured at 25 °C.
3. Occurs once during powerup. Duration is <5 msec.
4. Occurs during I²C commands for Reset, Read/Write User Registers, Read EID, Read Firmware Version, Read/Write Thermistor Coefficients and Measure Analog Voltage or Thermistor Temperature. Duration is <50 μs for all commands except Measure Analog Voltage or Thermistor Temperature, which has <150 μs duration when Thermistor Correction is enabled.
5. IDD after a user register write. Initiating any other subsequent I²C transaction on the same bus (such as a user register read, starting an RH measurement, or traffic directed at other I²C devices) will transition the device to standby mode.
6. Additional current consumption when HTRE bit enabled. See Section "5.6. Heater" for more information.

Si7013-A10

Table 3. I²C Interface Specifications¹

1.9 ≤ V_{DD} ≤ 3.6 V; T_A = -40 to +85 °C (G grade) or -40 to +125 °C (I/Y grade) unless otherwise noted.

Parameter	Symbol	Test Condition	Min	Typ	Max	Unit
Hysteresis	V _{HYS}	High-to-low versus low-to-high transition	0.05 x V _{DD}	—	—	V
SCLK Frequency ²	f _{SCL}		—	—	400	kHz
SCL High Time	t _{SKH}		0.6	—	—	μs
SCL Low Time	t _{SKL}		1.3	—	—	μs
Start Hold Time	t _{STH}		0.6	—	—	μs
Start Setup Time	t _{STS}		0.6	—	—	μs
Stop Setup Time	t _{SPS}		0.6	—	—	μs
Bus Free Time	t _{BUF}	Between Stop and Start	1.3	—	—	μs
SDA Setup Time	t _{DS}		100	—	—	ns
SDA Hold Time	t _{DH}		100	—	—	ns
SDA Valid Time	t _{VD;DAT}	From SCL low to data valid	—	—	0.9	μs
SDA Acknowledge Valid Time	t _{VD;ACK}	From SCL low to data valid	—	—	0.9	μs
Suppressed Pulse Width ³	t _{SP}		50	—	—	ns

Notes:

1. All values are referenced to V_{IL} and/or V_{IH}.
2. Depending on the conversion command, the Si7013 may hold the master during the conversion (clock stretch). At above 300 kHz SCL, the Si7013 may hold the master briefly for user register and device ID transactions. At the highest I²C speed of 400 kHz the stretching will be <10 μs.
3. Pulses up to and including 50ns will be suppressed.

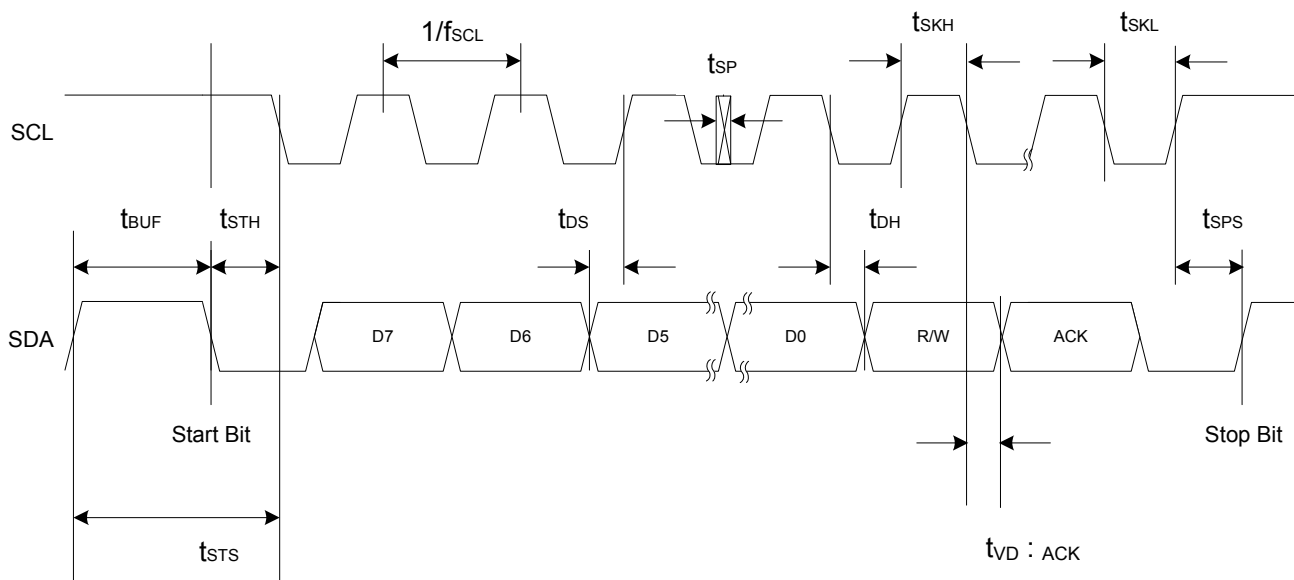

Figure 1. I²C Interface Timing Diagram

Table 4. Humidity Sensor

$1.9 \leq V_{DD} \leq 3.6$ V; $T_A = 30$ °C; default conversion time unless otherwise noted.

Parameter	Symbol	Test Condition	Min	Typ	Max	Unit
Operating Range ¹		Non-condensing	0	—	100	%RH
Accuracy ^{2, 3}		0 – 80% RH	—	±2	±3	%RH
		80 – 100% RH	See Figure 2			%RH
Repeatability-Noise		12-bit resolution	—	0.025	—	%RH RMS
		11-bit resolution	—	0.05	—	%RH RMS
		10-bit resolution	—	0.1	—	%RH RMS
		8-bit resolution	—	0.2	—	%RH RMS
Response Time ⁴	$T_{63\%}$	1 m/s airflow	—	18	—	S
Drift vs. Temperature			—	0.05	—	%RH/°C
Hysteresis			—	±1	—	%RH
Long Term Stability ³			—	≤ 0.25	—	%RH/yr
Notes:						
<ol style="list-style-type: none"> 1. Recommended humidity operating range is 20% to 80% RH (non-condensing) over –10 °C to 60 °C. Prolonged operation beyond these ranges may result in a shift of sensor reading with slow recovery time. 2. Excludes hysteresis, long term drift, and certain other factors and is applicable to non-condensing environments only. See Section “4.1. Relative Humidity Sensor Accuracy” for more details. 3. Drift due to aging effects at typical room conditions of 30°C and 30% to 50% RH. May be impacted by dust, vaporized solvents or other contaminants, e.g., out-gassing tapes, adhesives, packaging materials, etc. See Section “4.7. Long Term Drift/Aging” 4. Response time to a step change in RH. Time for the RH output to change by 63% of the total RH change. 						

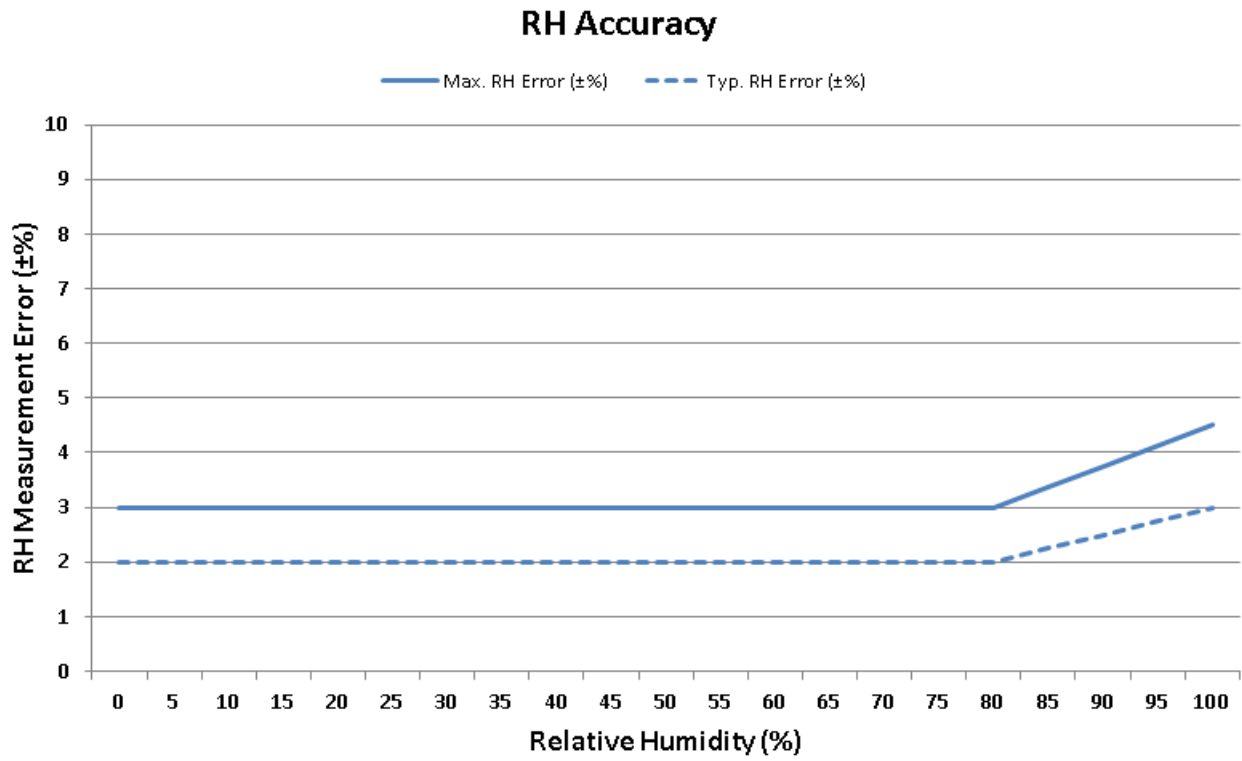

Figure 2. RH Accuracy at 30 °C

Table 5. Temperature Sensor

$1.9 \leq V_{DD} \leq 3.6$ V; $T_A = -40$ to $+85$ °C (G grade) or -40 to $+125$ °C (I/Y grade), default conversion time unless otherwise noted.

Parameter	Symbol	Test Condition	Min	Typ	Max	Unit
Operating Range		I and Y Grade	-40	—	+125	°C
		G Grade	-40	—	+85	°C
Accuracy ¹		-10 °C $\leq t_A \leq 85$ °C	—	± 0.3	± 0.4	°C
		-40 °C $\leq t_A \leq 125$ °C	Figure 3			°C
Repeatability-Noise		14-bit resolution	—	0.01	—	°C RMS
		13-bit resolution	—	0.02	—	°C RMS
		12-bit resolution	—	0.04	—	°C RMS
		11-bit resolution	—	0.08	—	°C RMS
Response Time ²	$T_{63\%}$	Unmounted device	—	0.7	—	s
		Si7013-EB board	—	5.1	—	s
Long Term Stability			—	≤ 0.01	—	°C/Yr

Notes:

- 14b measurement resolution (default).
- Time to reach 63% of final value in response to a step change in temperature. Actual response time will vary dependent on system thermal mass and airflow.

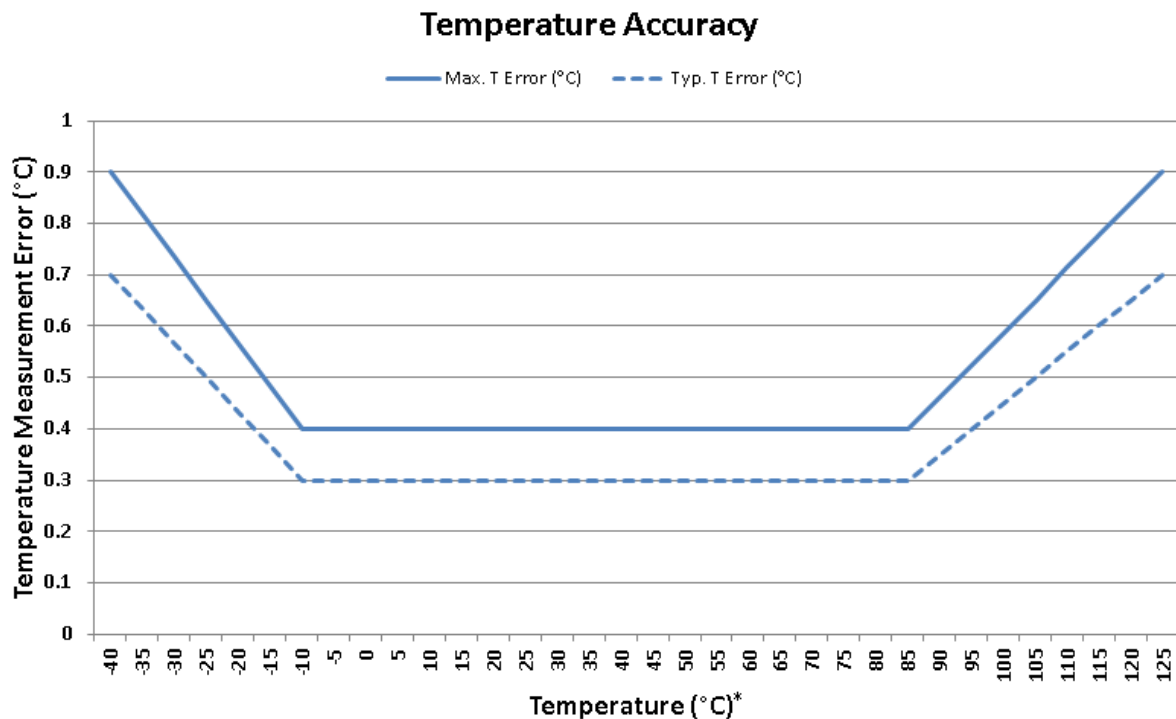
**Figure 3. Temperature Accuracy***

*Note: Applies only to I and Y devices beyond $+85$ °C.

Si7013-A10

Table 6. Voltage Converter Specifications

$1.9 \leq V_{DD} \leq 3.6$ V; $T_A = -40$ to $+85$ °C (G grade) or -40 to $+125$ °C (I/Y grade); normal mode conversion time, $V_{REF} = 1.25$ V internal or V_{DDA} , buffered and unbuffered mode, unless otherwise noted.

Parameter	Symbol	Test Condition	Min	Typ	Max	Unit
Resolution			—	$V_{REF}/32768$	—	V
Integral Non-linearity	INL	$ VINP-VINN < V_{REF}/2$	—	1	—	LSB
Differential Non-linearity	DNL	$ VINP-VINN < V_{REF}/2$	—	1	—	LSB
Noise	N	$ VINP-VINN < V_{REF}/2$, $V_{REF} = 1.25$ V, Normal Mode	—	25	—	μV_{RMS}
		$ VINP-VINN < V_{REF}/2$, $V_{REF} = 1.25$ V, Fast Mode	—	50	—	
Input Offset (Buffered Mode)	V_{OS}	$ VINP-VINN = 0$	—	—	10	mV
Input Offset (Unbuffered Mode) ^{1,2}	V_{OS}	$ VINP-VINN = 0$	—	—	1	mV
Gain Accuracy	ΔG	$V_{REF} = 1.25$ V; gain is absolute	—	± 1	± 2	%
		$V_{REF} = V_{DD}$; gain is relative to V_{DD}	—	± 0.25	± 0.5	%

Notes:

- Guaranteed by design.
- In unbuffered mode, $R_{IN} * C_{IN}$ should be < 0.5 usec. C_{IN} minimum is around 10 pF.

Table 7. Thermal Characteristics

Parameter	Symbol	Test Condition	DFN-6	Unit
Junction to Air Thermal Resistance	θ_{JA}	JEDEC 2-Layer board, No Airflow	236	°C/W
Junction to Air Thermal Resistance	θ_{JA}	JEDEC 2-Layer board, 1 m/s Airflow	203	°C/W
Junction to Air Thermal Resistance	θ_{JA}	JEDEC 2-Layer board, 2.5 m/s Airflow	191	°C/W
Junction to Case Thermal Resistance	θ_{JC}	JEDEC 2-Layer board	20	°C/W
Junction to Board Thermal Resistance	θ_{JB}	JEDEC 2-Layer board	112	°C/W

Table 8. Absolute Maximum Ratings^{1,2}

Parameter	Symbol	Test Condition	Min	Typ	Max	Unit
Ambient temperature under bias			-55	—	125	°C
Storage Temperature			-65	—	150	°C
Voltage on I/O pins			-0.3	—	VDD+0.3V	V
Voltage on VDD with respect to GND			-0.3	—	4.2	V
ESD Tolerance		HBM	—	—	2	kV
		CDM	—	—	1.25	kV
		MM	—	—	250	V

Notes:

1. Absolute maximum ratings are stress ratings only, operation at or beyond these conditions is not implied and may shorten the life of the device or alter its performance.
2. Special handling considerations apply; see application note, "AN607: Si70xx Humidity Sensor Designer's Guide" for details.

2. Typical Application Circuits

The primary function of the Si7013 is to measure relative humidity and temperature. Figure 4 demonstrates the typical application circuit to achieve these functions; pins 6 and 7 are not required and should be left unconnected.

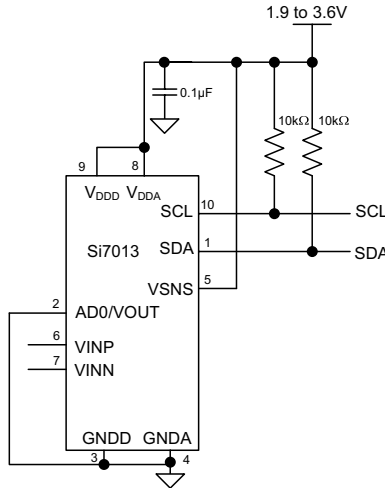

Figure 4. Typical Application Circuit for Relative Humidity and Temperature Measurement

The application circuit shown in Figure 5 uses the auxiliary analog pins for measuring a remote temperature using a thermistor.

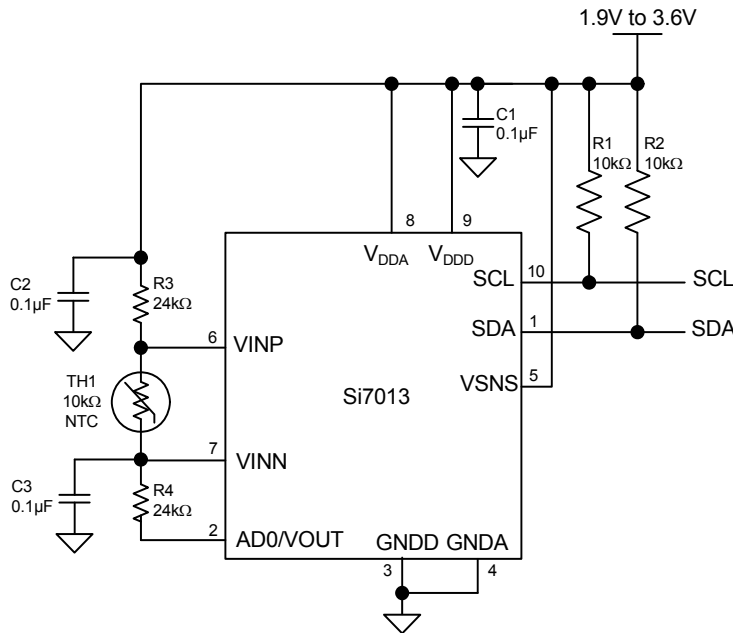

Figure 5. Typical Application Circuit for Thermistor Interface with AD0 = 1

The voltage connected at VDDA serves as the reference voltage for both the Analog-to-Digital converter and the resistor string. Therefore, the ADC must be configured to take its reference from VDDA. The top of the resistor string is connected to the VOUT pin, allowing the resistor string to be powered down, saving power between temperature conversions. In this mode of operation, the analog inputs are buffered and present an input impedance of > 100 kΩ.

The AD0/VOUT pin is a dual function pin. At powerup, it functions as an address select pin and selects the least significant I²C Figure 5, the AD0/VOUT pin is pulled high, selecting AD0 = 1. In Figure 6, the AD0/VOUT pin is pulled low selecting AD0 = 0.

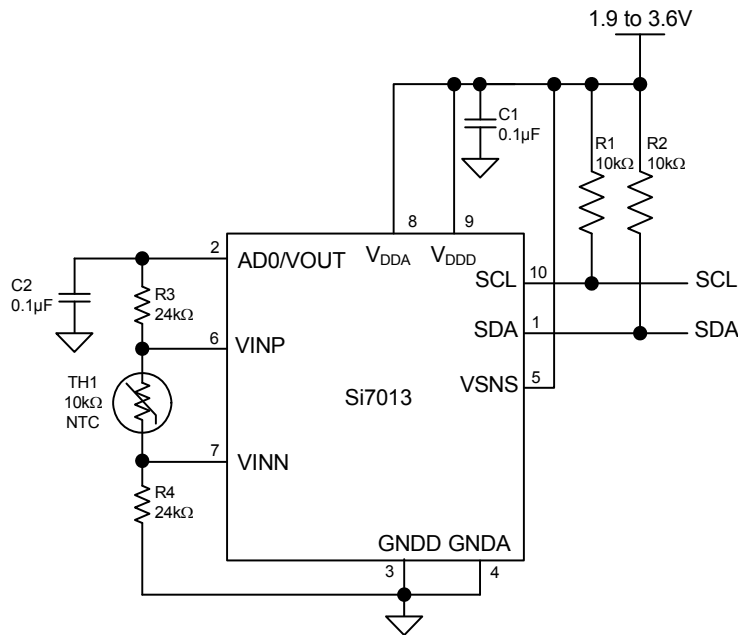

Figure 6. Typical Application Circuit for Thermistor Interface with AD0 = 0

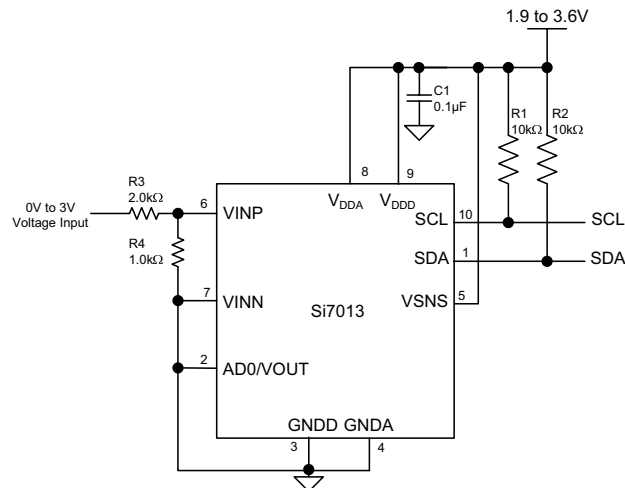

Figure 7. Typical Application Circuit for Single Ended 0 to 3 V Measurement

Figure 7 demonstrates a single ended 0 to 3 V input range configuration. The voltage reference is the internal 1.25 V reference. The 1 kΩ and 2 kΩ resistor divider keeps the voltage range to 1.0 V, which is within the recommended 80% of V_{REF} . Full scale of 32767 counts is 3.75 V.

Si7013-A10

3. Bill of Materials

Table 9. Typical Application Circuit BOM for Relative Humidity and Temperature Measurement

Reference	Description	Mfr Part Number	Manufacturer
R1	Resistor, 10 k Ω , \pm 5%, 1/16W, 0603	CR0603-16W-103JT	Venkel
R2	Resistor, 10 k Ω , \pm 5%, 1/16W, 0603	CR0603-16W-103JT	Venkel
C1	Capacitor, 0.1 μ F, 16 V, X7R, 0603	C0603X7R160-104M	Venkel
U1	IC, Digital Temperature/humidity Sensor	Si7013-A10	Silicon Labs

Table 10. Typical Application Circuit BOM for Thermistor Interface

Reference	Description	Mfr Part Number	Manufacturer
R1	Resistor, 10 k Ω , \pm 5%, 1/16W, 0603	CR0603-16W-103JT	Venkel
R2	Resistor, 10 k Ω , \pm 5%, 1/16W, 0603	CR0603-16W-103JT	Venkel
R3	Resistor, 24 k Ω , \pm 1%, 1/16W, 0603	CR0603-16W-2402F	Venkel
R4	Resistor, 24 k Ω , \pm 1%, 1/16W, 0603	CR0603-16W-2402F	Venkel
C1	Capacitor, 0.1 μ F, 16 V, X7R, 0603	C0603X7R160-104M	Venkel
C2	Capacitor, 0.1 μ F, 16 V, X7R, 0603	C0603X7R160-104M	Venkel
TH1	Thermistor, 10 k Ω	NTCLE100E3103	Vishay
U1	IC, digital temperature/humidity sensor	Si7013-A10	Silicon Labs

Table 11. Typical Application Circuit BOM for Single Ended 0 to 3 V Measurement

Reference	Description	Mfr Part Number	Manufacturer
R1	Resistor, 10 k Ω , \pm 5%, 1/16W, 0603	CR0603-16W-103JT	Venkel
R2	Resistor, 10 k Ω , \pm 5%, 1/16W, 0603	CR0603-16W-103JT	Venkel
R3	Resistor, 2 k Ω , \pm 1%, 1/16W, 0603	CR0603-16W-2001F	Venkel
R4	Resistor, 1 k Ω , \pm 1%, 1/16W, 0603	CR0603-16W-1001F	Venkel
C1	Capacitor, 0.1 μ F, 16 V, X7R, 0603	C0603X7R160-104M	Venkel
U1	IC, Digital Temperature/humidity Sensor	Si7013-A10	Silicon Labs

4. Functional Description

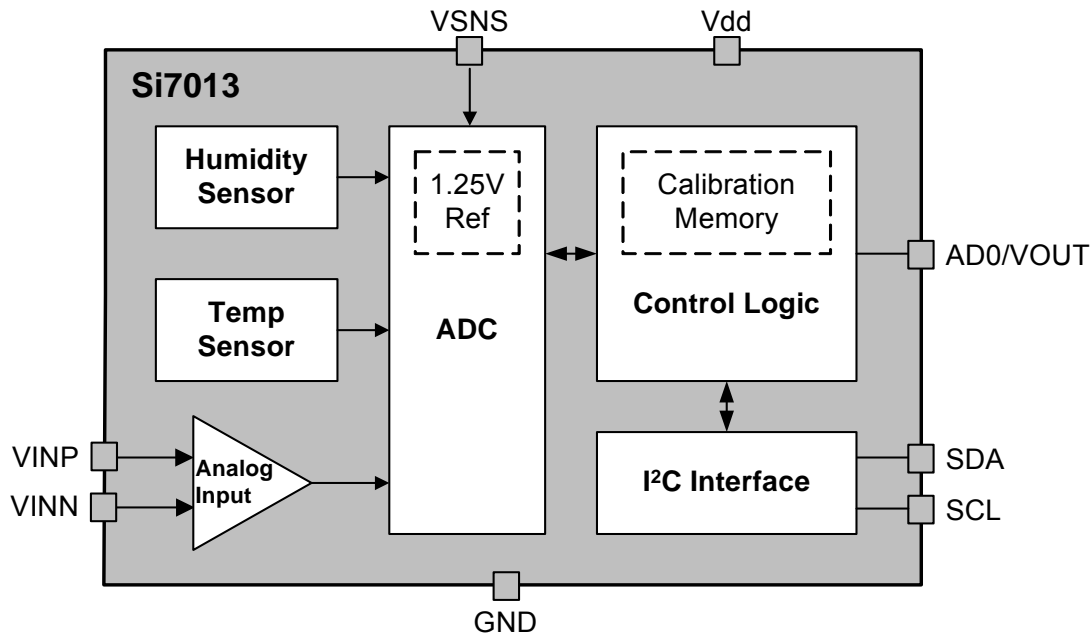

Figure 8. Si7013 Block Diagram

The Si7013 is a digital relative humidity and temperature sensor that integrates temperature and humidity sensor elements, an analog-to-digital converter, signal processing, calibration, polynomial non-linearity correction, and an I²C interface all in a single chip. The Si7013 is individually factory-calibrated for both temperature and humidity, with the calibration data stored in on-chip non-volatile memory. This ensures that the sensor is fully interchangeable, with no recalibration or changes to software required. Patented use of industry-standard CMOS and low-K dielectrics as a sensor enables the Si7013 to achieve excellent long term stability and immunity to contaminants with low drift and hysteresis. The Si7013 offers a low power, high accuracy, calibrated and stable solution ideal for a wide range of temperature, humidity, and dew-point applications including medical and instrumentation, high reliability automotive and industrial systems, and cost-sensitive consumer electronics.

The auxiliary sensor input option exists to use the ADC with external inputs and reference. Suitable buffers are included to allow the part to be connected to high impedance circuitry such as bridges or other types of sensors, without introducing errors.

While the Si7013 is largely a conventional mixed-signal CMOS integrated circuit, relative humidity sensors in general and those based on capacitive sensing using polymeric dielectrics have unique application and use requirements that are not common to conventional (non-sensor) ICs. Chief among those are:

- The need to protect the sensor during board assembly, i.e., solder reflow, and the need to subsequently rehydrate the sensor.
- The need to protect the sensor from damage or contamination during the product life-cycle.
- The impact of prolonged exposure to extremes of temperature and/or humidity and their potential effect on sensor accuracy.
- The effects of humidity sensor “memory”.

Each of these items is discussed in more detail in the following sections.

4.1. Relative Humidity Sensor Accuracy

To determine the accuracy of a relative humidity sensor, it is placed in a temperature and humidity controlled chamber. The temperature is set to a convenient fixed value (typically 25–30 °C) and the relative humidity is swept from 20 to 80% and back to 20% in the following steps: 20% – 40% – 60% – 80% – 80% – 60% – 40% – 20%. At each set-point, the chamber is allowed to settle for a period of 60 minutes before a reading is taken from the sensor. Prior to the sweep, the device is allowed to stabilize to 50%RH. The solid trace in Figure 9 shows the result of a typical sweep.

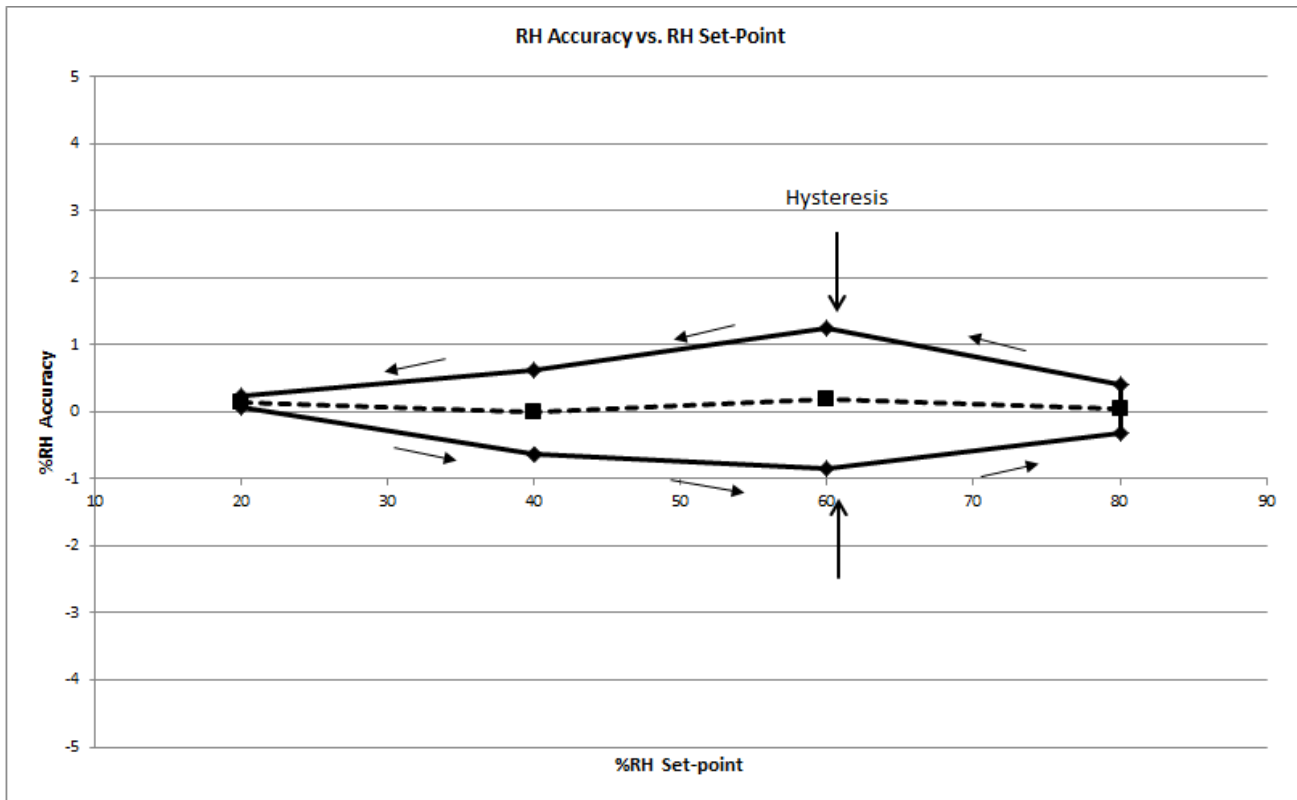

Figure 9. Measuring Sensor Accuracy Including Hysteresis

The RH accuracy is defined as the dotted line shown in Figure 9, which is the average of the two data points at each relative humidity set-point. In this case, the sensor shows an accuracy of 0.25%RH. The Si7013 accuracy specification (Table 4) includes:

- Unit-to-unit and lot-to-lot variation
- Accuracy of factory calibration
- Margin for shifts that can occur during solder reflow

The accuracy specification does not include:

- Hysteresis (typically $\pm 1\%$)
- Effects from long term exposure to very humid conditions
- Contamination of the sensor by particulates, chemicals, etc.
- Other aging related shifts ("Long-term stability")
- Variations due to temperature

4.2. Hysteresis

The moisture absorbent film (polymeric dielectric) of the humidity sensor will carry a memory of its exposure history, particularly its recent or extreme exposure history. A sensor exposed to relatively low humidity will carry a negative offset relative to the factory calibration, and a sensor exposed to relatively high humidity will carry a positive offset relative to the factory calibration. This factor causes a hysteresis effect illustrated by the solid trace in Figure 9. The hysteresis value is the difference in %RH between the maximum absolute error on the decreasing humidity ramp and the maximum absolute error on the increasing humidity ramp at a single relative humidity setpoint and is expressed as a bipolar quantity relative to the average error (dashed trace). In the example of Figure 9, the measurement uncertainty due to the hysteresis effect is +/-1.0%RH.

4.3. Prolonged Exposure to High Humidity

Prolonged exposure to high humidity will result in a gradual upward drift of the RH reading. The shift in sensor reading resulting from this drift will generally disappear slowly under normal ambient conditions. The amount of shift is proportional to the magnitude of relative humidity and the length of exposure. In the case of lengthy exposure to high humidity, some of the resulting shift may persist indefinitely under typical conditions. It is generally possible to substantially reverse this affect by baking the device (see Section “4.6. Bake/Hydrate Procedure”).

4.4. PCB Assembly

4.4.1. Soldering

Like most ICs, Si7013 devices are shipped from the factory vacuum-packed with an enclosed desiccant to avoid any drift during storage and to prevent any moisture-related issues during solder reflow. The following guidelines should be observed during PCB assembly:

- Si7013 devices are compatible with standard board assembly processes. Devices should be soldered using reflow per the recommended card reflow profile. See Section “10. PCB Land Pattern and Solder Mask Design” for the recommended card reflow profile.
- A “no clean” solder process is recommended to minimize the need for water or solvent rinses after soldering. Cleaning after soldering is possible, but must be done carefully to avoid impacting the performance of the sensor. See application note “AN607: Si70xx Humidity Sensor Designer’s Guide” for more information on cleaning.
- It is essential that the exposed polymer sensing film be kept clean and undamaged. This can be accomplished by careful handling and a clean, well-controlled assembly process. When in doubt or for extra protection, a heat-resistant, protective cover such as Kapton[®] KPPD-1/8 can be installed during PCB assembly.

Si7013s may be ordered with a factory-fitted, solder-resistant protective cover. This cover provides protection during PCB assembly or rework but without the time and effort required to install and remove the Kapton tape. It can be left in place for the lifetime of the product, preventing liquids, dust or other contaminants from coming into contact with the polymer sensor film. See Section “8. Ordering Guide” for a list of ordering part numbers that include the cover.

4.4.2. Rehydration

The measured humidity value will generally shift slightly after solder reflow. A portion of this shift is permanent and is accounted for in the accuracy specifications in Table 4. After soldering, an Si7013 should be allowed to equilibrate under controlled RH conditions (room temperature, 45–55%RH) for at least 48 hours to eliminate the remainder of the shift and return the device to its specified accuracy performance.

Si7013-A10

4.4.3. Rework

To maintain the specified sensor performance, care must be taken during rework to minimize the exposure of the device to excessive heat and to avoid damage/contamination or a shift in the sensor reading due to liquids, solder flux, etc. Manual touch-up using a soldering iron is permissible under the following guidelines:

- The exposed polymer sensing film must be kept clean and undamaged. A protective cover is recommended during any rework operation (Kapton® tape or the factory installed cover).
- Flux must not be allowed to contaminate the sensor; liquid flux is not recommended even with a cover in place. Conventional lead-free solder with rosin core is acceptable for touch-up as long as a cover is in place during the rework.
- If possible, avoid water or solvent rinses after touch-up. Cleaning after soldering is possible, but must be done carefully to avoid impacting the performance of the sensor. See AN607 for more information on cleaning.
- Minimize the heating of the device. Soldering iron temperatures should not exceed 350 °C and the contact time per pin should not exceed 5 seconds.
- Hot air rework is not recommended. If a device must be replaced, remove the device by hot air and solder a new part in its place by reflow following the guidelines above.

***Note:** All trademarks are the property of their respective owners.

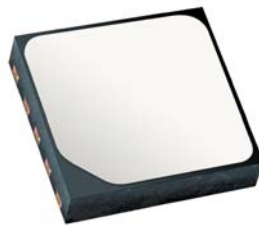

Figure 10. Si70xx with Factory-Installed Protective Cover

4.5. Protecting the Sensor

Because the sensor operates on the principal of measuring a change in capacitance, any changes to the dielectric constant of the polymer film will be detected as a change in relative humidity. Therefore, it is important to minimize the probability of contaminants coming into contact with the sensor. Dust and other particles as well as liquids can affect the RH reading. It is recommended that a cover is employed in the end system that blocks contaminants but allows water vapor to pass through. Depending on the needs of the application, this can be as simple as plastic or metallic gauze for basic protection against particulates or something more sophisticated such as a hydrophobic membrane providing up to IP67 compliant protection.

The Si7013 may be ordered with a factory-fitted, solder-resistant cover that can be left in place for the lifetime of the product. It is very low-profile, hydrophobic and oleophobic, and excludes particulates down to 0.35 microns in size. See Section “8. Ordering Guide” for a list of ordering part numbers that include the cover. A dimensioned drawing of the IC with the cover is included in Section “9. Package Outline”. Other characteristics of the cover are listed in Table 12.

Table 12. Specifications of Protective Cover

Parameter	Value
Material	ePTFE
Water Entry Pressure	2.7 bar
Pore Size	0.35 μ
Operating Temperature	-40 to 125 °C
Maximum Reflow Temperature	260 °C
Oleophobicity (AATCC 118-1992)	7
IP Rating (per IEC 529)	IP67

4.6. Bake/Hydrate Procedure

After exposure to extremes of temperature and/or humidity for prolonged periods, the polymer sensor film can become either very dry or very wet; in each case the result is either high or low relative humidity readings. Under normal operating conditions, the induced error will diminish over time. From a very dry condition, such as after shipment and soldering, the error will diminish over a few days at typical controlled ambient conditions, e.g., 48 hours of $45 \leq \%RH \leq 55$. However, from a very wet condition, recovery may take significantly longer. To accelerate recovery from a wet condition, a bake and hydrate cycle can be implemented. This operation consists of the following steps:

- Baking the sensor at 125 °C for ≥ 12 hours
- Hydration at 30 °C in 75% RH for ≥ 10 hours

Following this cycle, the sensor will return to normal operation in typical ambient conditions after a few days.

4.7. Long Term Drift/Aging

Over long periods of time, the sensor readings may drift due to aging of the device. Standard accelerated life testing of the Si7013 has resulted in the specifications for long-term drift shown in Table 4 and Table 5. This contribution to the overall sensor accuracy accounts only for the long-term aging of the device in an otherwise benign operating environment and does not include the effects of damage, contamination, or exposure to extreme environmental conditions.

5. I²C Interface

The Si7013 communicates with the host controller over a digital I²C interface. The 7-bit base slave address is 0x40 or 0x41; the least significant bit is pin programmable.

Table 13. I²C Slave Address Byte

A6	A5	A4	A3	A2	A1	A0	R/W
1	0	0	0	0	0	AD0	1/0

Master I²C devices communicate with the Si7013 using a command structure. The commands are listed in the I²C command table. Commands other than those documented below are undefined and should not be sent to the device.

Table 14. I²C Command Table

Command Description	Command Code
Measure Relative Humidity, Hold Master Mode	0xE5
Measure Relative Humidity, No Hold Master Mode	0xF5
Measure Temperature, Hold Master Mode	0xE3
Measure Temperature, No Hold Master Mode	0xF3
Measure Analog Voltage or Thermistor Temperature	0xEE
Read Temperature Value from Previous RH Measurement	0xE0
Reset	0xFE
Write Voltage Measurement Setup (User register 2)	0x50
Read Voltage Measurement Setup (User register 2)	0x10
Write RH/T Measurement Setup (User register 1)	0xE6
Read RH/T Measurement Setup (User register 1)	0xE7
Write Heater Setup (User register 3)	0x51
Read Heater Setup (User register 3)	0x11
Write Thermistor Correction Coefficient	0xC5
Read Thermistor Correction Coefficient	0x84
Read Electronic ID 1st Word	0xFA 0x0F
Read Electronic ID 2nd Word	0xFC 0xC9
Read Firmware Revision	0x84 0xB8

5.1. Issuing a Measurement Command

The measurement commands instruct the Si7013 to perform one of four possible measurements; Relative Humidity, Temperature, Auxiliary Temperature, or Analog Voltage. While the measurement is in progress, the option of either clock stretching (Hold Master Mode) or Not Acknowledging read requests (No Hold Master Mode) is available to indicate to the master that the measurement is in progress. For Humidity and Temperature measurements, the chosen command code determines which mode is used. For Auxiliary Temperature and Analog Voltage measurements, No Hold Master mode can be enabled by writing a "1" to bit D6 in register 2. Note that internal Humidity and Temperature measurements should not be made with this bit set.

Optionally, a checksum byte can be returned from the slave for use in checking for transmission errors for Relative Humidity and Temperature measurements. The checksum byte is optional after initiating an RH or temperature measurement with commands 0xE5, 0xF5, 0xE3 and 0xF3. The checksum byte is required for reading the electronic ID with commands 0xFA 0x0F and 0xFC 0xC9. For all other commands, the checksum byte is not supported. The checksum byte will follow the least significant measurement byte if it is acknowledged by the master. The checksum byte is not returned if the master "not acknowledges" the least significant measurement byte. The checksum byte is calculated using a CRC generator polynomial of $x^8 + x^5 + x^4 + 1$ with an initialization of 0x00.

Sequence to perform a measurement and read back result (Hold Master Mode)

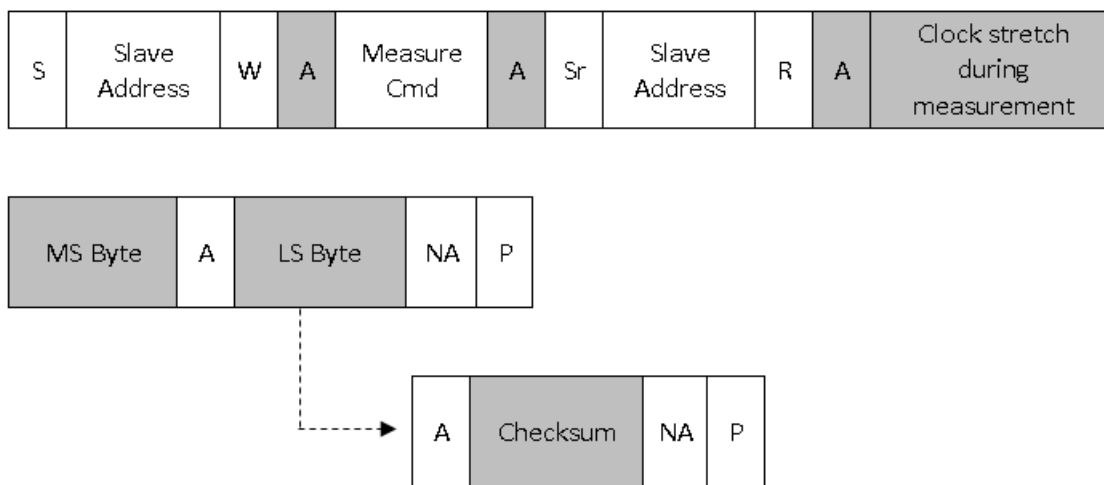

Sequence to perform a measurement and read back result (No Hold Master Mode)

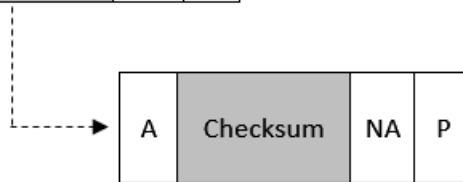
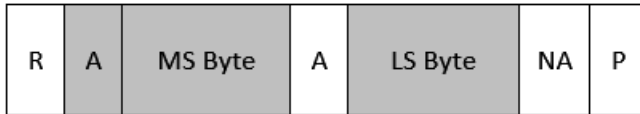
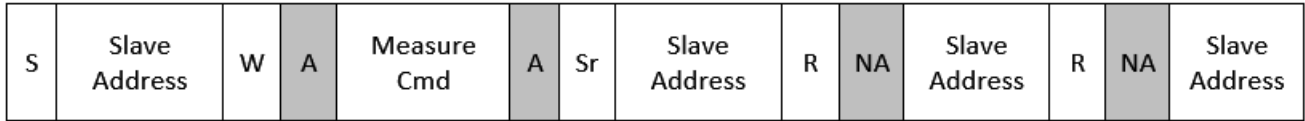

Si7013-A10

5.1.1. Measuring Relative Humidity

Once a relative humidity measurement has been made, the results of the measurement may be converted to percent relative humidity by using the following expression:

$$\%RH = \frac{125 * RH_Code}{65536} - 6$$

Where:

%RH is the measured relative humidity value in %RH

RH Code is the 16-bit word returned by the Si7013

A humidity measurement will always return XXXXXX10 in the LSB field.

Note: Due to normal variations in RH accuracy of the device as described in Table 4, it is possible for the measured value of %RH to be slightly less than 0 when the actual RH level is close to or equal to 0. Similarly, the measured value of %RH may be slightly greater than 100 when the actual RH level is close to or equal to 100. This is expected behavior, and it is acceptable to limit the range of RH results to 0 to 100%RH in the host software by truncating values that are slightly outside of this range.

5.1.2. Measuring Temperature

Each time a relative humidity measurement is made a temperature measurement is also made for the purposes of temperature compensation of the relative humidity measurement. If the temperature value is required, it can be read using command 0xE0; this avoids having to perform a second temperature measurement. The measure temperature commands 0xE3 and 0xF3 will perform a temperature measurement and return the measurement value, command 0xE0 does not perform a measurement but returns the temperature value measured during the relative humidity measurement. The checksum output is not available with the 0xE0 command.

Sequence to read temperature value from previous RH measurement

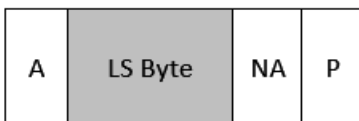
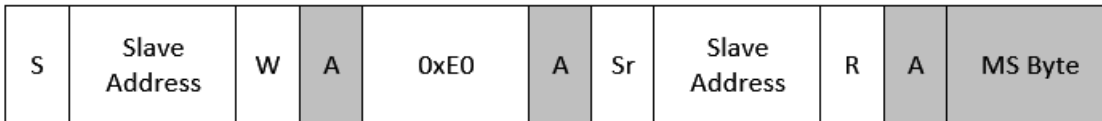

The results of the temperature measurement may be converted to temperature in degrees Celsius (°C) using the following expression:

$$\text{Temperature (}^\circ\text{C)} = \frac{175.72 * \text{Temp_Code}}{65536} - 46.85$$

Where:

Temperature (°C) is the measured temperature value in °C

Temp_Code is the 16-bit word returned by the Si7013

A temperature measurement will always return XXXXXX00 in the LSB field.

5.2. Reading and Writing User Registers

There are three user registers on the Si7013 that allow the user to set the configuration of the Si7013, the procedure for accessing these registers is set out below. The checksum byte is not supported after reading a user register.

Sequence to read a register

S	Slave Address	W	A	Read Reg Cmd	A	Sr	Slave Address	R	A	Read Data	NA	P
---	---------------	---	---	--------------	---	----	---------------	---	---	-----------	----	---

Sequence to write a register

S	Slave Address	W	A	Write Reg Cmd	A	Write Data	A	P
---	---------------	---	---	---------------	---	------------	---	---

5.3. Measuring Analog Voltage

The analog voltage input pins can accept voltage inputs within the ranges shown in Table 15. V_{REFP} is internally connected to V_{DDA} or to an internal 1.25 V reference voltage.

Table 15. Analog Input Ranges

	V_{INP} Input Range		V_{INN} Input Range	
	Min	Max	Min	Max
Buffered Input	0.35 V	$V_{DD}-0.35$ V	0.35 V	$V_{DD}-0.35$ V
Unbuffered Input	0 V	VDD	0 V	VDD

The voltage conversion output is a signed 16-bit integer that will vary from -32768 to 32767 as the input ($V_{INP}-V_{INN}$) goes from $-V$ to $+V$. For best performance, it is recommended that $|V_{INP}-V_{INN}|$ be limited to $V_{ref}/2$. With minor degradation in performance, this can be extended to $0.8 \cdot V_{ref}$. The checksum option for voltage mode conversions is not supported.

5.4. Nonlinear Correction of Voltage Inputs:

The Si7013 contains a look-up table for applying non-linear correction to external voltage measurements. The look-up table is contained in an internal, user-programmable OTP memory. The OTP memory is non-volatile, meaning the values are retained even when the device is powered off.

Once the lookup table values have been programmed, this correction is invoked by writing a “1” to bit 5 of user register 2. Note that humidity measurements should not be performed when this bit is set.

5.4.1. Calculating Lookup Table Values

The non-linear correction is based on 10 points. Each point consists of the ideal output for a given expected A/D measurement result.

Values between the ideal output points are interpolated based on the slope between the two output points.

The lookup table is stored in the Si7013 memory. Values must be programmed for each pair of input values and ideal output points. In addition, the slope between each ideal output point must also be programmed (the Si7013 will not automatically calculate the slope). Only 9 of the input/output pairs need to be in the table because the 10th output value is determined by the slope equation.

The table contains 3 sets of 9 values:

- In(1-9): 16-bit signed values for each input point read from the ADC. See Section “5.3. Measuring Analog Voltage” for more information on setting up the ADC measurement.
- Out(1-9): 16-bit unsigned values for each ideal output point that should be used for each input point.
- Slope(1-9): 16-bit signed values for the slope between each ideal output point.

Note: The table must be arranged in order of decreasing input values.

The slope values must be calculated as follows:

$$\text{slope}_N = 256 * (\text{output}_{N+1} - \text{output}_N) / (\text{input}_{N+1} - \text{input}_N)$$

The actual output value is determined by extrapolation:

If $\text{in} > \text{in}_2$, $\text{out} = \text{out}_1 + \text{slope}_1 * (\text{in} - \text{in}_1) / 256$

Else if $\text{in} > \text{in}_3$, $\text{out} = \text{out}_2 + \text{slope}_2 * (\text{in} - \text{in}_2) / 256$

Else if $\text{in} > \text{in}_4$, $\text{out} = \text{out}_3 + \text{slope}_3 * (\text{in} - \text{in}_3) / 256$

Else if $\text{in} > \text{in}_5$, $\text{out} = \text{out}_4 + \text{slope}_4 * (\text{in} - \text{in}_4) / 256$

Else if $\text{in} > \text{in}_6$, $\text{out} = \text{out}_5 + \text{slope}_5 * (\text{in} - \text{in}_5) / 256$

Else if $\text{in} > \text{in}_7$, $\text{out} = \text{out}_6 + \text{slope}_6 * (\text{in} - \text{in}_6) / 256$

Else if $\text{in} > \text{in}_8$, $\text{out} = \text{out}_7 + \text{slope}_7 * (\text{in} - \text{in}_7) / 256$

Else if $\text{in} > \text{in}_9$, $\text{out} = \text{out}_8 + \text{slope}_8 * (\text{in} - \text{in}_8) / 256$

Else $\text{out} = \text{out}_9 + \text{slope}_9 * (\text{in} - \text{in}_9)$

5.4.2. Entering Lookup Table Values into OTP Memory:

The table is entered into memory addresses 0x82 – 0xB7 one byte at a time. Until the OTP has been programmed, all memory addresses default to a value of 0xFF. The table below indicates where the values are written:

Table 16. Lookup Table Memory Map

Name	Memory Location	Name	Memory Location	Name	Memory Location
Input1 (MSB)	0x82	Output1 (MSB)	0x94	Slope1 (MSB)	0xA6
Input1 (LSB)	0x83	Output1 (LSB)	0x95	Slope1 (LSB)	0xA7
Input2 (MSB)	0x84	Output2 (MSB)	0x96	Slope2 (MSB)	0xA8
Input2 (LSB)	0x85	Output2 (LSB)	0x97	Slope2 (LSB)	0xA9
Input3 (MSB)	0x86	Output3 (MSB)	0x98	Slope3 (MSB)	0xAA
Input3 (LSB)	0x87	Output3 (LSB)	0x99	Slope3 (LSB)	0xAB
Input4 (MSB)	0x88	Output4 (MSB)	0x9A	Slope4 (MSB)	0xAC
Input4 (LSB)	0x89	Output4 (LSB)	0x9B	Slope4 (LSB)	0xAD
Input5 (MSB)	0x8A	Output5 (MSB)	0x9C	Slope5 (MSB)	0xAE
Input5 (LSB)	0x8B	Output5 (LSB)	0x9D	Slope5 (LSB)	0xAF
Input6 (MSB)	0x8C	Output6 (MSB)	0x9E	Slope6 (MSB)	0xB0
Input6 (LSB)	0x8D	Output6 (LSB)	0x9F	Slope6 (LSB)	0xB1
Input7 (MSB)	0x8E	Output7 (MSB)	0xA0	Slope7 (MSB)	0xB2
Input7 (LSB)	0x8F	Output7 (LSB)	0xA1	Slope7 (LSB)	0xB3
Input8 (MSB)	0x90	Output8 (MSB)	0xA2	Slope8 (MSB)	0xB4
Input8 (LSB)	0x91	Output8 (LSB)	0xA3	Slope8 (LSB)	0xB5
Input9 (MSB)	0x92	Output9 (MSB)	0xA4	Slope9 (MSB)	0xB6
Input9 (LSB)	0x93	Output9 (LSB)	0xA5	Slope9 (LSB)	0xB7

Si7013-A10

The sequences for reading and writing thermistor coefficients are given below:

Sequence to write thermistor correction coefficients

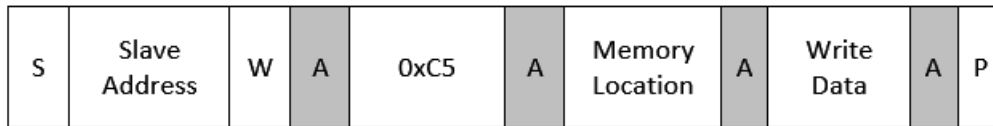

Sequence to read thermistor correction coefficients

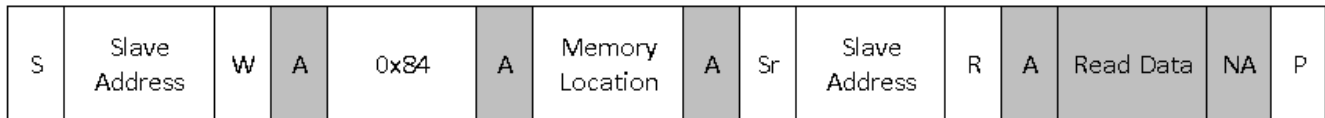

For example, to program a Si7013 at slave address 0x40 with the 16-bit value 0x4C2F, starting at memory location 0x82, you would write:

<Start Condition> 0x40 W ACK 0xC5 ACK 0x82 ACK 0x4C ACK <Stop Condition>

<Start Condition> 0x40 W ACK 0xC5 ACK 0x83 ACK 0x2F ACK <Stop Condition>

The internal memory is one-time-programmable, so it is not possible to change the values once written. However, to verify the values were written properly use command 0x84. For example, to verify that 0x4C was written to location 0x82 use

<Start Condition> 0x40 W ACK 0x84 ACK 0x82 ACK <Start Condition> 0x40 R ACK 0x4C NACK <Stop Condition> where 0x4C is the expected return value of the read transaction.

5.4.3. Example Thermistor Calculations

For the Si7013 evaluation board with a 10 K ohm thermistor and two 24.3 K ohm bias resistors and assuming the A/D conversion is done using V_{DD} as a reference with buffered inputs, the ideal input voltage versus temperature is:

$$V_{in} = V_{DD} * R_{thermistor} / (R_{thermistor} + 46.4 \text{ K})$$

Since V_{DD} is also the reference then the expected A/D conversion result is:

$$\text{A/D counts} = 32768 * R_{thermistor} / (R_{thermistor} + 46.4 \text{ K})$$

If it is desired to linearize this result for the same temperature representation as the on board temperature sensor:

$$\text{Temperature } ^\circ\text{C} = (\text{Output_Code} * 175.72 / 65536 - 46.85), \text{ then the desired output code is:}$$

$$\text{Output_Code} = 65536 * (\text{Temperature} + 46.85) / 175.72$$

Using thermistor data sheet values of resistance versus temperature and choosing to linearize at the points -15C, -5C, 5C, 15C, 25C, 35C, 45C, 55C, 65C and 75C results in the following. The values in gray are the table entries for Si7013:

Table 17. Example Non-Linear Correction to Thermistor Voltage Measurements

Temperature (Degrees C)	Thermistor Resistance	Vin/VDD	A/D Codes	Desired Code	Slope	Table Entry
-15	71746	0.596164	19535	11879	-218	1
-5	41813	0.462467	15154	15608	-241	2
5	25194	0.34141	11187	19338	-298	3
15	15651	0.243592	7982	23067	-400	4
25	10000	0.170648	5592	26797	-563	5
35	6556	0.118863	3895	30527	-813	6
45	4401	0.83036	2721	34256	-1186	7
55	3019	0.058486	1916	37986	-1739	8
65	2115	0.041704	1367	41715	-2513	9
75	1509	0.030114	75	45445		

Si7013-A10

Once the table entry values are calculated, they should be programmed to the Si7013 memory locations as shown below:

Table 18. Example Non-Linear Thermistor Correction Entries into Si7013 Memory

Memory Location	A/D Codes	Value	Memory Location	Desired Codes	Value	Memory Location	Slope	Value
82	19535	4C	94	11879	2E	A6	-218	FF
83		4F	95		67	A7		26
84	15154	3B	96	15608	3C	A8	-241	FF
85		32	97		F8	A9		0F
86	11187	2B	98	19338	4B	AA	-298	FE
87		B3	99		8A	AB		D6
88	7982	1F	9A	23067	5A	AC	-400	FE
89		2E	9B		1B	AD		70
8A	5592	15	9C	26797	68	AE	-563	FD
8B		D8	9D		Ad	AF		CD
8C	3895	F	9E	30527	77	B0	-813	FC
8D		37	9F		3F	B1		D3
8E	2721	A	A0	34256	85	B2	-1186	FB
8F		A1	A1		D0	B3		5E
90	1916	7	A2	37986	94	B4	-1739	F9
91		7C	A3		62	B5		35
92	1367	5	A4	41715	A2	B6	-2513	F6
93		57	A5		F3	B7		2F

5.5. Firmware Revision

The internal firmware revision can be read with the following I2C transaction:

S	Slave Address	W	A	0x84	A	0xB8	A	S	Slave Address
---	---------------	---	---	------	---	------	---	---	---------------

R	A	FWREV	A	NA	P
---	---	-------	---	----	---

The values in this field are encoded as follows:

0xFF = Firmware revision 1.0

5.6. Heater

The Si7013 contains an integrated resistive heating element that may be used to raise the temperature of the sensor. This element can be used to test the sensor, to drive off condensation, or to implement dew-point measurement when the Si7013 is used in conjunction with a separate temperature sensor such as another Si7013 (the heater will raise the temperature of the internal temperature sensor).

The heater can be activated using HEATER[2:0], the three least-significant bits in User Register 3. Turning on the heater will reduce the tendency of the humidity sensor to accumulate an offset due to "memory" of sustained high humidity conditions. Five different power levels are available. The various settings are described in Table 18.

Table 19. Heater Control Settings

HEATER[3:0]	Typical Current Draw* (mA)
0000	3.09
0001	9.18
0010	15.24
...	...
0100	27.39
...	...
1000	51.69
...	...
1111	94.20
*Note: Assumes VDD = 3.3 V.	

Si7013-A10

5.7. Electronic Serial Number

The Si7013 provides a serial number individualized for each device that can be read via the I²C serial interface.

Two I²C commands are required to access the device memory and retrieve the complete serial number. The command sequence, and format of the serial number response is described in the figure below:



First access:

S	Slave Address	W	ACK	0x3A	ACK	0X0F	ACK		
S	Slave Address	R	ACK						
	SNA_3	ACK	CRC	ACK	SNA_2	ACK	CRC	ACK	
	SNA_1	ACK	CRC	ACK	SNA_0	ACK	CRC	NACK	P

2nd access:

S	Slave Address	W	ACK	0x3C	ACK	0X09	ACK		
S	Slave Address	R	ACK						
	SNB_3	ACK	SNB_2	ACK	CRC	ACK			
	SNB_1	ACK	SNB_0	ACK	CRC	NACK	P		

The format of the complete serial number is 64-bits in length, divided into 8 data bytes. The complete serial number sequence is shown below:

SNA_3	SNA_2	SNA_1	SNA_0	SNB_3	SNB_2	SNB_1	SNB_0
-------	-------	-------	-------	-------	-------	-------	-------

The SNB3 field contains the device identification to distinguish between the different Silicon Labs relative humidity and temperature devices. The value of this field maps to the following devices according to this table:

0x00 or 0xFF engineering samples

0x0D=13=Si7013

0x14=20=Si7020

0x15=21=Si7021

6. Control Registers

Table 20. Register Summary

Register	Bit 7	Bit 6	Bit 5	Bit 4	Bit 3	Bit 2	Bit 1	Bit 0
User Register 1	RES1	VDDS	RSVD			HTRE	RSVD	RES0
User Register 2		NO_HOLD	THERM_CORR	CONV_TIME	RSVD	VIN_BUF	VREFP	VOUT
User Register 3	RSVD				HEATER[3:0]			

Notes:

1. Any register not listed here is reserved and must not be written. The result of a read operation on these registers is undefined.
2. Except where noted, reserved register bits always read back as "1", and are not affected by write operations. For future compatibility, it is recommended that prior to a write operation, registers should be read. Then the values read from the RSVD bits should be written back unchanged during the write operation.

Si7013-A10

6.1. Register Descriptions

Register 1. User Register 1

Bit	D7	D6	D5	D4	D3	D2	D1	D0
Name	RES1	VDDS	RSVD			HTRE	RSVD	RES0
Type	R/W	R	R/W			R/W	R/W	R/W

Reset Settings = 0011_1010

Bit	Name	Function
D7; D0	RES[1:0]	Measurement Resolution: RH Temp 00: 12 bit 14 bit 01: 8 bit 12 bit 10: 10 bit 13 bit 11: 11 bit 11 bit
D6	VDDS	VDD Status: 0: V _{DD} OK 1: V _{DD} Low The minimum recommended operating voltage is 1.9 V. A transition of the VDD status bit from 0 to 1 indicates that VDD is between 1.8 V and 1.9 V. If the VDD drops below 1.8 V, the device will no longer operate correctly.
D5, D4, D3	RSVD	Reserved
D2	HTRE	1=On-chip Heater Enable 0=On-chip Heater Disable
D1	RSVD	Reserved

Register 2. User Register 2

Bit	D7	D6	D5	D4	D3	D2	D1	D0
Name	RSVD	NO_HOLD	THERM_CORR	CONV_TIME	RSVD	VIN_BUF	VREFP	VOUT
Type	R/W	R/W	R/W	R/W	R/W	R/W	R/W	R/W

Reset Settings = 0000_100x

Bit	Name	Function
D7	RSVD	Reserved
D6	NO_HOLD	1: Auxiliary voltage and thermistor measurements made in No Hold Master Mode. Note that this bit must be set to "0" before initiating an internal temperature or humidity measurement. 0: Auxiliary voltage and thermistor measurements made in Hold Master Mode.
D5	THERM_CORR	1: Thermistor correction enabled for auxiliary voltage and thermistor measurements. Note that this bit must be set to "0" before initiating an internal temperature or humidity measurement. 0: Thermistor correction disabled.
D4	CONV_TIME	Conversion Time. Selects conversion time and noise floor of the voltage ADC. 0: Normal mode 1: Fast mode
D3	RSVD	Reserved
D2	VIN_BUF	0: VINN and VINP inputs are unbuffered 1: VINN and VINP inputs are buffered
D1	VREFP	0: A/D reference source is internal 1.25V 1: A/D reference source is VDDA
D0	VOUT*	0: VOUT pin is set to GNDD 1: VOUT pin is set to VDDD Note: Default is powerup state of VOUT pin
* Note: VOUT is generally used for driving an external thermistor interface. Default setting is the same as the power up setting.		

Si7013-A10

Register 3. User Register 3

Bit	D7	D6	D5	D4	D3	D2	D1	D0
Name	RSVD				Heater [3:0]			
Type	R/W				R/W			

Reset Settings = 0000_0000

Bit	Name	Function				
D3:D0	HEATER[3:0]	D3	D2	D1	D0	Heater Current
		0	0	0	0	3.09 mA
		0	0	0	1	9.18 mA
		0	0	1	0	15.24 mA
				...		
		0	1	0	0	27.39 mA
				...		
		1	0	0	0	51.69 mA
				...		
		1	1	1	94.20 mA	
D7,D6, D5,D4	RSVD	Reserved				

7. Pin Descriptions: Si7013 (Top View)

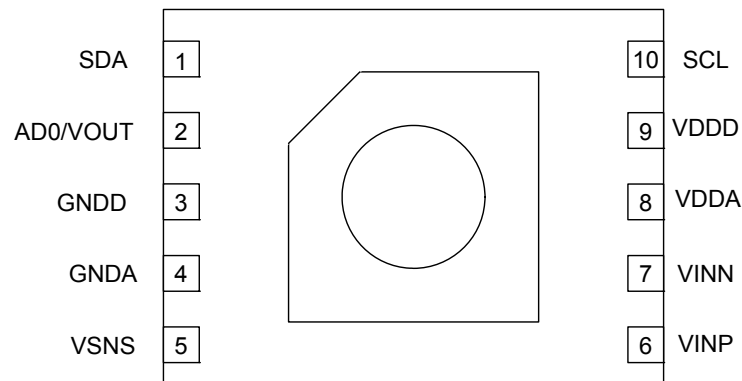

Pin Name	Pin #	Pin Description
SDA	1	I ² C data.
AD0/VOUT	2	Dual function pin. This pin can be switched high or low and is generally used to drive an external thermistor interface. On powerup, this pin acts as a device address select pin. Tie high or low to set device address LSB. See Figure 5 and Figure 6.
GNDD	3	Digital ground. This pin is connected to ground on the circuit board.
GNDA	4	Analog ground. This pin is connected to ground on the circuit board.
VSNS	5	Voltage Sense Input. Tie to VDD.*
VINP	6	Analog to digital converter positive input.
VINN	7	Analog to digital converter negative input.
VDDA	8	Analog power. This pin is connected to power on the circuit board.
VDDD	9	Digital power. This pin is connected to power on the circuit board.
SCL	10	I ² C clock
T _{GND}	Paddle	This pad is connected to GND internally. This pad is the main thermal input to the on-chip temperature sensor. The paddle should be soldered to a floating pad.

***Note:** VSNS must be high at power up or device will be held in reset.

Si7013-A10

8. Ordering Guide

Table 21. Device Ordering Guide

P/N	Description	Max. Accuracy		Pkg	Operating Range (°C)	Protective Cover	Packing Format
		Temp	RH				
Si7013-A10-GM	Digital temperature/ humidity sensor	±0.4 °C	± 3%	DFN 6	-40 to +85 °C	N	Tube
Si7013-A10-GMR	Digital temperature/ humidity sensor	±0.4 °C	± 3%	DFN 6	-40 to +85 °C	N	Tape & Reel
Si7013-A10-GM1	Digital temperature/ humidity sensor	±0.4 °C	± 3%	DFN 6	-40 to +85 °C	Y	Cut Tape
Si7013-A10-GM1R	Digital temperature/ humidity sensor	±0.4 °C	± 3%	DFN 6	-40 to +85 °C	Y	Tape & Reel
Si7013-A10-IM	Digital temperature/ humidity sensor— industrial temp range	±0.4 °C	± 3%	DFN 6	-40 to +125 °C	N	Tube
Si7013-A10-IMR	Digital temperature/ humidity sensor— industrial temp range	±0.4 °C	± 3%	DFN 6	-40 to +125 °C	N	Tape & Reel
Si7013-A10-IM1	Digital temperature/ humidity sensor— industrial temp range	±0.4 °C	± 3%	DFN 6	-40 to +125 °C	Y	Cut Tape
Si7013-A10-IM1R	Digital temperature/ humidity sensor— industrial temp range	±0.4 °C	± 3%	DFN 6	-40 to +125 °C	Y	Tape & Reel
Si7013-A10-YM0	Digital temperature/ humidity sensor— automotive	±0.4 °C	± 3%	DFN 6	-40 to +125 °C	N	Tube
Si7013-A10-YM0R	Digital temperature/ humidity sensor— automotive	±0.4 °C	± 3%	DFN 6	-40 to +125 °C	N	Tape & Reel
Si7013-A10-YM1	Digital temperature/ humidity sensor— automotive	±0.4 °C	± 3%	DFN 6	-40 to +125 °C	Y	Cut Tape
Si7013-A10-YM1R	Digital temperature/ humidity sensor— automotive	±0.4 °C	± 3%	DFN 6	-40 to +125 °C	Y	Tape & Reel

Note: The "A" denotes product revision A and "10" denotes firmware revision 1.0.

9. Package Outline

9.1. Package Outline: 3x3 10-pin DFN

Figure 11 illustrates the package details for the Si7013. Table 21 lists the values for the dimensions shown in the illustration.

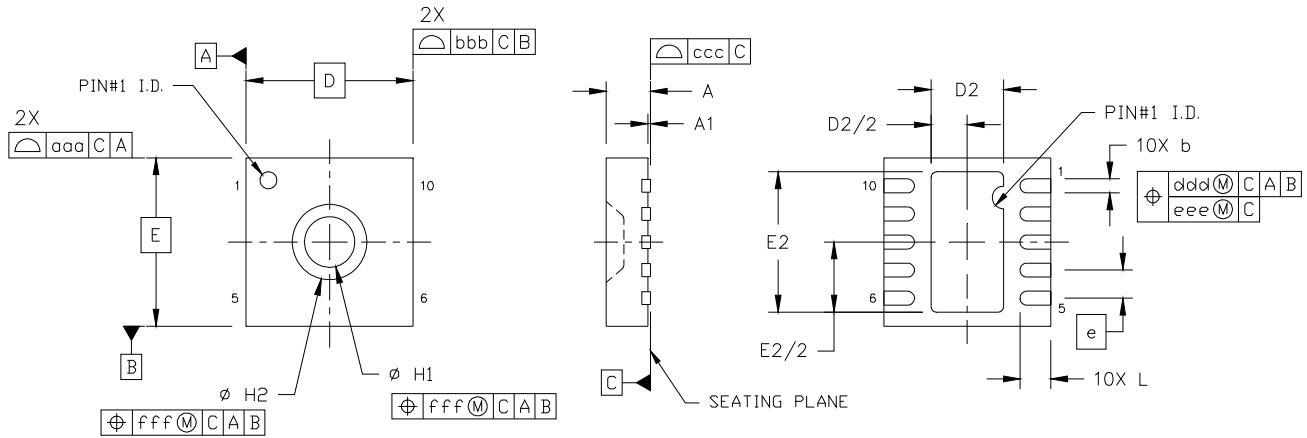

Figure 11. 10-pin DFN Package Drawing

Table 22. 10-Pin DFN Package Dimensions

Dimension	Min	Nom	Max
A	0.70	0.75	0.80
A1	0.00	0.02	0.05
b	0.18	0.25	0.30
D	3.00 BSC.		
D2	1.20	1.30	1.40
e	0.50 BSC.		
E	3.00 BSC.		
E2	2.40	2.50	2.60
H1	0.85	0.90	0.95
H2	1.39	1.44	1.49
L	0.50	0.55	0.60
aaa	0.10		
bbb	0.10		
ccc	0.05		
ddd	0.10		
eee	0.05		
fff	0.05		

Notes:

1. Dimensioning and Tolerancing per ANSI Y14.5M-1994.
2. Recommended card reflow profile is per the JEDEC/IPC J-STD-020 specification for Small Body Components.

Si7013-A10

9.2. Package Outline: 3x3 10-pin DFN with Protective Cover

Figure 12 illustrates the package details for the Si7013 with the optional protective cover. Table 22 lists the values for the dimensions shown in the illustration.

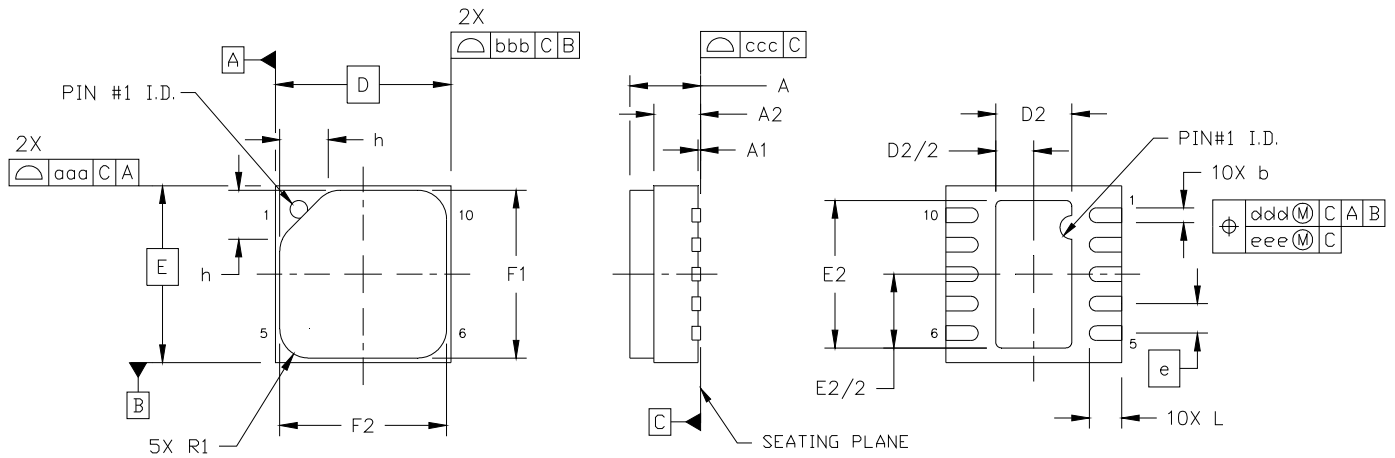

Figure 12. 10-pin DFN with Protective Cover

Table 23. 10-pin DFN with Protective Cover Diagram Dimensions

Dimension	Min	Nom	Max
A	—	—	1.21
A1	0.00	0.02	0.05
A2	0.70	0.75	0.80
b	0.18	0.25	0.30
D	3.00 BSC.		
D2	1.20	1.30	1.40
e	0.50 BSC.		
E	3.00 BSC.		
E2	2.40	2.50	2.60

Dimension	Min	Nom	Max
F1	2.80	2.85	2.90
F2	2.80	2.85	2.90
h	0.76	0.83	0.90
L	0.50	0.55	0.60
R1	0.45	0.50	0.55
aaa	0.10		
bbb	0.10		
ccc	0.05		
ddd	0.10		
eee	0.05		

Notes:

1. All dimensions shown are in millimeters (mm).
2. Dimensioning and Tolerancing per ANSI Y14.5M-1994.

10. PCB Land Pattern and Solder Mask Design

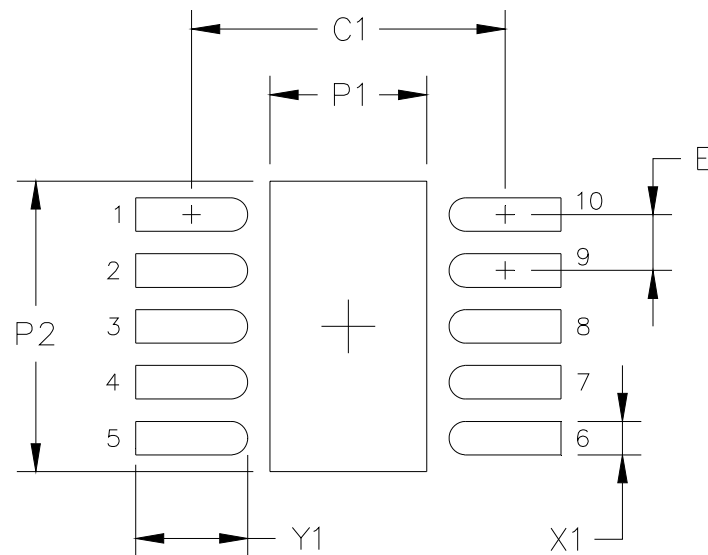

Table 24. PCB Land Pattern Dimensions

Symbol	mm
C1	2.80
E	0.50
P1	1.40
P2	2.60
X1	0.30
Y1	1.00

Notes:

General

- All dimensions shown are at Maximum Material Condition (MMC). Least Material Condition (LMC) is calculated based on a Fabrication Allowance of 0.05 mm.
- This Land Pattern Design is based on the IPC-7351 guidelines.

Solder Mask Design

- All metal pads are to be non-solder mask defined (NSMD). Clearance between the solder mask and the metal pad is to be 60 μm minimum, all the way around the pad.

Stencil Design

- A stainless steel, laser-cut and electro-polished stencil with trapezoidal walls should be used to assure good solder paste release.
- The stencil thickness should be 0.125 mm (5 mils).
- The ratio of stencil aperture to land pad size should be 1:1 for all perimeter pins.
- A 2x1 array of 0.95 mm square openings on 1.25 mm pitch should be used for the center ground pad to achieve a target solder coverage of 50%.

Card Assembly

- A No-Clean, Type-3 solder paste is recommended.
- The recommended card reflow profile is per the JEDEC/IPC J-STD-020 specification for Small Body Components.

Si7013-A10

11. Top Marking

11.1. Si7013 Top Marking

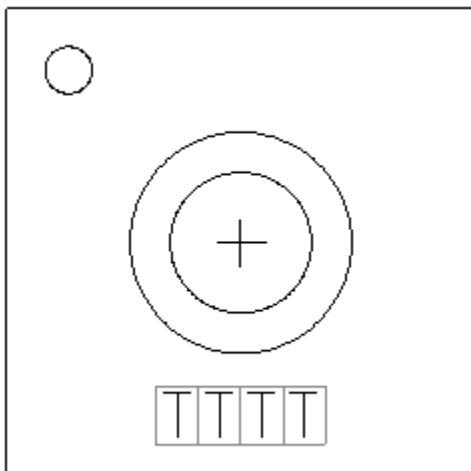

11.2. Top Marking Explanation

Mark Method:	Laser
Pin 1 Indicator:	Circle = 0.30 mm Diameter Upper-Left Corner
Font Size:	0.30 mm
Line 1 Marking:	TTTT = Mfg Code

12. Additional Reference Resources

- AN607: Si70xx Humidity Sensor Designer's Guide

DOCUMENT CHANGE LIST

Revision 0.1 to Revision 0.6

- Updates to Section 1. Electrical Specifications.
- Updated Table 2. General Specifications.
- Updated Figure 1. I2C Interface Timing Diagram.
- Updated Table 6. Voltage Converter Specifications.
- Updated Table 7. Thermal Characteristics.
- Updated Section 2. Typical Applications Circuits.
- Updated Figure 5. Typical Application Circuit for Thermistor Interface with AD0 = 1.
- Updated Table 15. I2C Command Table.
- Updated Section 4.4 PCB Assembly.
- Updated Section 5.3 Measuring Relative Humidity.
- Updated Section 5.4 Measuring Temperature.
- Updated Section 5.6 Nonlinear Correction of Voltage Inputs.
- Updated Section 5.7 Heater.
- Removed Section 5.8 Device Identification and added device identification information to Section 5.9.
- Updated Section 6. Control Registers.
- Updated Section 9. Package Outline.
- Updated Section 11. Top Marking.

Revision 0.6 to Revision 0.95

- Updated Table 1. Recommended Operating Conditions
- Updated Table 2. General Specifications
- Updated Table 3. I2C Interface Specifications
- Updated Table 4 Humidity Sensor
- Updated Table 5. Temperature Sensor
- Updated Table 8. Absolute Maximum Ratings
- Updated Figure 5. Typical Application Circuit for Thermistor Interface with AD0 = 1
- Updated Figure 6. Typical Application Circuit for Thermistor Interface with AD0 = 0
- Updated Figure 8. Si7013 Block Diagram
- Updated Section 4.1. Relative Humidity Sensor Accuracy
- Updated Section 4.4.1. Soldering
- Updated Table 15. Analog Input Ranges
- Updated Section 5.1. Issuing a Measurement Command
- Updated Section 5.2. Reading and Writing User Registers
- Updated Section 5.4. Nonlinear Correction of Voltage Inputs

- Added Section 5.5. Firmware Revision
- Updated Section 6. Control Registers
- Updated Table 21. Device Ordering Guide

Revision 0.95 to Revision 1.0

- Updated Table 2. General Specifications
- Updated footnotes in Table 4. Humidity Sensor
- Updated Table 6. Voltage Converter Specifications
- Added ESD Tolerance to Table 8. Absolute Maximum Ratings
- Updated part numbers in Table 9. Typical Application Circuit BOM for Relative Humidity and Temperature Measurement, Table 10. Typical Application Circuit BOM for Thermistor Interface, and Table 11. Typical Application Circuit BOM for Single-Ended 0 to 3 V Measurement
- Updated Section 5.1. Issuing a Measurement Command
- Updated Section 5.1.2. Measuring Temperature
- Updated Section 5.4.2. Entering Lookup Table Values into OTP Memory
- Updated Section 5.5. Firmware Revision
- User Register 2, bits 4, 5 and 6
- Updated Table 20. Register Summary
- Updated part numbers in Table 21. Device Ordering Guide

CONTACT INFORMATION

Silicon Laboratories Inc.

400 West Cesar Chavez
Austin, TX 78701
Tel: 1+(512) 416-8500
Fax: 1+(512) 416-9669
Toll Free: 1+(877) 444-3032

Please visit the Silicon Labs Technical Support web page:
<https://www.silabs.com/support/pages/contacttechnicalsupport.aspx>
and register to submit a technical support request.

Patent Notice

Silicon Labs invests in research and development to help our customers differentiate in the market with innovative low-power, small size, analog-intensive mixed-signal solutions. Silicon Labs' extensive patent portfolio is a testament to our unique approach and world-class engineering team.

The information in this document is believed to be accurate in all respects at the time of publication but is subject to change without notice. Silicon Laboratories assumes no responsibility for errors and omissions, and disclaims responsibility for any consequences resulting from the use of information included herein. Additionally, Silicon Laboratories assumes no responsibility for the functioning of undescribed features or parameters. Silicon Laboratories reserves the right to make changes without further notice. Silicon Laboratories makes no warranty, representation or guarantee regarding the suitability of its products for any particular purpose, nor does Silicon Laboratories assume any liability arising out of the application or use of any product or circuit, and specifically disclaims any and all liability, including without limitation consequential or incidental damages. Silicon Laboratories products are not designed, intended, or authorized for use in applications intended to support or sustain life, or for any other application in which the failure of the Silicon Laboratories product could create a situation where personal injury or death may occur. Should Buyer purchase or use Silicon Laboratories products for any such unintended or unauthorized application, Buyer shall indemnify and hold Silicon Laboratories harmless against all claims and damages.

Silicon Laboratories and Silicon Labs are trademarks of Silicon Laboratories Inc.
Other products or brandnames mentioned herein are trademarks or registered trademarks of their respective holders.

Компания «Life Electronics» занимается поставками электронных компонентов импортного и отечественного производства от производителей и со складов крупных дистрибьюторов Европы, Америки и Азии.

С конца 2013 года компания активно расширяет линейку поставок компонентов по направлению коаксиальный кабель, кварцевые генераторы и конденсаторы (керамические, пленочные, электролитические), за счёт заключения дистрибьюторских договоров

Мы предлагаем:

- Конкурентоспособные цены и скидки постоянным клиентам.
- Специальные условия для постоянных клиентов.
- Подбор аналогов.
- Поставку компонентов в любых объемах, удовлетворяющих вашим потребностям.
- Приемлемые сроки поставки, возможна ускоренная поставка.
- Доставку товара в любую точку России и стран СНГ.
- Комплексную поставку.
- Работу по проектам и поставку образцов.
- Формирование склада под заказчика.
- Сертификаты соответствия на поставляемую продукцию (по желанию клиента).
- Тестирование поставляемой продукции.
- Поставку компонентов, требующих военную и космическую приемку.
- Входной контроль качества.
- Наличие сертификата ISO.

В составе нашей компании организован Конструкторский отдел, призванный помогать разработчикам, и инженерам.

Конструкторский отдел помогает осуществить:

- Регистрацию проекта у производителя компонентов.
- Техническую поддержку проекта.
- Защиту от снятия компонента с производства.
- Оценку стоимости проекта по компонентам.
- Изготовление тестовой платы монтаж и пусконаладочные работы.



Тел: +7 (812) 336 43 04 (многоканальный)

Email: org@lifeelectronics.ru